

# Assembly Instructions

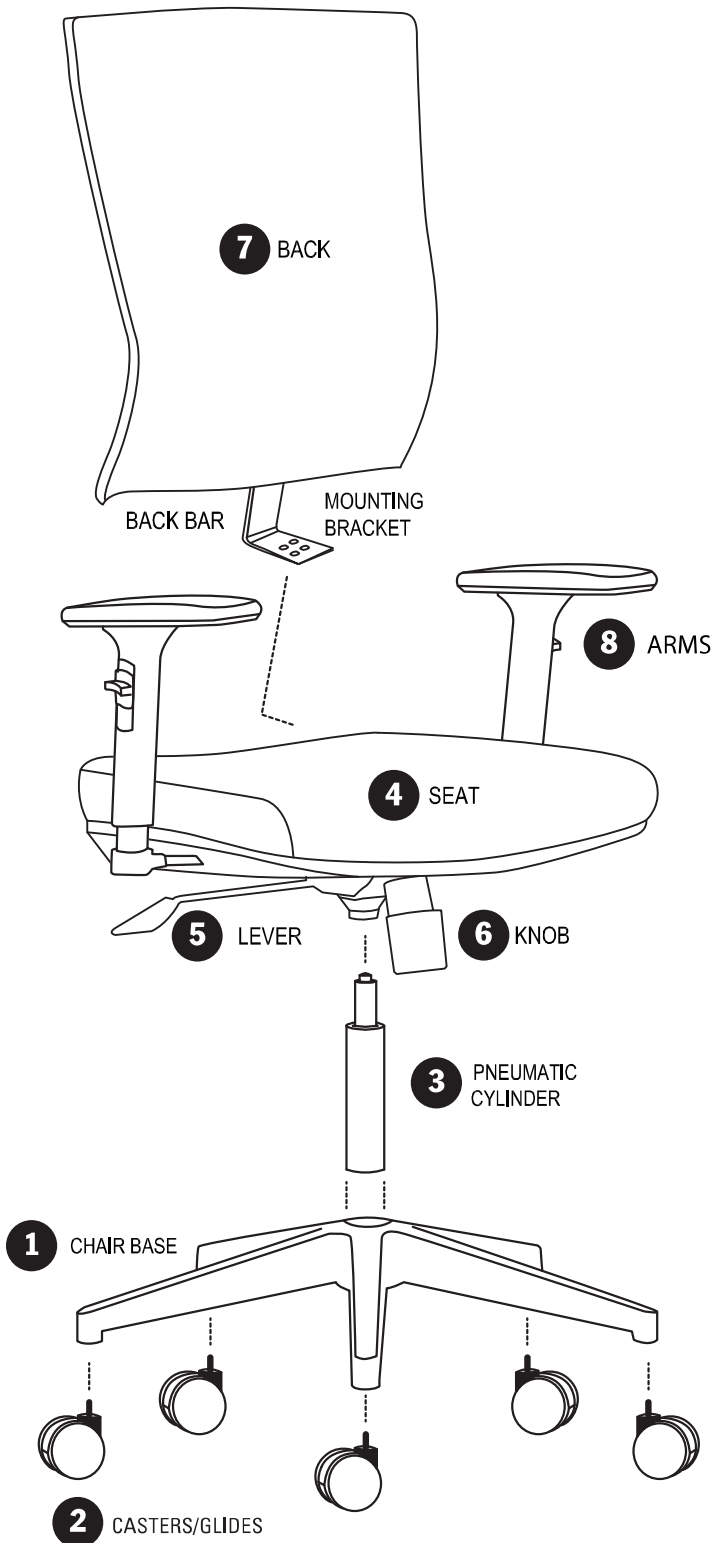

- 1) Remove base, back, pneumatic cylinder, casters/glides, and seat from box.
- 2) Insert casters/glides **2** on base **1**. Using pressure, push the casters/glides into the base making sure they are all the way in.
- 3) Place base **1** with legs on hard level surface.
- 4) Insert cylinder **3** into center hole of base and lightly push down.
- 5) (Optional) Arm rests **8** are factory installed for shipping. Use enclosed allen wrench to adjust width of arms: loosen screw, adjust arms, tighten screw.
- 6) Turn seat upside down and place on the edge of a table to slide the back bar into position.
- 7) Attach back bar to seat **4** using 4 bolts and 4 washers. Firmly tighten with enclosed allen wrench.
- 8) Turn assembled seat over and align the center hole on the bottom of the seat with the top of the pneumatic cylinder and lightly push down. With the weight of your body, carefully sit on the seat. This will press the base, pneumatic cylinder, and seat together.