

---

**METAL TABLE  
TABLE EN MÉTAL  
MESA DE METAL**



---

**We are here to help!**  
**Before you return it - contact us.**

**Nous sommes là pour vous aider!**  
**Avant de retourner le produit, veuillez communiquer avec nous.**



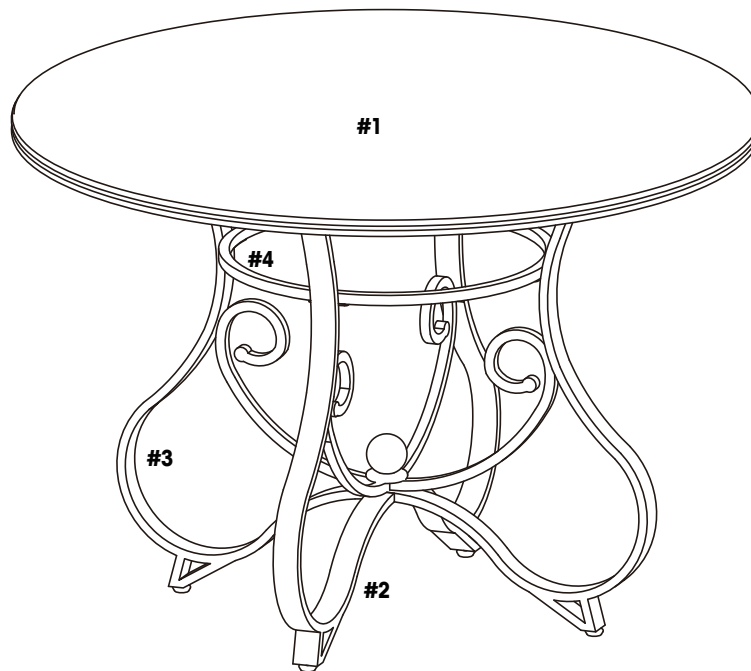

**¡Estamos aquí para ayudarle!**  
**Antes de regresar el producto, comuníquese con nosotros.**

## PART LIST



<b>#1</b>	<b>TABLE TOP</b>	<b>01</b>
<b>#2</b>	<b>UPPER LEG FRAME</b>	<b>01</b>
<b>#3</b>	<b>LOWER LEG FRAME</b>	<b>01</b>
<b>#4</b>	<b>SUPPORT RING</b>	<b>01</b>



## HARDWARE LIST

<b>A</b>	<b>BOLT (Ø1/4"X5/8")</b>		<b>16</b>
<b>B</b>	<b>CAP</b>		<b>01</b>
<b>C</b>	<b>FLAT WASHER</b>		<b>17</b>
<b>D</b>	<b>SPRING WASHER</b>		<b>17</b>
<b>E</b>	<b>NUT</b>		<b>01</b>

## TOOLS REQUIRED

<b>ALLEN KEY</b>		<b>SUPPLIED</b>
<b>OPEN SPANNER</b>		<b>SUPPLIED</b>

### IMPORTANT:

1. Do not tighten bolts completely until all bolts are completely lined up and inserted into holes / nuts.
2. Do not over tighten screws and bolts to avoid stripping.
3. Please use hand tools to assemble this product. Do not use power tools.

1.

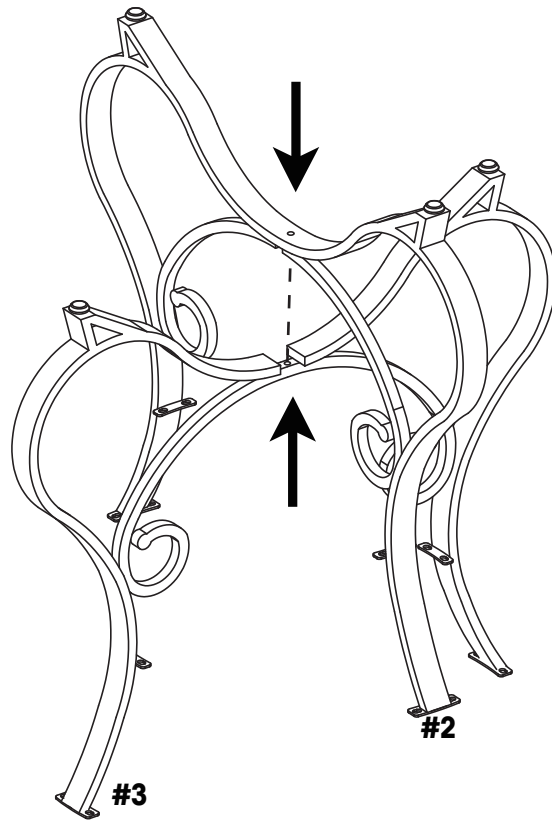



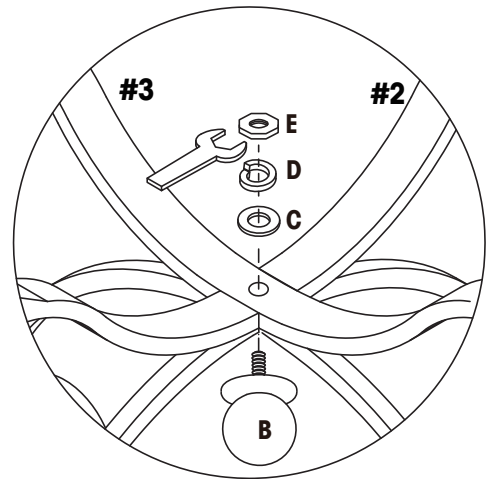
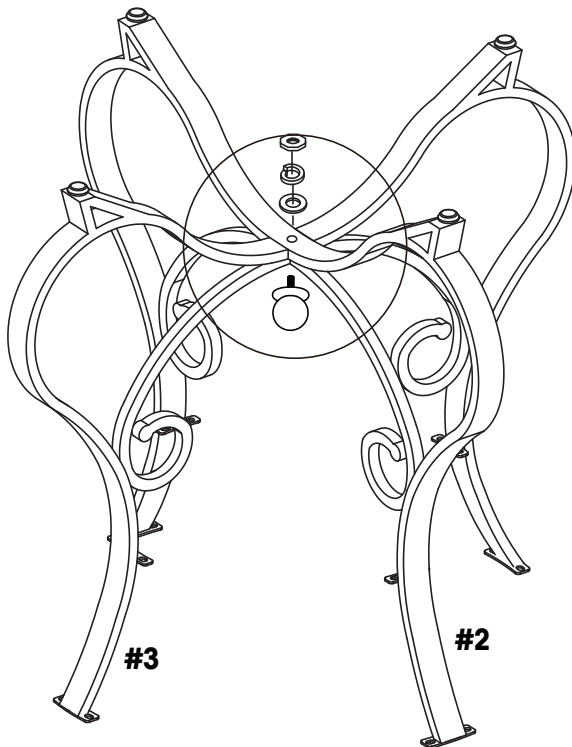

2.

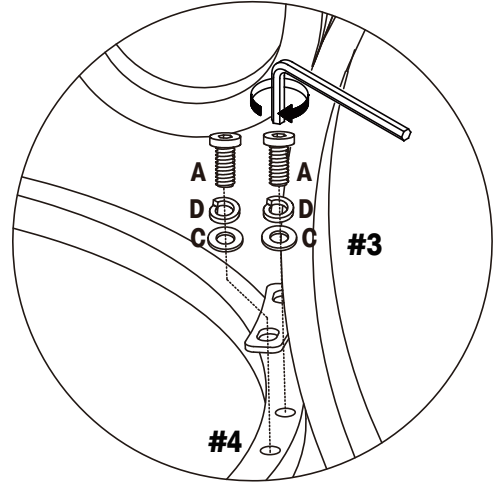
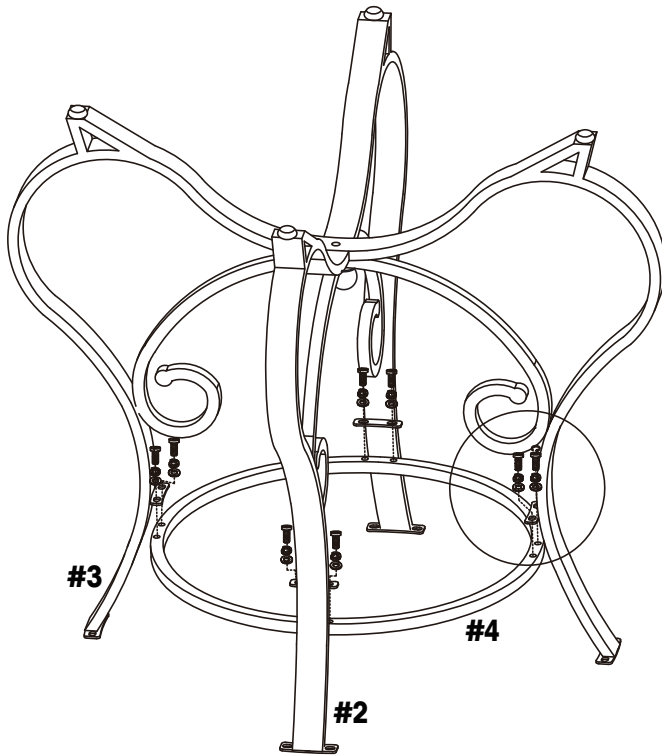

B		01
C		01
D		01
E		01

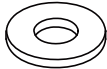

3.

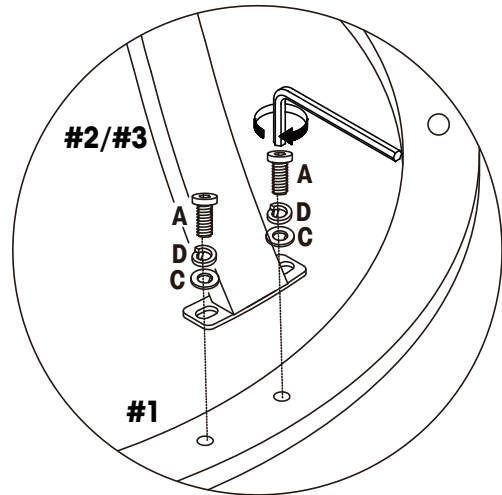
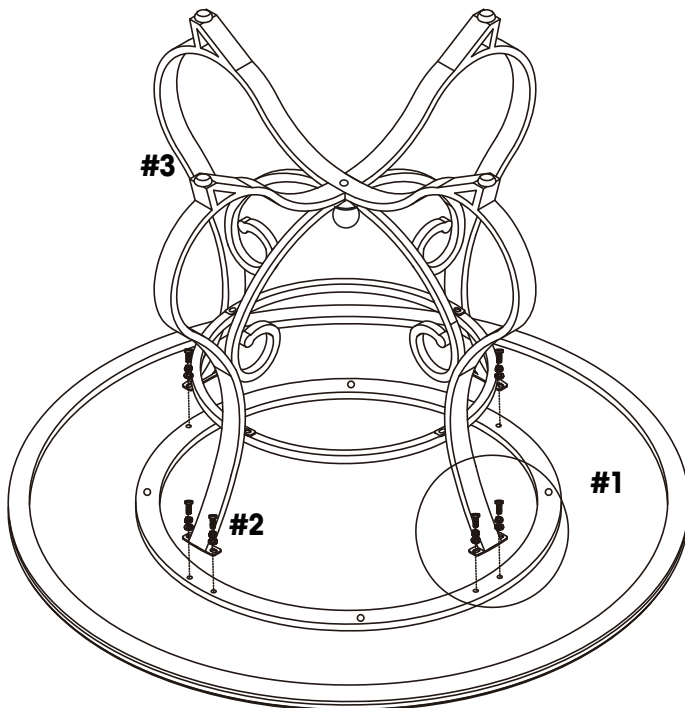

A		08
C		08
D		08

4.



A		08
C		08
D		08

---

**WARRANTY**  
**GARANTIE**  
**GARANTÍA**

MADE IN CHINA  
FABRIQUÉ EN CHINE  
HECHO EN CHINA

