

Wicker Sofa set

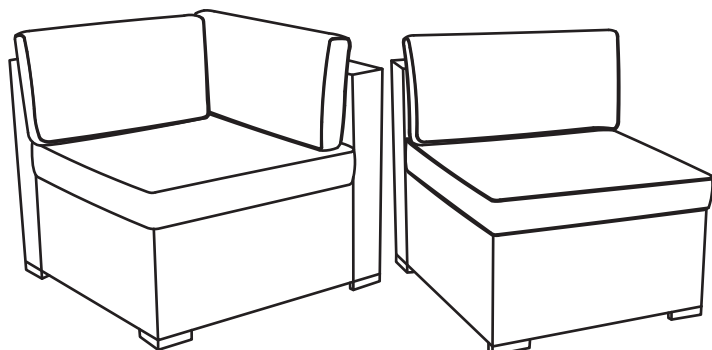



**IMPORTANT, RETAIN FOR
FUTURE REFERENCE:
READ CAREFULLY.**

Safety

- For domestic use only.
- Always use on firm level ground.
- Don't tighten all the bolts before the product is fully assembled.
- It would be useful to ask someone to help you assemble the product.
- Periodic structural checks of this product should be undertaken, do not use if you have any doubts about its fitness for purpose.
- Do not stand on the seat.
- Do not sit on the armrest.
- Do not let children play with this product.
- Maximum load per seat: 250 lbs.

At the beginning of the season

- Check to ensure that all components and fixings of this product are secure, do not use if you have any doubts about its fitness for purpose.

At the end of the season







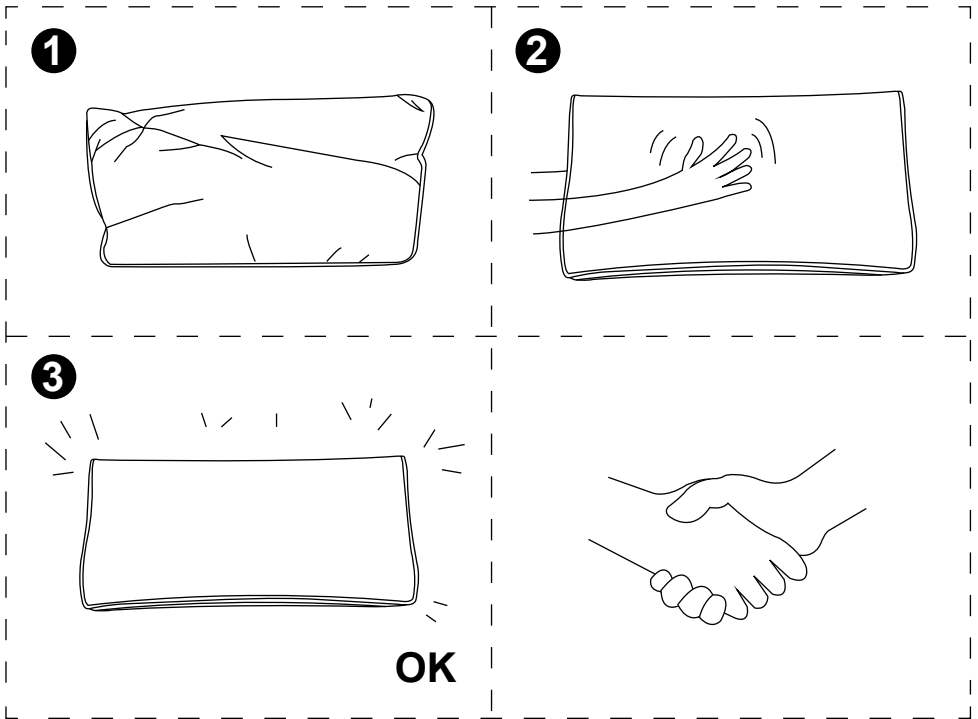

- This product should be stored under cover during prolonged spells of adverse weather (wet or cold) and also during the winter (ideally in a garden shed or garage).
- Always clean and dry thoroughly before storage.

Tips for Cushions

In order to compress the package, we put the cushions in the gap of some parts. So there may be crinkle on the fabric. Don't worry. Just flap every corner of the cushion evenly and it will get back into its original shape soon.

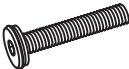
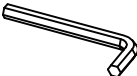

COMPONENT LIST - CORNER SOFA

Item no.	Reference Image	Description	Qty.
A		Corner Panel	1
B		Corner Panel	1
C		Seat Base	1
F		Washer	9
K		M6X35 Head Cap Screws	9
L		Allen Key	1
S		Seat Cushion	1
T		Back Cushion	1
T1		Short Cushion	1

NOTE:

When tightening the Screws, tighten sequentially.

DO NOT tighten any Screws fully and then move on to the next one.

This may cause the frame to warp.

If there is still wobbles or screw holes cannot be aligned, loosen the bolts and execute this same process.

If the Sofa is not stable it could lead to damage to the product.

- 1** Attach the corner panel (A) to the corner panel (B) with M6*35 Head Cap Screws (K) and Washers (F). Do this in 2 places.

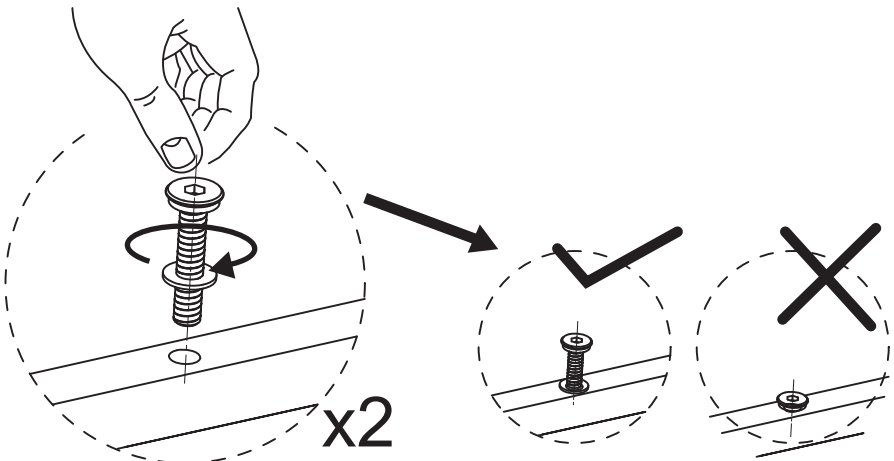
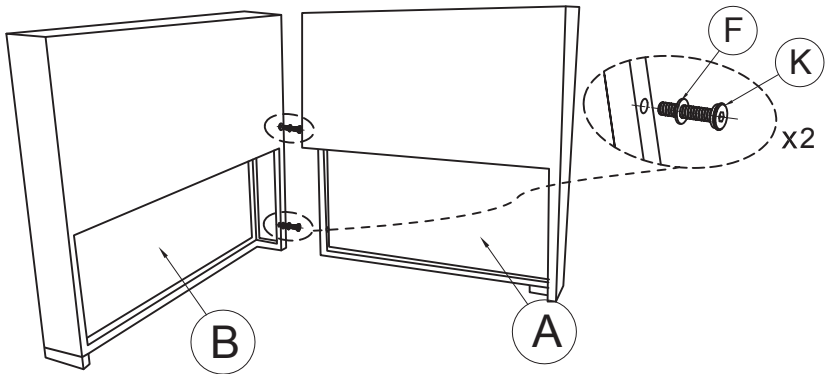

NOTE: DO NOT TIGHTEN THE SCREWS COMPLETELY.

2

Attach the seat base (C) to the corner panel (A) and corner panel (B) with M6*35 Head Cap Screws (K) and Washers (F). Do this in 7 places.

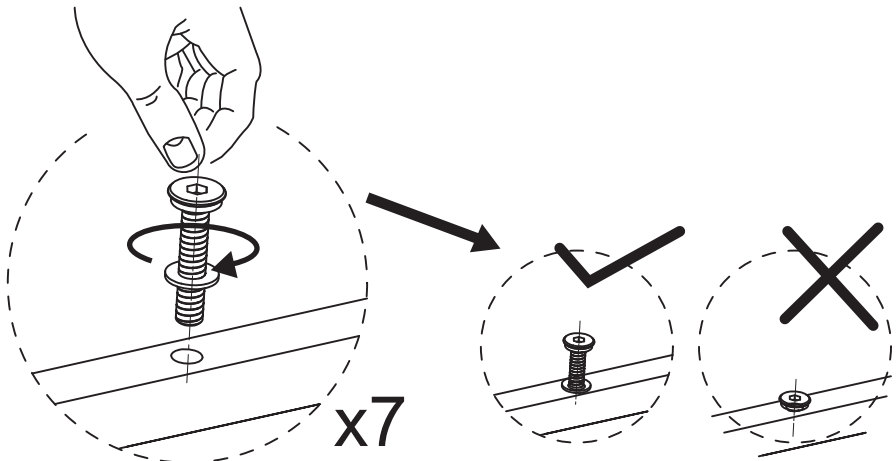
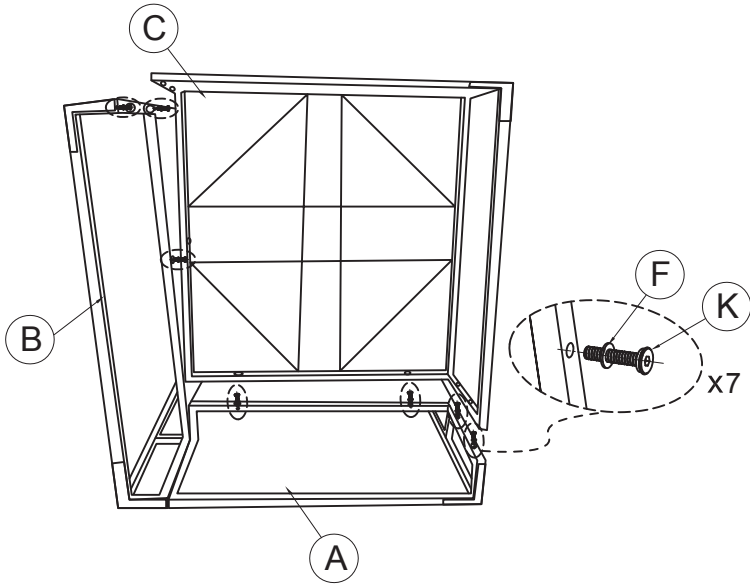

NOTE: DO NOT TIGHTEN THE SCREWS COMPLETELY.

- 3** Tighten all 9 Screws into place with Allen Key (L).

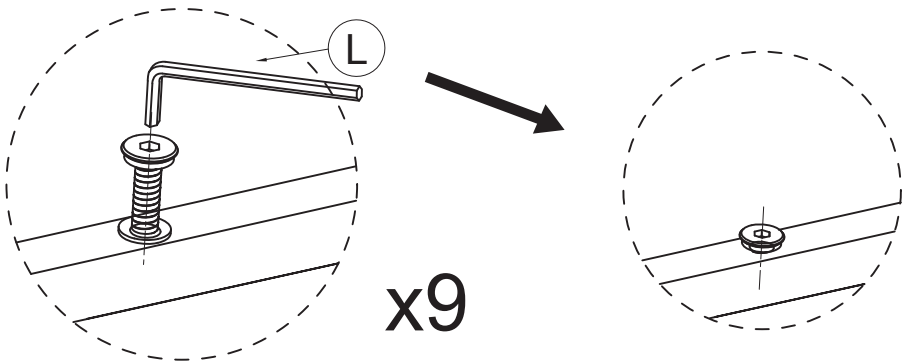
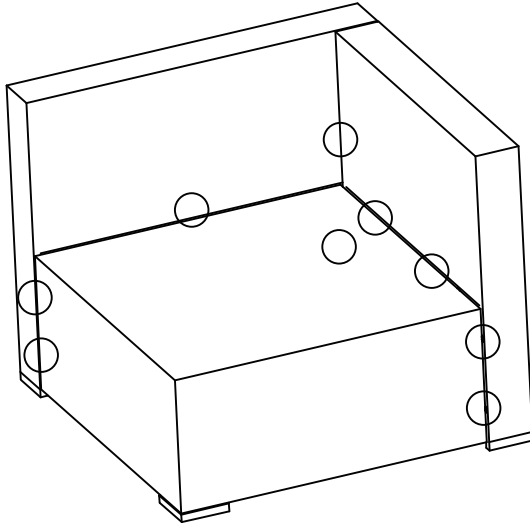



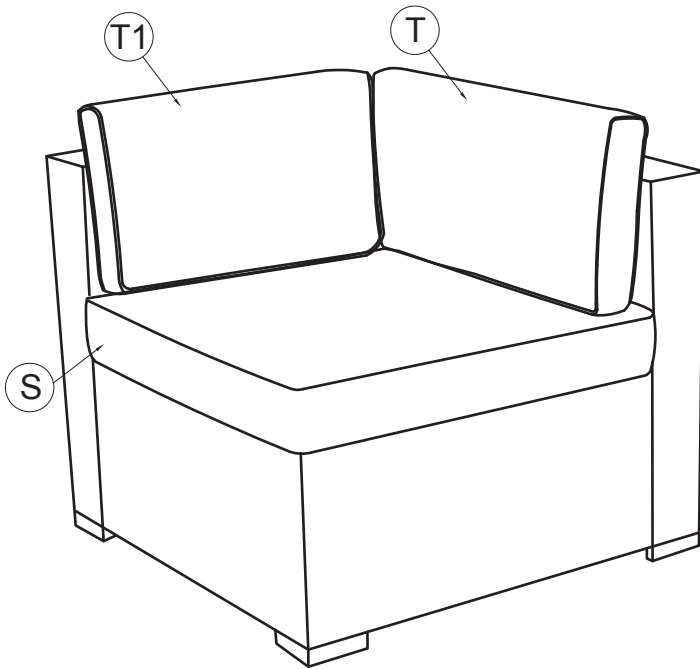

NOTE:IF ANY SCREW HOLES CANNOT BE ALIGNED,
LOOSEN ALL THE SCREWS AND GO BACK STEP
1 AND RESTART ASSEMBLY.

4

Place the Sofa on a level surface. Place the Seat Cushion (S) and Back Cushion (T) and Short Cushion (T1) on the Sofa. Your Sofa is ready for use.

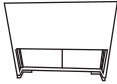
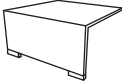

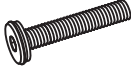
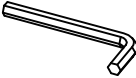
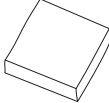
COMPONENT LIST - ARMLESS SOFA

Item no.	Reference Image	Description	Qty.
D		Seat Back	1
E		Seat Base	1
G		Side Panel	1
F		Washer	8
K		M6X35 Head Cap Screws	8
L		Allen Key	1
S		Seat Cushion	1
T		Back Cushion	1

NOTE:

When tightening the Screws, tighten sequentially.
 DO NOT tighten any Screws fully and then move on to the next one.
 This may cause the frame to warp.
 If there is still wobbles or screw holes cannot be aligned, loosen the bolts and execute this same process.
 If the Sofa is not stable it could lead to damage to the product.

- 1** Attach the seat back (D) to the seat base (E) with M6*35 Head Cap Screws (K) and Washers (F). Do this in 4 places.

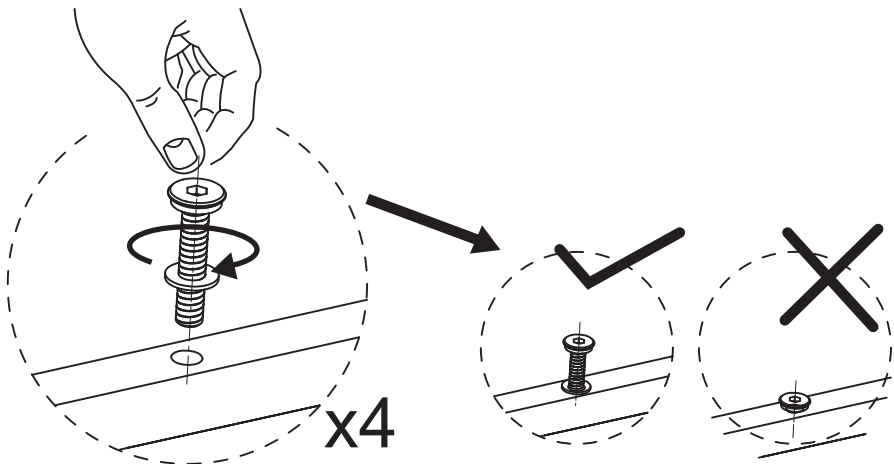
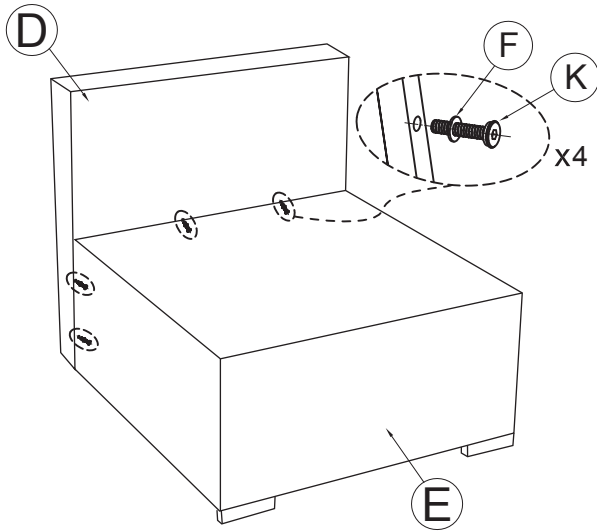

NOTE: DO NOT TIGHTEN THE SCREWS COMPLETELY.

2

Attach the side panel (G) to the seat back (D) and seat base (E) with M6*35 Head Cap Screws (K) and Washers (F). Do this in 4 places.

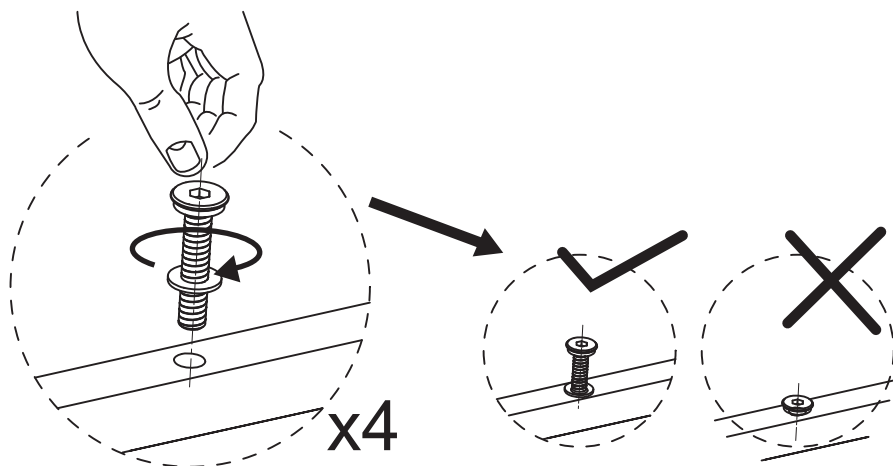
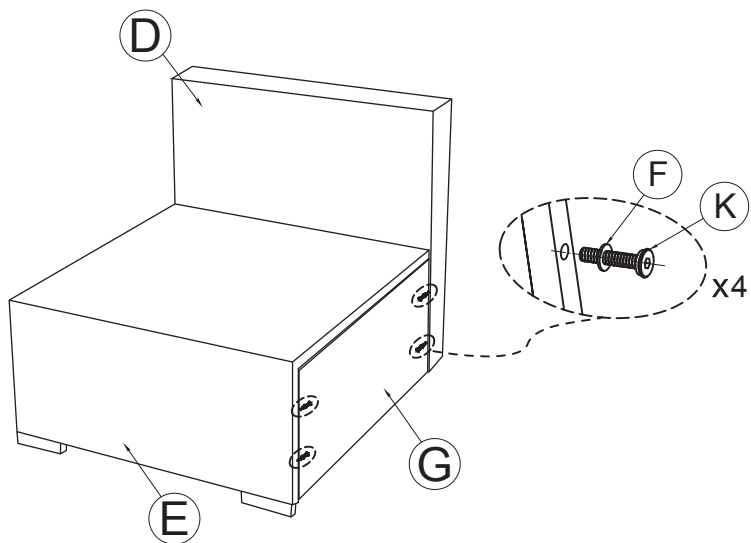

NOTE: DO NOT TIGHTEN THE SCREWS COMPLETELY.

3 Tighten all 8 Screws into place with Allen Key (L).

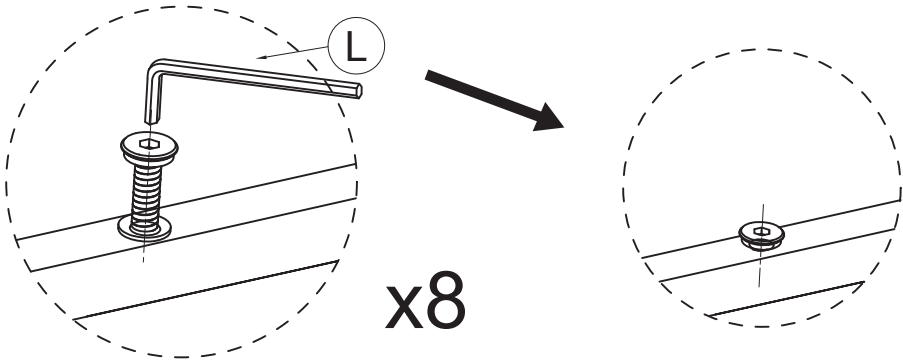
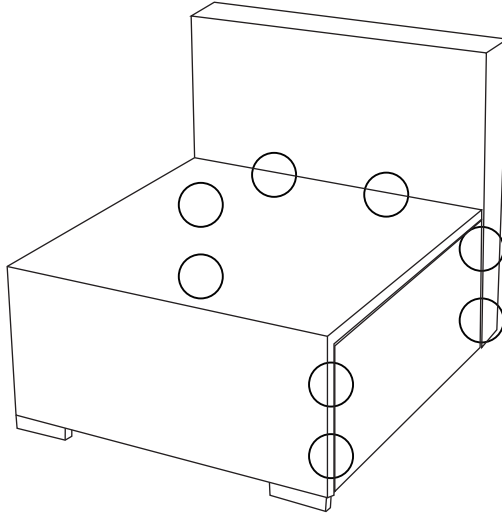

x8

NOTE:IF ANY SCREW HOLES CANNOT BE ALIGNED,
LOOSEN ALL THE SCREWS AND GO BACK STEP
1 AND RESTART ASSEMBLY.

- 4 Place the Sofa on a level surface. Place the Seat Cushion (S) and Back Cushion (T) on the Sofa. Your Sofa is ready for use.

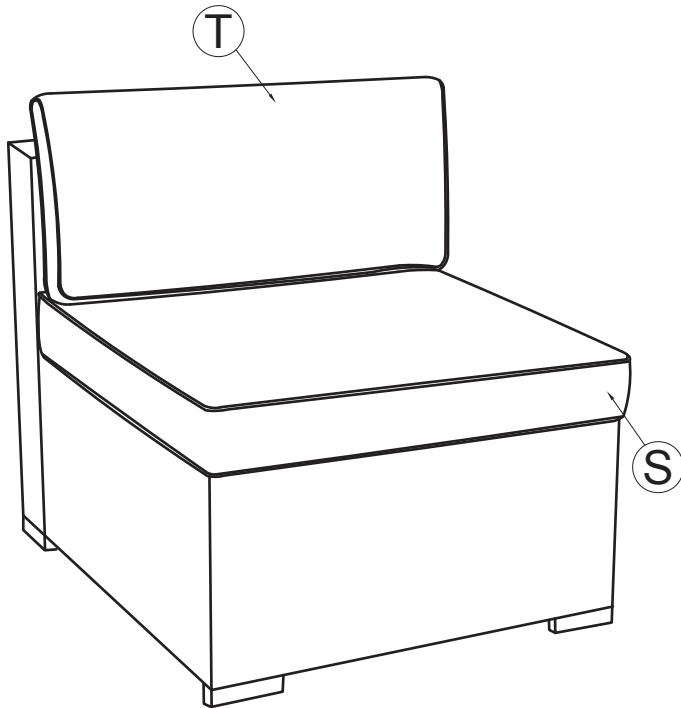

SECTIONAL SOFA CONNECTOR MANUAL

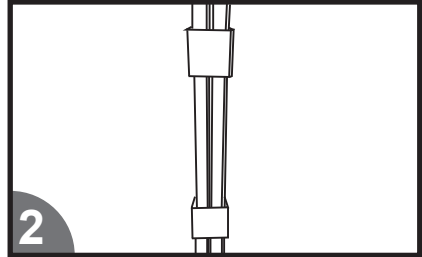
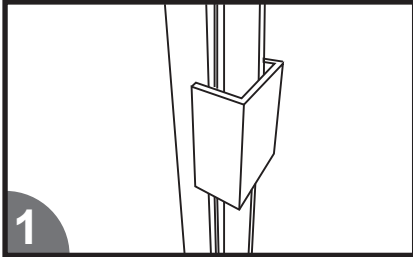

-
- Sectional outdoor wicker patio sofa is very light weight in nature and subject to movement.
 - These high quality fasteners prevents movement between modules to maintain the aesthetically good look of your modular patio furniture set.
 - Two fasteners are recommended between Two adjoining module.