

ASSEMBLY PART

1.

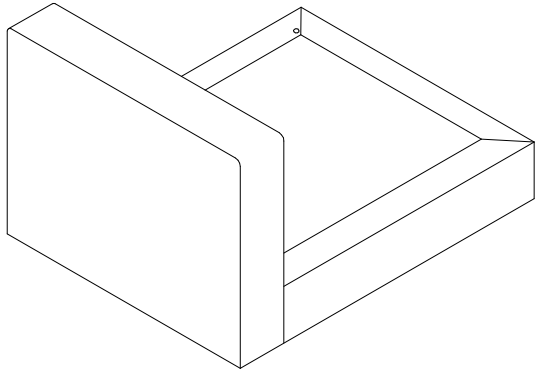

LEFT SIDE (1PC)

2.

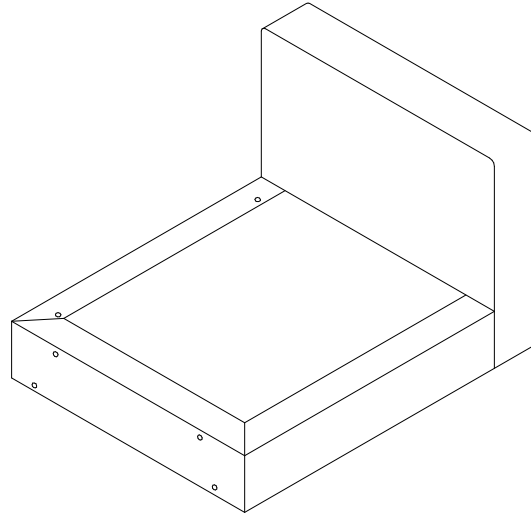

RIGHT SIDE (1PC)

3.

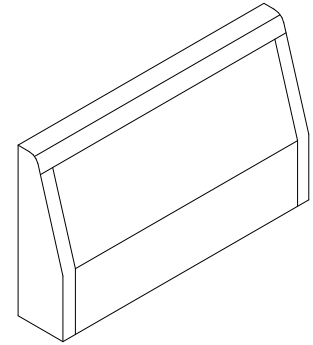

BACK REST (2PCS)

4.

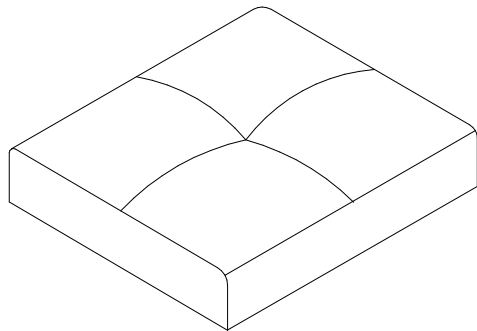

SEAT CUSHION (2PCS)

5.

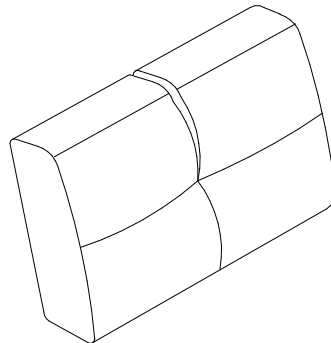

BACK PILLOWS INSIDE FILLING
(2PCS)

6.

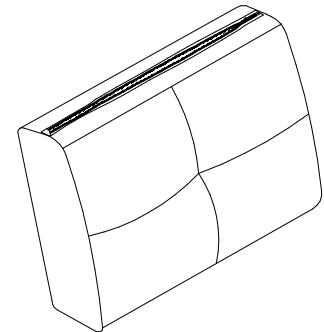

PILLOW CASE COVERS (2PCS)

8.

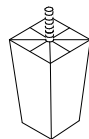

LEG (4PCS)

9.

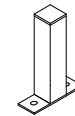

CENTER LEG (2PCS)

HARDWARE LIST

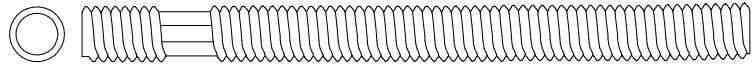

A

4PCS

5/16 x 80mm

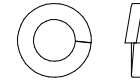

B

12PCS

Spring Washer 5/16

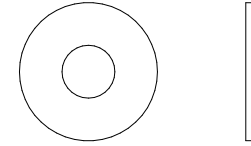

C

12PCS

Flat Washer 5/16 x 22mm

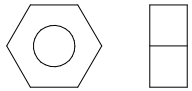

D

8PCS

Hex Nut 5/16 x 12mm

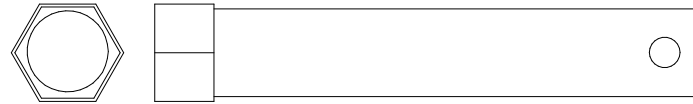

E

1PC

T Spanner

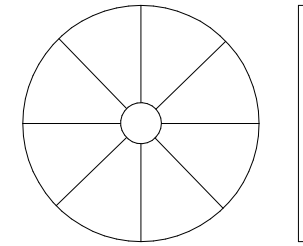

F

4PCS

Plastic Washer



G

1PC

Allen Key M4



H

1PC

Allen Key M5

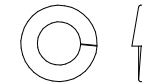

I

4PCS

Spring Washer 1/4

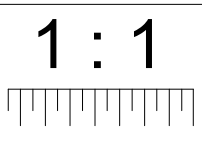

HARDWARE LIST

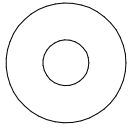

J

4PCS

Flat Washer 1/4 x 16mm

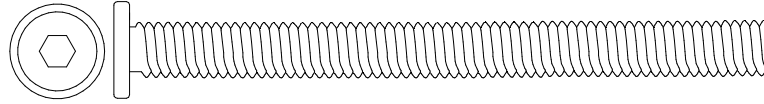

K

4PCS

JCBB Bolt 5/16 X 80mm

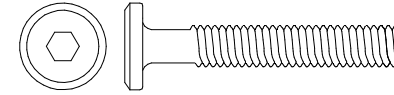

L

4PCS

JCBC Bolt 1/4 X 40mm

1 : 1



ASSEMBLY INSTRUCTION

STEP 1.

Open the cover cloth located behind the Left Side (1) and remove all parts and hardware.

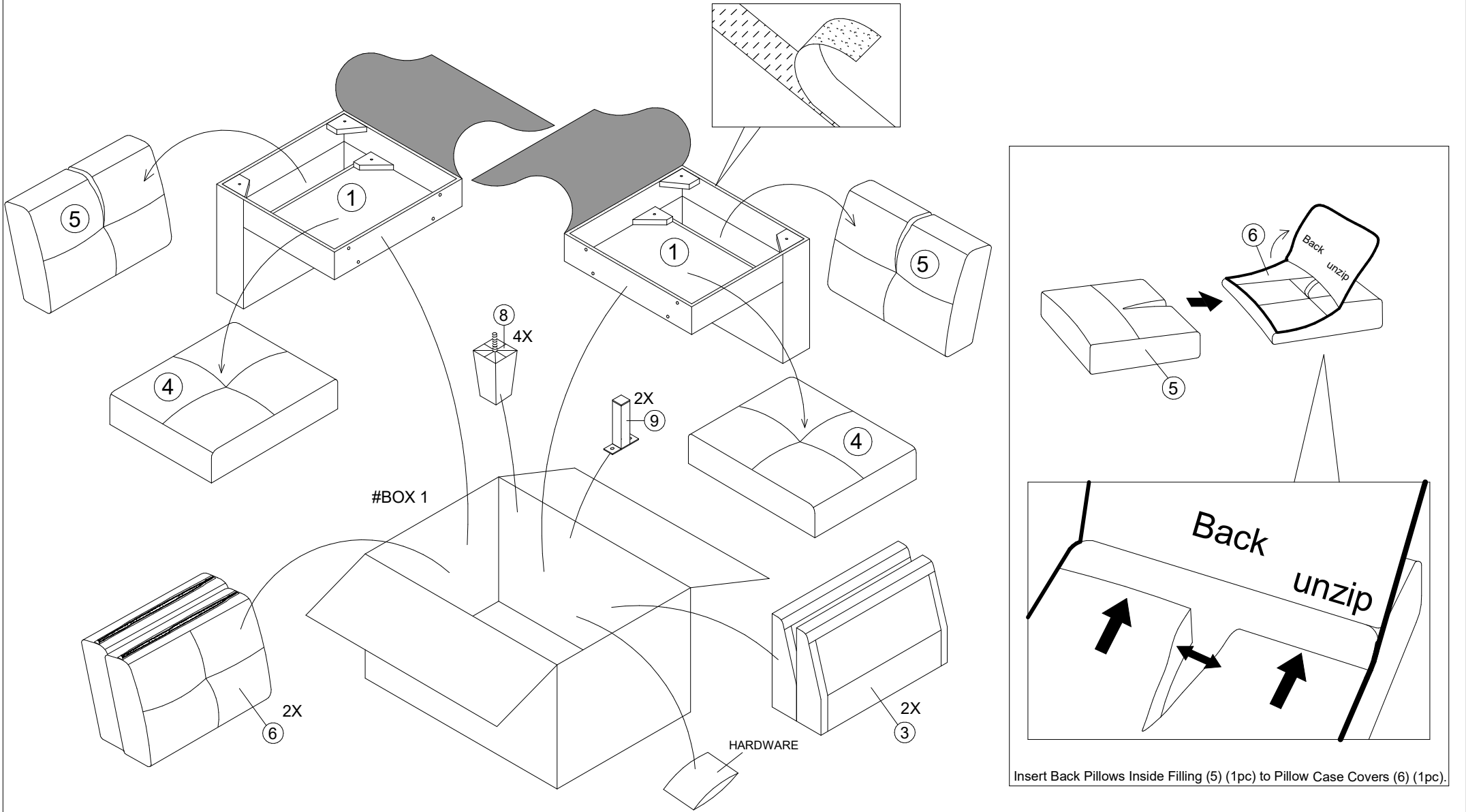

ASSEMBLY INSTRUCTION

STEP 2.

Attach 5/16 x 80mm (A) (4pcs) to Back Rest (3) (2pcs).

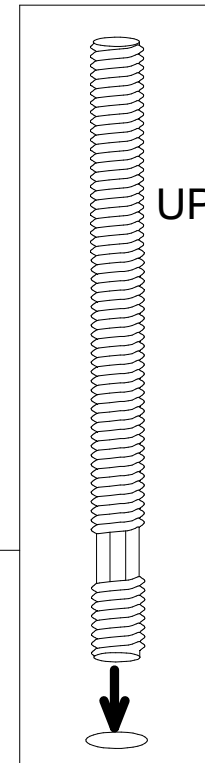
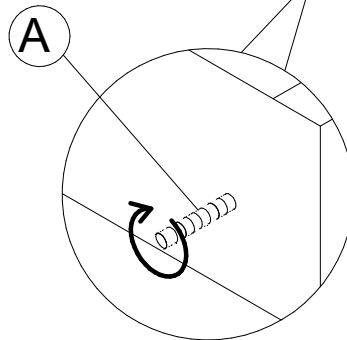
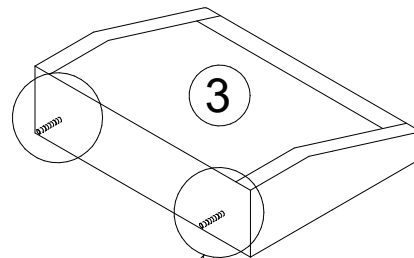
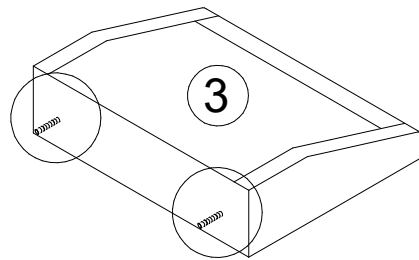
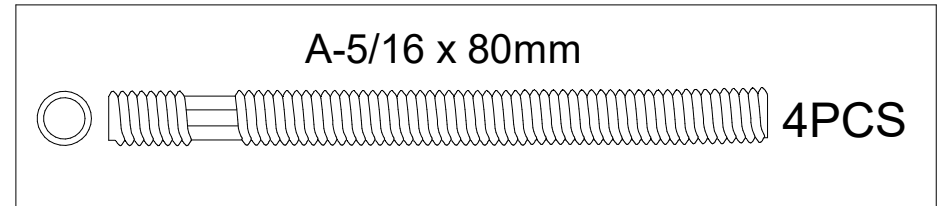

ASSEMBLY INSTRUCTION

STEP 3.

Attach the Back Rest (3) to Left Side (1) and to Right Side (2). Use Spring Washer 5/16 (B) (4pcs), Flat Washer 5/16 x 22mm (C) (4pcs), Hex Nut 5/16 x 12mm (D) (4pcs) and T Spanner (E) to fix.

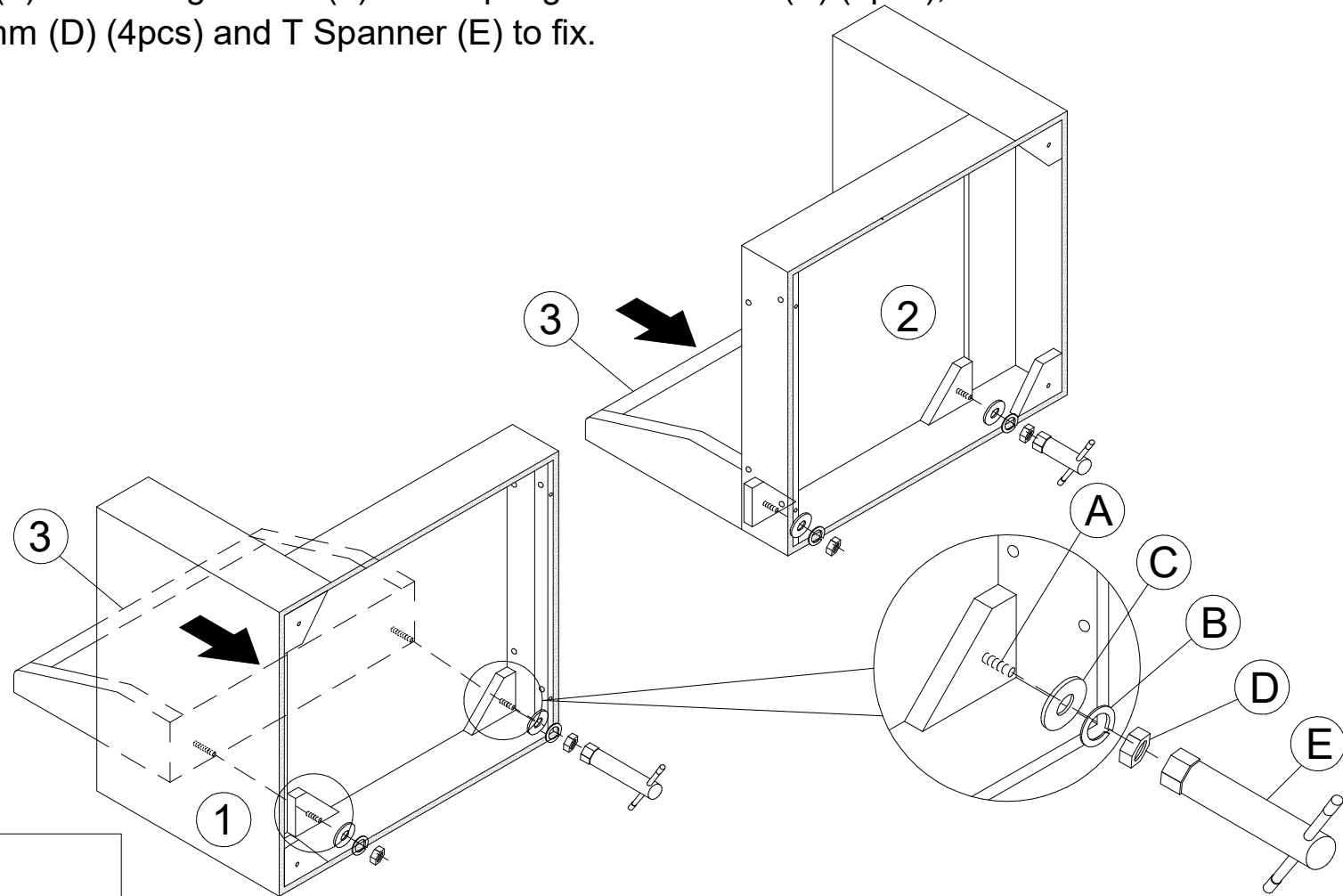
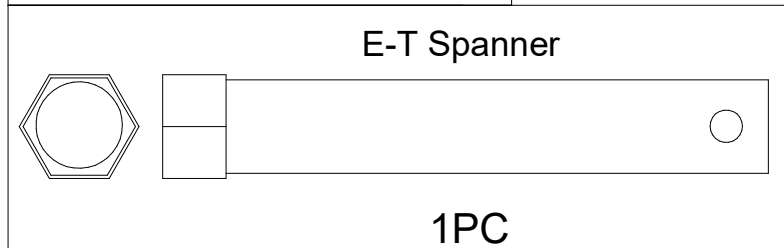
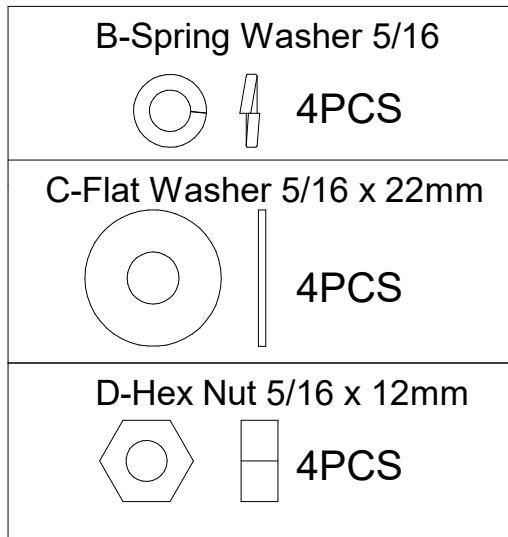

ASSEMBLY INSTRUCTION

STEP 4.

Attach Left Side (1) to Right Side (2). Use JCBB Bolt 5/16 x 80mm (K) (4pcs), Spring Washer 5/16 (B) (8pcs), Flat Washer 5/16 x 22mm (C) (8pcs), Hex Nut 5/16 x 12mm (D) (4pcs), T Spanner (E) and Allen Key M5 (H) to fix.

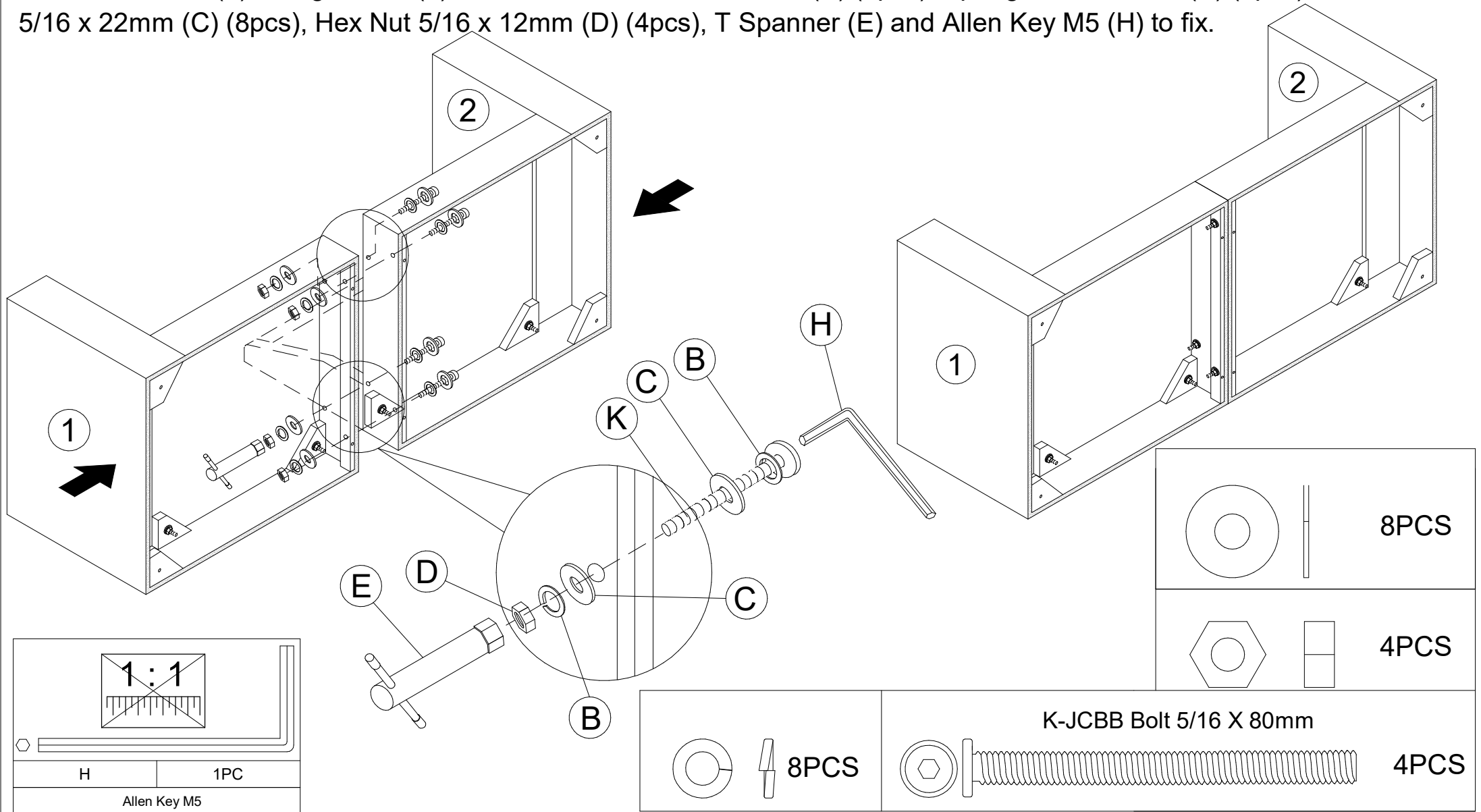

ASSEMBLY INSTRUCTION

STEP 5.

Take a Cover Cloth and closed with velcro. Attach Center Legs (9) (2pcs) to the center of the unit. Legs are to be attached using JCBC Bolt 1/4 x 40mm (L) (4pcs), Spring Washer 1/4 (I) (4pcs), Flat Washer 1/4 x 16mm (J) (4pcs) and Allen Key (G) to fix. Attach Legs (8) (4pcs) and Plastic Washer (F) (4pcs) to the four corners of the unit.

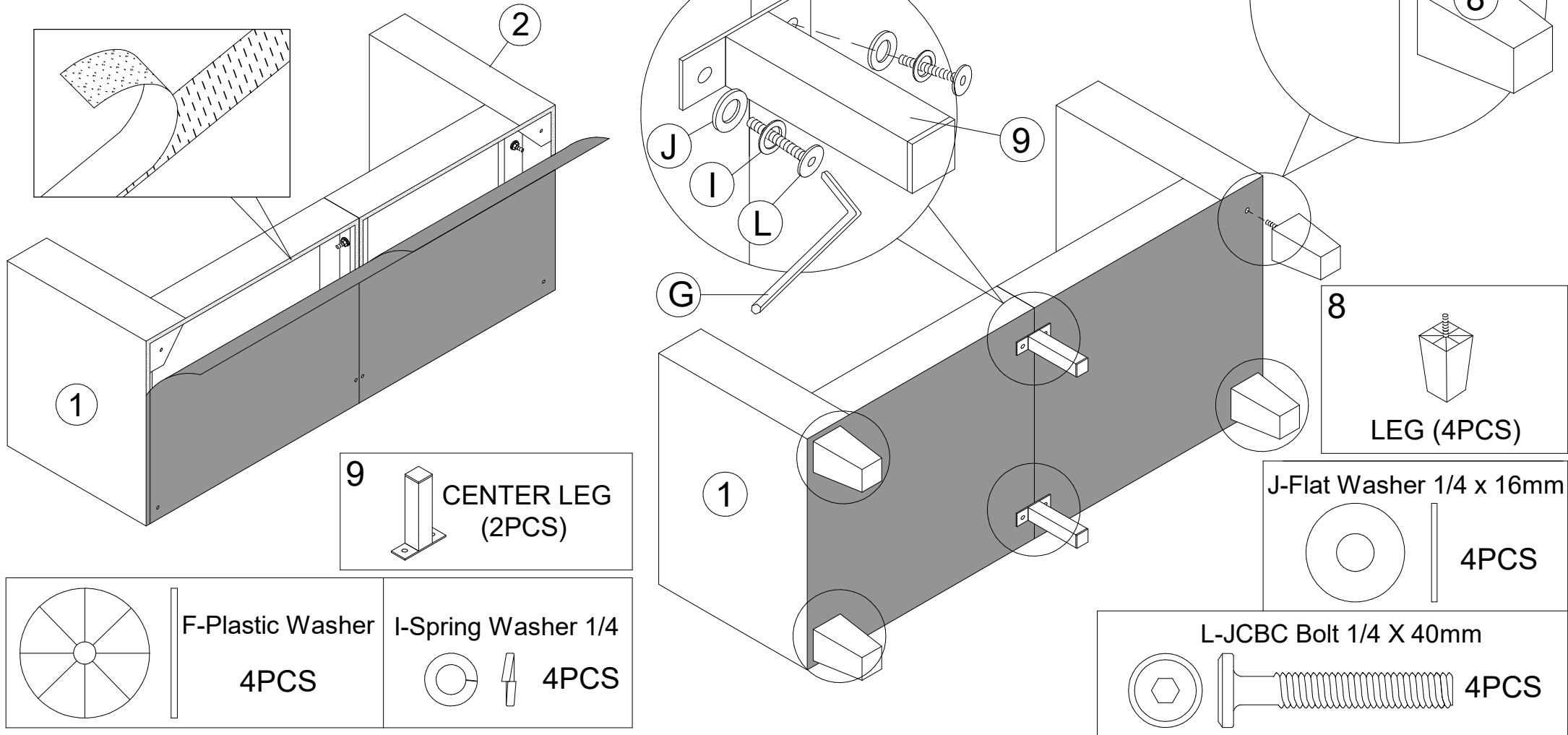

ASSEMBLY INSTRUCTION

STEP 6.

Attach the Seat Cushion (4) (2pcs).

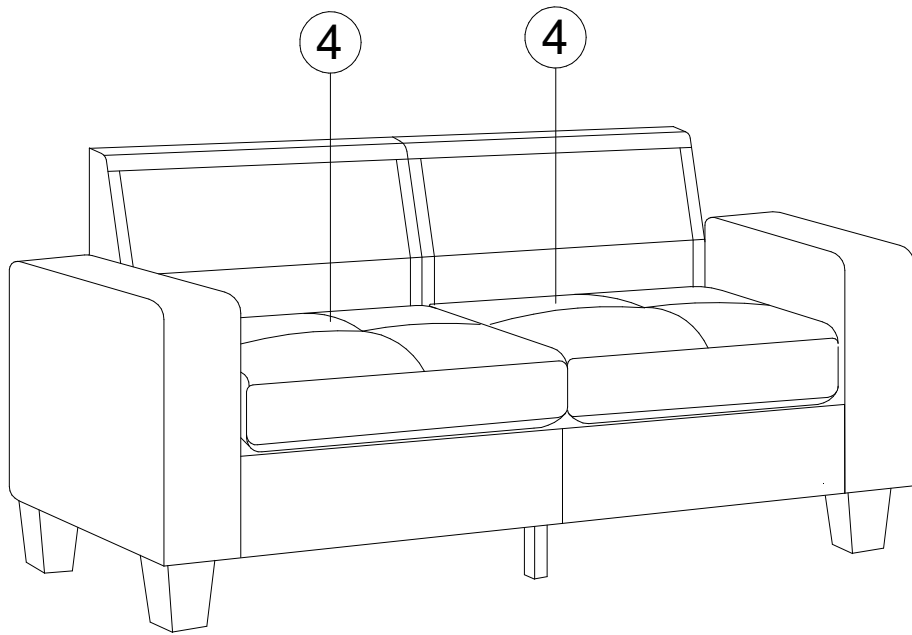

STEP 7.

Lay Back Pillow (5) (2pcs).

