

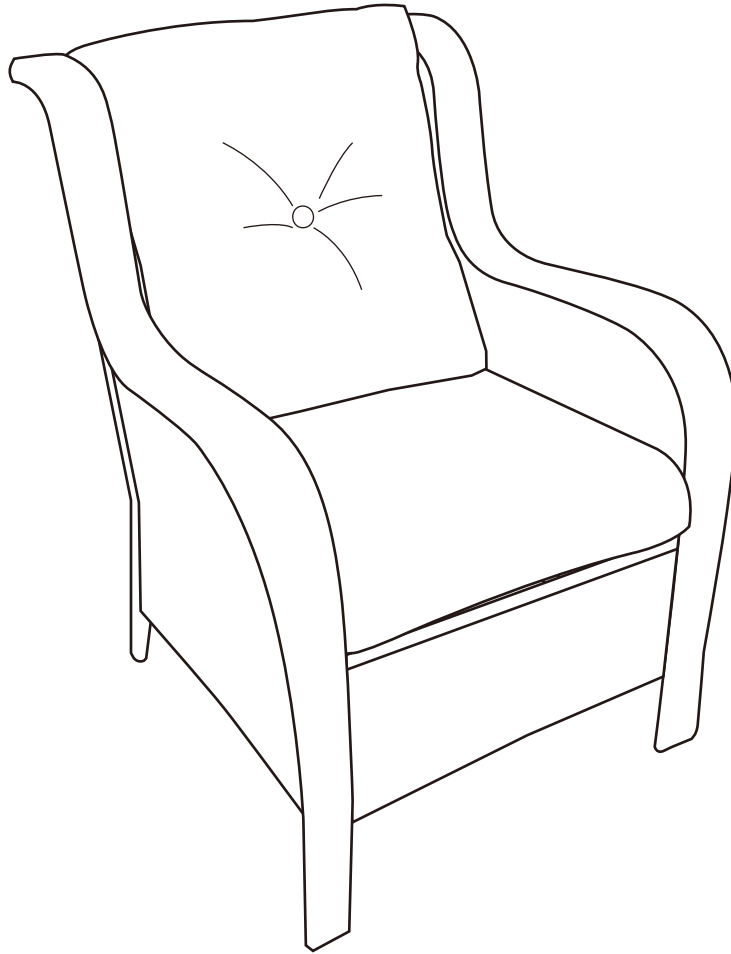

▶ SCAN ME









Assembly
Video

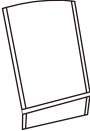
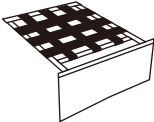

For any missing or damaging parts, hardware, or any other problems, WELCOME to email us at:
SERVICE@RILYSON.COM

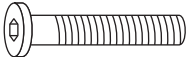
* Don't fully tighten all the bolts till the very end!

	PART LIST	DESCRIPTION	QTY
A1		LEFT ARM	1
A2		RIGHT ARM	1
B		BACK	1
C		SEAT	1
D		WASHER -- M6	10
E		BOLT -- M6 x 20mm	4
F		BOLT -- M6 x 35mm	6
G		HEX WRENCH	1

PRE-ASSEMBLY PREPARATION:

- Please read through the instructions before beginning assembly.
- Clear out the space for assembly and lay out all of the parts based on the Parts List, extra room will allow you to easily determine if all the pieces are present.
- Keep small parts and pieces away from children until fully assembled.

Step 1: Guide build-in nuts on back panel (B) into the holes on left arm (A1) and right arm (A2). Attach left arm (A1) and right arm (A2) to back panel (B) with 4pcs bolts (E) and 4pcs washers (D).

* Do not fully tighten bolts until the entire frame is assembled.

* Notice the position of left arm (A1) and right arm (A2), swapped arms would cause assembly failure. (Side wall of arm should be towards inside)

Step 2: Place seat panel (C) between arms and back panel, attach it to arms (A1 and A2) with 4pcs bolts (F) and 4pcs washers (D), and then attached to back panel with 2pcs bolts (F) and 2pcs washers (D).

Verify the alignment and adjust, now fully tighten all the bolts using hex wrench (G). Put seat cushion and back pillows on.

* Due to design and weaving handicraft limitation, it may has around 1/2 in. gap between arms and back panel after assembly. It is normal and will not affect outlooking and daily usage.

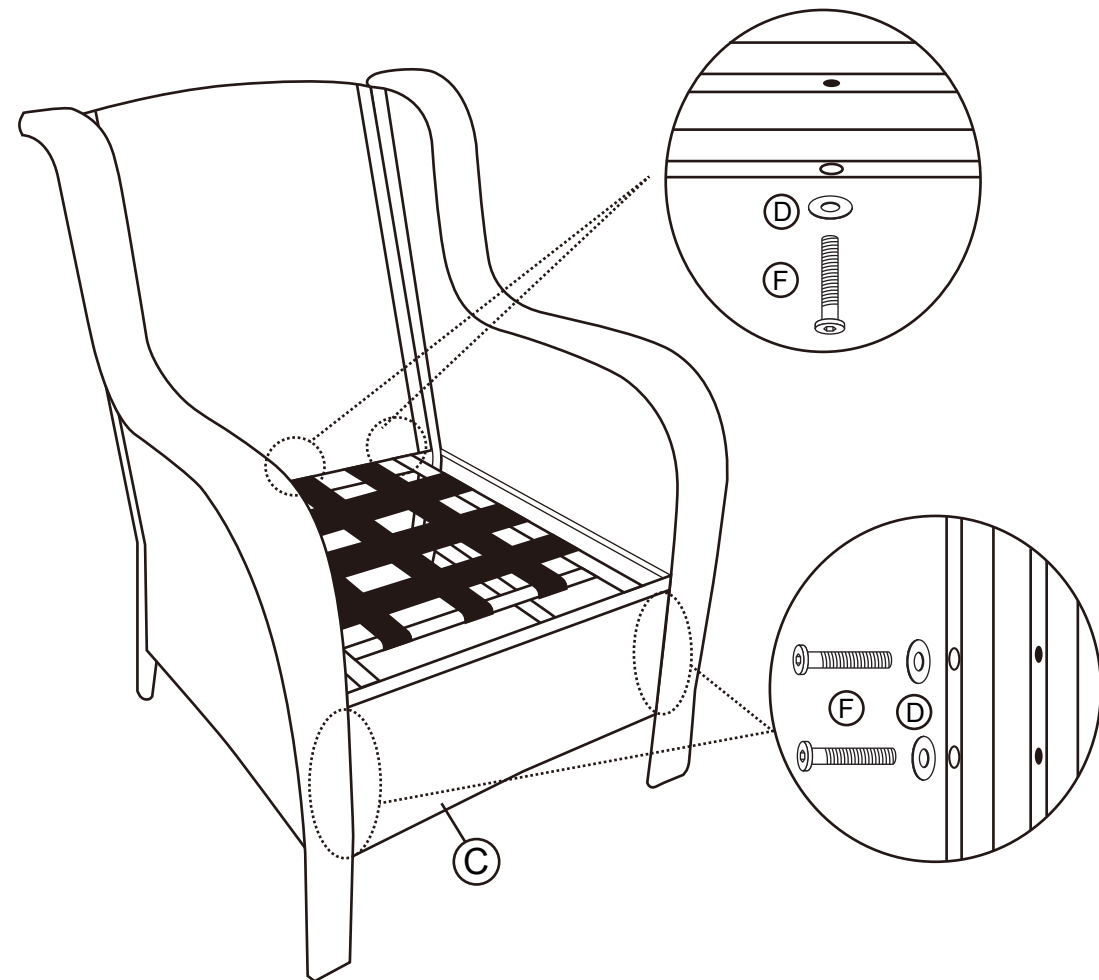
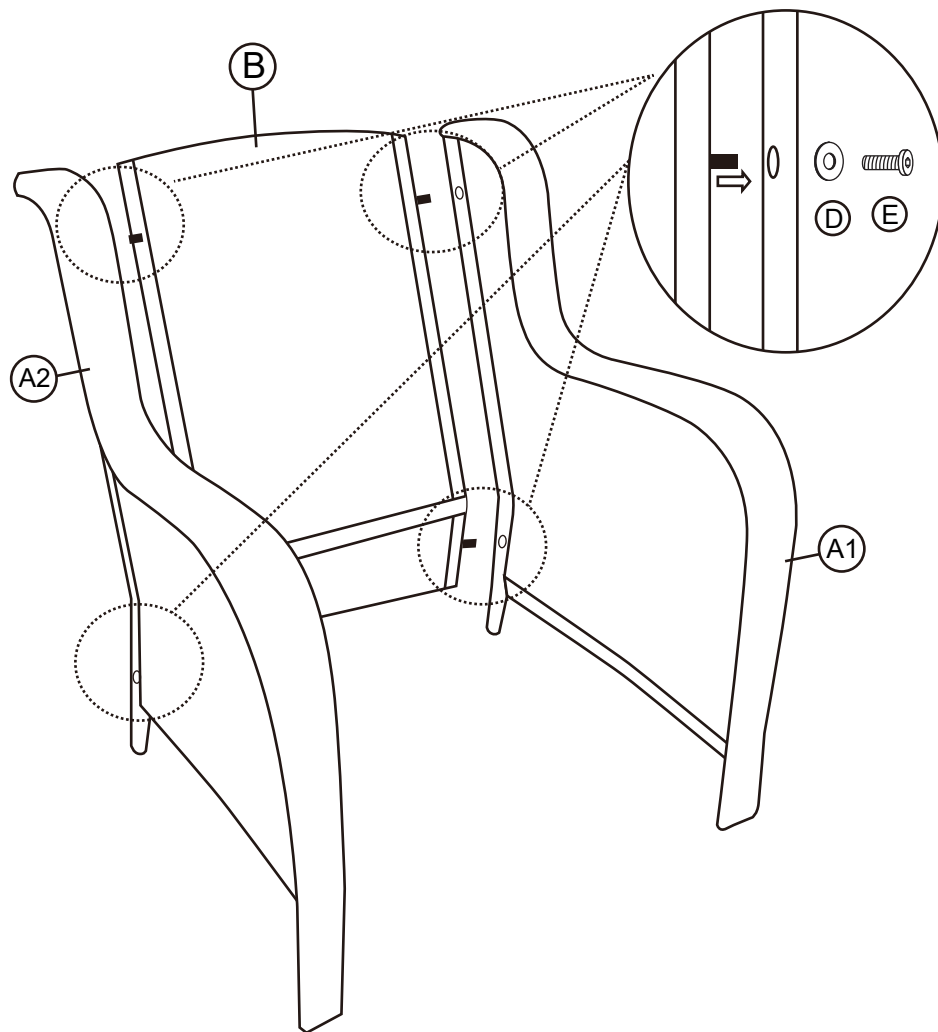



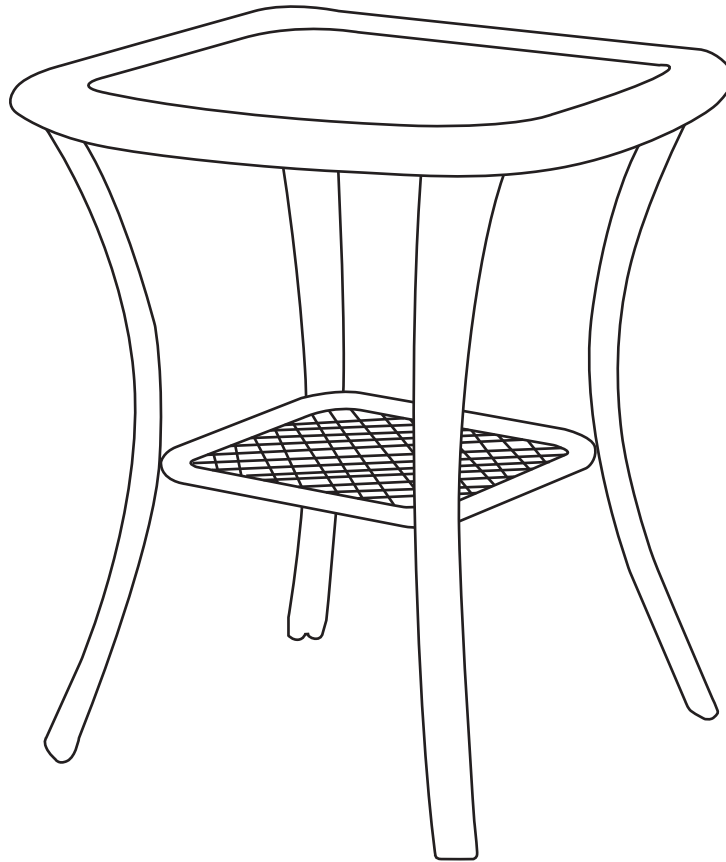

Assembly Video

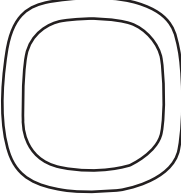
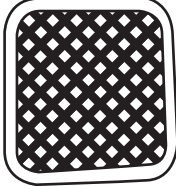
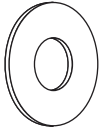
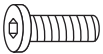

For any missing or damaging parts, hardware, or any other problems, WELCOME to email us at:
SERVICE@RILYSON.COM

* Don't fully tighten all the bolts till the very end!

	PART LIST	DESCRIPTON	QTY
A		LEG	4
B		TABLE TOP	1
C		TRAY	1
D		WASHER -- M6	12
E		BOLT -- M6 x 12mm	12
F		HEX WRENCH	1

PRE-ASSEMBLY PREPARATION:

- Please read through the instructions before beginning assembly.
- Clear out the space for assembly and lay out all of the parts based on the Parts List, extra room will allow you to easily determine if all the pieces are present.
- Keep small parts and pieces away from children until fully assembled.

Step 1: Attach 4pcs legs (A) to table top (B) with 8pcs bolts (E) and 8pcs washers (D).

* Do not fully tighten bolts until the entire frame is assembled

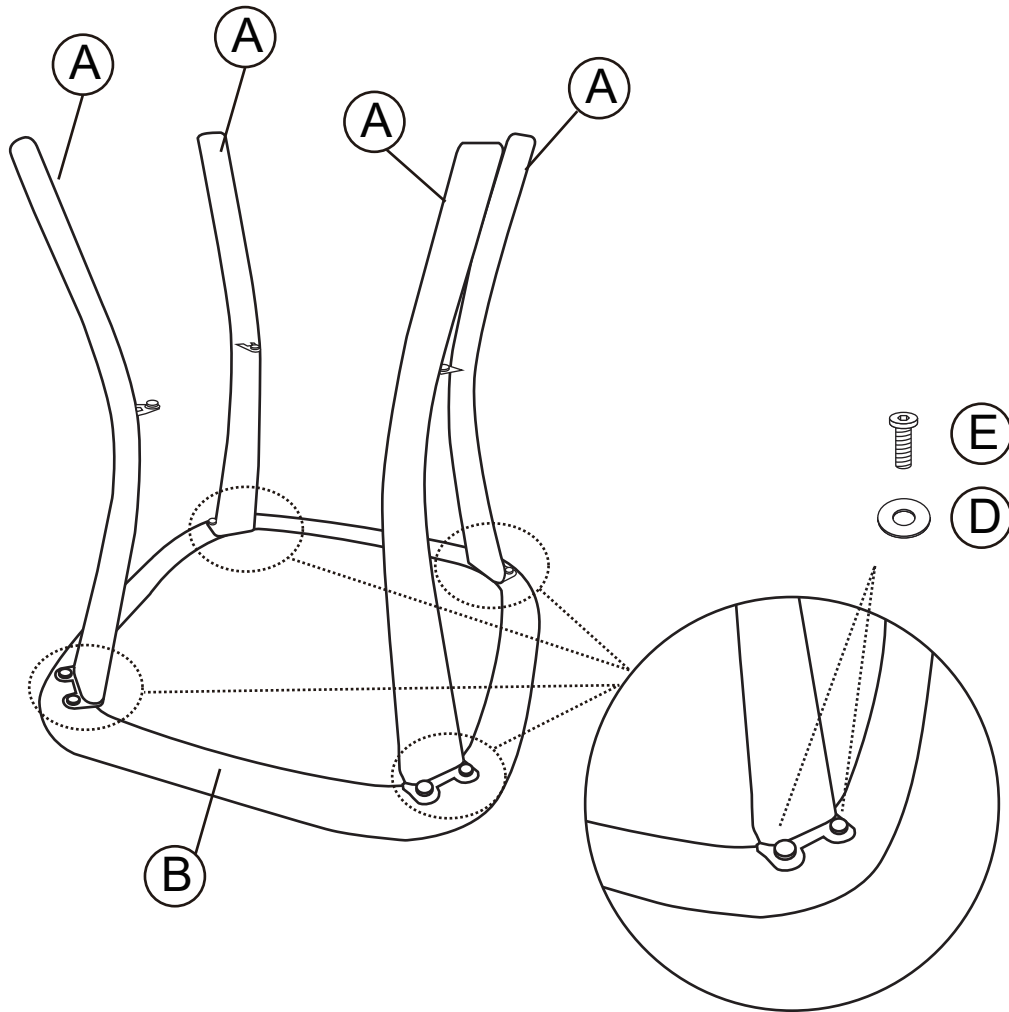

Step 2: Attached tray (C) to legs (A) with 4pcs bolts (E) and 4pcs washers (D).

Turn over the assembled table. Verify the alignment and adjust, now fully tighten all the bolts using Hex Wrench (F)

