

Slant leg bench

Assembly Instructions

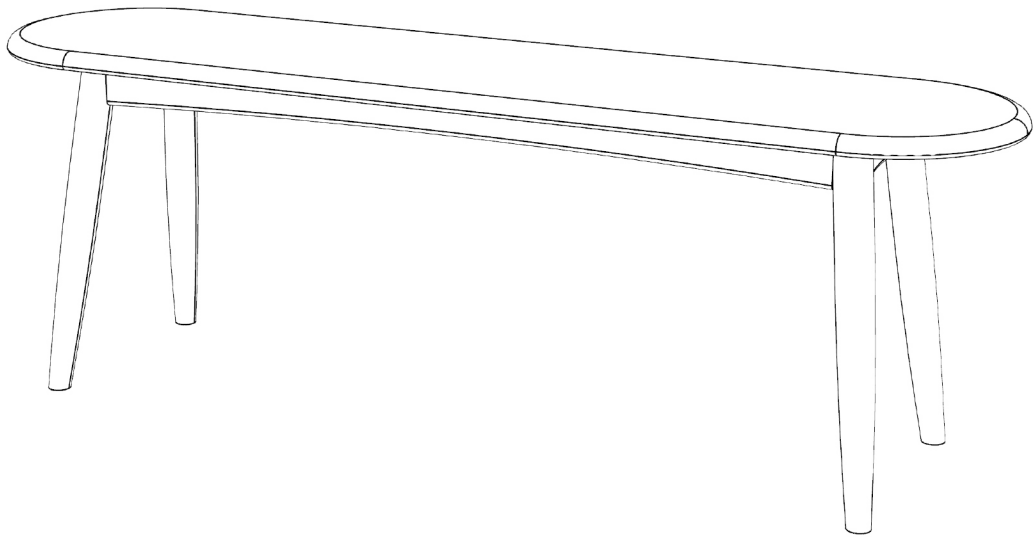





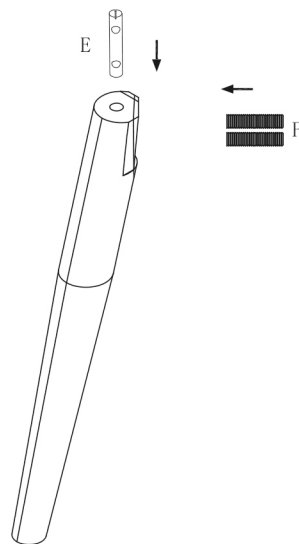

The assembly steps are as follows:

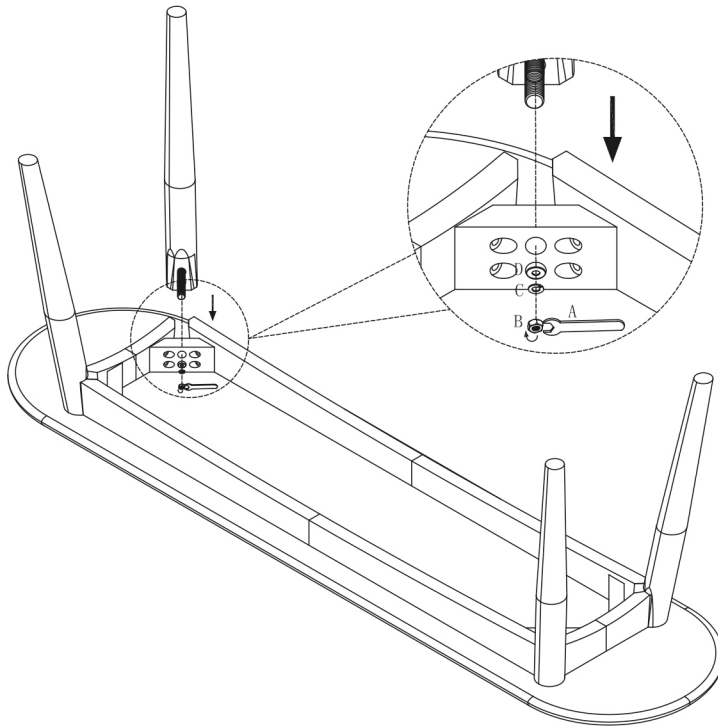
Step 1: As shown in the diagram below, insert E into the hole at the top of each leg and then screw F into the two holes of E.

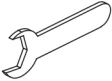

Step 2: Lay the bench top facedown on a flat, clean and non-abrasive surface. Attach the legs to the bench top as shown in the diagram below. Make sure you fit the hardware together in the correct order.

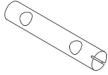

					
A. Open-end wrench x 1	B. Nuts (Ø6) x 8	C. Split washers (Ø6) x 8	D. Flat washers (Ø6) x 8	E. Twin hole cross dowel barrel nuts (Ø10) x 4	F. Grub screws (Ø6) x 8