

Solar Street Light Camera XA01 Quick Start Manual

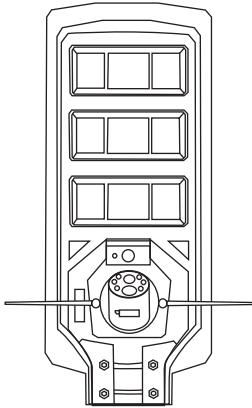

Packing List

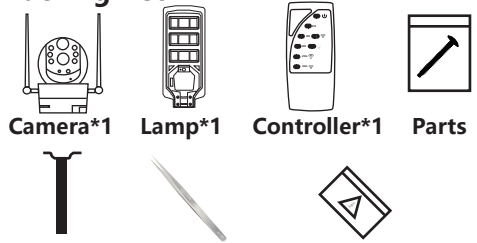

Bracket*1 Tweezers*1 Warranty Card*1

Interface Indicator Schematic

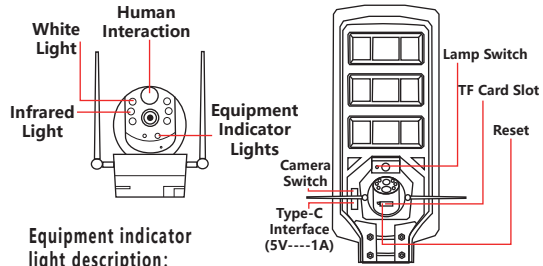

Equipment indicator light description:

1. The device indicator light is constantly on: The device is running normally
2. The device indicator light is off: The device has disconnected from the network or lost power
3. The device indicator light is flashing: The device is turned on or restarted
4. Infrared light on: Enters night vision mode

Product Installation

I. Camera

Connect to USB port and tighten clockwise.

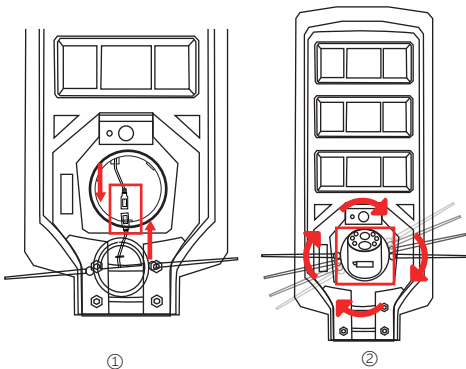

II. Equipment Initialisation
Turn on the camera switch and wait for the prompt tone to sound.

Long press the reset button.

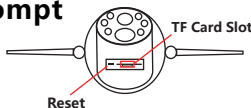

Download APP



Search for 'V380 Pro' in the app shop or scan the QR code to download and install the latest version of the app.

User Registration

1. Open V380 Pro APP to complete account registration and login. Click "Add Device" on the home page.
2. Use your Phone to scan the QR code on the camera.

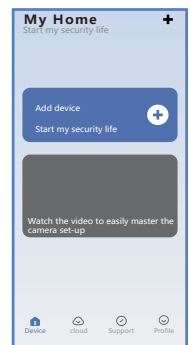

QR code distribution network specific operation

1. Click on the WI-FI camera at the bottom of the interface;
2. Click on the QR code to distribute the network;
3. Enter the LAN name and password;
4. Aim the QR code generated by your cell phone at the camera
At a distance of 10~30cm, after successful code scanning
The device will prompt "Received configuration information".

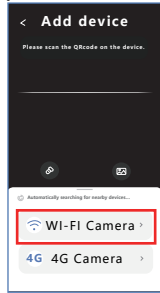

①



②

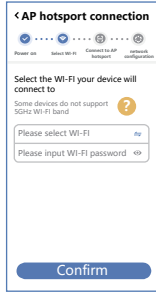

③

AP distribution network specific operations

1. Click on the WI-FI device at the bottom of the interface;
2. Click AP Hotspot Connection;
3. Enter the LAN name and password
4. According to the cell phone interface prompts to operate can be

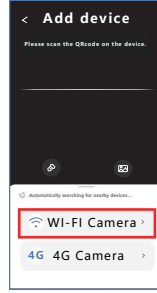

①

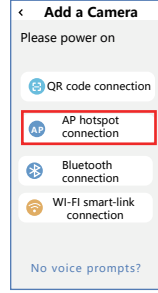

②

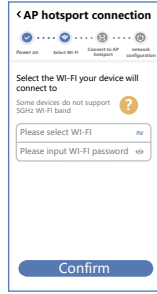

③



④

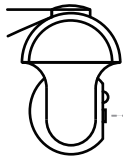

Note: All the above operations require the phone to be connected to the LAN

V1.3.7.20241123_C

FAQ

- Q: Camera cannot connect to WI-FI?
- A: Before connecting the device to WIFI, please press and hold the reset button to initialize the device, beep: Reset Successful is rebooting the camera, retry again!
- Q: Is there a message "Device offline" in the device list?
- A: Please reboot the camera to make sure that the camera can start normally and is connected to WiFi.

Caveat

- The device only supports 2.4GHz WiFi, please make sure your phone is connected to 2.4GHz WiFi before pairing;
- Regarding Micro SD card recording, when the recording capacity reaches the upper limit, the recording file with the earliest recording time will be automatically overwritten;
- Prolonged use of the camera in non-conventional environments (high temperatures, high humidity, large amounts of dust or smoke, etc.) will accelerate the deterioration or damage of the camera;
- V380 Pro APP and device firmware will be updated from time to time, for your best experience, please update APP and upgrade device firmware in time.

Note: Please do not open the waterproof cover at the Type-C charging port, and please install it in time after connecting the line.

Warranty Card

User ID: _____

Full address: _____

telephones: _____ zip code: _____

E-mail: _____

Product Model: _____

SN code: _____

date of manufacture: _____

Date of purchase: _____

Free Warranty: _____

If you have other requirements, please fill in below:

Dates	Fault Phenomenon	Repairs Serial Number Changes