

# Montageanleitung | Instructions de montage Assembly Instructions | Instrucciones de montaje

V4.0

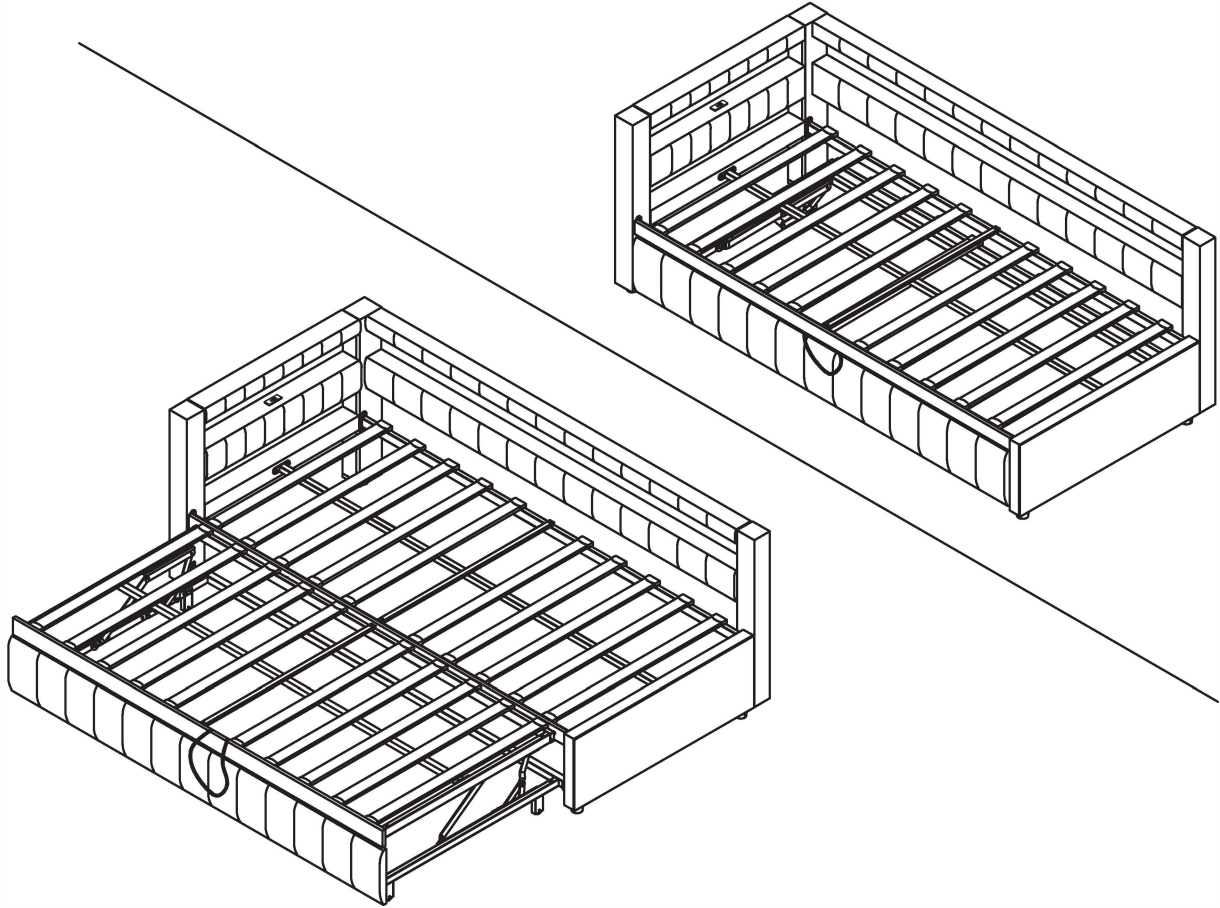

**UK  
CA**

**GB** This set comes in 2 boxes. If you do not receive a full set of 2 boxes, please contact our customer service.

**DE** Dieses Set wird in 2 Schachteln geliefert. Wenn Sie nicht ein komplettes Set von 2 Boxen erhalten, kontaktieren Sie bitte unseren Kundenservice.

**FR** Ce set est livré en 2 boîtes. Si vous ne recevez pas un jeu complet de 2 boîtes, veuillez contacter notre service clientèle.

## English

**IMPORTANT ! KEEP FOR FUTURE REFERENCE : READ CAREFULLY**

- To be assembled by an adult. Assembly must be checked by an adult before use
- **WARNING !** Keep all screws, small parts and plastic bags out of the reach of children
- Properly identify all parts before assembling
- Never use your item if any of its parts are broken or missing
- Should any problems arise, please contact our After Sales Service
- Manufacturer's instructions shall be followed at all times
- Care: Clean with a soft, dry cloth. In case of larger stains, carefully rub with a slightly damp, non-abrasive sponge
- Do not jump on the bed

## Français

**IMPORTANT ! CONSERVER POUR RÉFÉRENCE ULTÉRIEURE : LIRE ATTENTIVEMENT**

- Le montage doit être effectué par un adulte. Le montage doit être vérifié par un adulte avant utilisation
- **ATTENTION !** Tenir les vis, les petites pièces et les sachets en plastique hors de portée des enfants
- Identifiez correctement toutes les pièces avant de les assembler
- N'utilisez jamais votre article si l'une de ses pièces est cassée ou manquante
- En cas de problème, veuillez contacter notre service après-vente
- Les instructions du fabricant doivent être respectées à tout moment
- Entretien : nettoyer avec un chiffon doux et sec. En cas de taches plus importantes, frotter soigneusement avec une éponge non abrasive légèrement humide. légèrement humide et non abrasive
- Ne pas sauter sur le lit

## Deutsch

**WICHTIG ! ZUM SPÄTEREN NACHSCHLAGEN AUFBEWAHREN: SORGFÄLTIG LESEN**

- Muss von einem Erwachsenen zusammengebaut werden. Der Zusammenbau muss vor dem Gebrauch von einem Erwachsenen überprüft werden
- **WARNUNG!** Bewahren Sie alle Schrauben, Kleinteile und Plastikbeutel außerhalb der Reichweite von Kindern auf
- Kennzeichnen Sie vor dem Zusammenbau alle Teile richtig.
- Benutzen Sie Ihren Artikel niemals, wenn Teile gebrochen sind oder fehlen
- Sollten Probleme auftreten, wenden Sie sich bitte an unseren Kundendienst
- Die Anweisungen des Herstellers sind stets zu befolgen
- Pflege: Mit einem weichen, trockenen Tuch reinigen. Bei größeren Flecken vorsichtig mit einem leicht feuchten, nicht scheuernden Schwamm abreiben. nicht scheuernden Schwamm
- Nicht auf das Bett springen



## More Tips



1

**English** - Before installation, you can place the parts on a carpet or other soft fabric, in order to avoid damaging your floor.

**Français** - Avant l'installation, vous pouvez placer les pièces sur un tapis ou un autre tissu doux, afin d'éviter d'endommager votre sol.

**Deutsch** - Vor der Installation können Sie die Teile auf einen Teppich oder ein anderes weiches Material legen, um eine Beschädigung Ihres Fußbodens zu vermeiden.

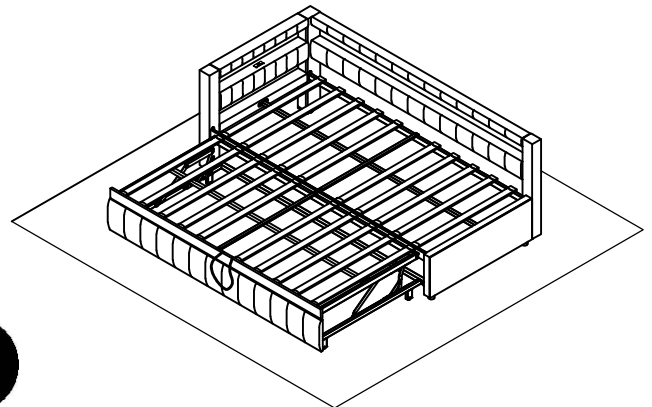
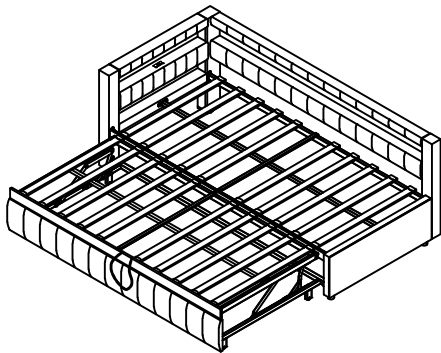

2

**English** - For your and your family's safety, please do not jump on beds, especially with hydraulic structures. When need to move bed, please work with more than one person to lift, not push, to avoid scratching your floor and hurting the stability of the bed.

**Français** - Pour votre sécurité et celle de votre famille, ne sautez pas sur les lits, en particulier sur les structures hydrauliques. Lorsqu'il est nécessaire de déplacer le lit, il est préférable de travailler à plusieurs pour le soulever, et non pour le pousser, afin d'éviter de rayer le sol et de nuire à la stabilité du lit.

**Deutsch** - Zu Ihrer Sicherheit und der Ihrer Familie sollten Sie nicht auf Betten springen, insbesondere bei hydraulischen Konstruktionen. Wenn Sie das Bett bewegen müssen, heben Sie es bitte mit mehreren Personen an und schieben Sie es nicht, um den Boden nicht zu verkratzen und die Stabilität des Bettes nicht zu beeinträchtigen.

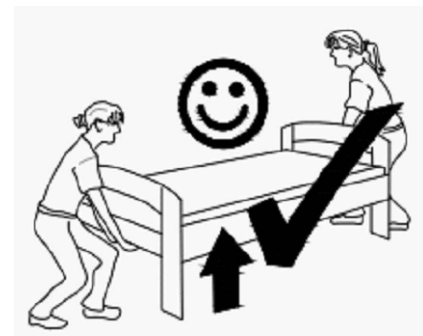

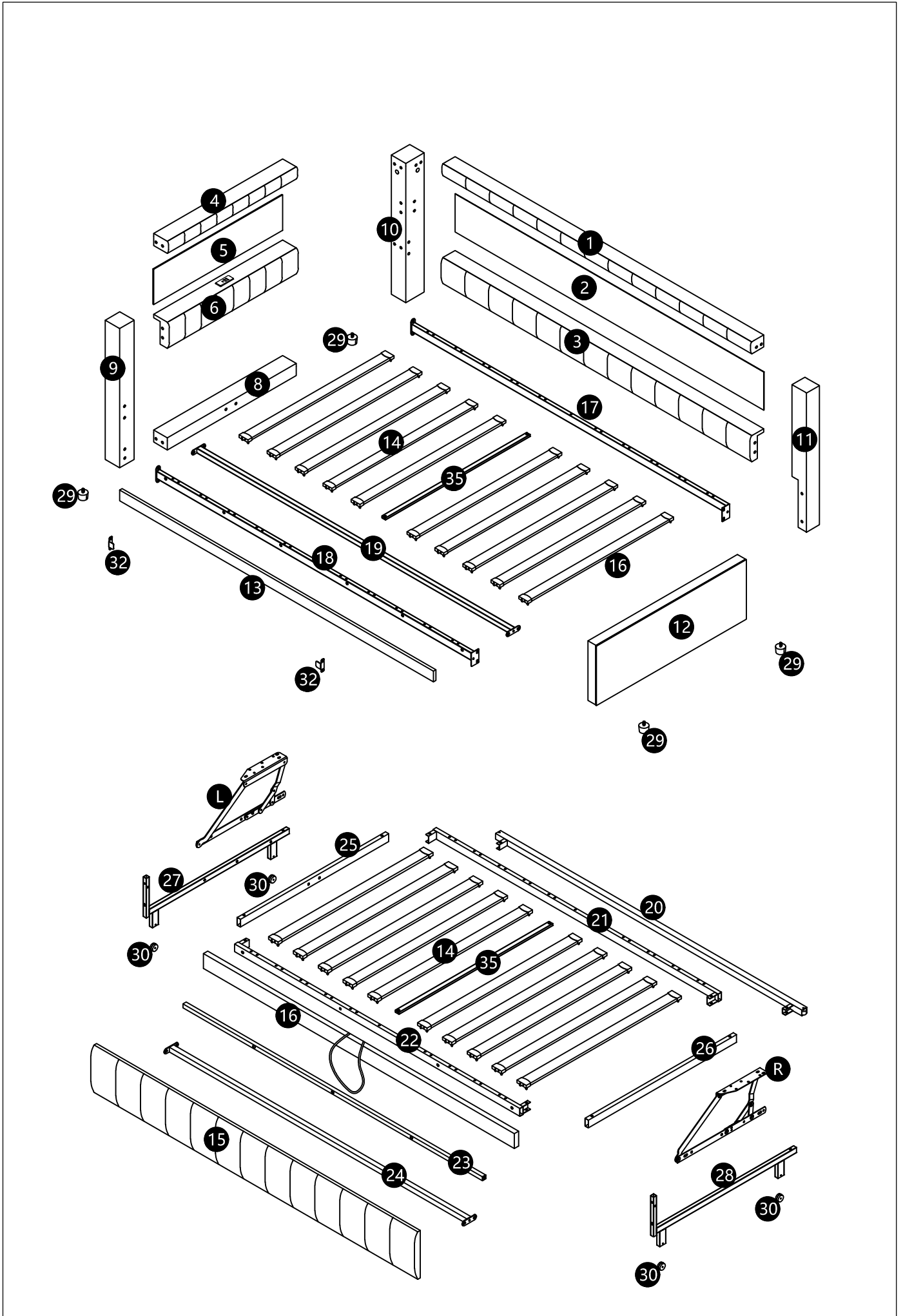

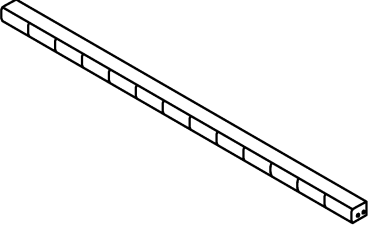
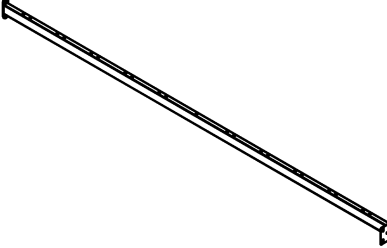
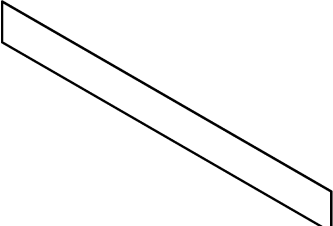
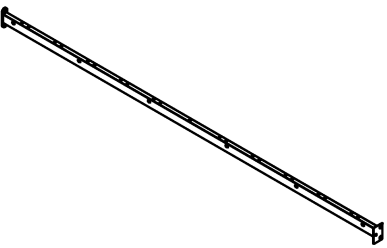
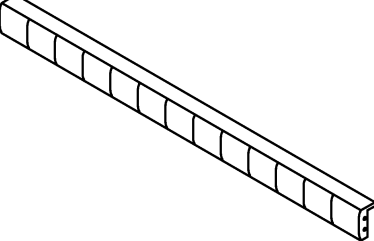
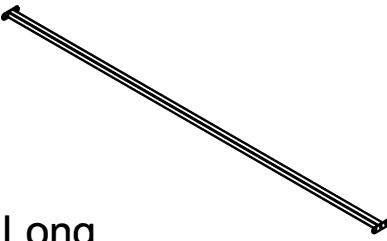
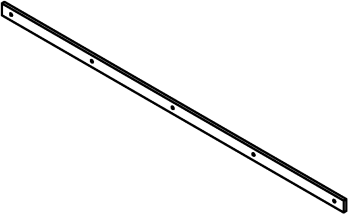
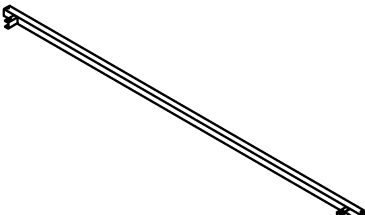
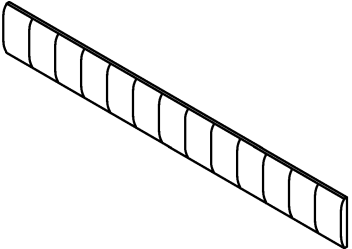
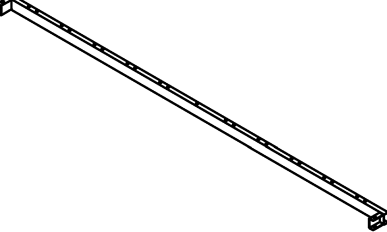
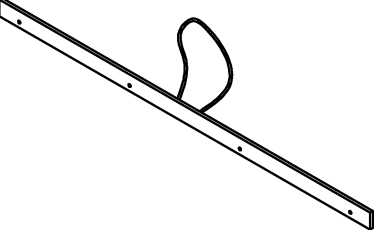
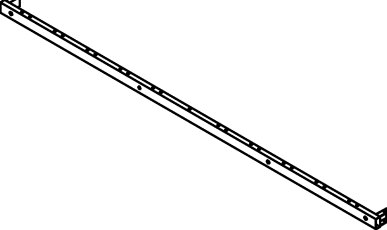
1		X1	17		X1
2		X1	18		X1
3		X1	19	Long 	X1
13		X1	20		X1
15		X1	21		X1
16		X1	22		X1

23

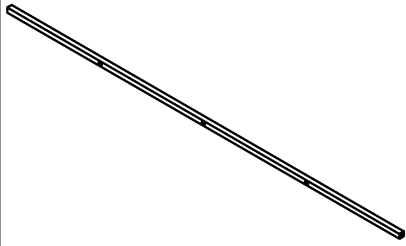

X1



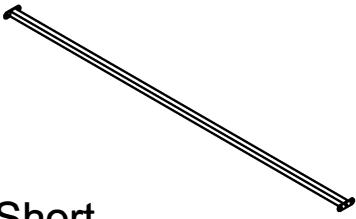

24



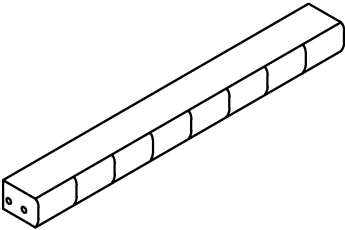
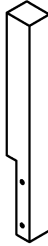
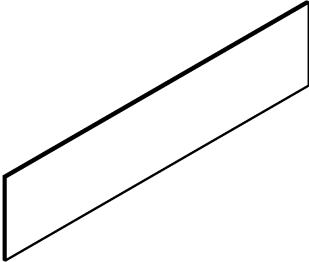
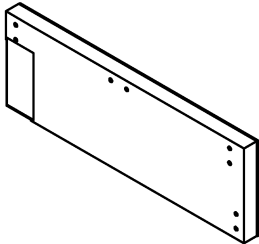
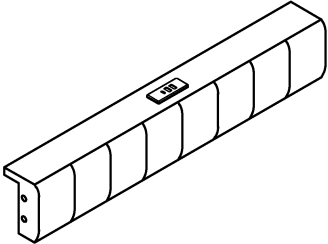
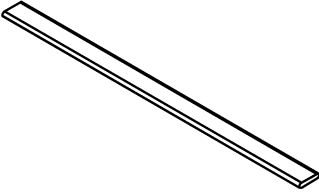
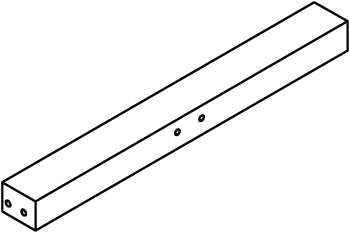
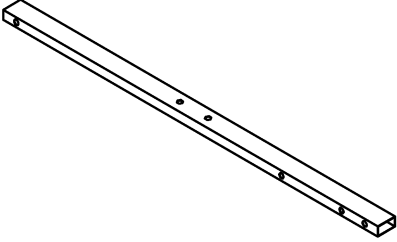
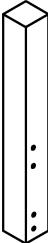
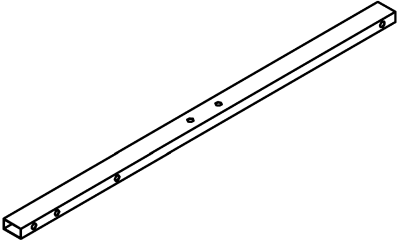
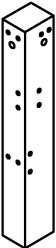
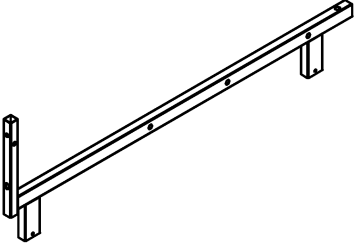

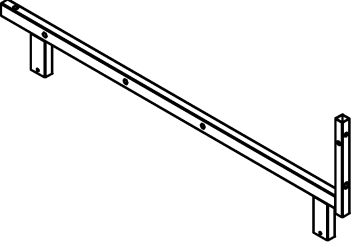
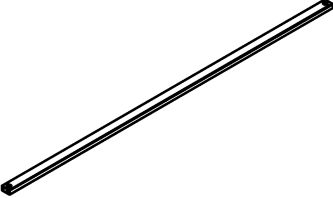
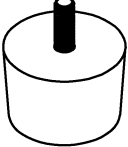
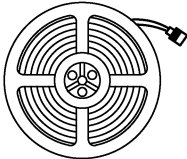

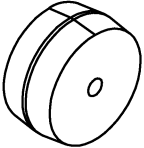

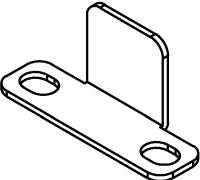
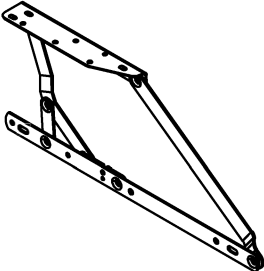
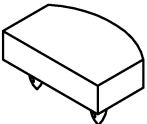
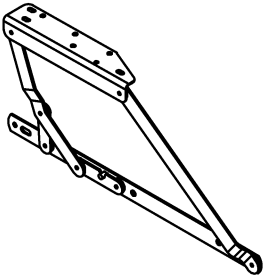





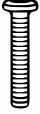

Short

X1

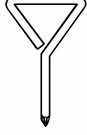
4		X1	11		X1
5		X1	12		X1
6		X1	14		X20
8		X1	25		X1
9		X1	26		X1
10		X1	27		X1

28		X1	35		X2
29		X4	36	 Light strip	X1
30		X2	39	 Power cord	X1
31		X4	40		X1
32		X2	L		X1
33		X40	R		X1

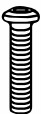
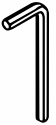
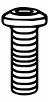
# Hardware List-Hardware-Liste-Liste du matériel

<b>A</b>	 M6*20	X10+1	<b>G</b>	 M8*35	X32+1	<b>N</b>	 M5	X1
<b>B</b>	 M6*20	X6+1	<b>H</b>	 M5*40	X6+1	<b>O</b>		X2+1
<b>C</b>	 M6*25	X6+1	<b>J</b>	 M5	X6+1	<b>P</b>		X1
<b>D</b>	 M6*35	X4+1	<b>K</b>	 M3*12	X2+1	<b>Q</b>	 M4*16	X2+1
<b>E</b>	 M6*40	X9+1	<b>L</b>	 M6	X2			
<b>F</b>	 M8*20	X20+2	<b>M</b>	 M8	X1			

# 1

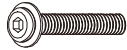

M8X35  
GX12pcs



M8  
MX1pc

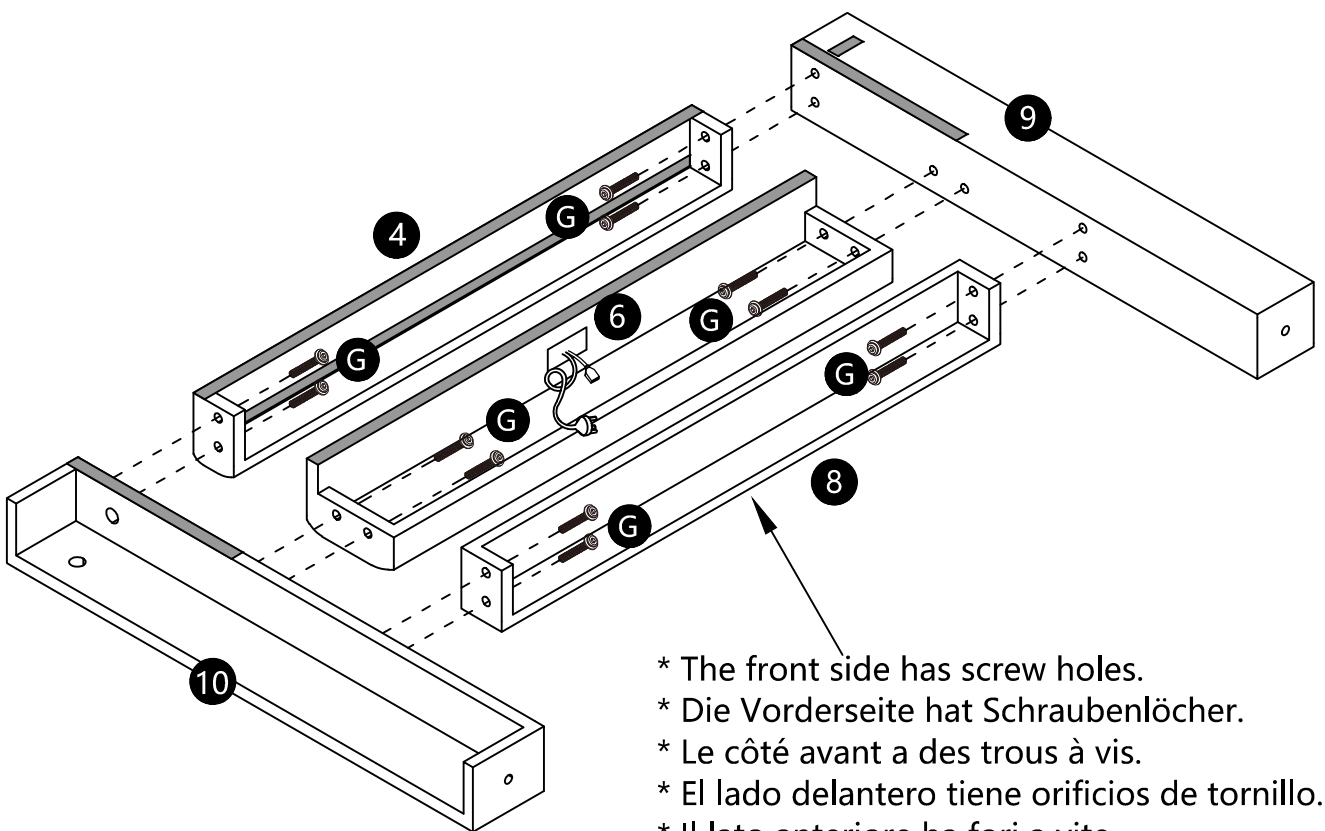

- \* The front side has screw holes.
- \* Die Vorderseite hat Schraubenlöcher.
- \* Le côté avant a des trous à vis.
- \* El lado delantero tiene orificios de tornillo.
- \* Il lato anteriore ha fori a vite.

# 2



M8X20  
FX2pcs



M8  
MX1pc



OX1pc



29X2pcs

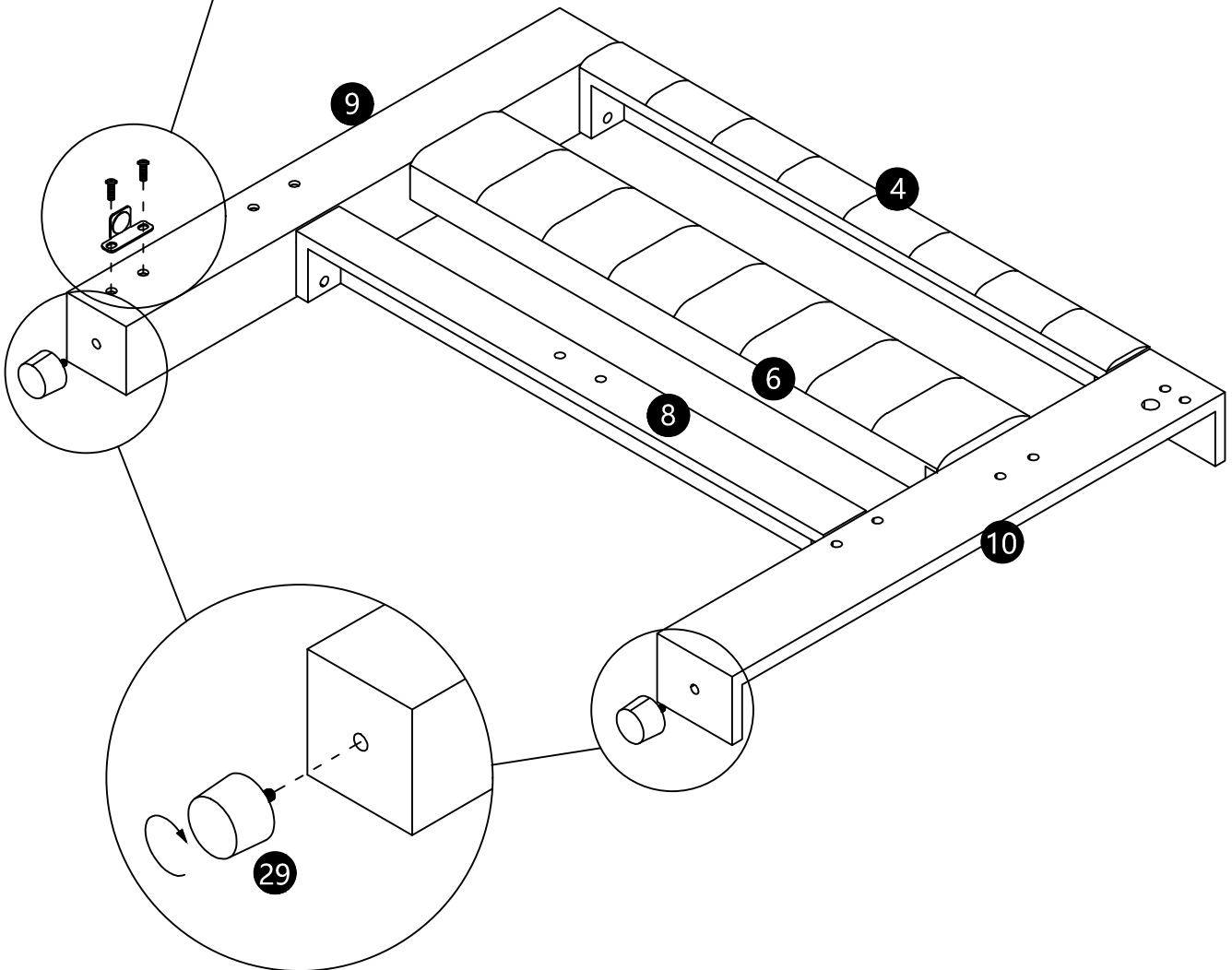
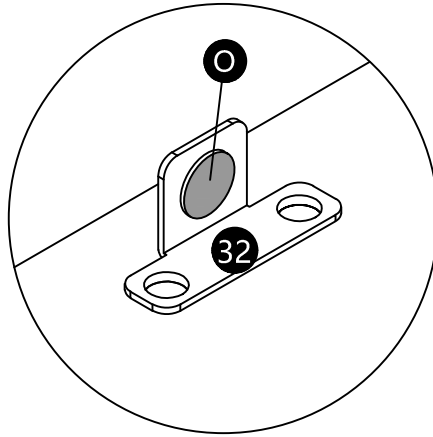
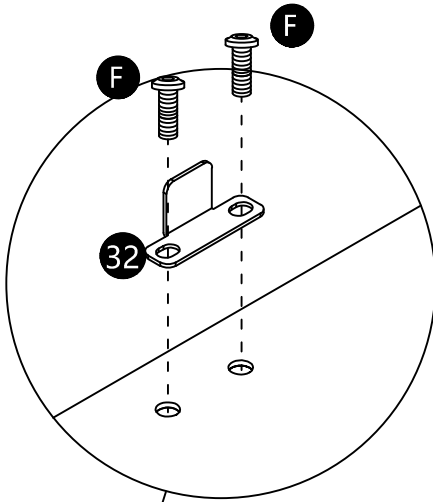

**3**

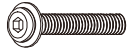

M8X35  
GX2pcs



M8  
MX1pc

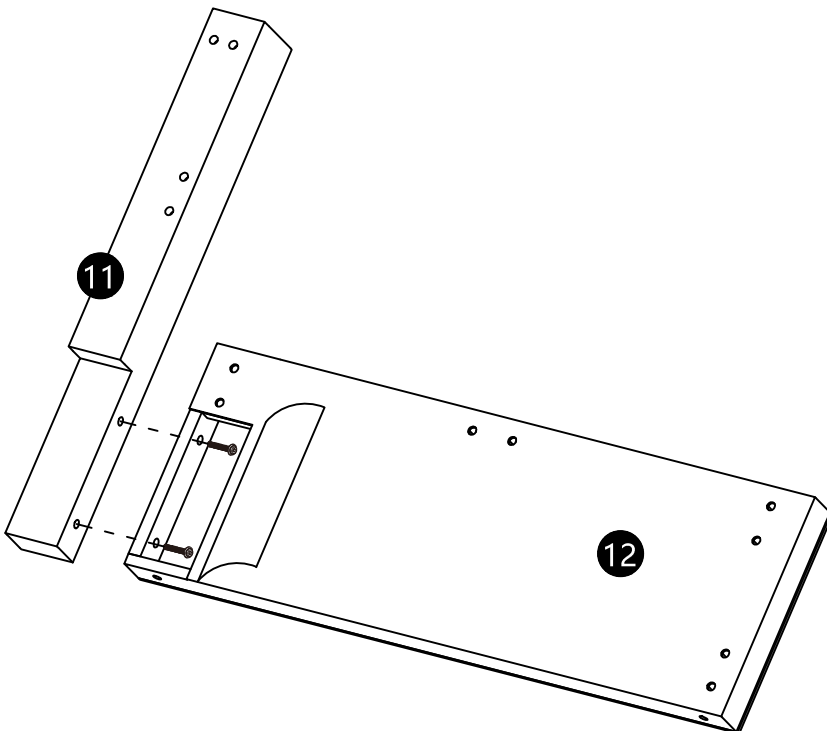
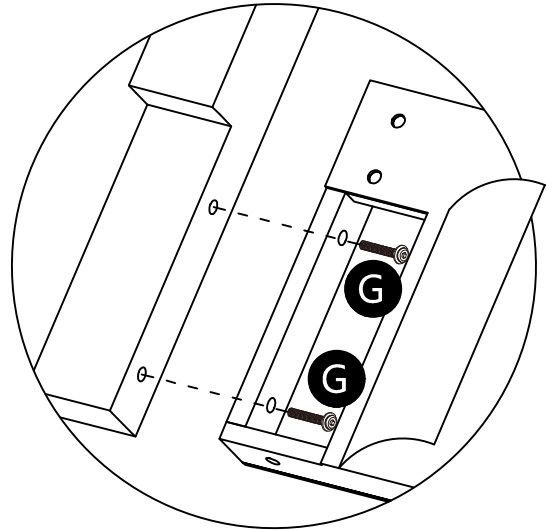
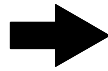
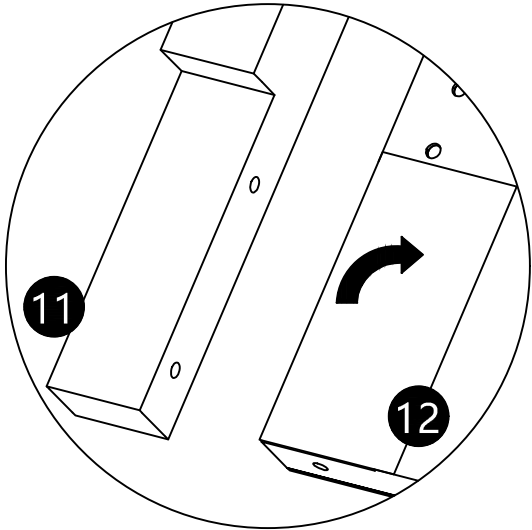

# 4

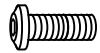

M8X20  
FX2pcs



M8  
MX1pc



OX1pc



29X2pcs

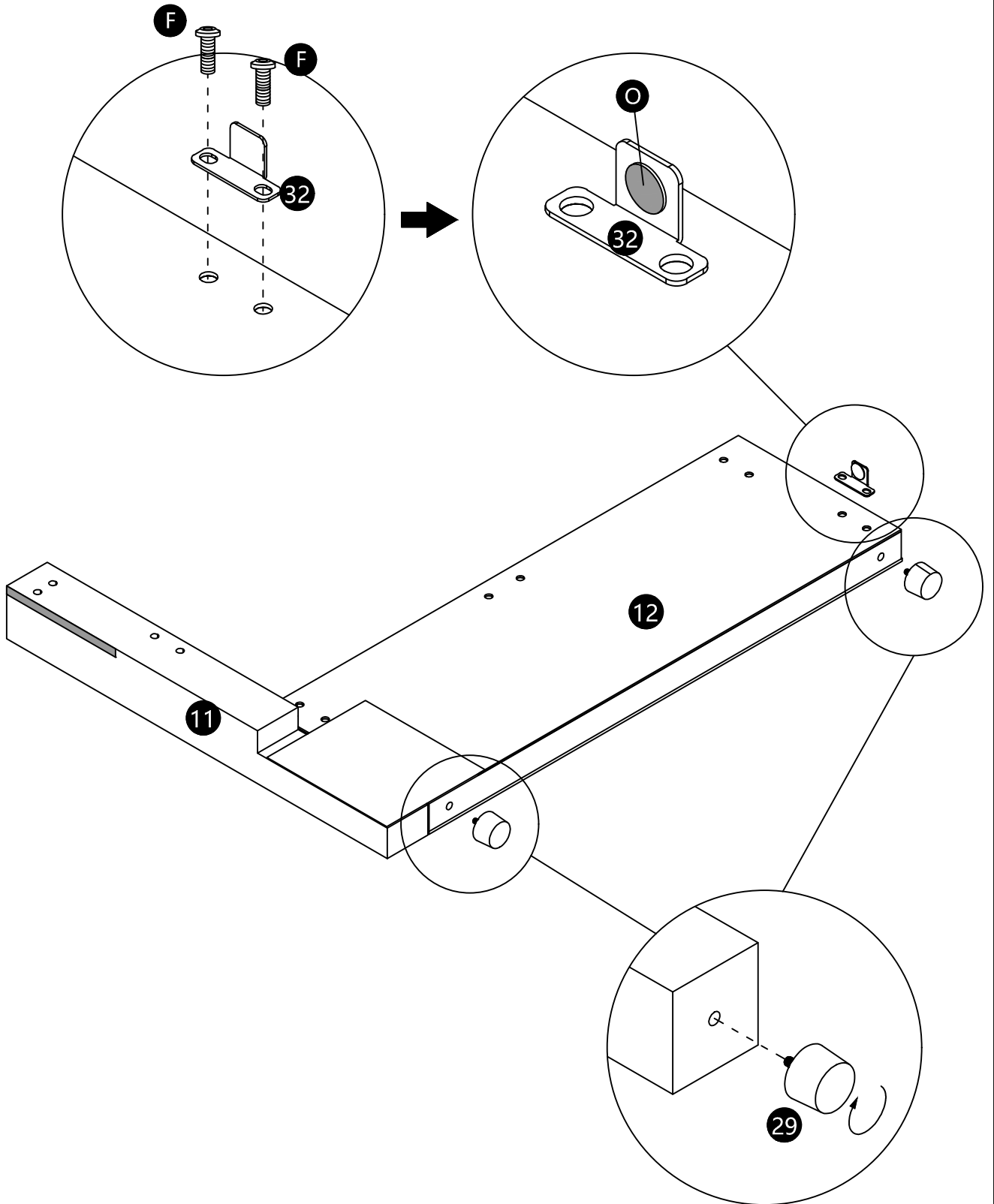



# 7

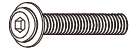

M8X35  
GX6pcs



M8  
MX1pc

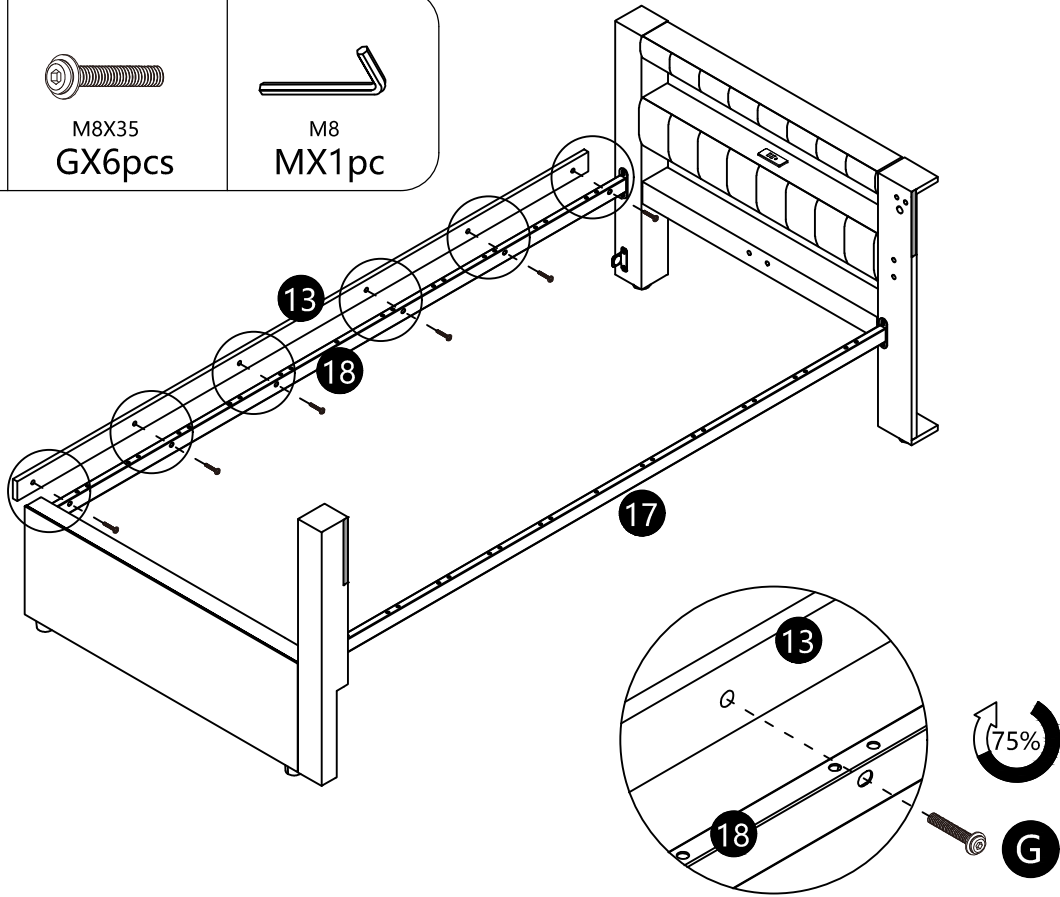

# 8



M8X20  
FX4pcs



M8  
MX1pc

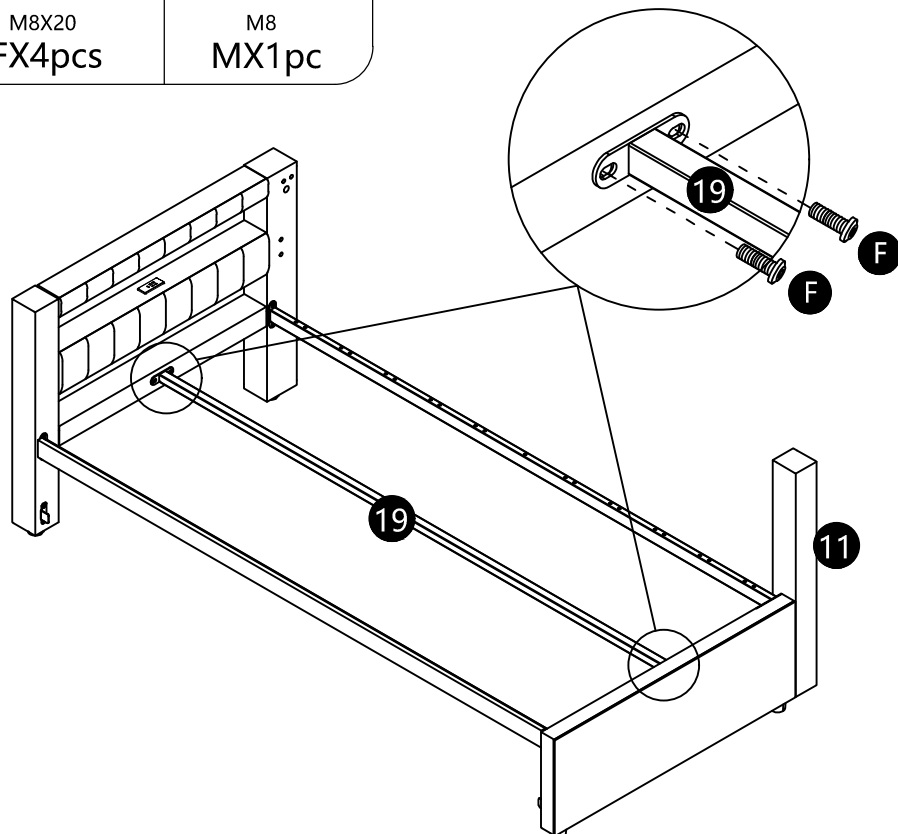

# 9

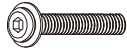

M8X35  
GX8pcs



M8  
MX1pc

- \*Fully tighten all the screws that have not yet been secured.
- \*Alle Schrauben, die noch nicht befestigt wurden, vollständig festziehen.
- \*Serrez complètement toutes les vis qui n'ont pas encore été fixées.
- \*Aprete completamente todos los tornillos que aún no han sido asegurados.
- \*Serrare completamente tutte le viti che non sono ancora state fissate.

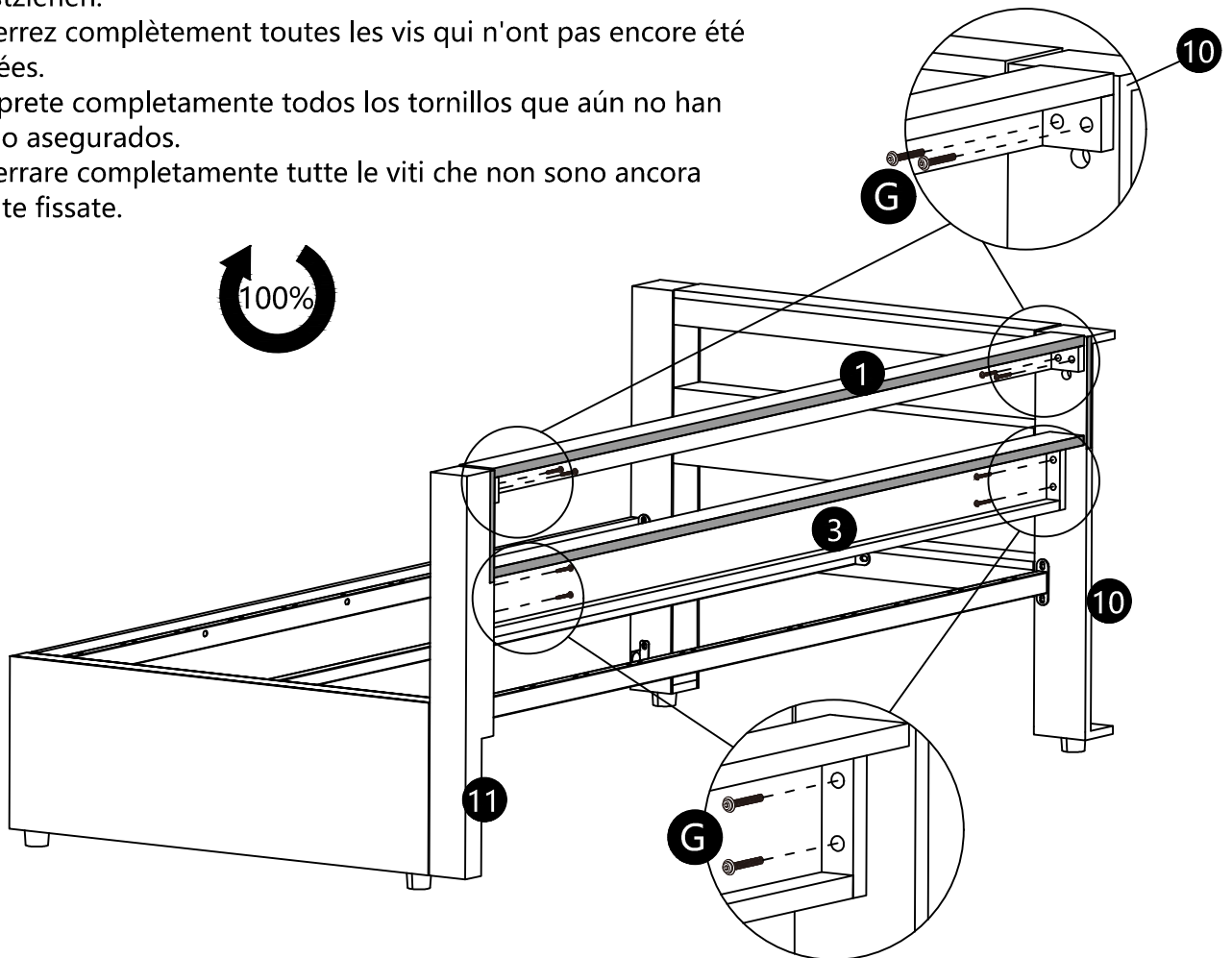

# 10

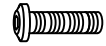

M6\*25  
CX2pcs



M6  
LX1pc

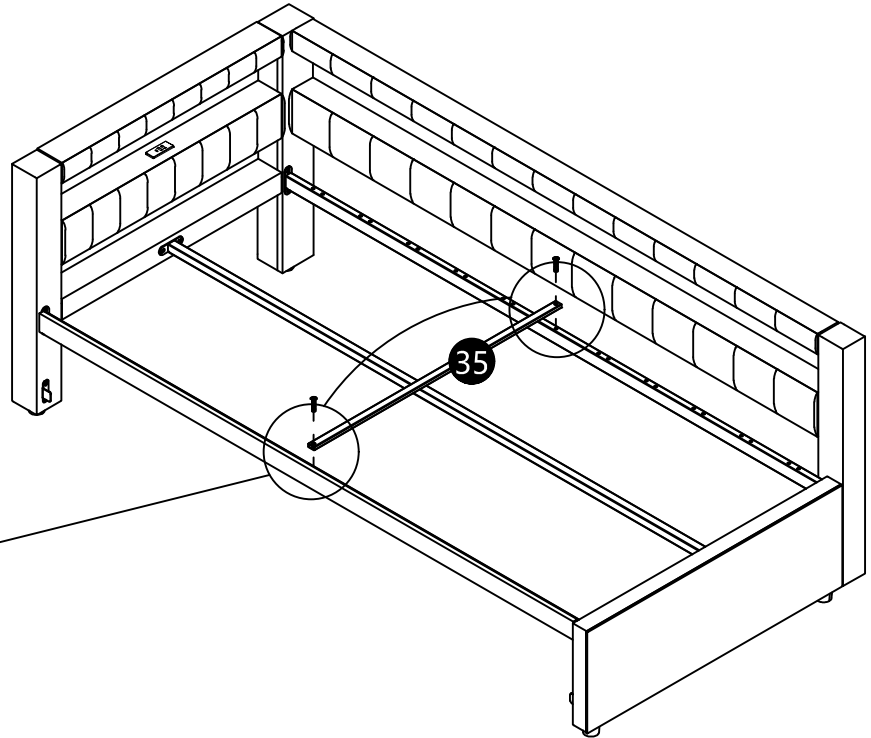
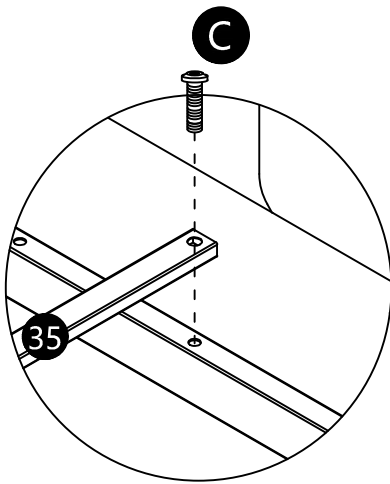

# 11

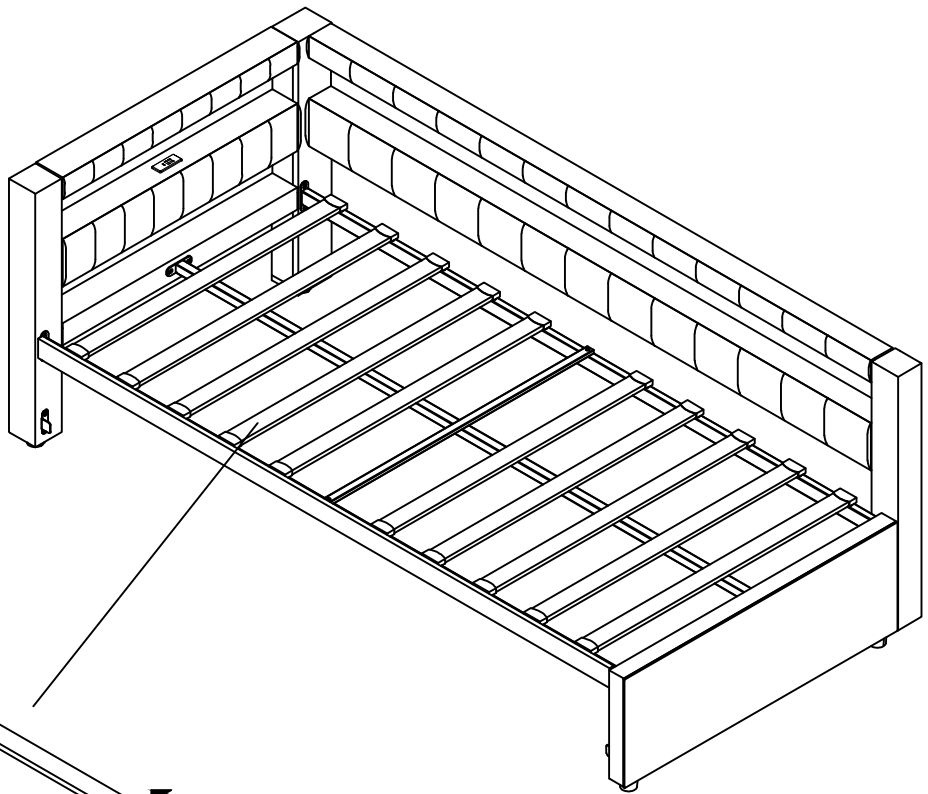

33

14

X10

33

**12**

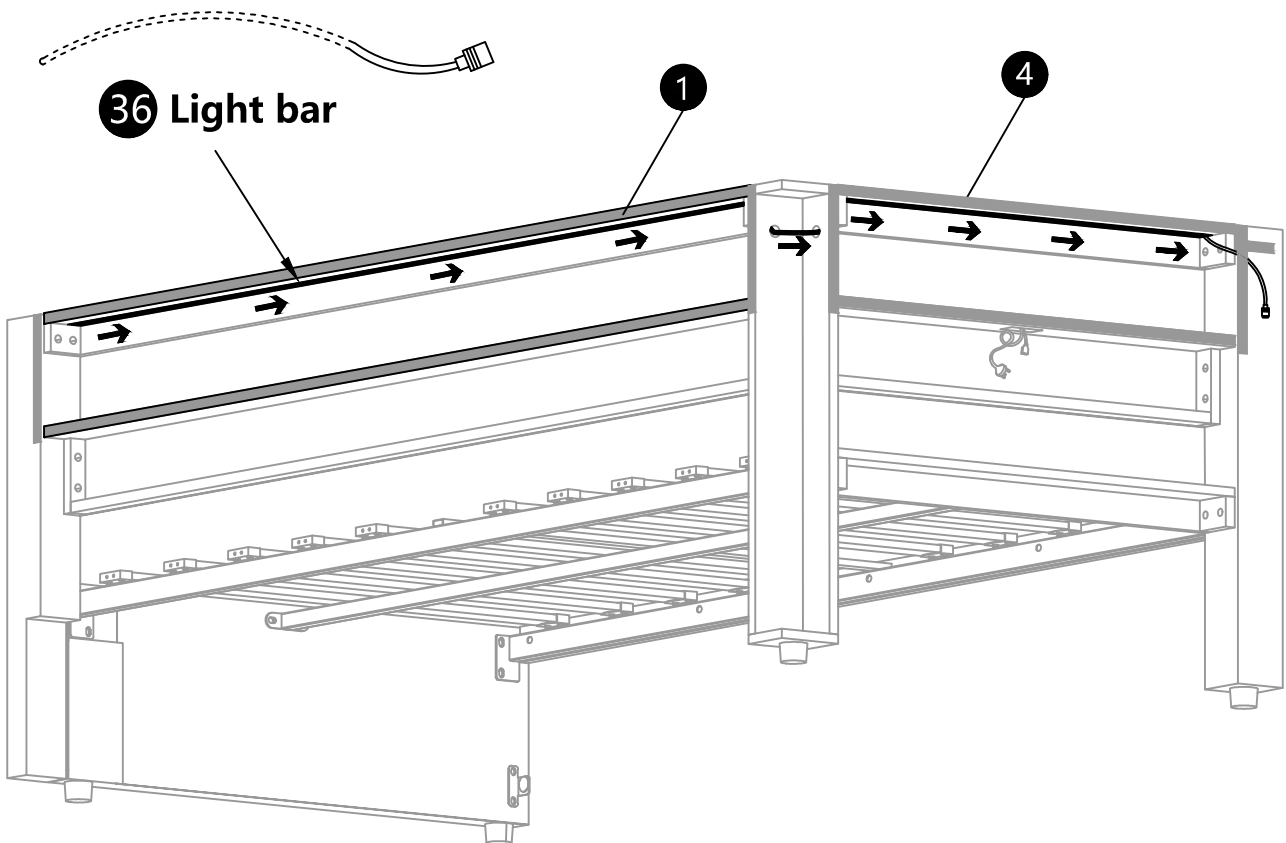
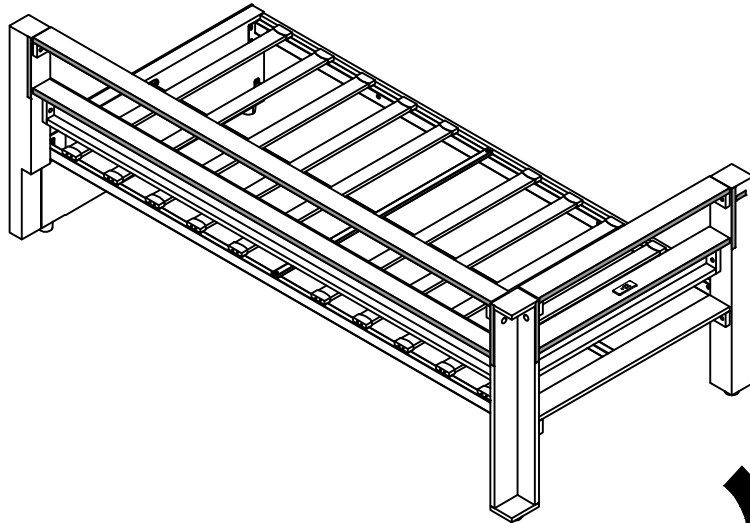
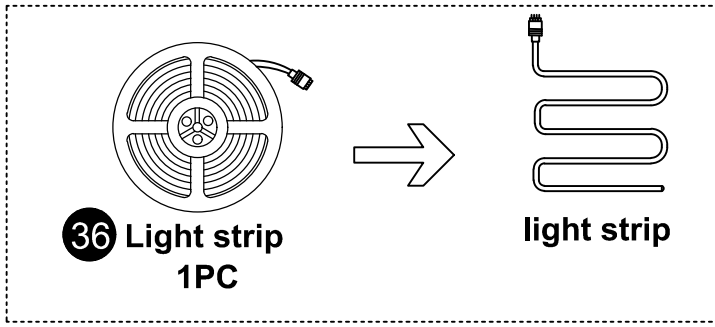

# 13

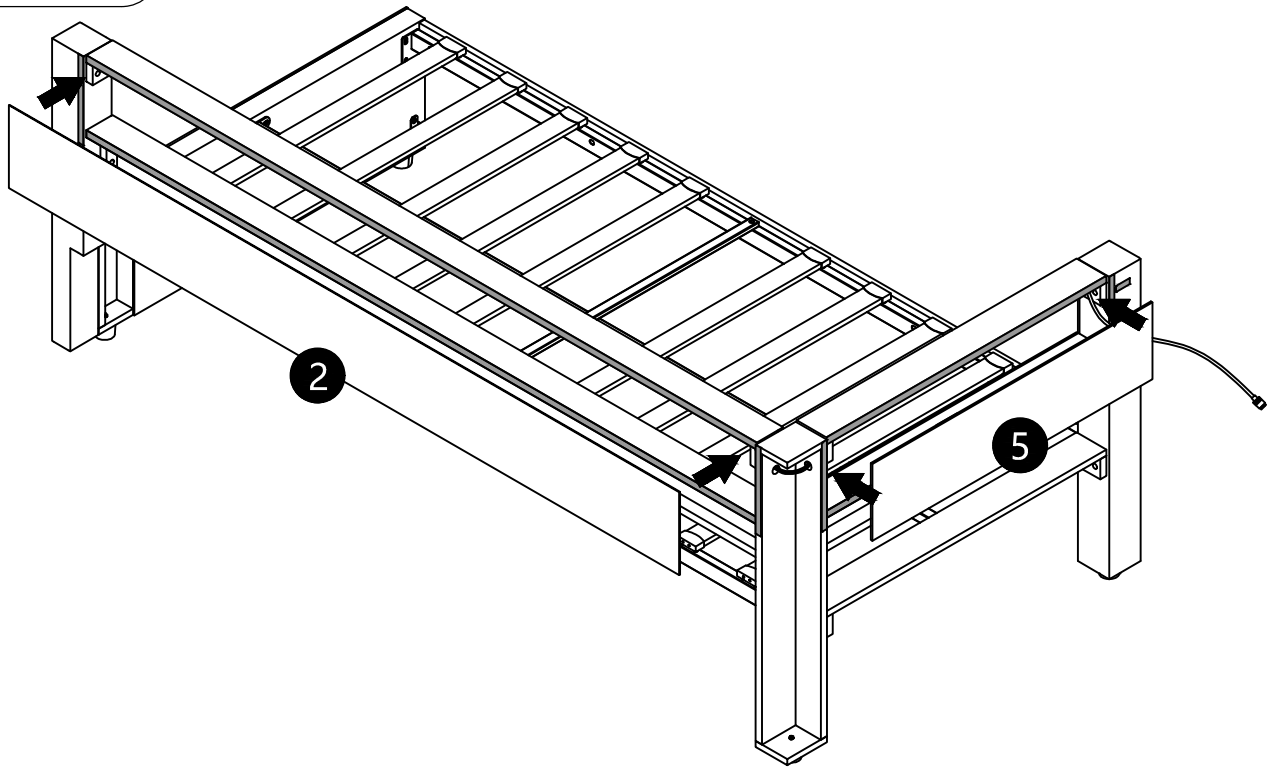

# 14



M4\*16  
QX2pcs

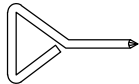

PX1pc

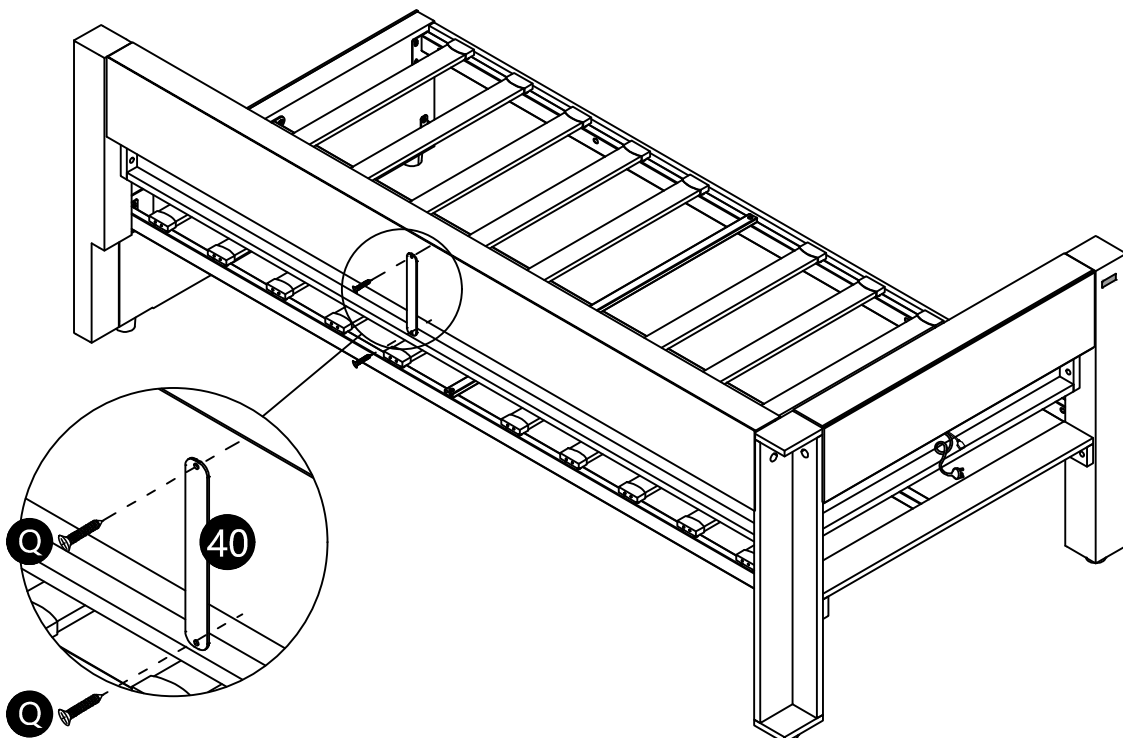

15

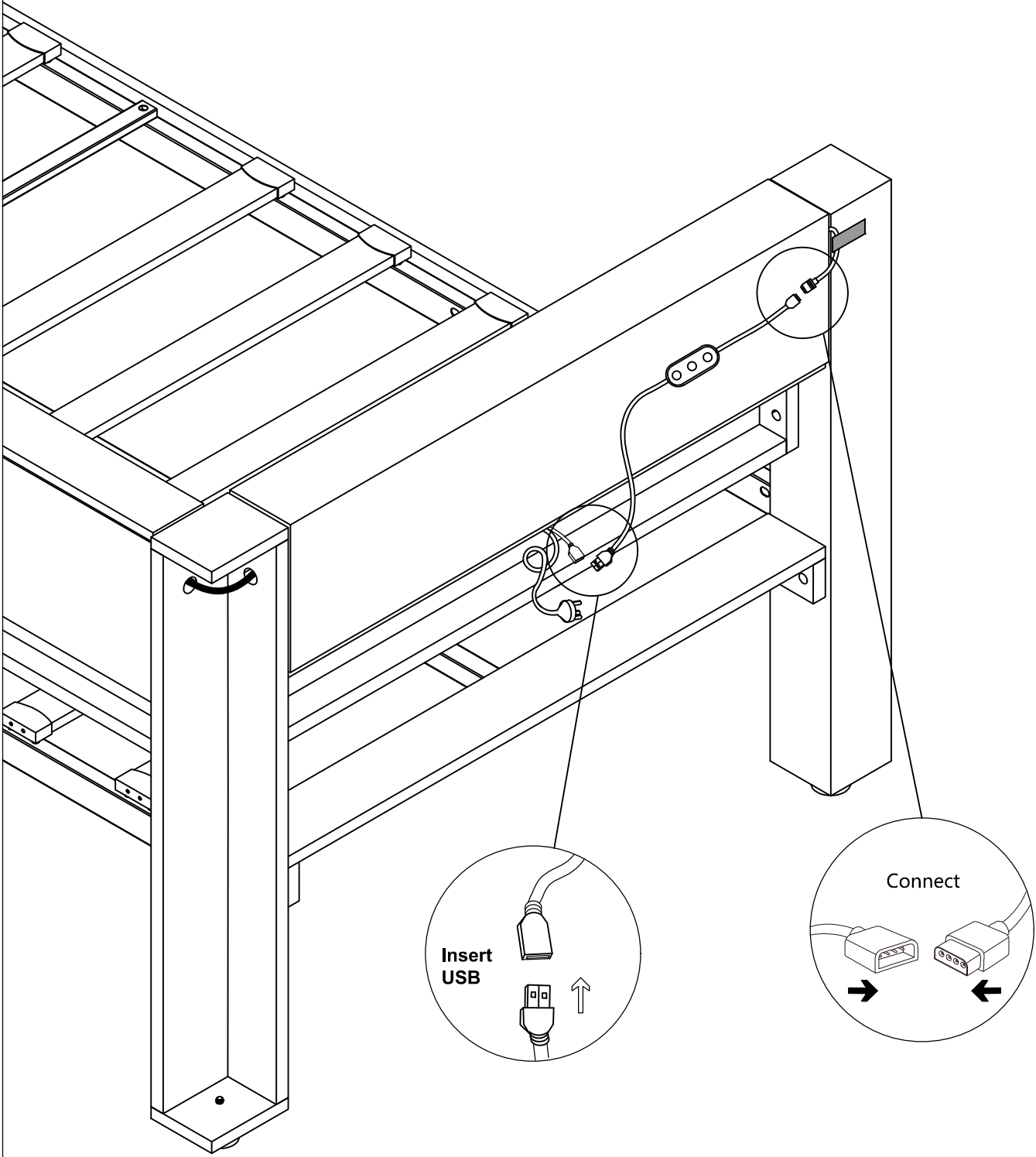
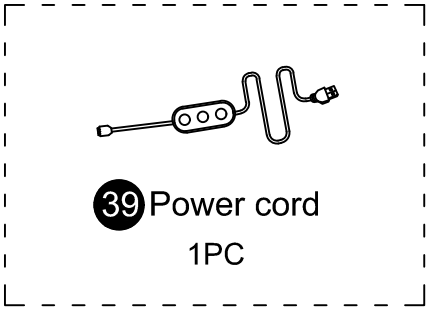

# 16

M6\*20  
AX4pcs

M6  
LX1pc

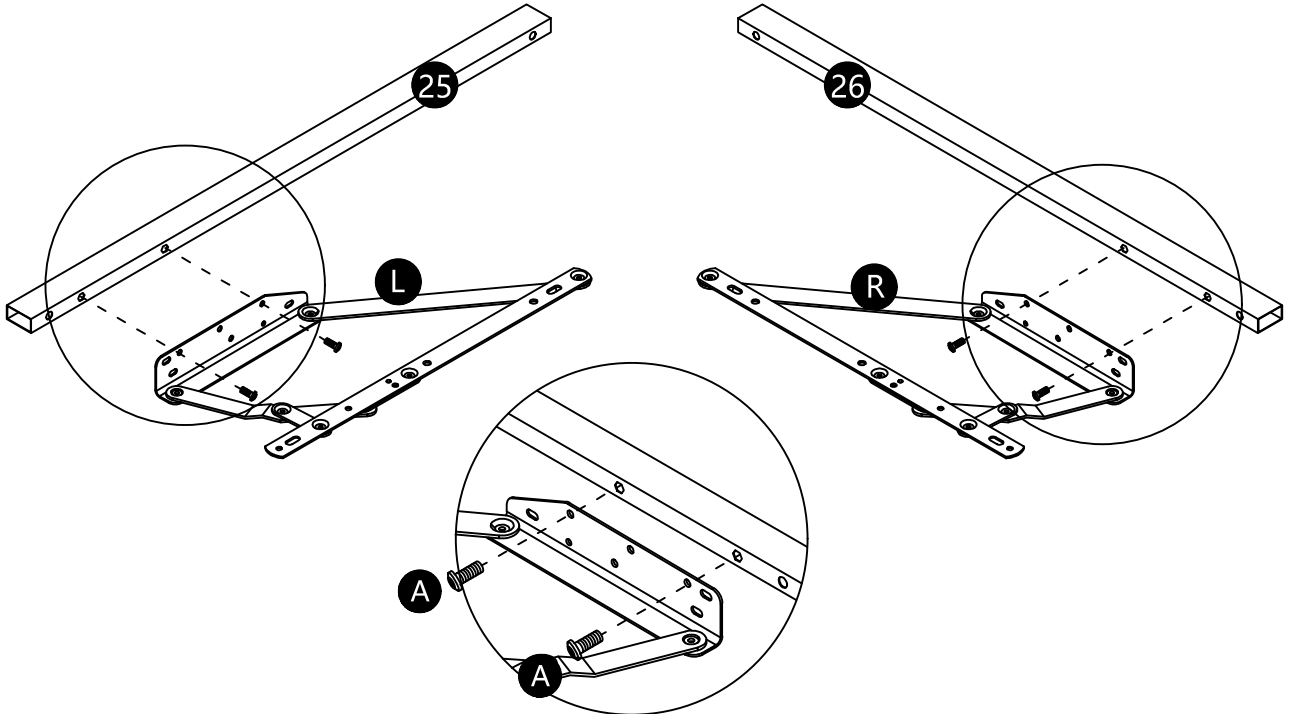

# 17

M5\*40  
HX4pcs

M6  
LX1pc

M5  
JX4pcs

M5  
NX1pc

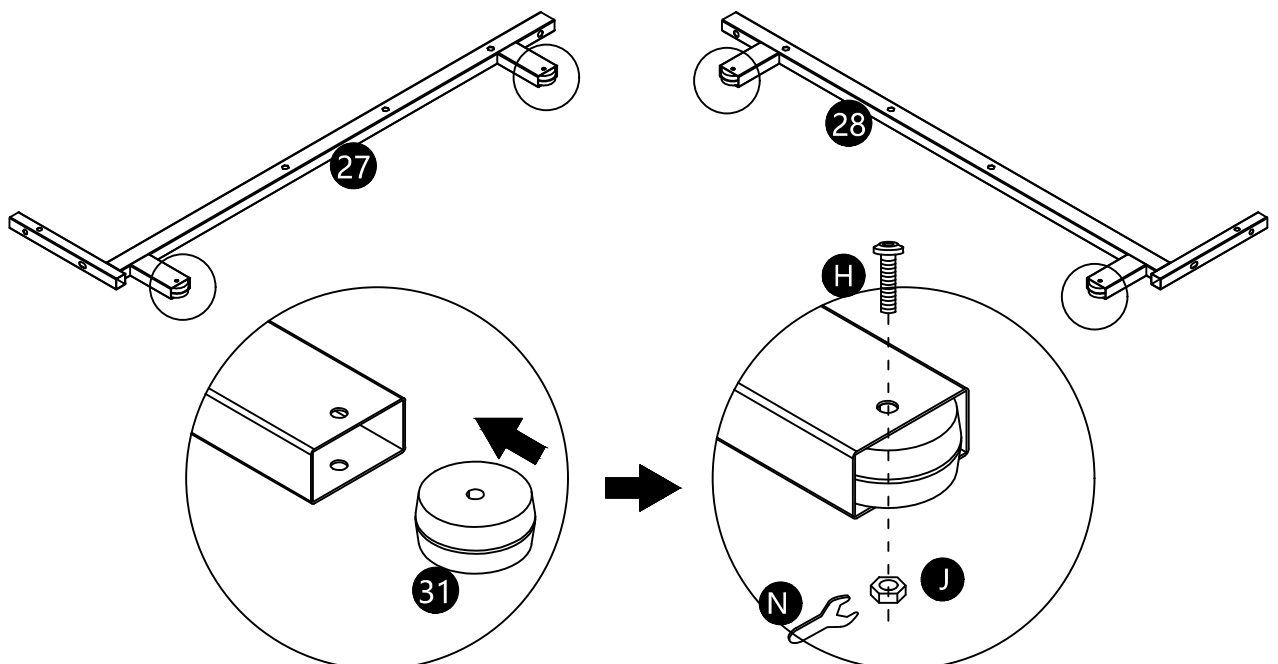

# 18

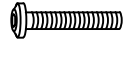

M5\*40  
HX2pcs



M6  
LX1pc



M5  
JX2pcs



M5  
NX1pc

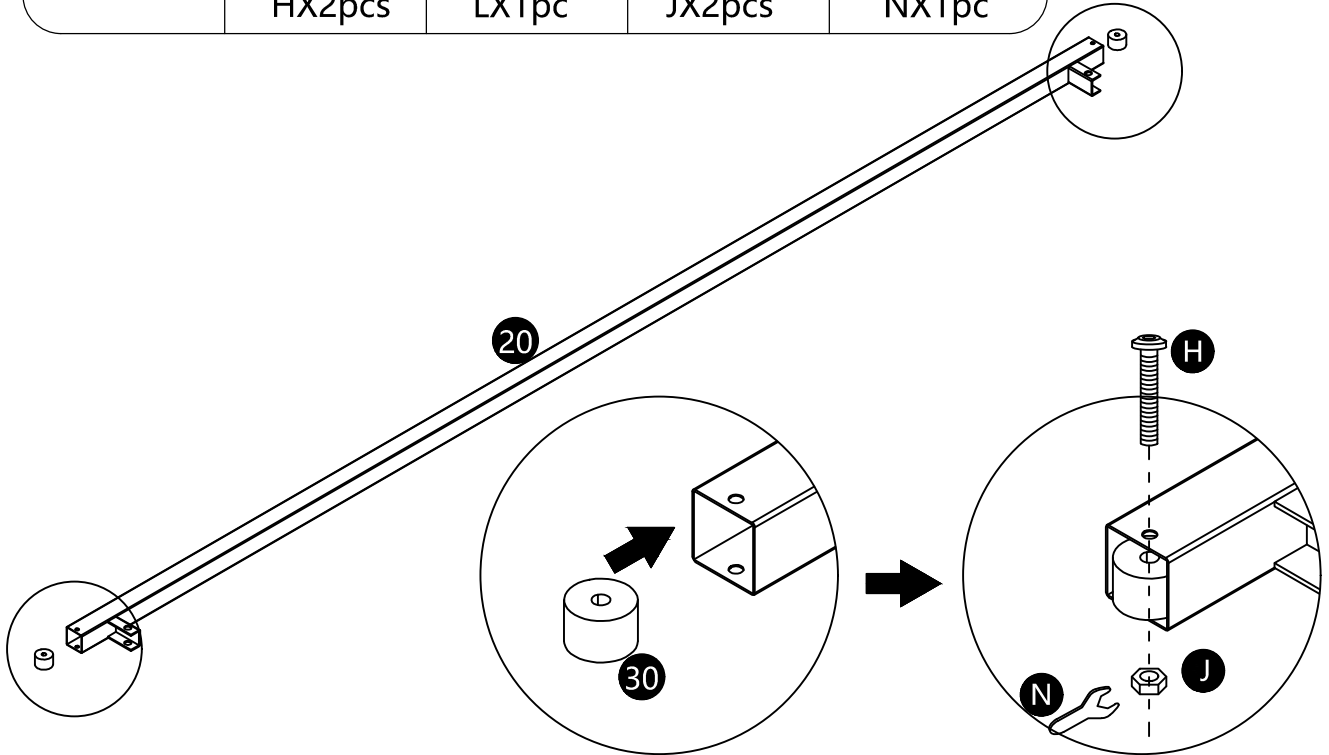

# 19



M6\*25  
CX2pcs



M6\*20  
BX2pcs



M6  
LX2pcs

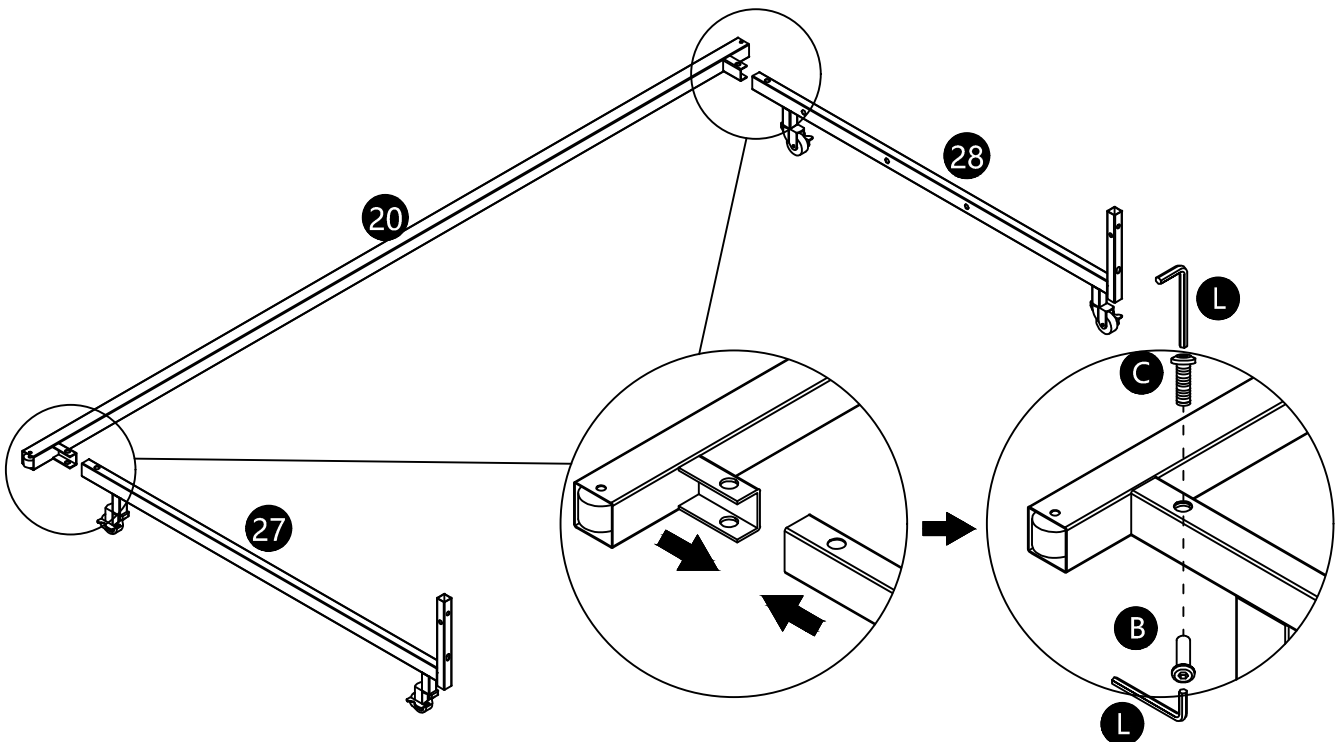

# 20

M6\*40  
EX3pcs

M6  
LX1pc

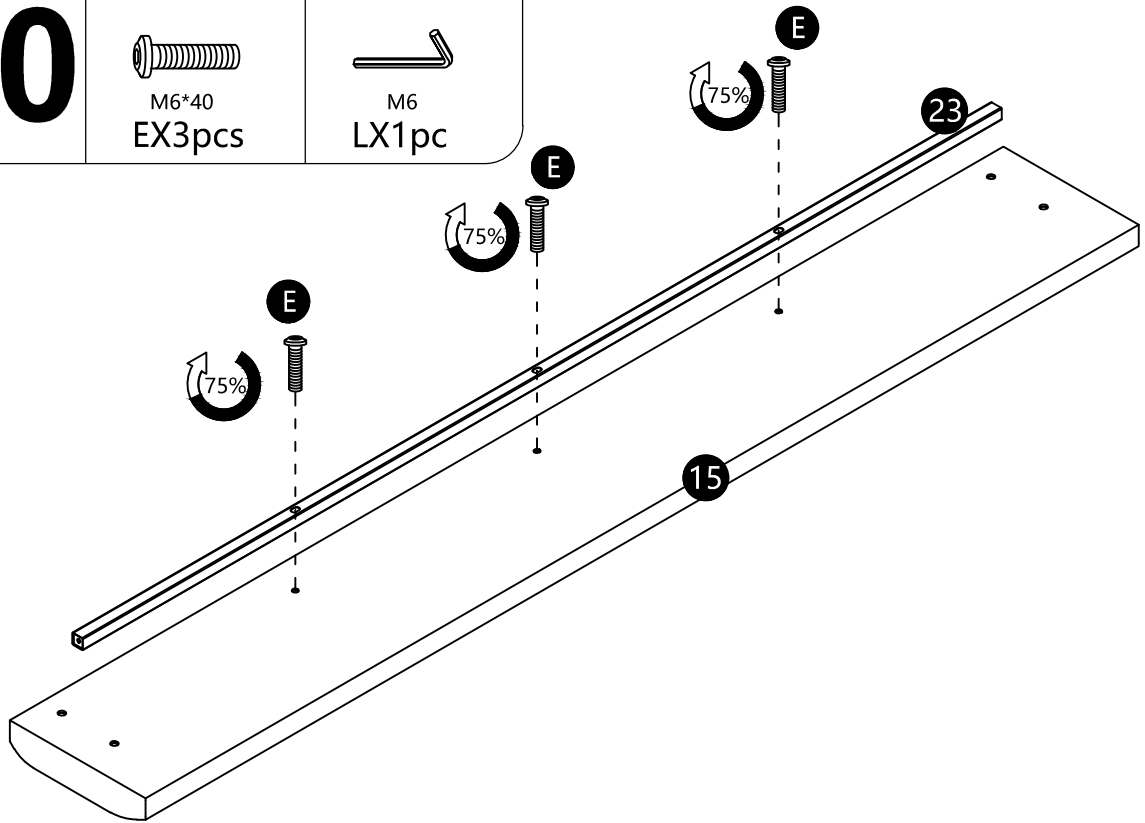

# 21

M6\*40  
EX4pcs

M6  
LX1pc

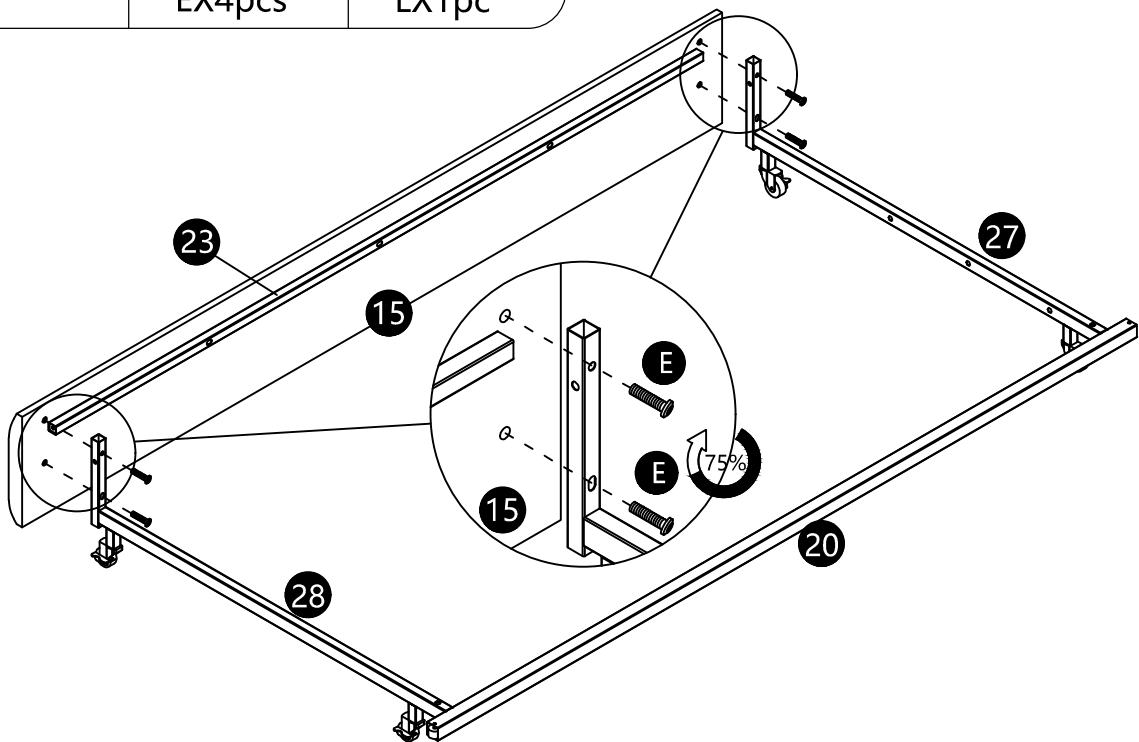

# 22



M6\*40  
EX2pcs



M6  
LX1pc

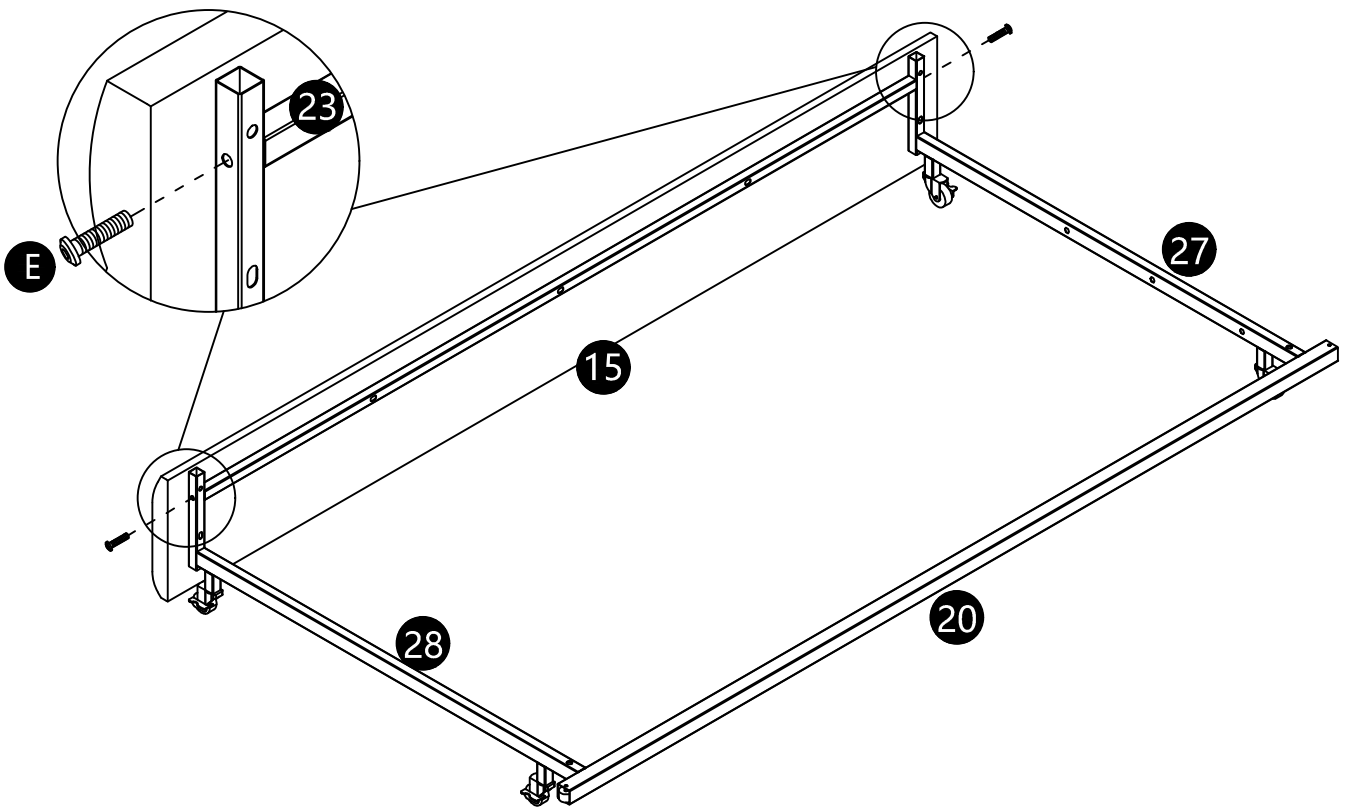

# 23



M6\*20  
AX6pcs



M6  
LX1pc

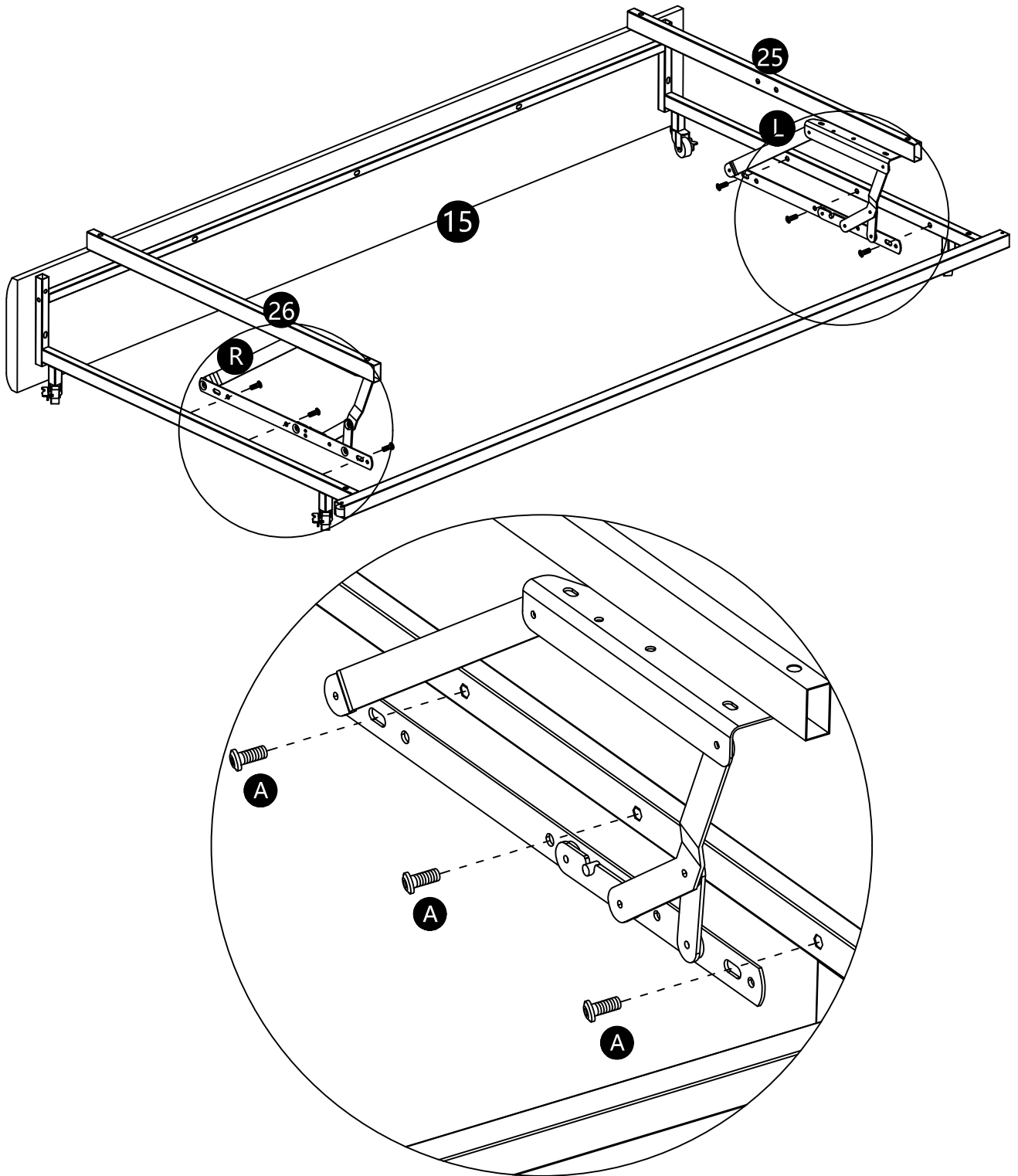

# 24



M6\*35  
DX2pcs



M6\*20  
BX2pcs



M6  
LX2pcs

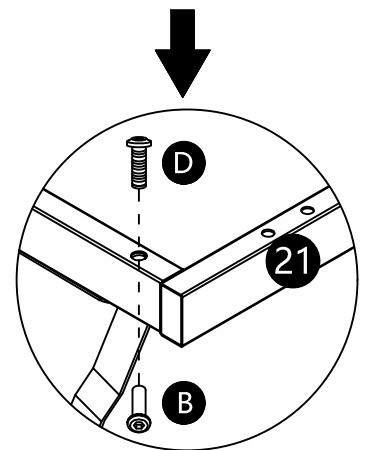
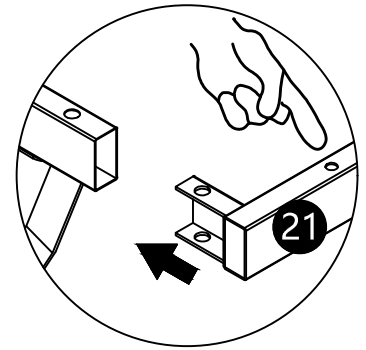
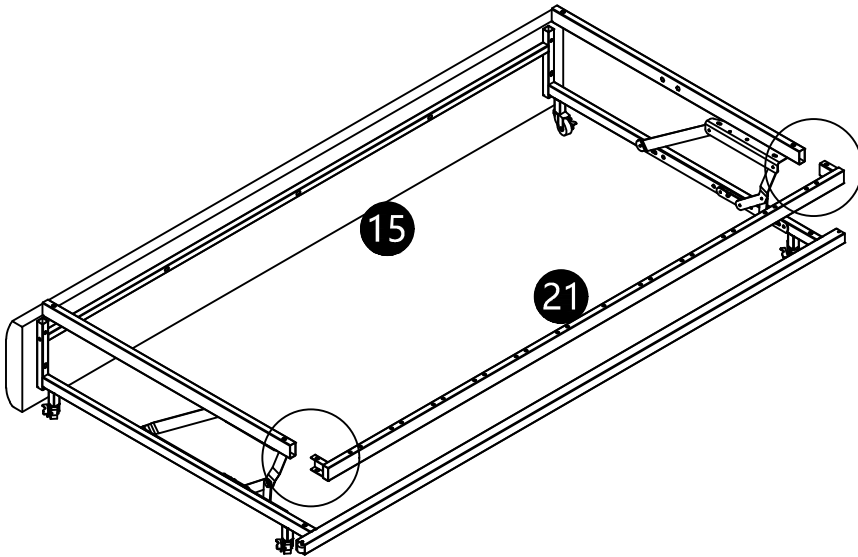

# 25



M8\*35  
GX4pcs



M8  
MX1pc

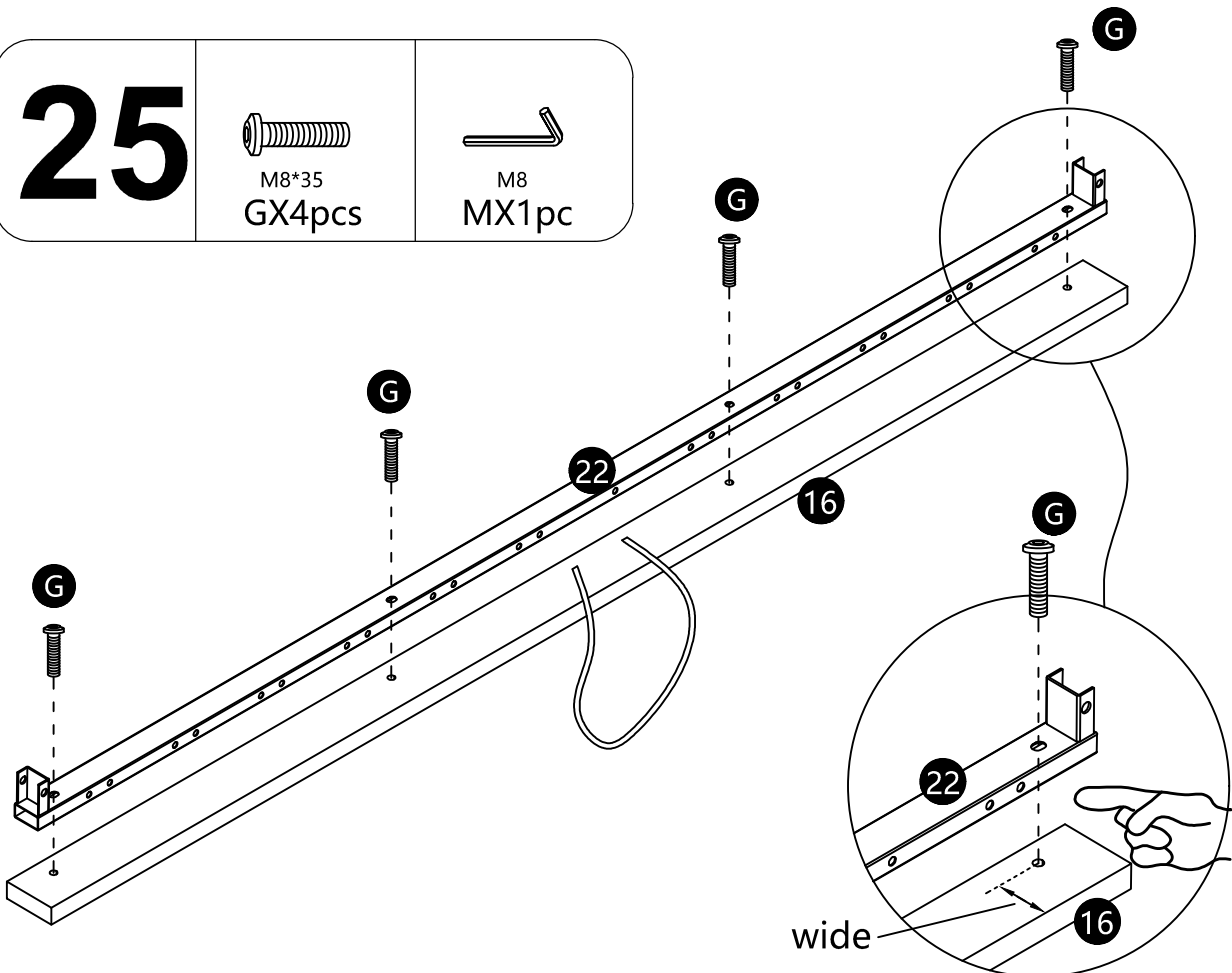

# 26



M6\*35  
DX2pcs



M6\*20  
BX2pcs



M6  
LX2pcs

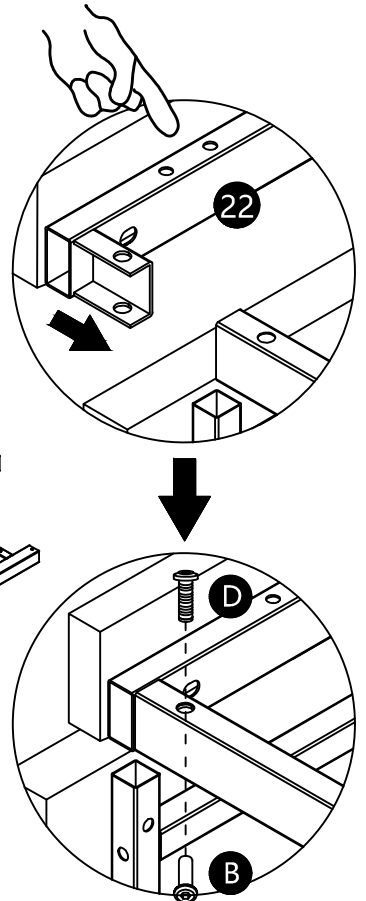
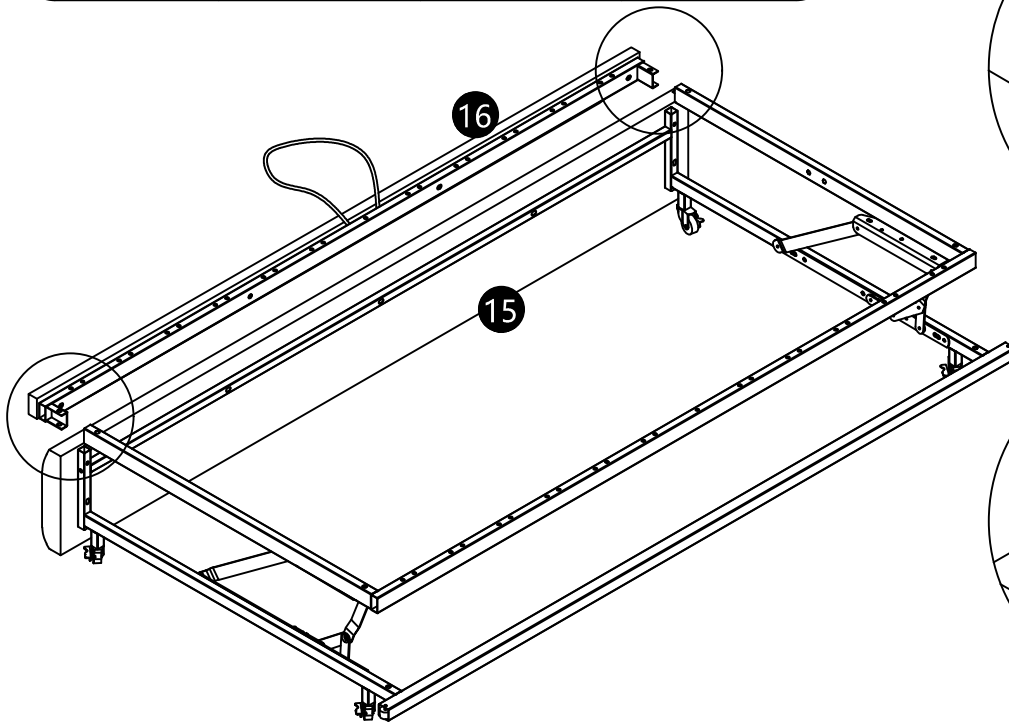

# 27



M8X20  
FX4pcs



M8  
MX1pc

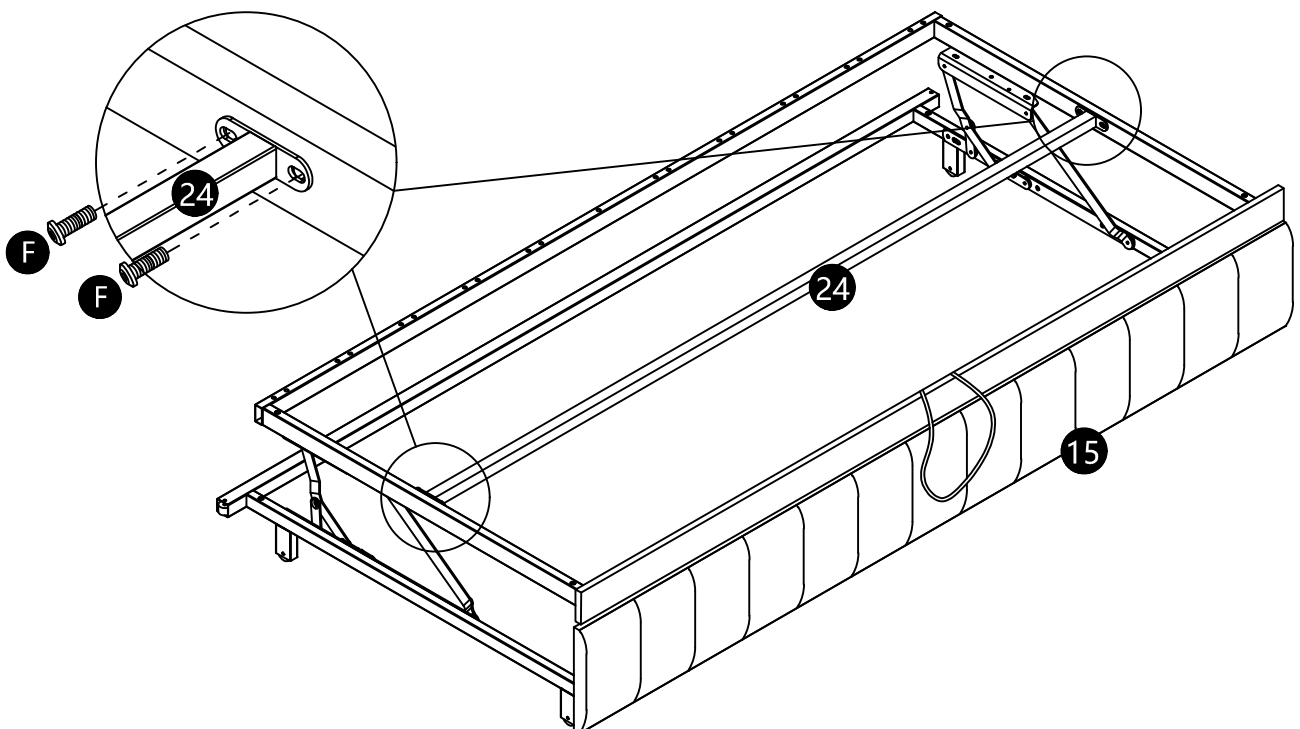

# 28



M6\*25  
CX2pcs



M6  
LX1pc

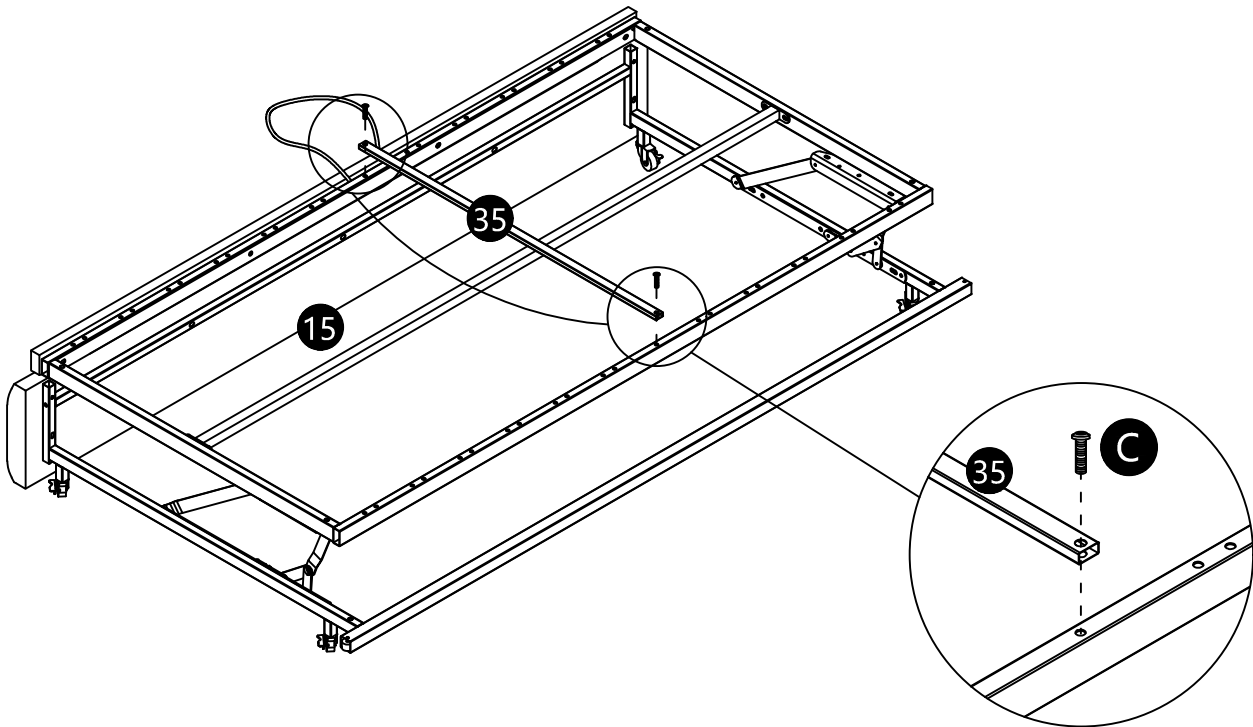

# 29

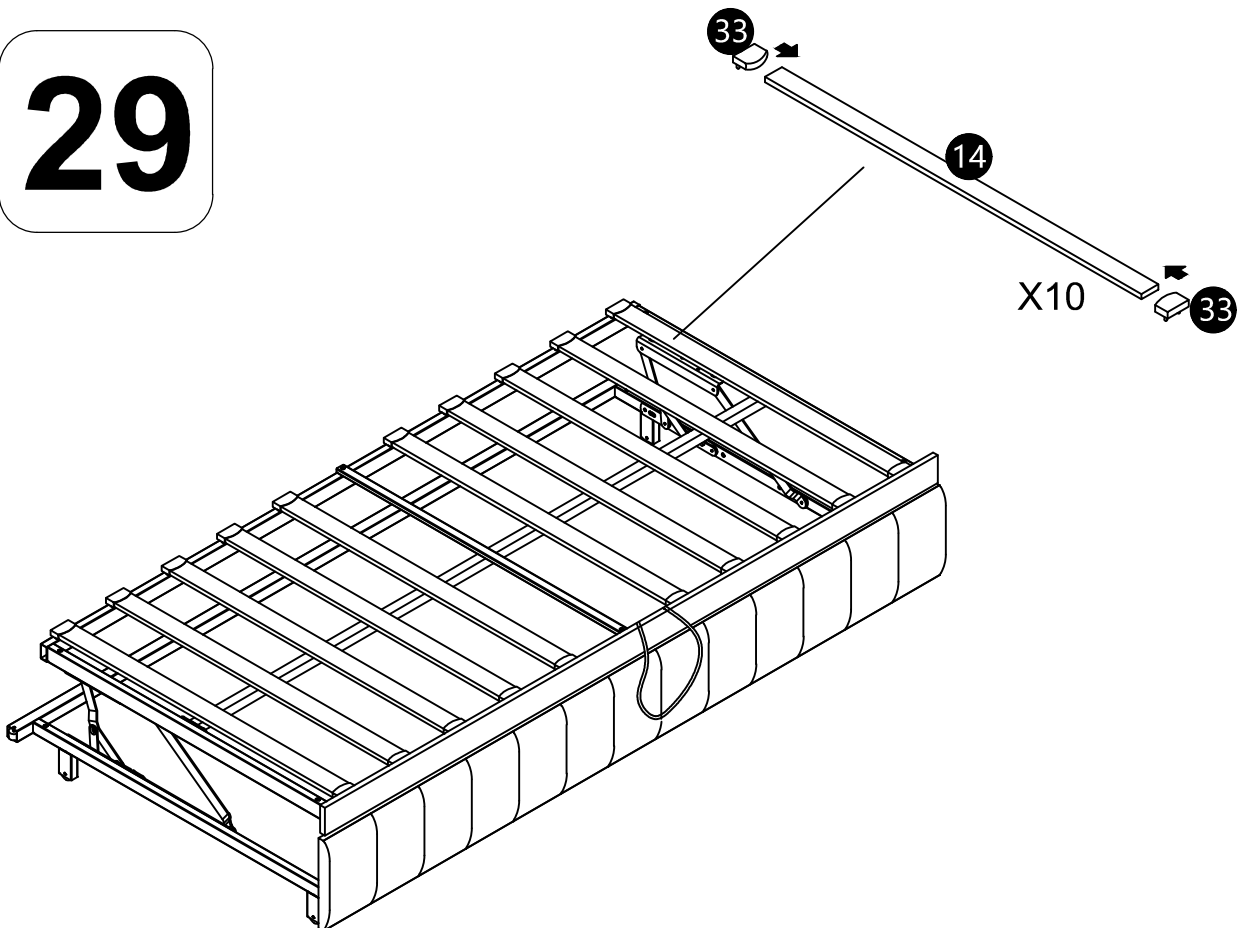

30

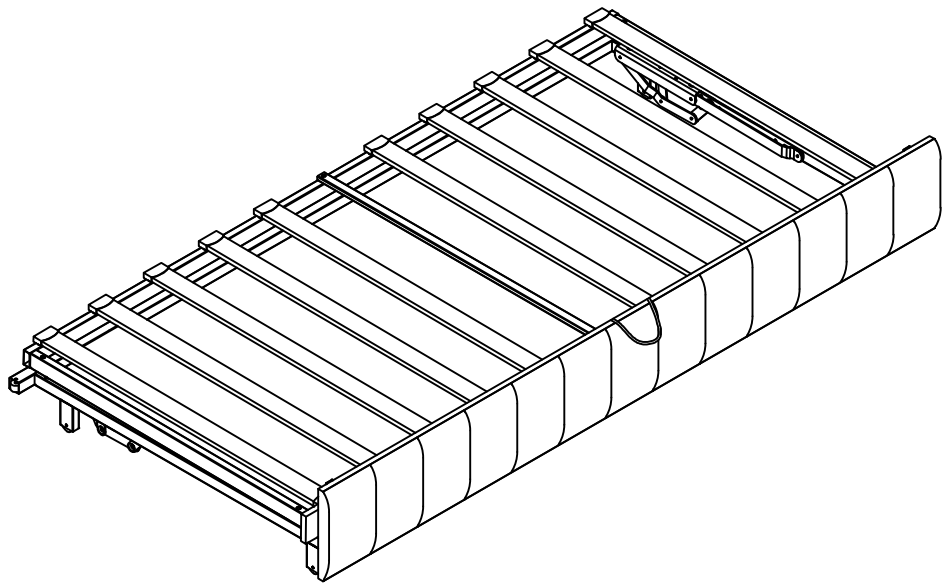
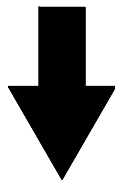
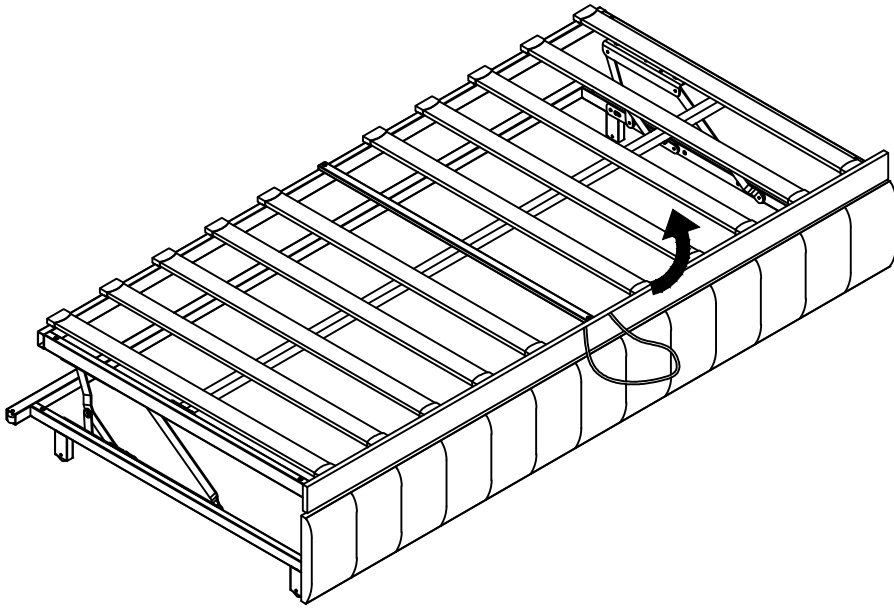

31

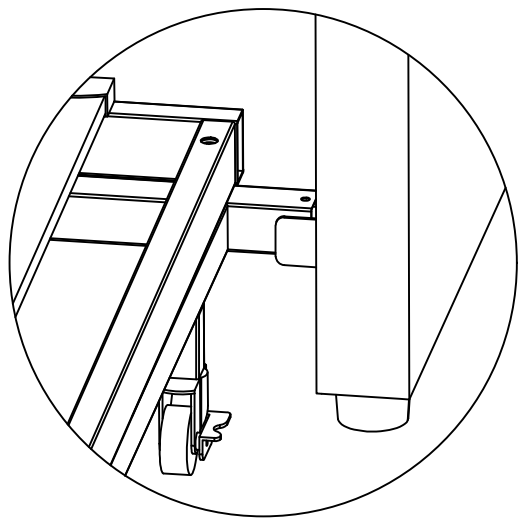
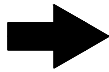
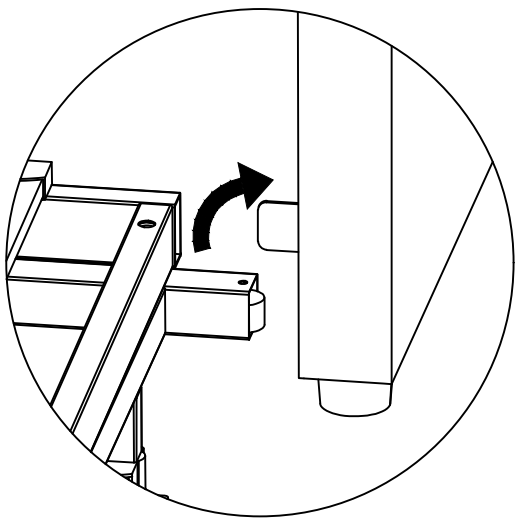
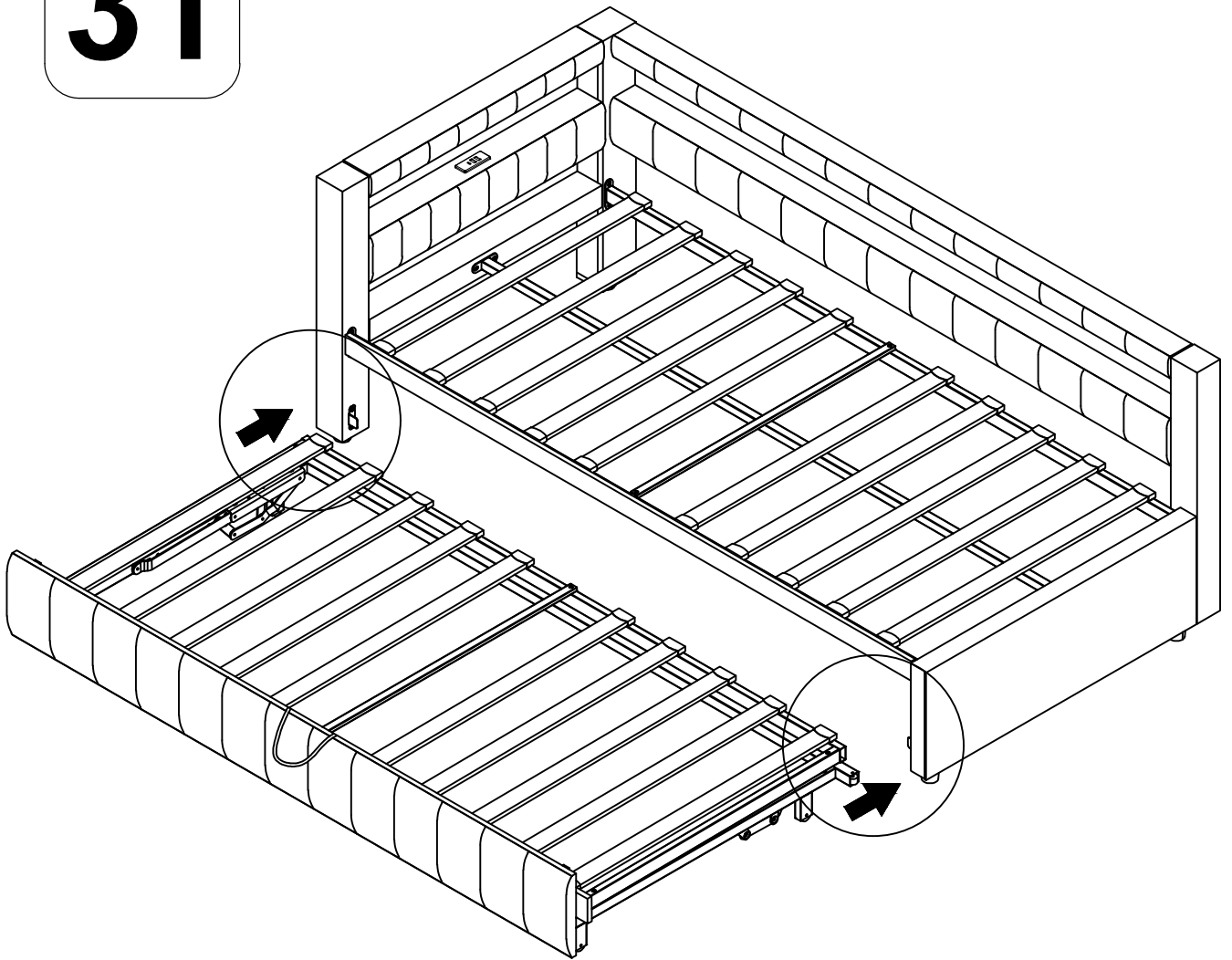

32

