

Notice de montage  
Assembling instructions  
Montageanleitung

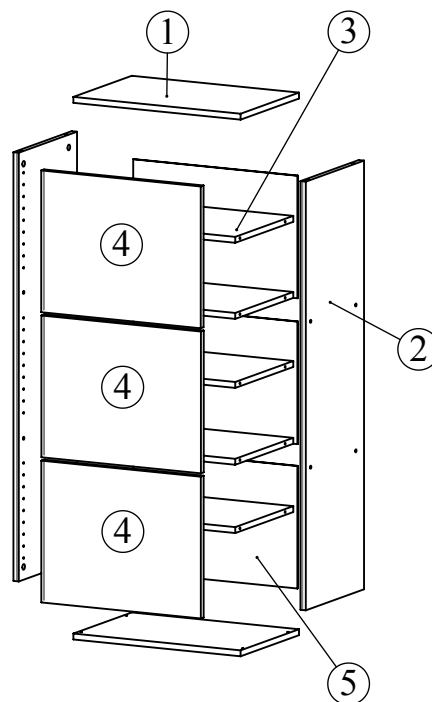
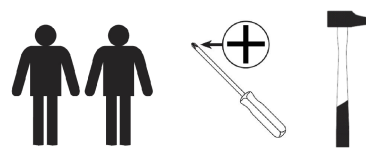

1187 x 500 x 350

N° Pièce/Part/Teile

N° Pièce	Qte	Dimensions
1	2	500 x 331 x 16
2	2	1155 x 330 x 16
3	5	467 x 329 x 16
4	3	477 x 382 x 16
5	3	491 x 330 x 3

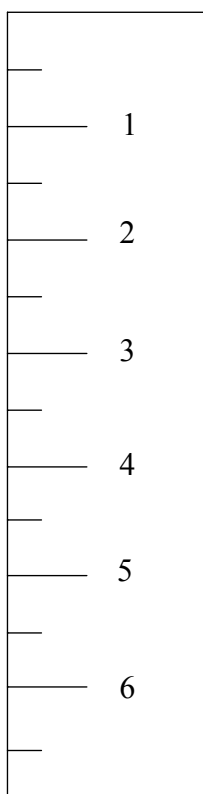
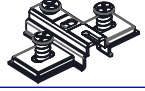

Table de nomenclature		
N° Pièce	Qte	Image
AA	8	
BA	8	
CA	8	6.3 x 50
KL	6	
KB	6	
RK	4	
DB	12	
NK	21	
ND	2	
IJ	2	4 x 15
EDB	8	
Clef	1	

1

AA  x8

BA  x8

KL  x6

KB  x6

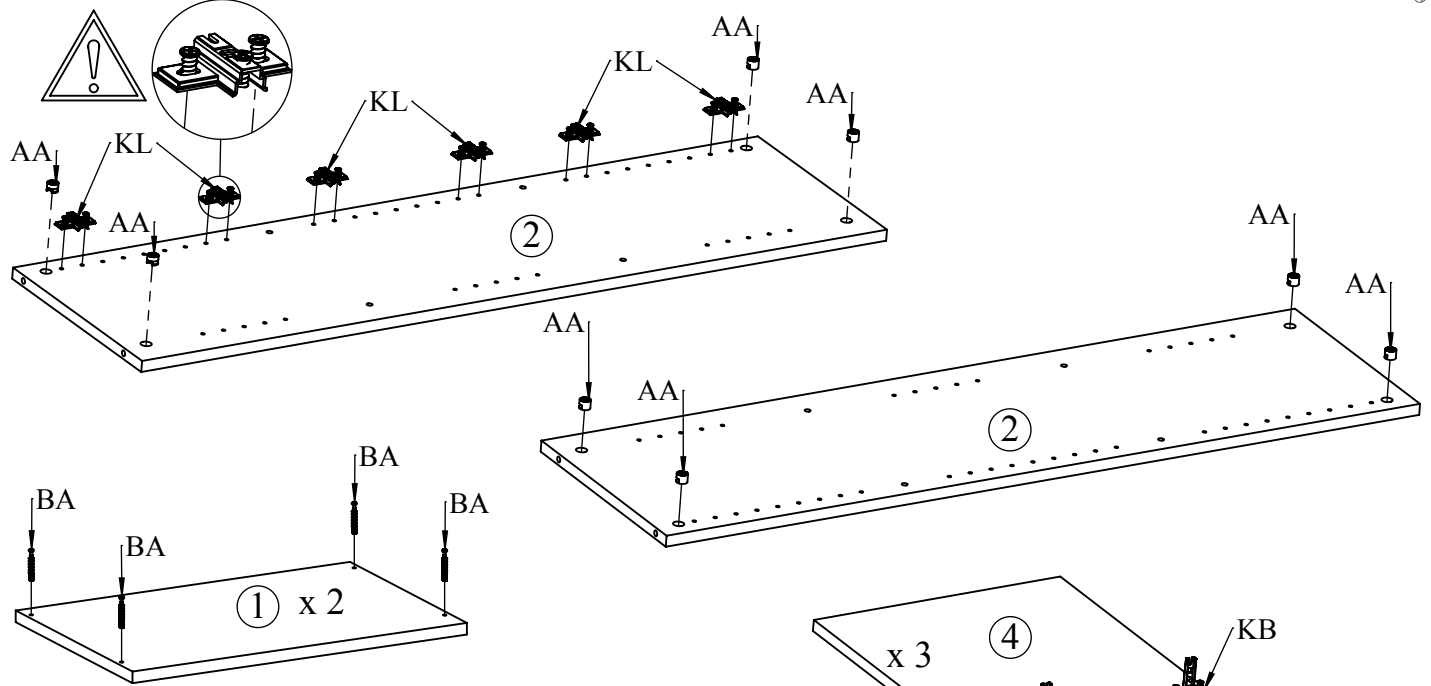
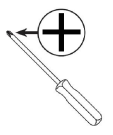

2

CA  x8

EDB  x8

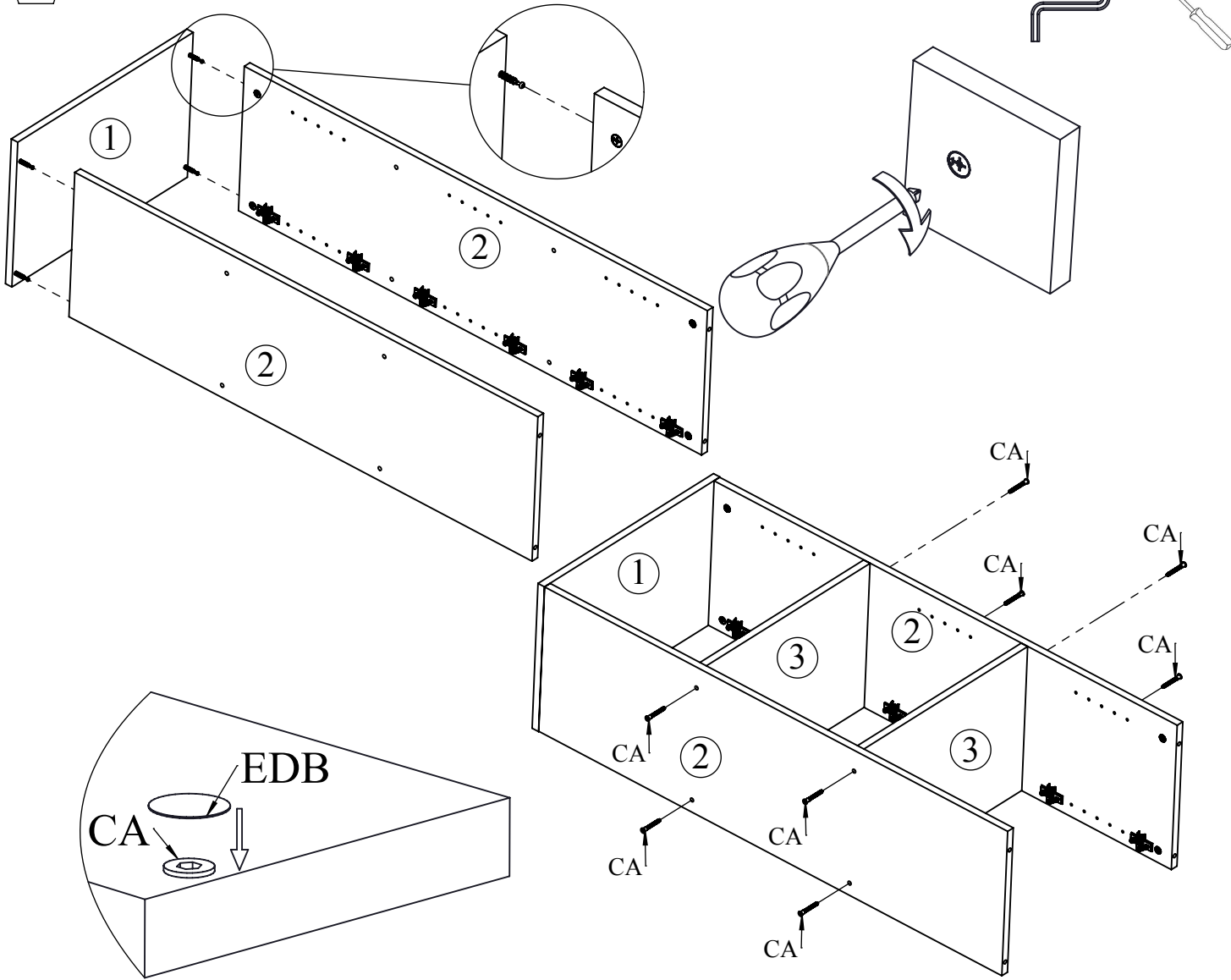
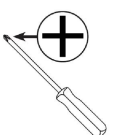

3

RK



x4

NK



x21

NK

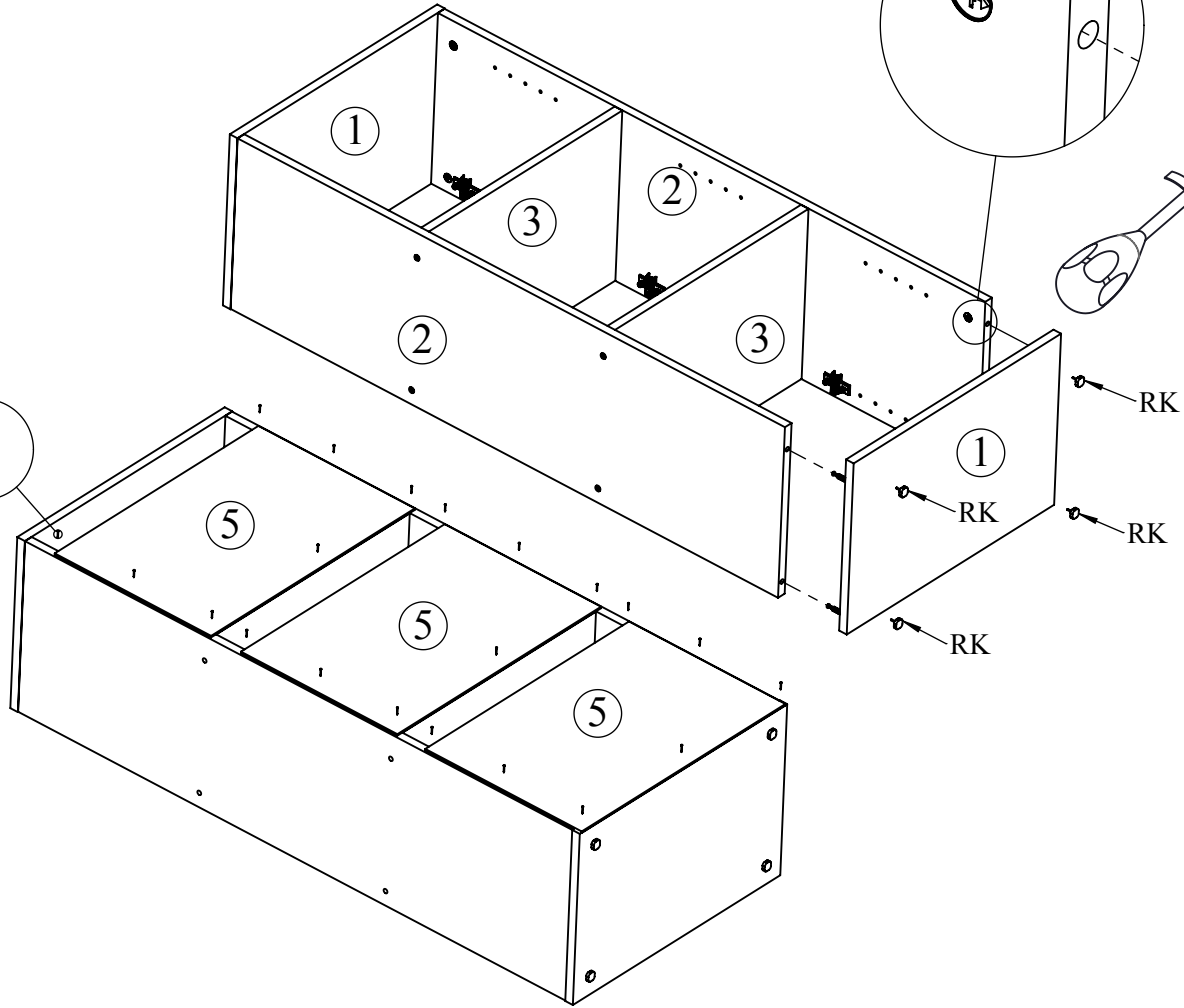
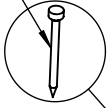

4

DB



x12

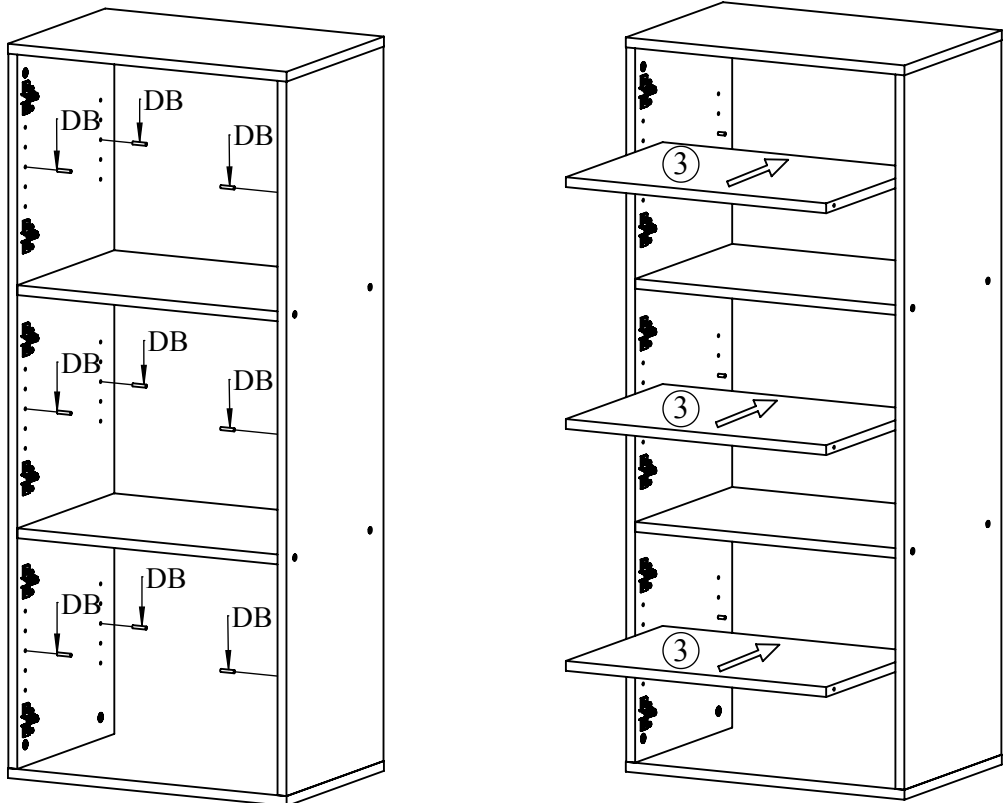

5

ND

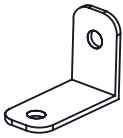

x2

IJ



x2

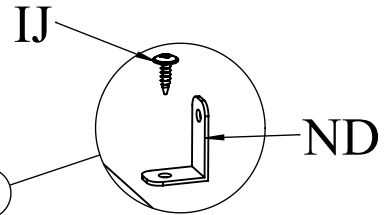
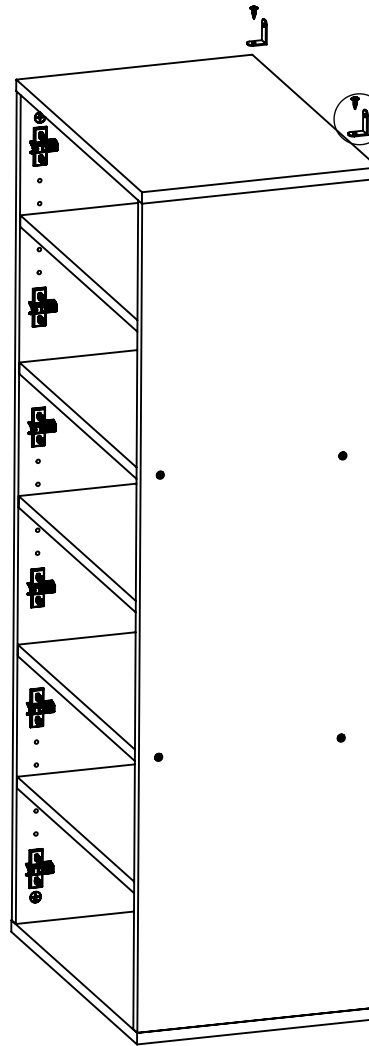
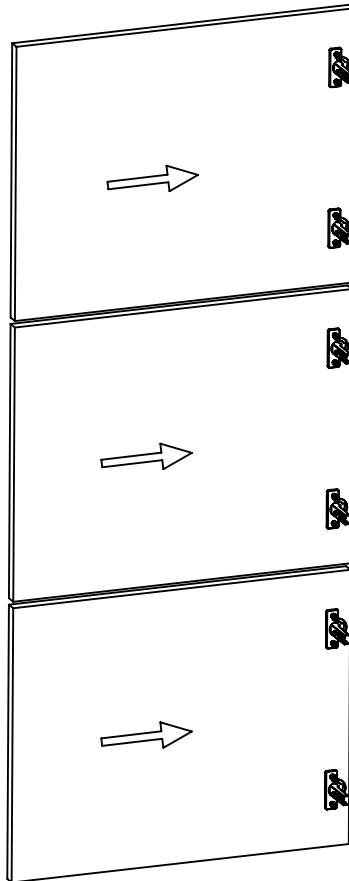
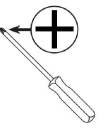

**FR.** Fixation murale impérative par une personne compétente avec vis et chevilles adaptées à la nature du mur.

**EN.** Unit must be secured to the wall by a competent person with appropriate screws and plugs

**DE.** Die Wandbefestigung muss von Fachmann und mit den dazu passenden Material montiert werden.

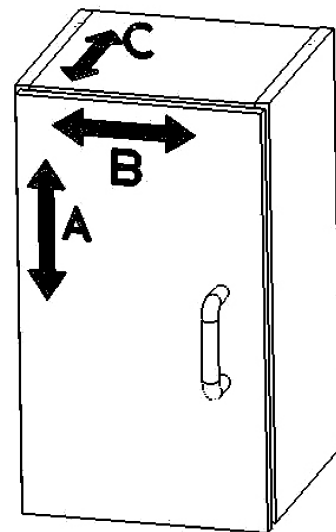
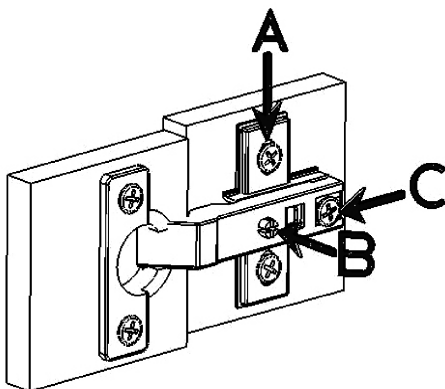
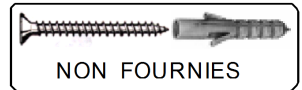

#### INSTRUCTIONS D'ENTRETIEN

Laver les surfaces à l'aide d'un chiffon doux, préalablement trempé dans une solution savonneuse (max. 1%)  
**ATTENTION!** Ne pas utiliser de produit contenant de l'alcool ou de l'abrasif.  
 Essuyer à l'aide d'un chiffon doux.

#### CARE AND CLEANING INSTRUCTIONS

Wash the surfaces with a soft cloth damped in a mild soap solution (max 1%).  
**NOTE!** Do not use cleaners containing alcohol or abrasives.  
 Wipe the surface dry with a soft cloth.

#### PFLEGEHINWEIS

Zur Reinigung und Pflege verwenden sie, ein feuchter Lappen mit Seifenlauge (max 1%) zum Abwischen  
**WICHTIG!** Keine alkoholhaltigen Mittel oder Schleifmittel verwenden.  
 Die Oberfläche mit einem weichen Tuch abtrocknen.