

CARE AND MAINTENANCE

Do not use acids or alkaline cleaning agents. Sharp objects will damage (scratch) the surface. Wipe the surface with a soft cloth (not too wet).



NOTICE

*Please make sure that you have all parts indicated before you begin assembly of this item

* This item should be assembled on a soft surface to prevent scratching the finish during assembly

* This item may require periodic tightening

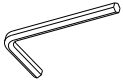
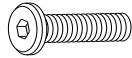
Part List and Hardware List

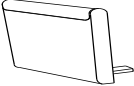
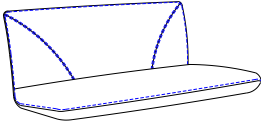
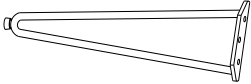
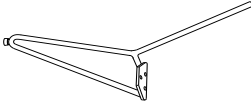
PIECE	DESCRIPTION	PICTURE	QUANTITY
A	Allen Key		1×
B	Screw		20×
C	Lock Washer		20×
D	Screw Washer		20×
E	Arm Rest		2×
F	Seat Panel		1×
G	Front Leg		2×
H	Back Leg		2×

PRODUCT DIMENSIONS: 51.97"W × 28.35"D × 32.68"H

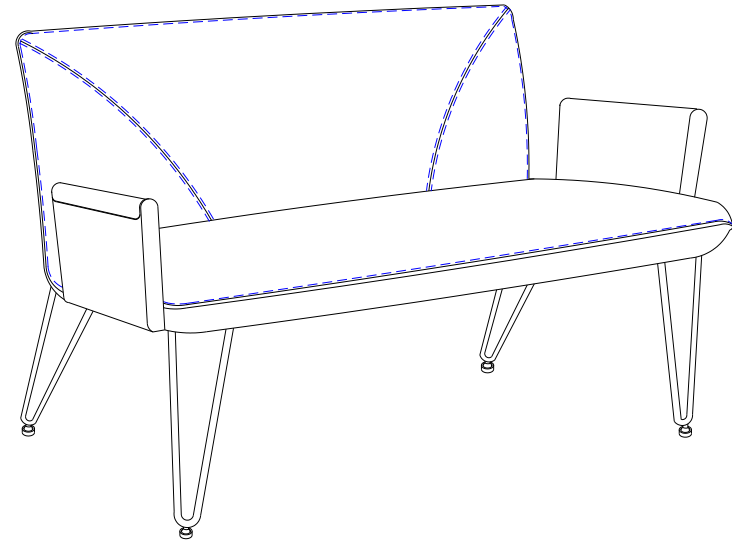

PREPARATION

Before beginning assembly of product, make sure all parts are present. Compare parts with package contents list and hardware contents list

If any part is missing or damaged, do not attempt to assemble the product,

Estimated Assembly Time: 10 Minutes

Tools Required for Assembly(Included): Allen Key

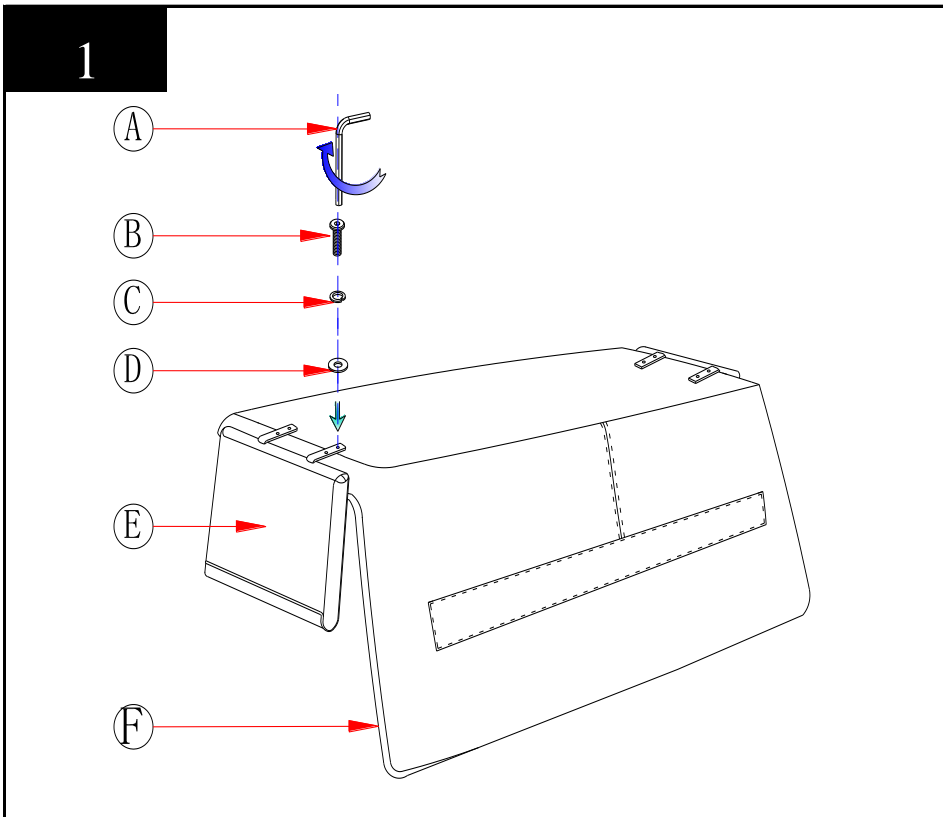

Step 1

Attach the arm rest(E) to seat panel(F), using hardware (B)(C)(D) tighten with allen key(A)

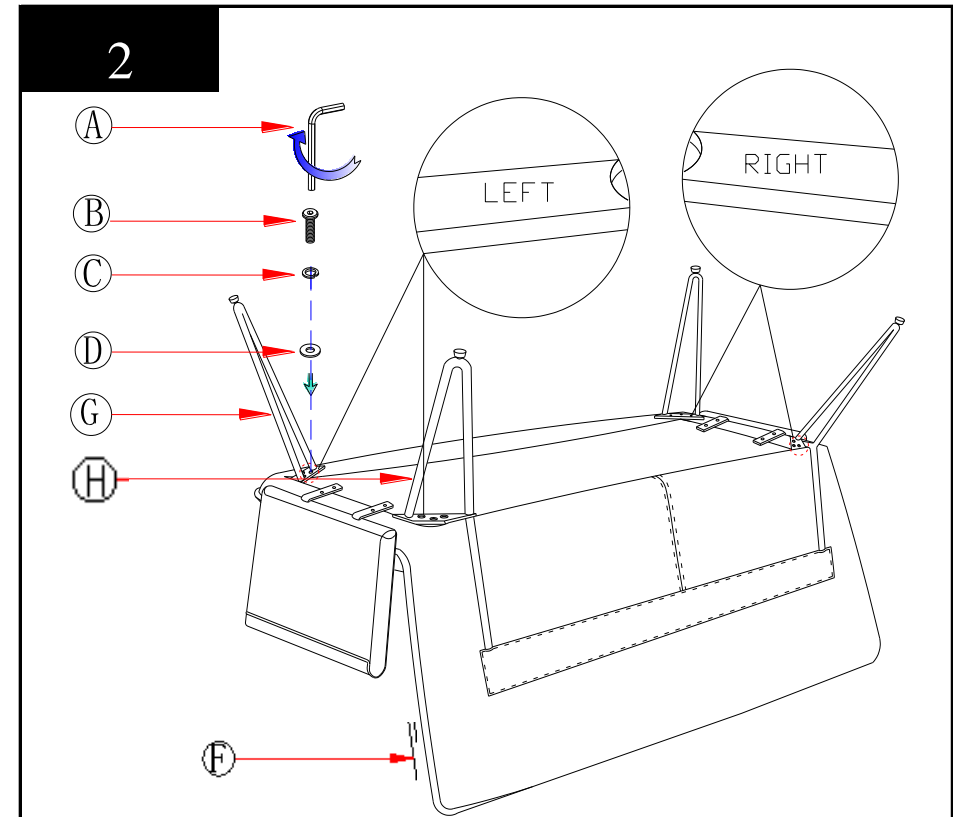

Step 2

Ensure the arm rest installed tightly, Then attach two front legs(G), two back legs(H)to seat panel(F), using hardware(B)(C) (D)tighten with Allen key(A).See picture above.

3

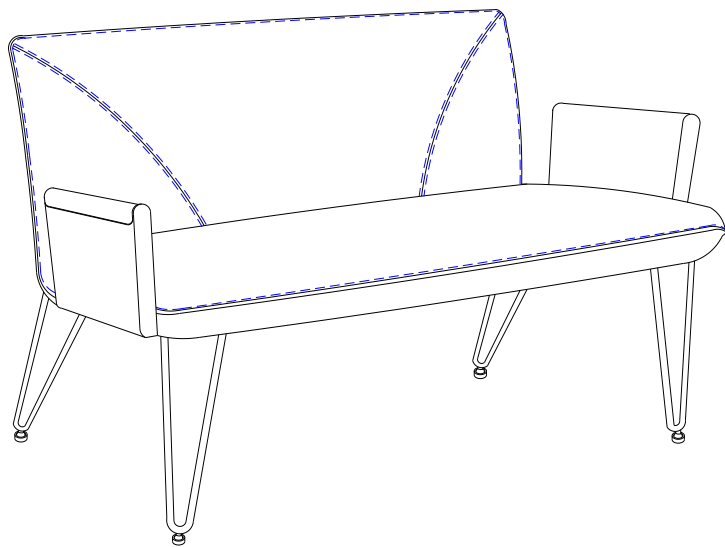

Step 3

Turn over the products. The assembly is finished.