

INSTALLATION

Product Manual

Description du produit

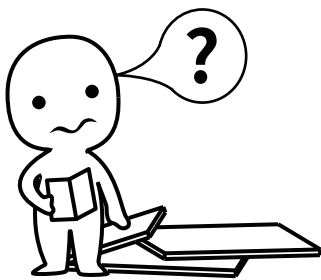

IMPORTANT INFORMATION!

please read the entire manual before starting to assemble and/or using this product. follow the manual thoroughly and keep it for further reference.

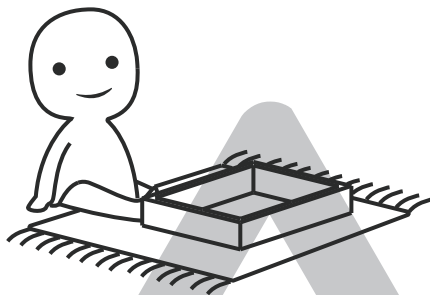
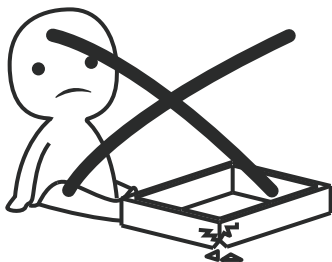

AVOID SCRATCHES!

In order to avoid scratching this furniture should be assembled on a soft layer- could be a rug.

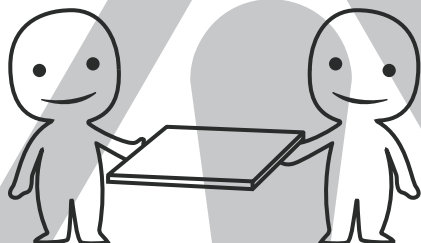

IMPROVE EFFICIENCY !

Try to find a partner to install with you, which can speed up the installation efficiency and shorten the time.

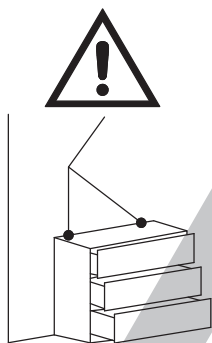

ANTI-TOPPLE WARNING !

Overturnd furniture can cause serious or fatal crush injuries. To prevent tipping over, be sure to use the wall attachment, if not included with this product. Please purchase the wall attachment that fit your wall. If unsure, seek professional advice. Please read and follow each step of the instructions carefully.

IMPORTANT !

It is important that any product which is assembled using any kind of screw is re-tightened 2 weeks after assembly, and once every 3 months - in order to assure stability through-out the lifespan of the product.

For regular maintenance and cleaning of the product, for the frame, please use a rag dipped in neutral detergent to fully wipe it, and then dry it with a clean rag. For glass materials, wipe with a rag dampened with water glass cleaner, and then dry with a dry rag.

Do not use an electric screwdriver, and do not use too much force when installing, because the board is easy to break.

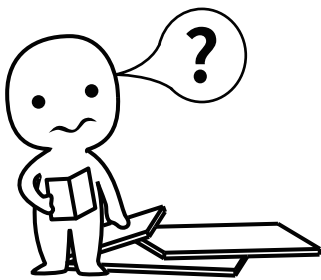

AVERTISSEMENT!

Veillez lire le manuel en entier avant de commencer à assembler et/ou à utiliser ce produit. Suivez attentivement le manuel et conservez-le pour référence ultérieure.

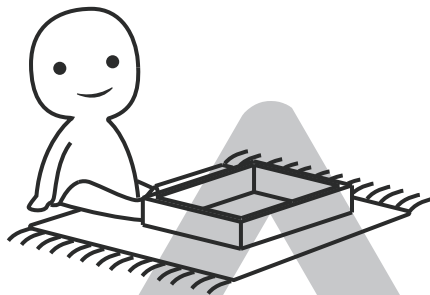
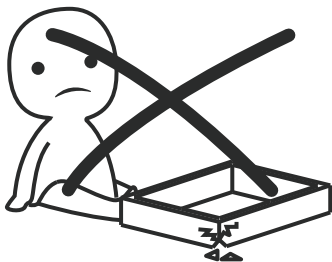

ÉVITEZ LES RAYURES!

Afin d'éviter de rayer ce meuble doit être assemblé sur une couche souple - pourrait être un tapis.

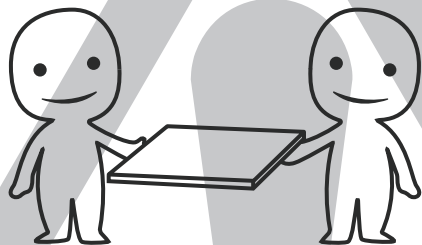

AMÉLIORER L'EFFICACITÉ !

Essayez de trouver un partenaire à installer avec vous, ce qui peut accélérer l'efficacité de l'installation et raccourcir le temps.

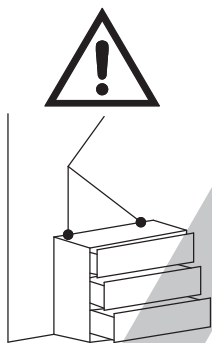

AVERTISSEMENT ANTI-RENVERSEMENT !

Les meubles renversés peuvent causer des blessures graves ou mortelles par écrasement. Pour éviter de basculer, assurez-vous d'utiliser la fixation murale, si elle n'est pas incluse avec le produit. Veillez acheter la fixation murale qui s'adapte à votre mur. En cas de doute, demandez conseil à un professionnel. Veillez lire et suivre attentivement chaque étape des instructions.

IMPORTANT !

Il est important que tout produit assemblé à l'aide de tout type de vis soit resserré 2 semaines après l'assemblage et une fois tous les 3 mois, afin d'assurer la stabilité tout au long de la durée de vie du produit.

Pour l'entretien régulier et le nettoyage du produit, pour le cadre, veuillez utiliser un chiffon trempé dans un détergent neutre pour l'essuyer complètement, puis séchez-le avec un chiffon propre. Pour les matériaux en verre, essuyez avec un chiffon imbibé d'eau nettoyant pour vitres, puis séchez avec un chiffon sec.

N'utilisez pas de tournevis électrique et n'utilisez pas trop de force lors de l'installation, car la carte est facile à casser.

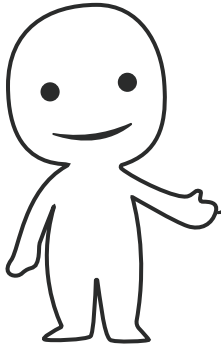

Please prepare the following tools
Veuillez préparer les outils suivants

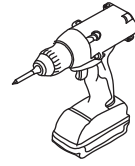
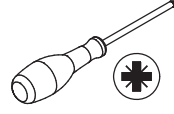
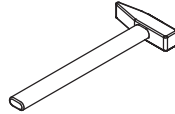
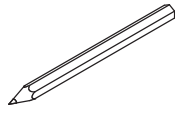

When installing, please carefully confirm whether each screw corresponds to the manual, accessories with similar shapes can be distinguished by size
Lors de l'installation, veuillez vérifier soigneusement si chaque vis correspond au manuel. Les accessoires de forme similaire peuvent être distingués par leur taille.

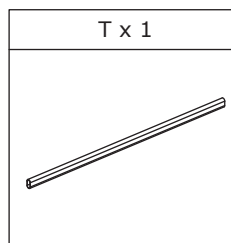
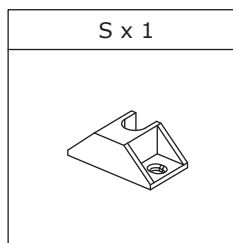
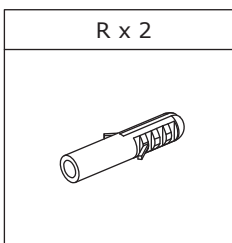
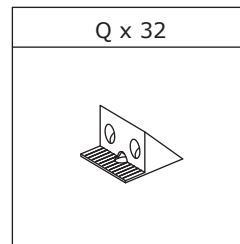
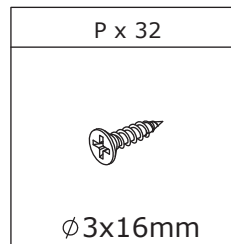
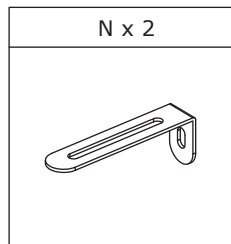
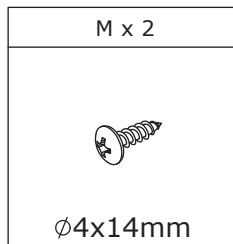
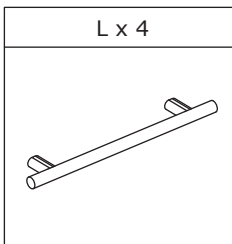
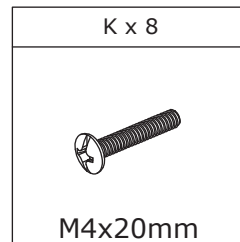
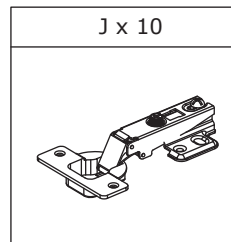
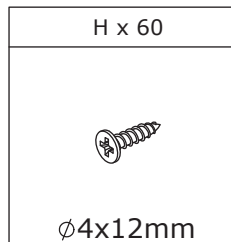
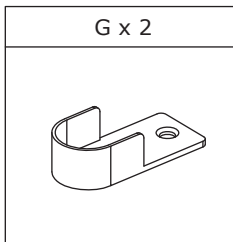
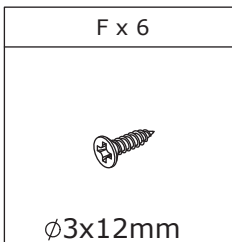
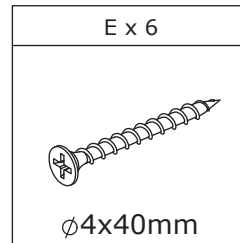
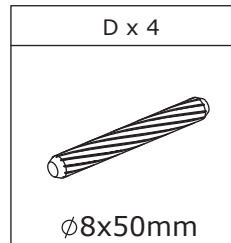
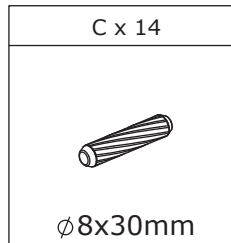
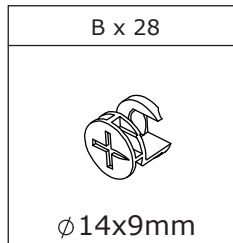
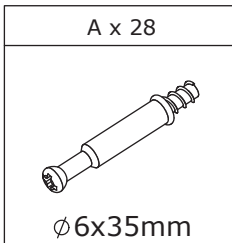

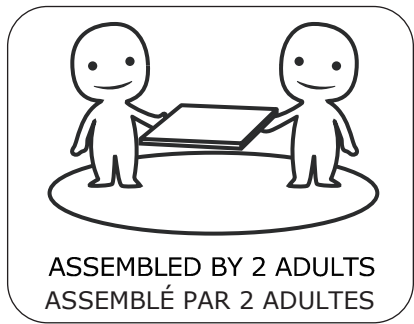
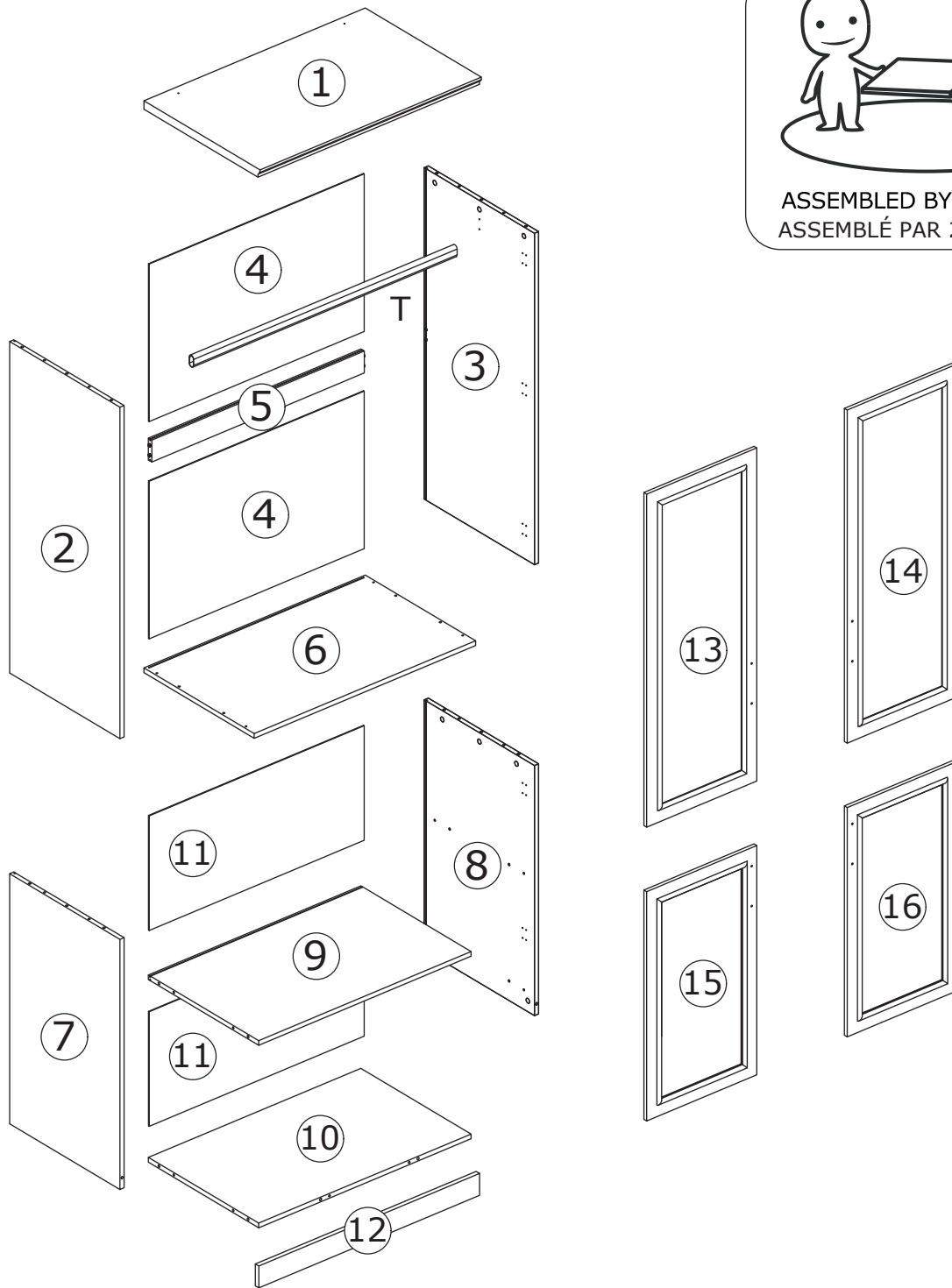

⚠ WARNING

Children have died from furniture tipover. To reduce the risk of furniture tipover:

- ALWAYS install Anti-tip device provided.
- NEVER put a TV on this product.
- NEVER allow children to stand, climb or hang on drawers, doors, or shelves.
- NEVER open more than one drawer at a time.
- Place heaviest items in the lowest drawers.





This is a permanent label. Do not remove!

⚠ AVERTISSEMENT

Des enfants sont morts à la suite du renversement d'un meuble. Pour réduire le risque de basculement du meuble :

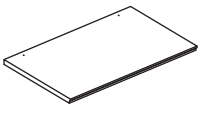
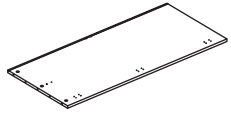
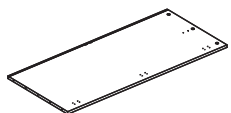
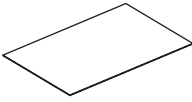
- TOUJOURS installer le dispositif anti-basculement fourni.
- N'installez jamais un téléviseur sur ce produit.
- NE jamais permettre aux enfants de se tenir debout, de grimper ou de s'accrocher aux tiroirs, aux portes ou aux étagères.
- N'ouvrez jamais plus d'un tiroir à la fois.
- Placez les objets les plus lourds dans les tiroirs les plus bas.

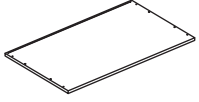
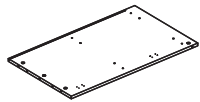
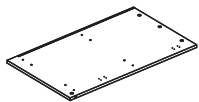
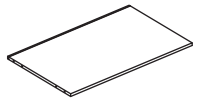
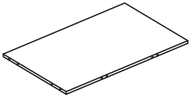
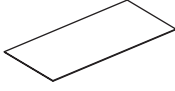
Il s'agit d'une étiquette permanente. Ne l'enlevez pas !

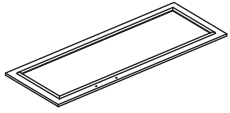
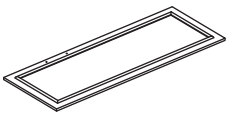
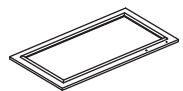
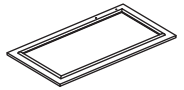
<p>①</p>  <p>1PC</p>	<p>②</p>  <p>1PC</p>	<p>③</p>  <p>1PC</p>
<p>④</p>  <p>2PCS</p>	<p>⑤</p>  <p>1PC</p>	<p>⑥</p>  <p>1PC</p>
<p>⑦</p>  <p>1PC</p>	<p>⑧</p>  <p>1PC</p>	<p>⑨</p>  <p>1PC</p>
<p>⑩</p>  <p>1PC</p>	<p>⑪</p>  <p>2PCS</p>	<p>⑫</p>  <p>1PC</p>
<p>⑬</p>  <p>1PC</p>	<p>⑭</p>  <p>1PC</p>	<p>⑮</p>  <p>1PC</p>
<p>⑯</p>  <p>1PC</p>		

1

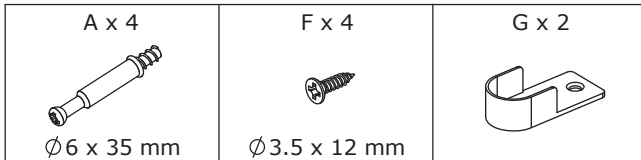

Insert quickfit screw(A) into plate 2 and 3 with a screwdriver as shown. Fix part(G) to plate 2 and 3 with screw(F) as shown.

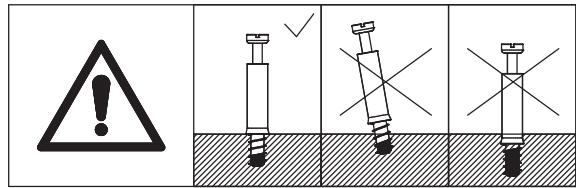

Insérez la vis à ajustement rapide (A) dans les plaques 2 et 3. avec un tournevis comme indiqué. Fixez la pièce (G) à plaques 2 et 3 avec la vis (F) comme indiqué.

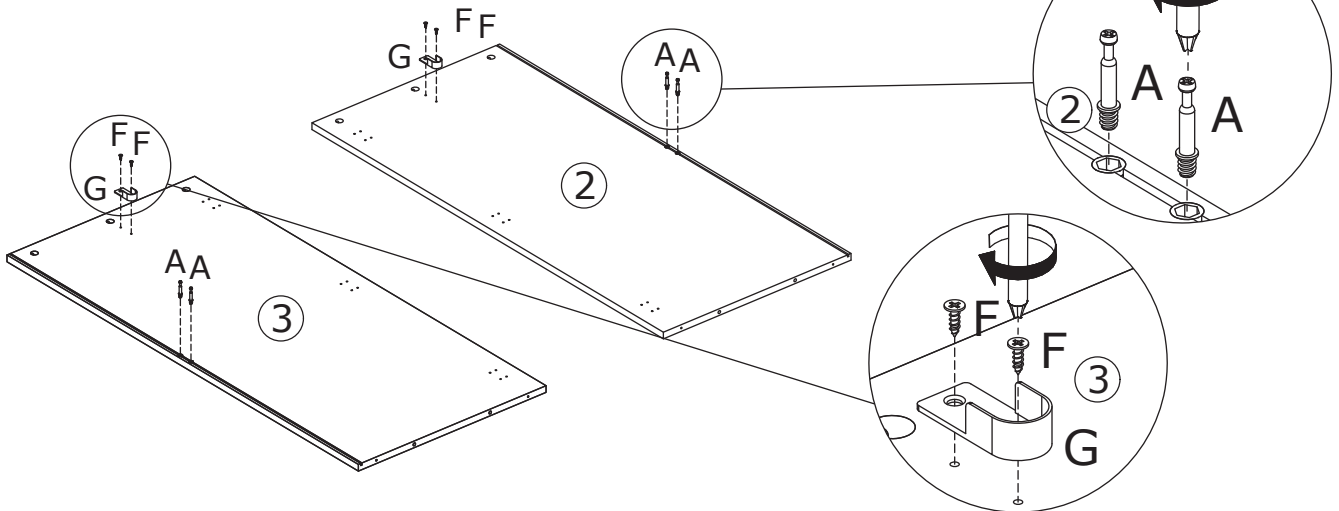

2

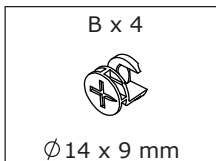

Connect plate 2 and 3 with plate 5, put cam lock(B) into plate 5 and turn clockwise to tighten as shown.

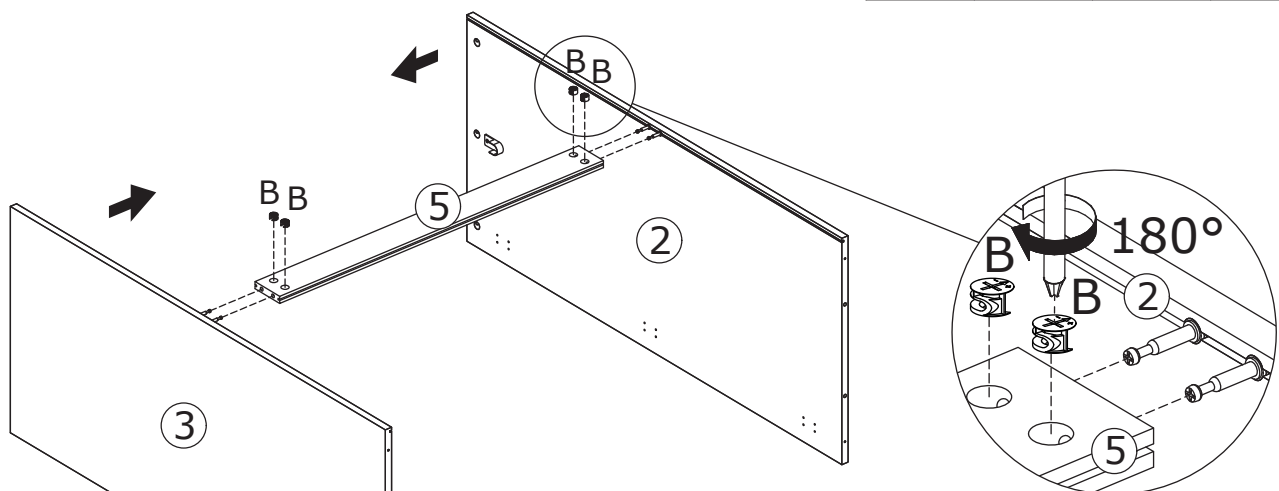
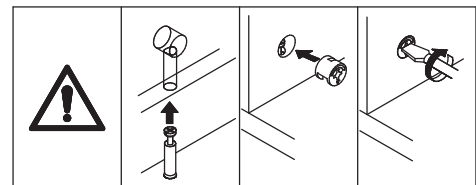

Relier les plaques 2 et 3 avec la plaque 5, placez le verrou à came (B) dans la plaque 5 et tournez dans le sens des aiguilles d'une montre pour serrer comme indiqué.

3

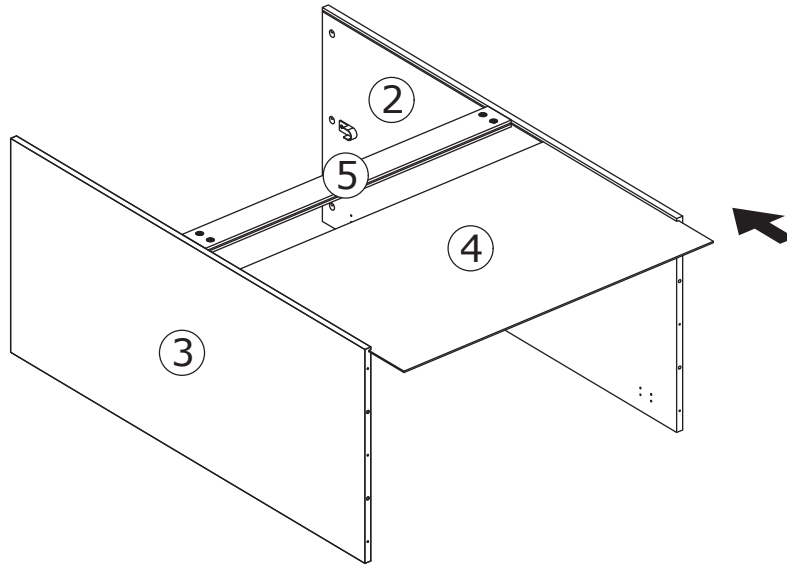

4

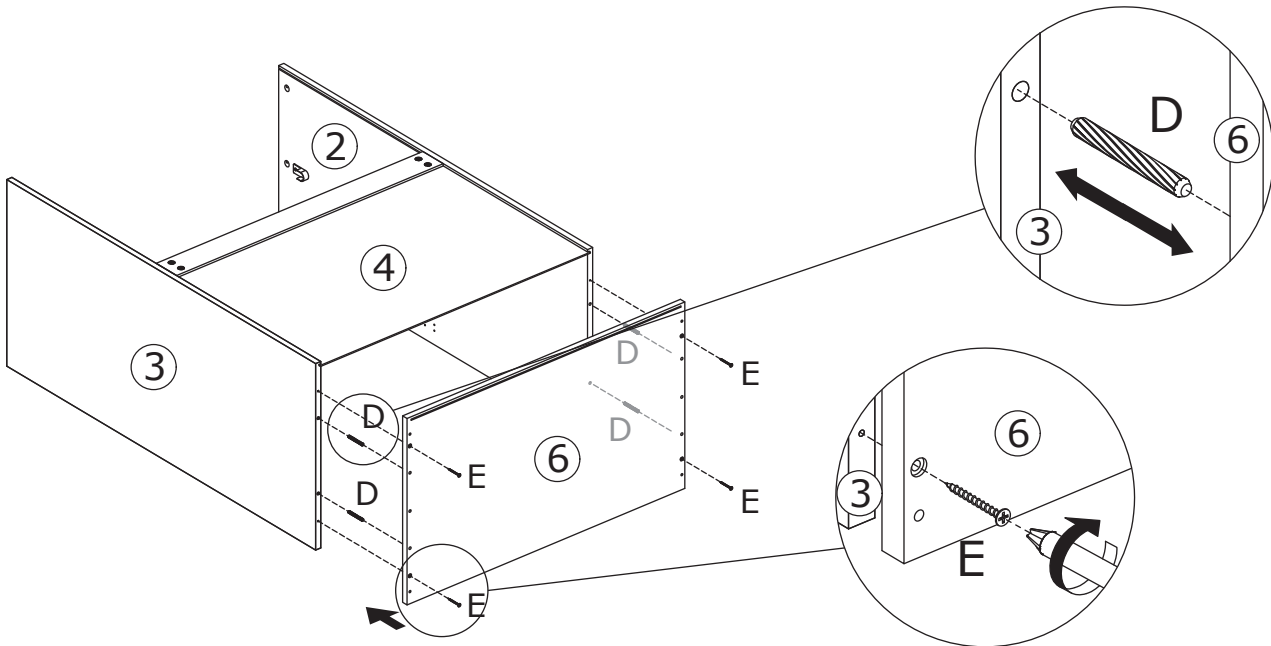
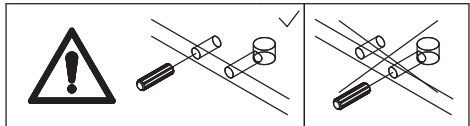

5

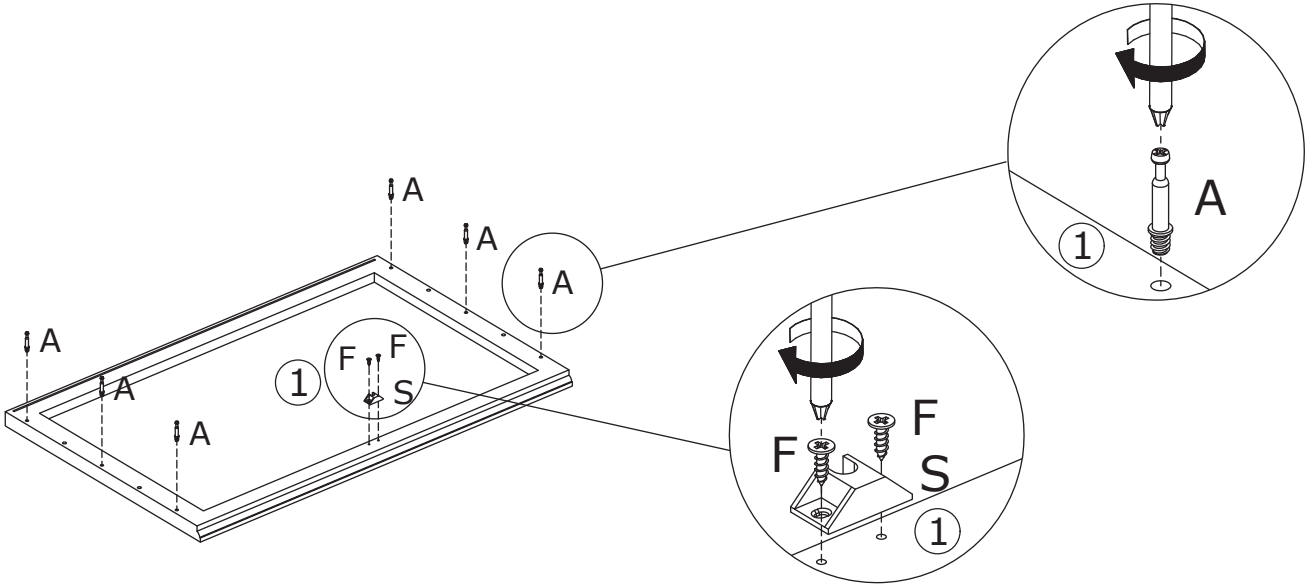
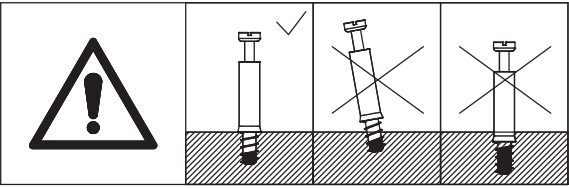
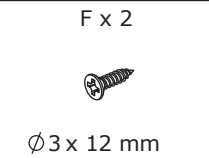
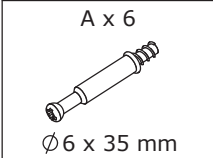

6

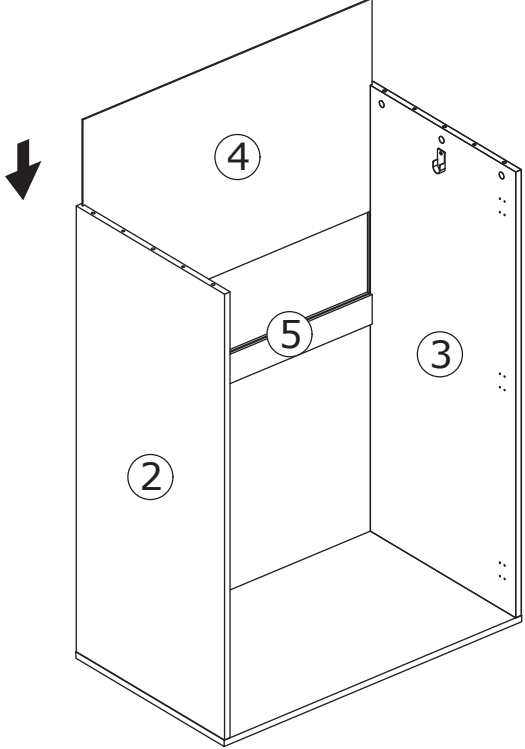

7

B x 6
Ø14 x 9 mm

C x 4
Ø8 x 30 mm

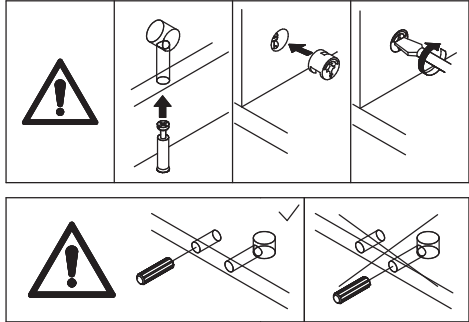
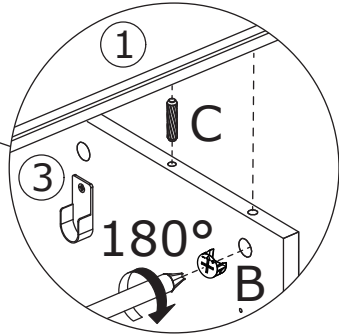
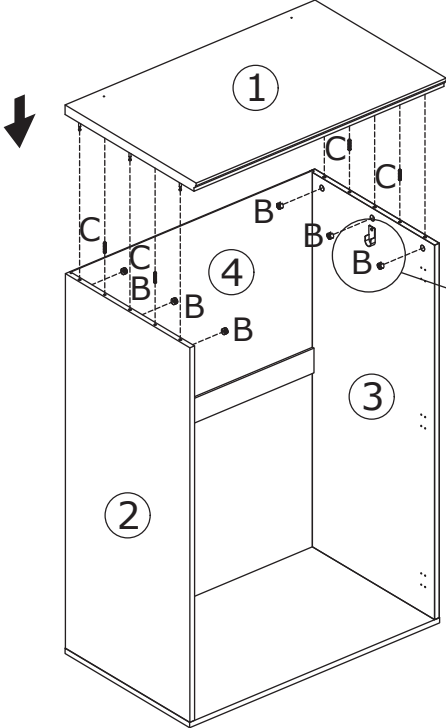

8

M x 2
Ø4 x 14 mm

N x 2

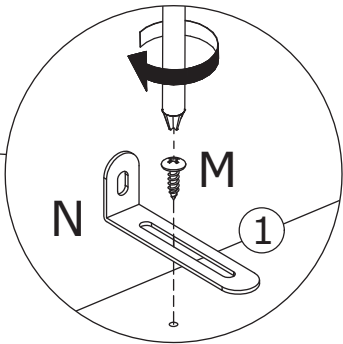
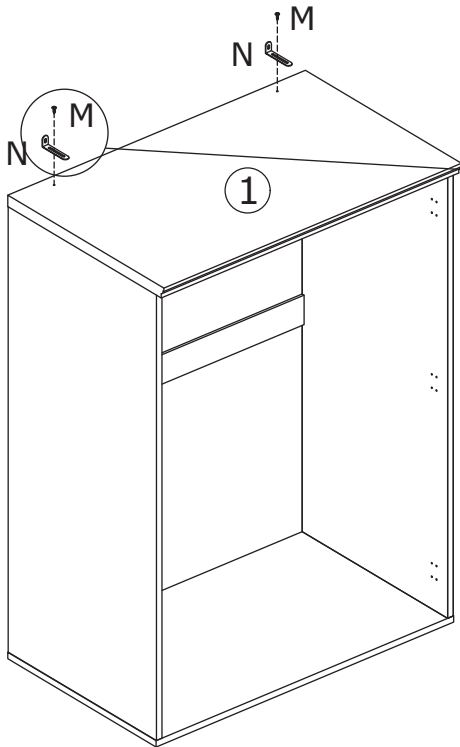

9

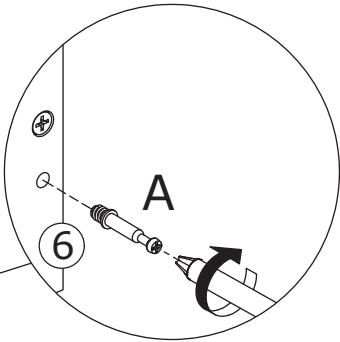
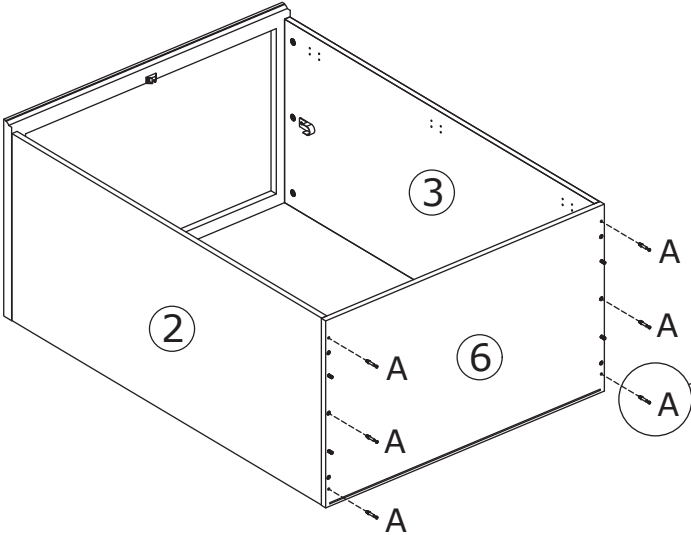
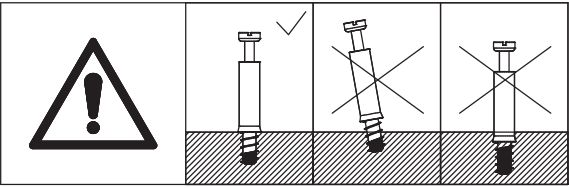
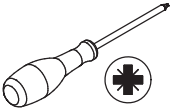
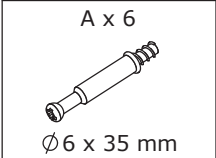

10

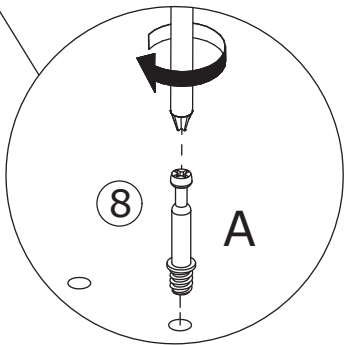
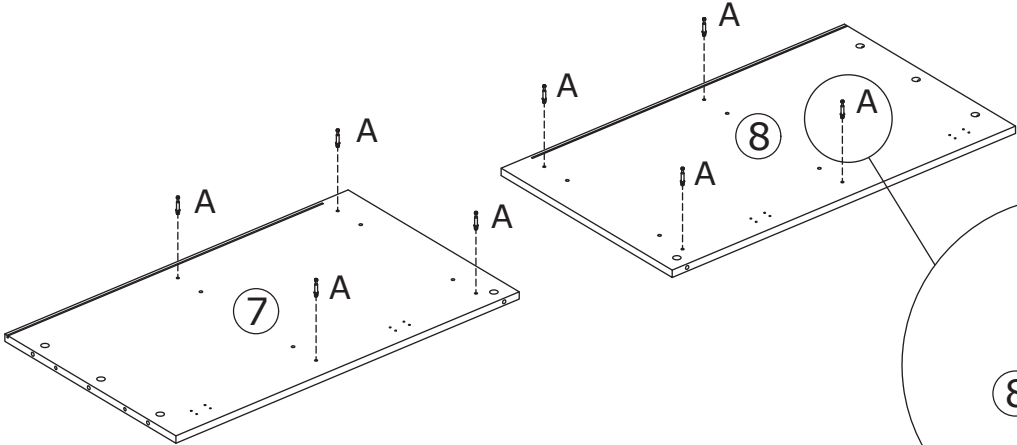
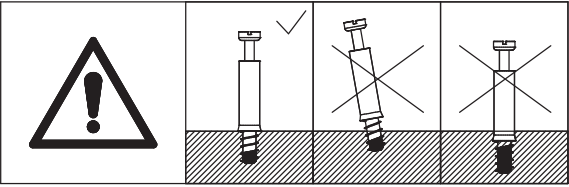
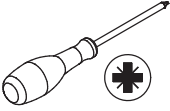
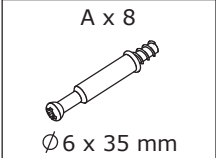

11

B x 4
Ø14 x 9 mm

C x 4
Ø8 x 30 mm

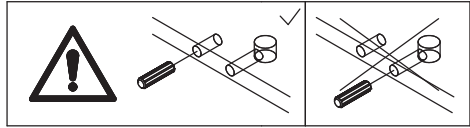
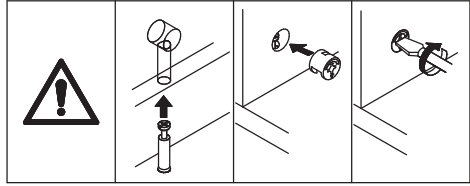
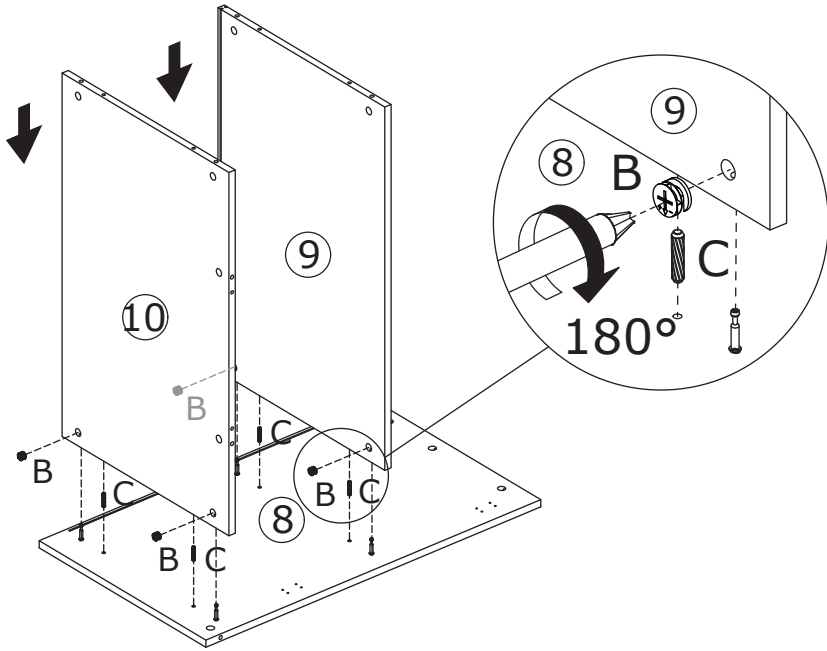

12

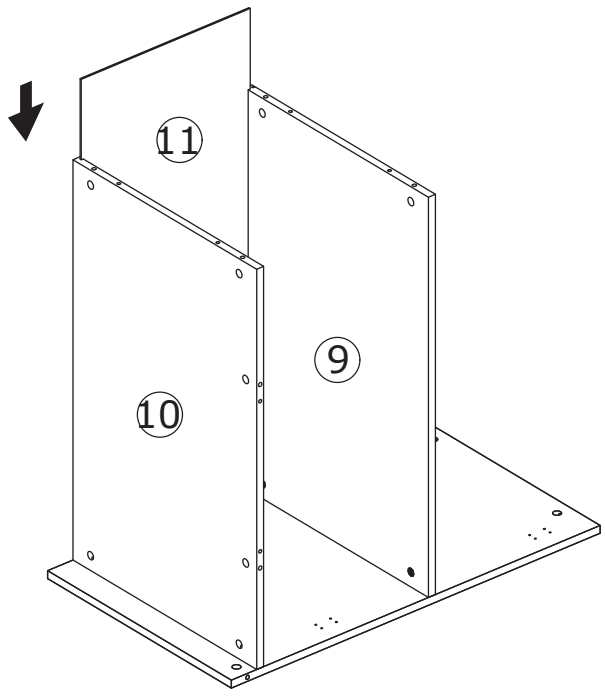

13

B x 4
Ø14 x 9 mm

C x 4
Ø8 x 30 mm

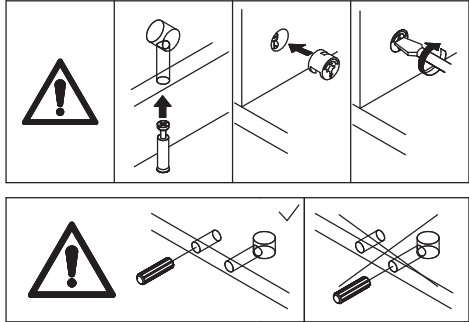
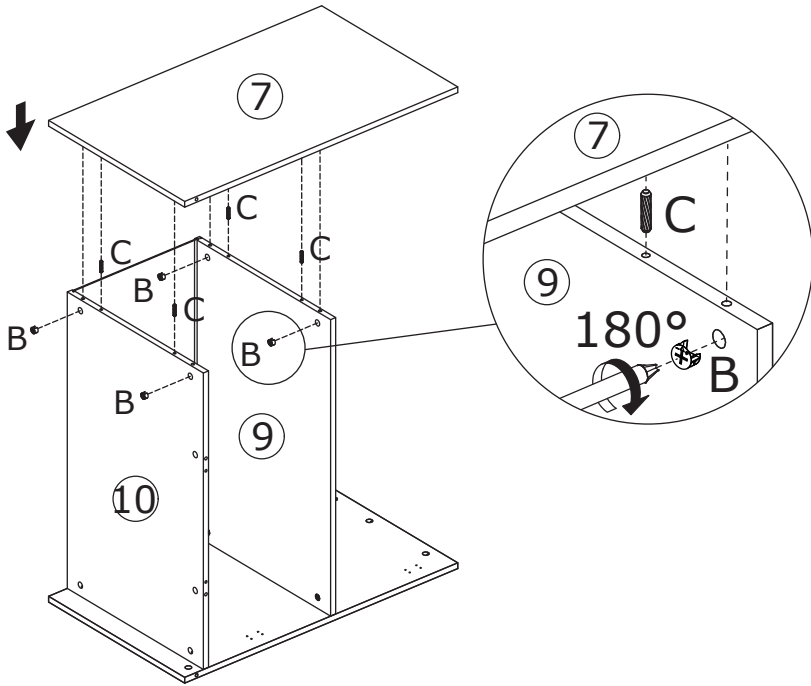

14

A x 4
Ø6 x 35 mm

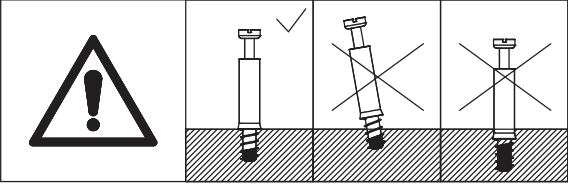
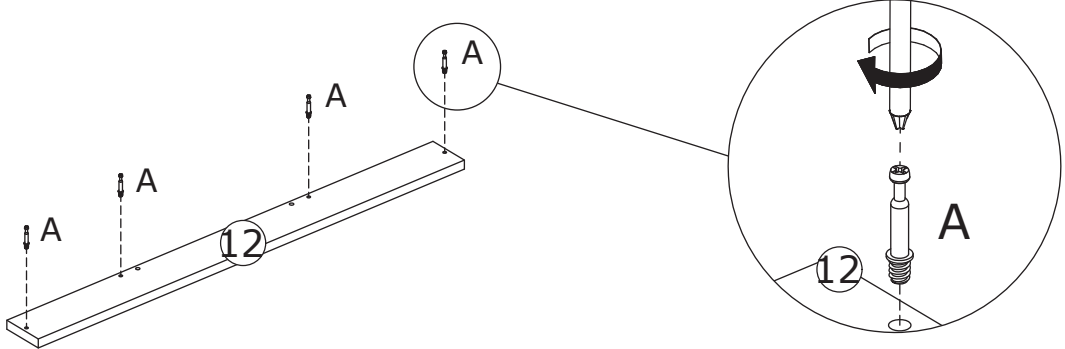

15

B x 4
Ø14 x 9 mm

C x 2
Ø8 x 30 mm

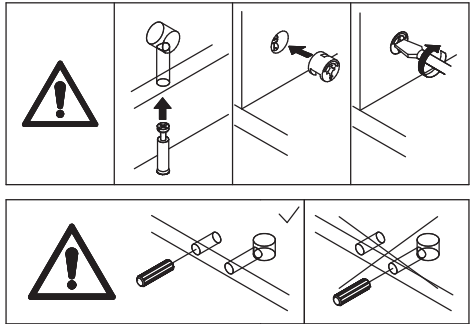
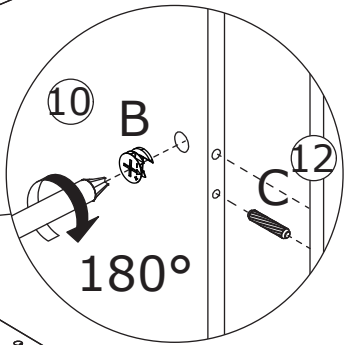
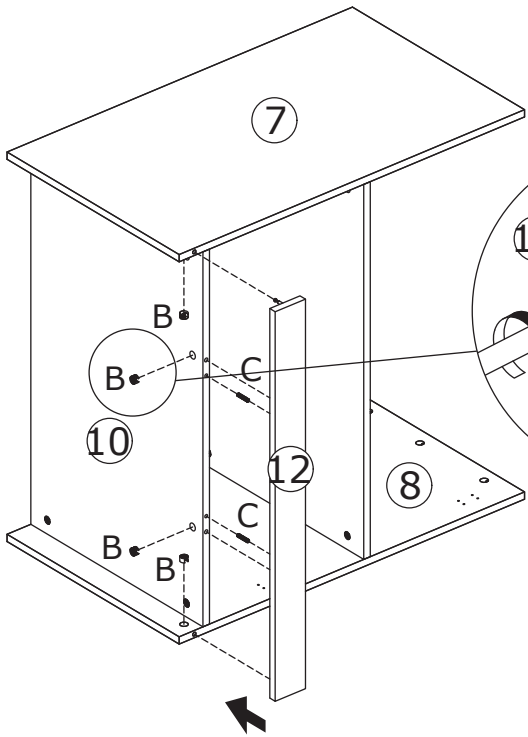
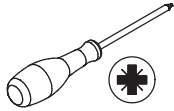

16

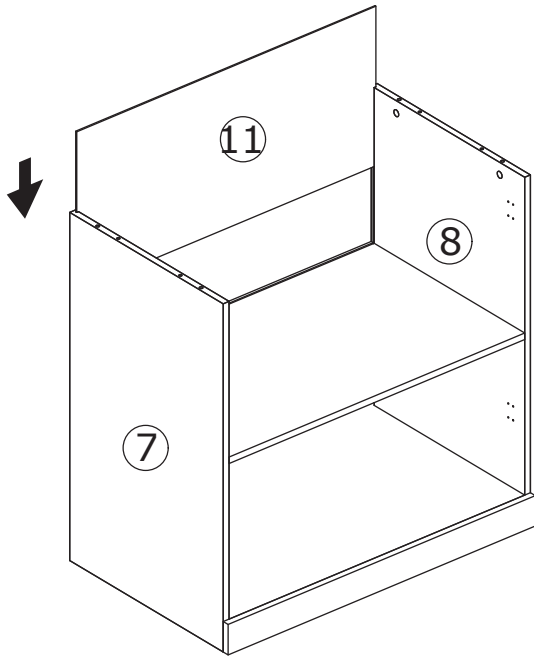

17

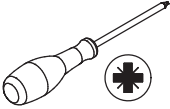
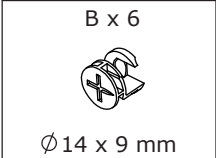

Connect the two component.
Put cam lock(B) into plate 7, 8 and
turn clockwise to tighten as shown.

**We suggest more than two people
to assemble in this step.**

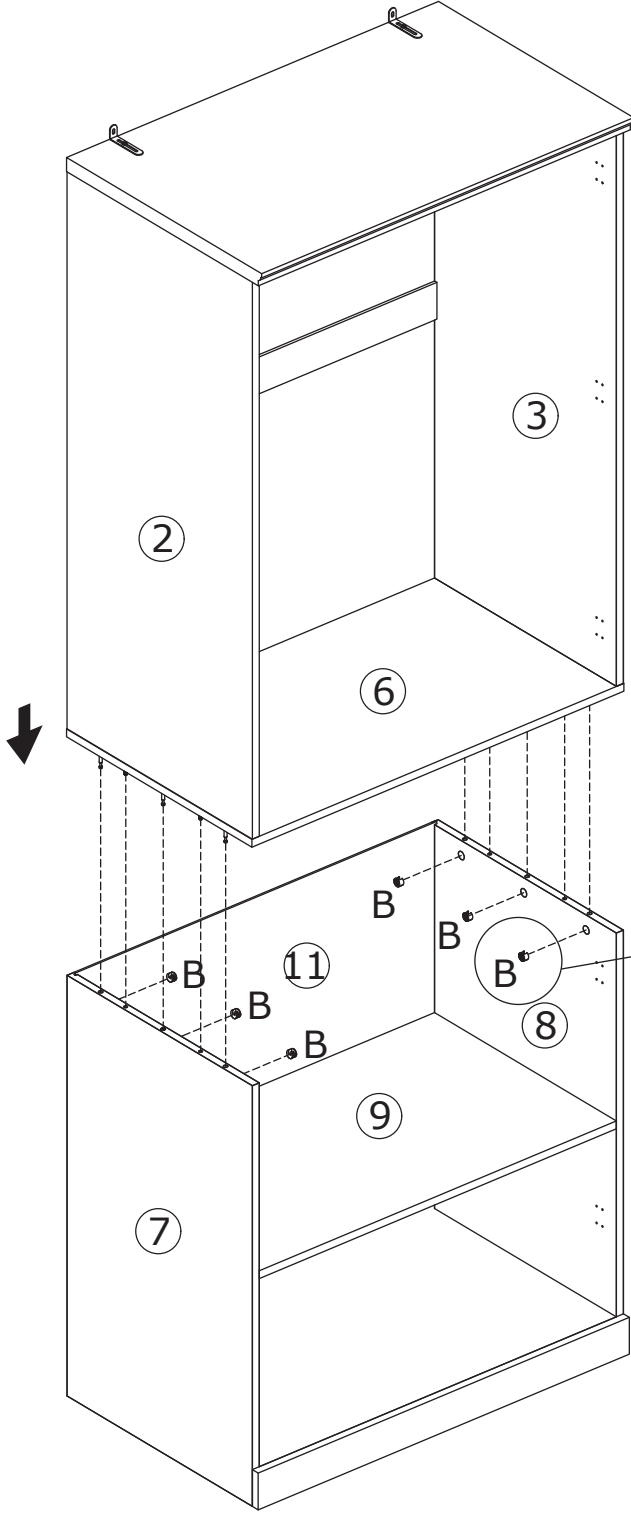
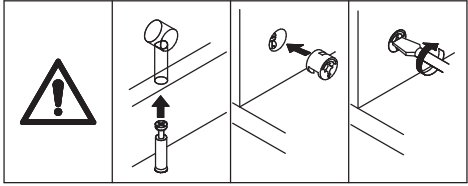

Connectez les deux composants.
Placez le verrou à came (b) dans les
plaques 7, 8, puis tournez dans le
sens horaire pour le serrer, comme
représenté.
**Nous vous recommandons de
réunir plus de deux personnes à
cette étape.**

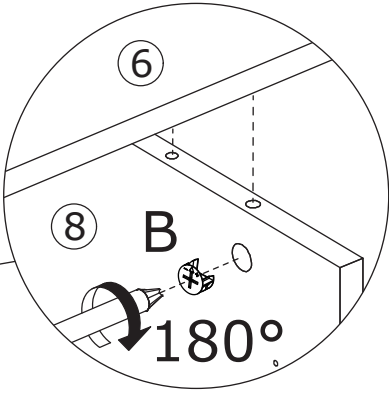

18

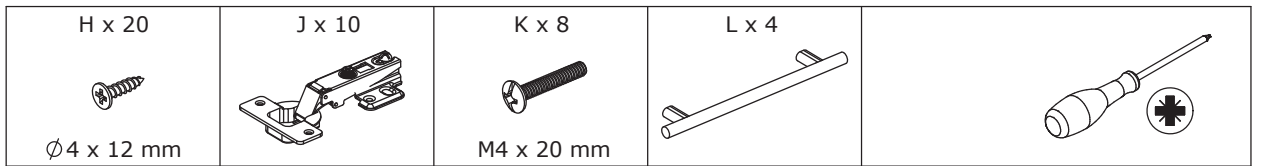

Fix hinge(J) to plate 13, 14, 15 and 16 with screw(H) as shown.
Fix handle(L) with screw(K) as shown.

Fixer la charnière (J) à la plaque 13, 14, 15 et 16 avec vis(H) comme indiqué. Fixez la poignée (L) avec la vis (K) comme indiqué.

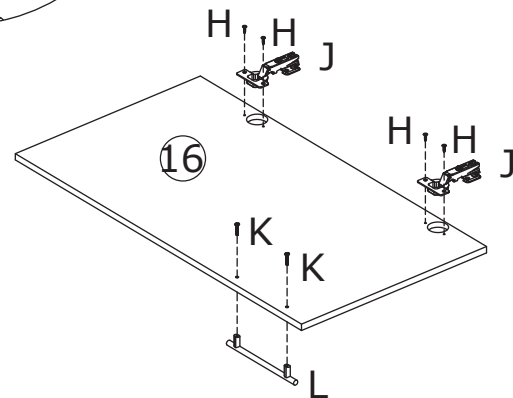
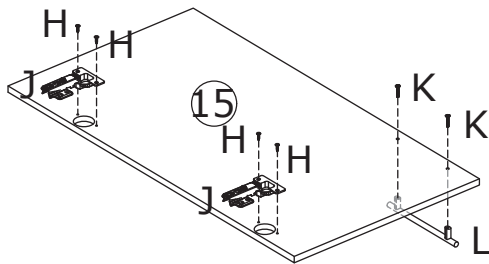
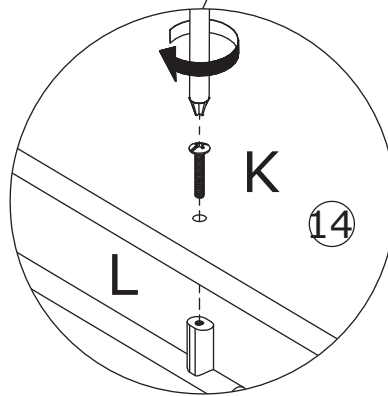
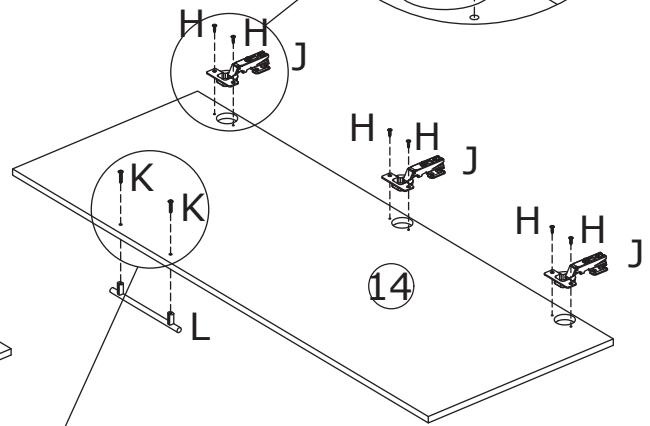
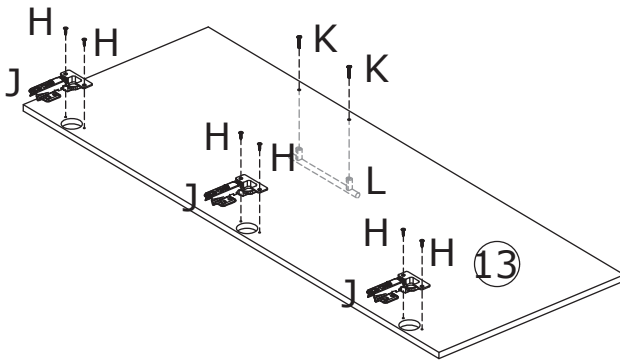
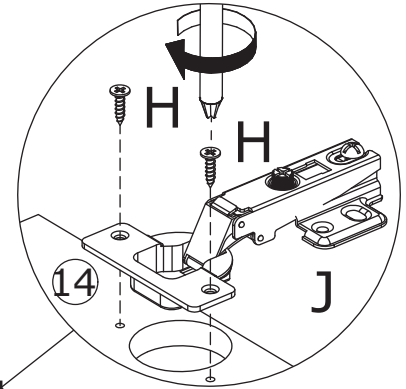

19

H x 40



Ø4 x 12 mm

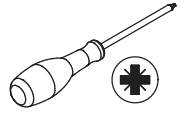

Attach door plate 13 to plate 2; door plate 15 to plate 7; door plate 14 to plate 3; door plate 16 to plate 8 by fixing hinge with screw(H) as shown.

Fixez la plaque de porte 13 à la plaque 2; plaque de porte 15 à plaque 7; plaque de porte 14 à plaque 3; plaque de porte 16 à la plaque 8 en fixant charnière avec vis (H) comme illustré.

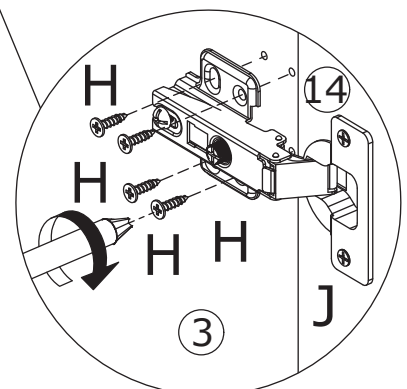
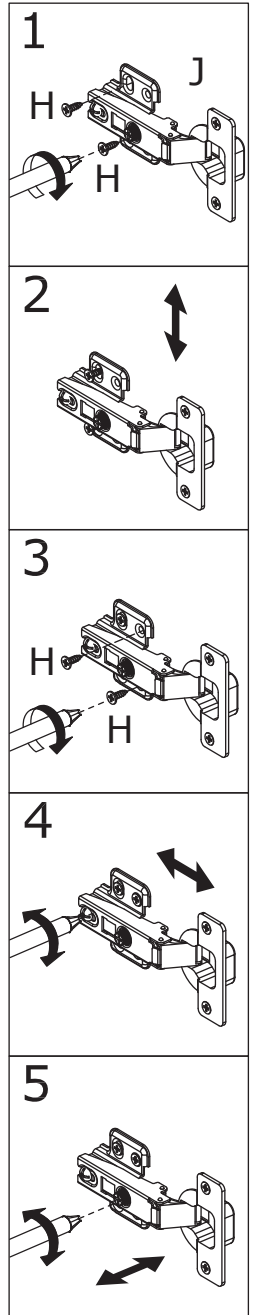
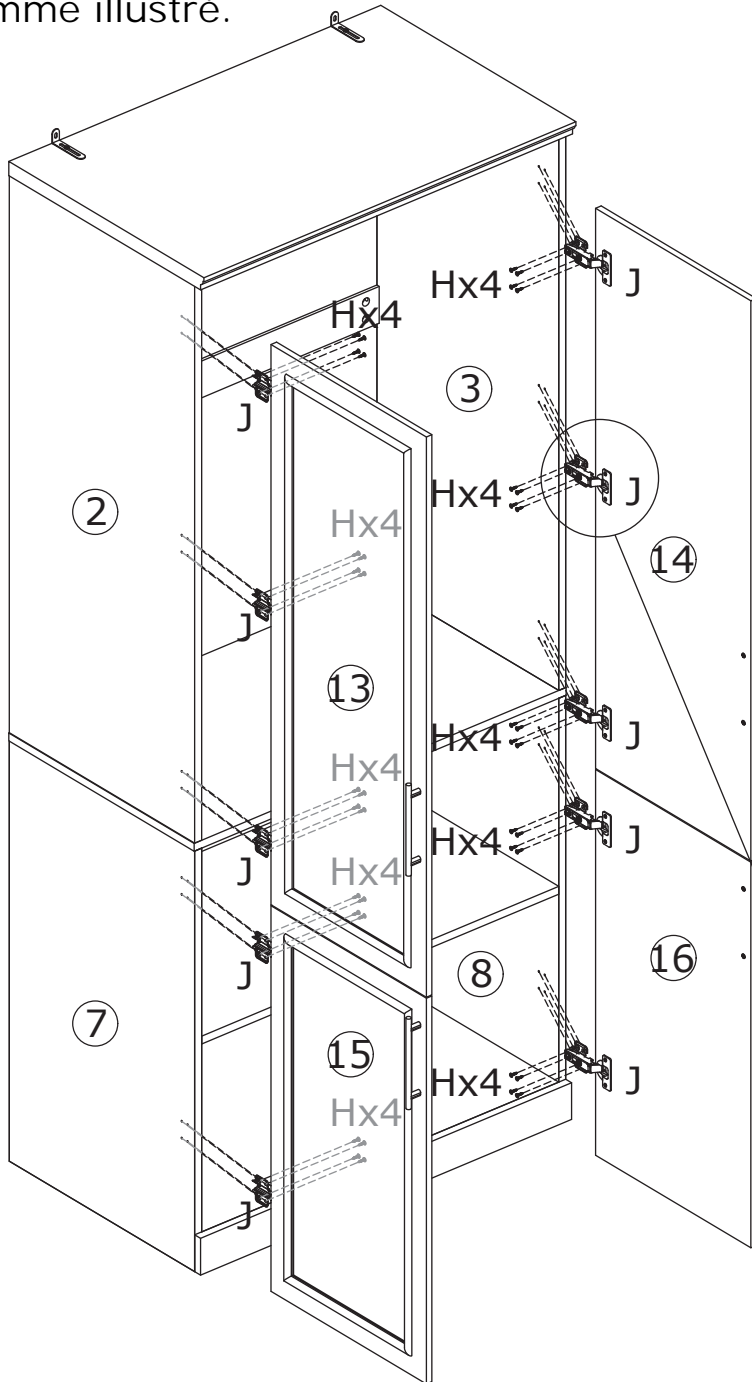

20

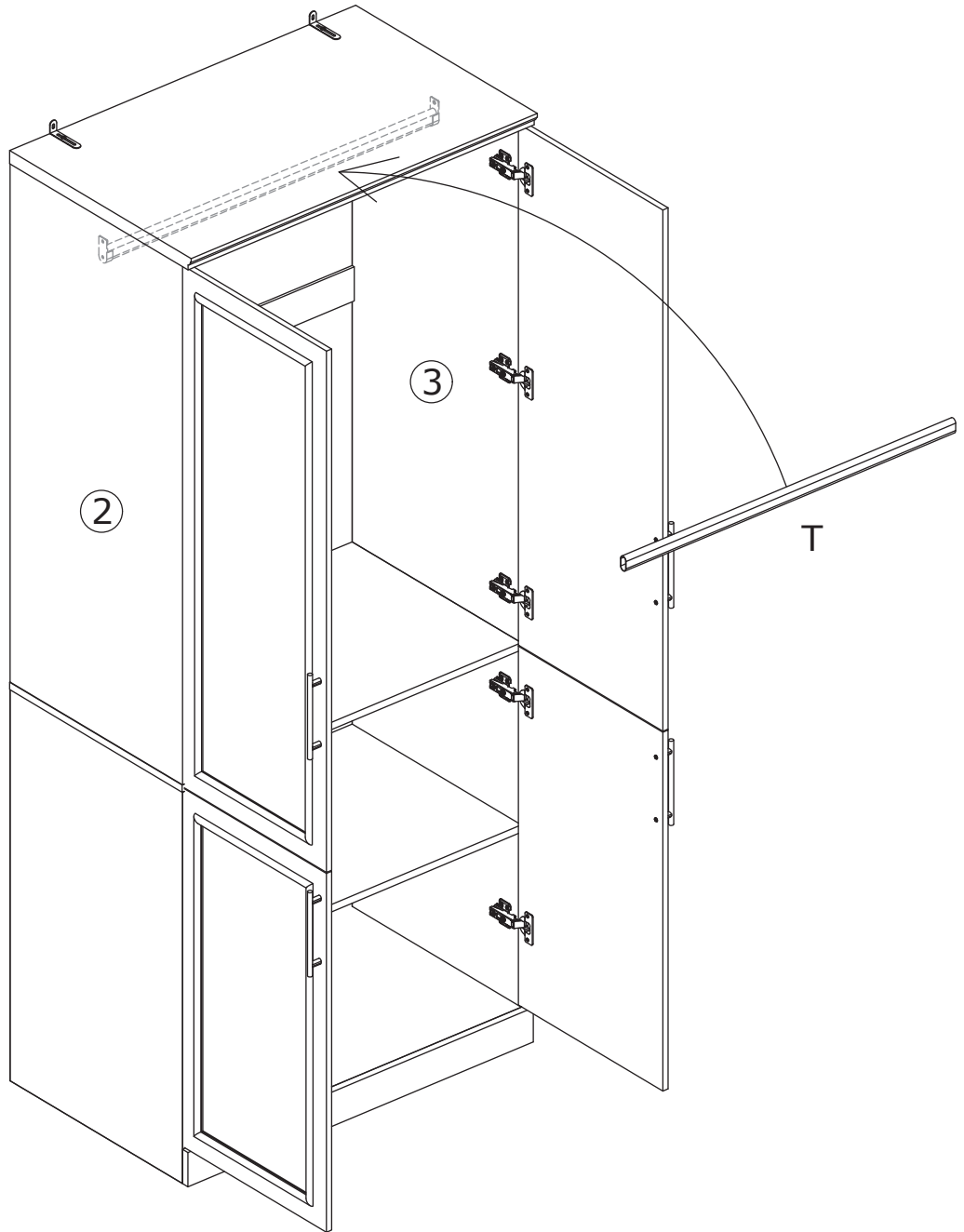
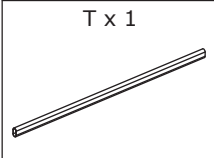

21

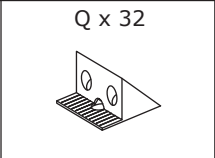
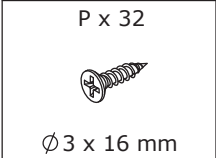

Insert buckle(Q) into back slots,
and fix with screw(P) as shown.

Insérez la boucle (Q) dans les
fentes arrière, et fixez-le avec la
vis (P) comme indiqué.

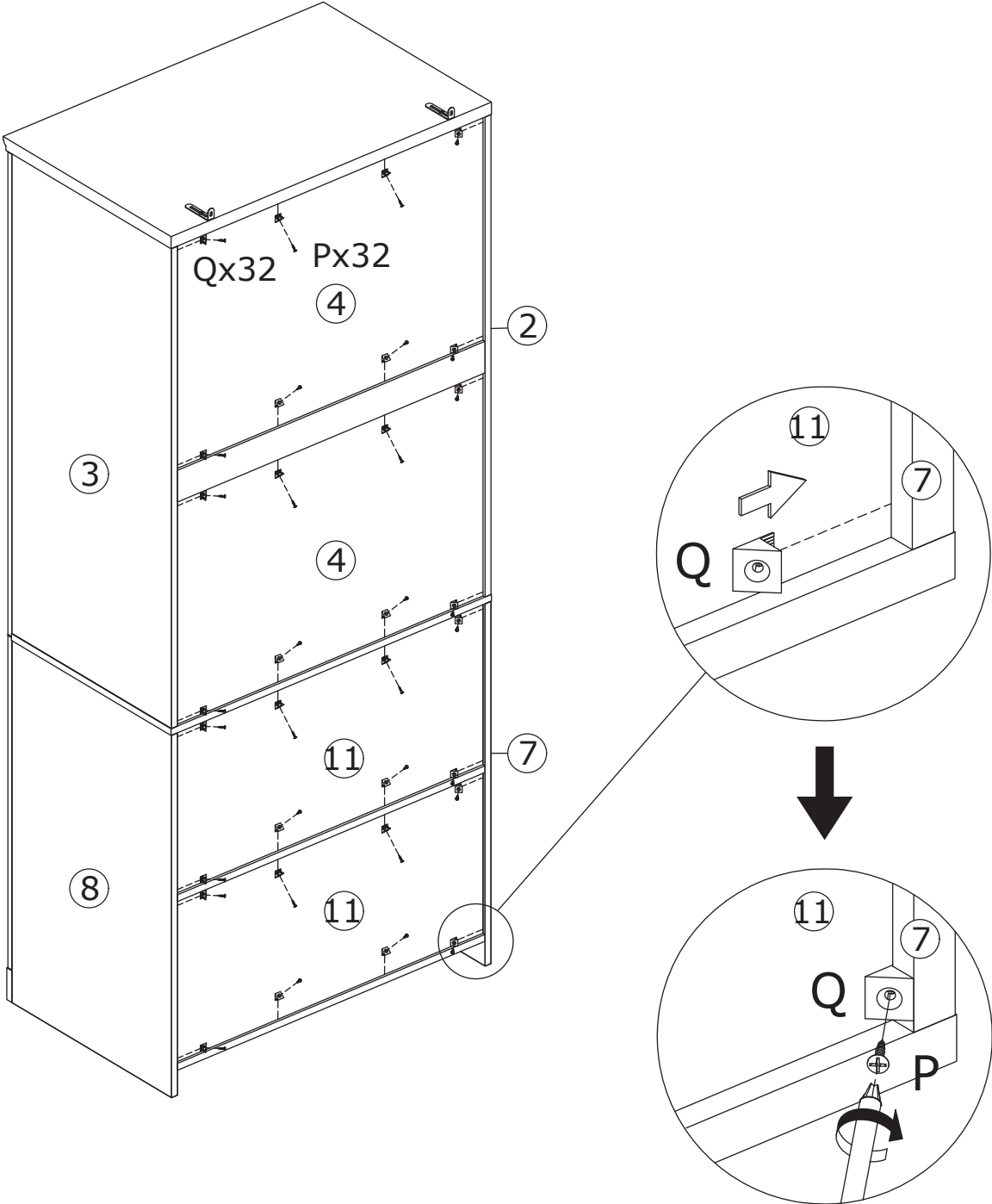

22

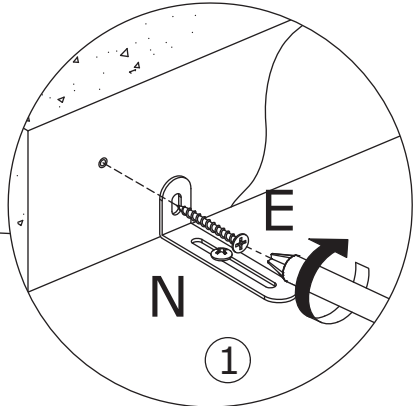
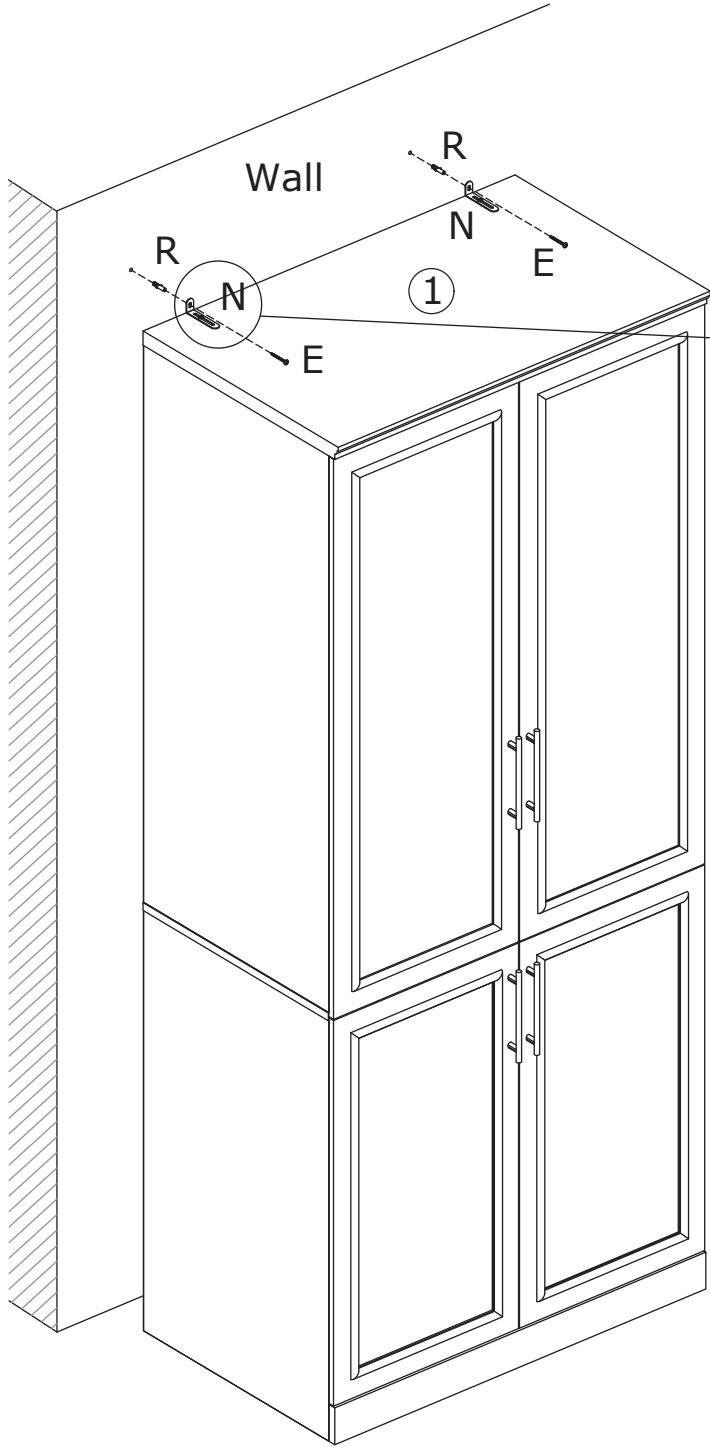
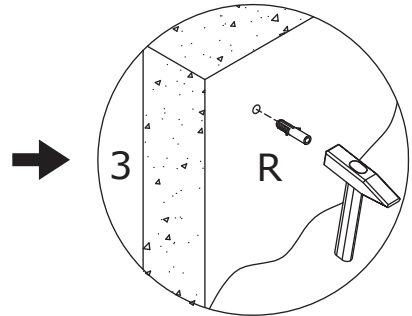
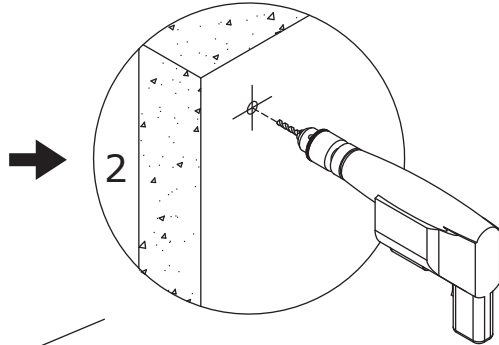
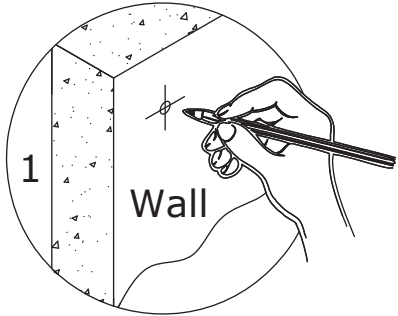
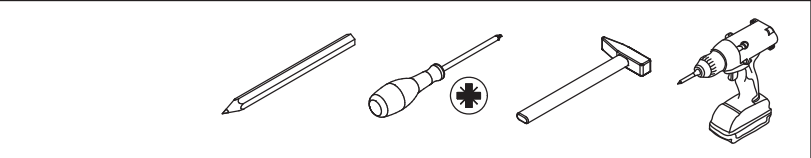
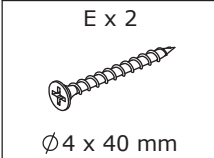

Install anti-tipping device as shown.

Installer un dispositif anti-basculement comme indiqué.

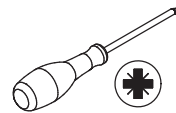

More detailed hinge adjustment mode:

- (1) Rotate out the screws connected with the cabinet counterclockwise, adjust the gap between the overall door frame and the upper and lower, and then rotate the screws clockwise after adjusting;
- (2) Rotate the screws at the end of the hinge counterclockwise to adjust the gap between the whole door frame and the cabinet before and after the adjustment, and then rotate the screws clockwise (rotate out to the movable door frame, do not need to over-rotate out);
- (3) Counterclockwise rotation of the screws in the middle of the hinge will offset the corresponding part of the rear door frame to the left, and clockwise rotation of the screws in the middle of the hinge will offset the corresponding part of the rear door frame to the right.

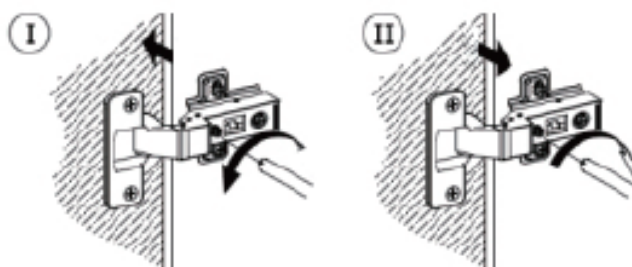
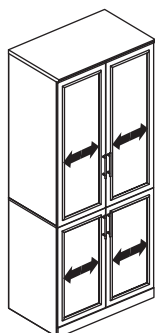
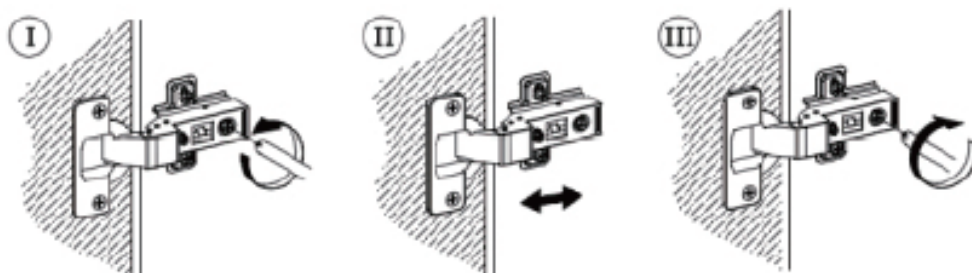
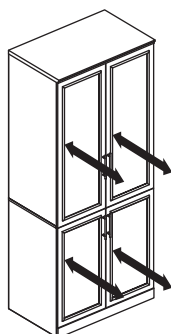
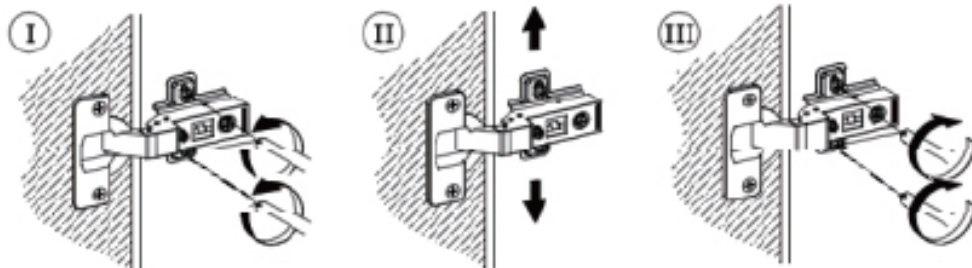
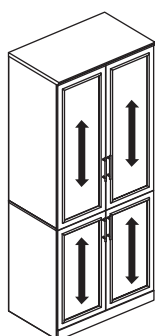

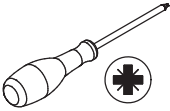

Mode de réglage des charnières plus détaillé:

(1) faites pivoter les vis reliées à l'armoire dans le sens inverse des aiguilles d'une montre,

Ajustez l'écart entre le cadre de porte global et le haut et le bas, et puis tournez les vis dans le sens des aiguilles d'une montre après le réglage;

(2) Tournez les vis à l'extrémité de la charnière dans le sens inverse des aiguilles d'une montre pour régler l'écart entre tout le cadre de la porte et l'armoire avant et après le réglage, puis tournez les vis dans le sens des aiguilles d'une montre (tournez vers la position mobile). cadre de porte, il n'est pas nécessaire de le faire pivoter excessivement) ;

(3) Rotation dans le sens antihoraire des vis au milieu de la charnière décalera la partie correspondante du cadre de porte arrière vers la gauche, et

la rotation dans le sens des aiguilles d'une montre des vis au milieu de la charnière compensera le partie correspondante du cadre de porte arrière vers la droite.

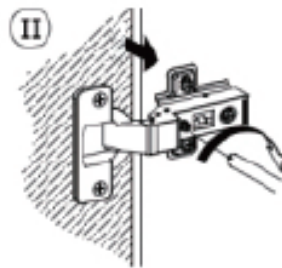
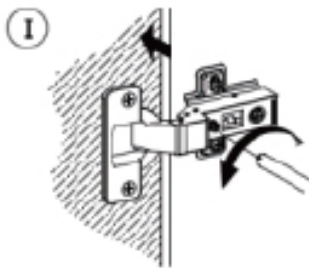
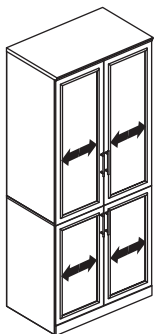
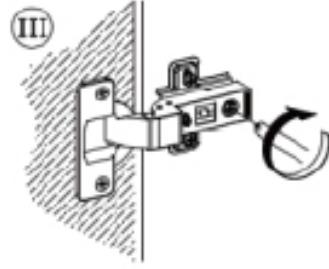
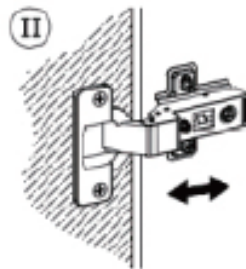
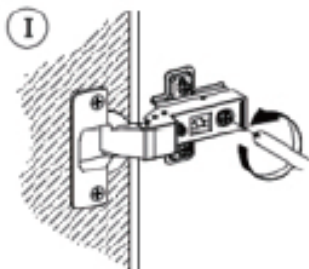
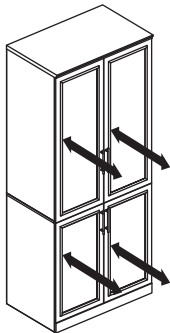
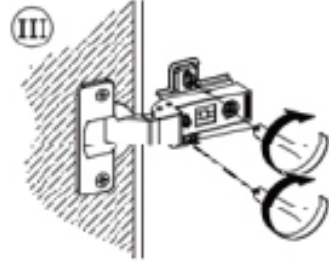
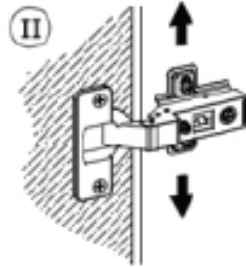
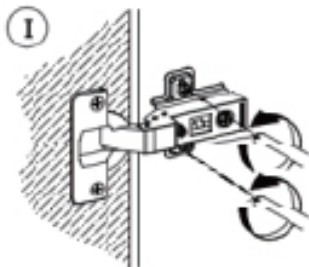
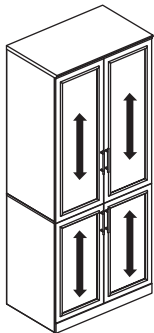

WARRANTY

WARRANTY CLAIMS

- There is a 30-day warranty for broken furniture or any other problems that do not work properly. The warranty will start from the date of purchase which must be verified by proof of purchase.
- Before making a claim, we may be able to answer your query, simply call us. Please leave your purchase order number, along with some details of the problem, if you want a replacement part. We will arrange within 48 hours. If there is out of stock, we will reply with a shipping date.
- The product must be used in accordance with the instructions provided. For health reasons.
- For other reasons, if the furniture needs to be returned, it must be cleaned and dried and operated within 30 days of receipt.

Type of Warranty Claim

- Failure to follow the furniture instructions will invalidate the warranty. Attention please.
- Does not include damage during installation, but includes damage during transportation.

Scope of responsibility

- Shall not bear any responsibility for misuse or user damage and / or loss of parts during the installation of furniture.
- After using, the damage and scratches of the furniture are not covered by the warranty.

The Warranty Relates to All Bought in The Us and Covers The Following Areas

- Sheet parts: 1 month from the date of purchase.
- Electrical parts: 1 month from the date of purchase.

GARANTIE

RÉCLAMATIONS DE GARANTIE

Il existe une garantie de 30 jours pour les meubles cassés ou tout autre problème qui ne fonctionne pas correctement. La garantie commencera à partir de la date d'achat qui doit être vérifiée par une preuve d'achat.

Avant de faire une réclamation, nous pourrions peut-être répondre à votre demande, il vous suffit de nous appeler. Veuillez laisser votre numéro de bon de commande, ainsi que quelques détails sur le problème, si vous voulez une pièce de rechange. Nous organiserons dans les 48 heures. En cas de rupture de stock, nous vous répondrons avec une date d'expédition.

Le produit doit être utilisé conformément aux instructions fournies. Pour des raisons de santé.

Pour d'autres raisons, si les meubles doivent être retournés, ils doivent être nettoyés et séchés et utilisés dans les 30 jours suivant leur réception.

Type de demande de garantie

Le non-respect des instructions du meuble annulera la garantie. Attention, s'il vous plaît.

N'inclut pas les dommages pendant l'installation, mais inclut les dommages pendant le transport.

Portée de la responsabilité

N'assume aucune responsabilité en cas de mauvaise utilisation ou de dommages causés par l'utilisateur et / ou de perte de pièces lors de l'installation du meuble.

Après utilisation, les dommages et rayures du meuble ne sont pas couverts par la garantie.

La garantie s'applique à tous les produits achetés aux États-Unis, dans tous les pays d'Europe et couvre les domaines suivants:

Pièces en tôle: 1 mois à compter de la date d'achat.

Pièces électriques: 1 mois à compter de la date d'achat..