

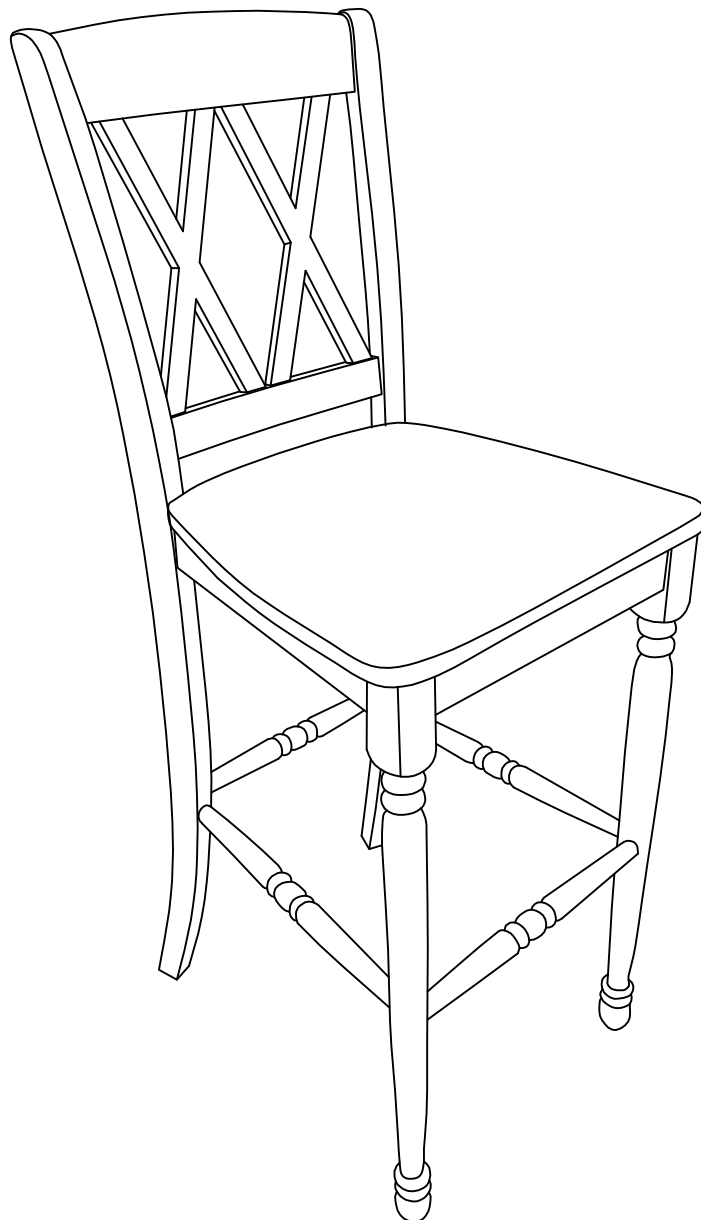

Counter Stool

Bar Stool

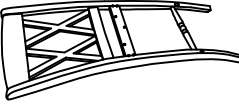

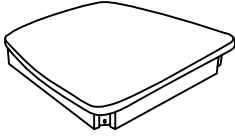
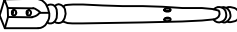
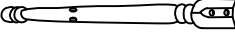
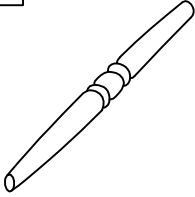

PART LIST

				
<p>Back 2 PCS</p>	<p>Seat Frame 2 PCS</p>	<p>Left Leg 2 PCS</p>	<p>Right Leg 2 PCS</p>	<p>Side Stretcher 4 PCS</p>
				
<p>Front Stretcher 2 PCS</p>				

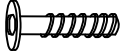
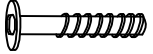
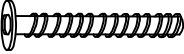
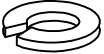
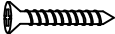
HARDWARE LIST

				
<p>M6 x 40mm Short Bolt 6 PCS (Extra 2)</p>	<p>M6 x 50mm Bolt 8 PCS (Extra 2)</p>	<p>M6 x 80mm Long Bolt 8 PCS (Extra 2)</p>	<p>1/4" Spring Washer 22 PCS (Extra 2)</p>	<p>M4 x 38mm Screw 12 PCS (Extra 2)</p>

	
<p>1/4" Flat Washer 22 PCS (Extra 2)</p>	<p>M4 Allen Wrench 1 PC</p>

ADDITIONAL TOOLS (Not Provided)

Note: It is not recommended to use power tools during assembly.

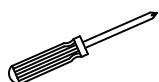

Phillips Head Screwdriver

Step 1. Carefully turn seat frame (part B) upside down on a flat, soft surface, such as carpet. Attach left leg (part C), front stretcher (part F) and right leg (part D) to seat frame (part B) using bolts (part #2), spring washers (part #4), flat washers (part #6) and allen wrench (part #7).

NOTE: Please do not fully tighten bolts until unit is fully assembled.

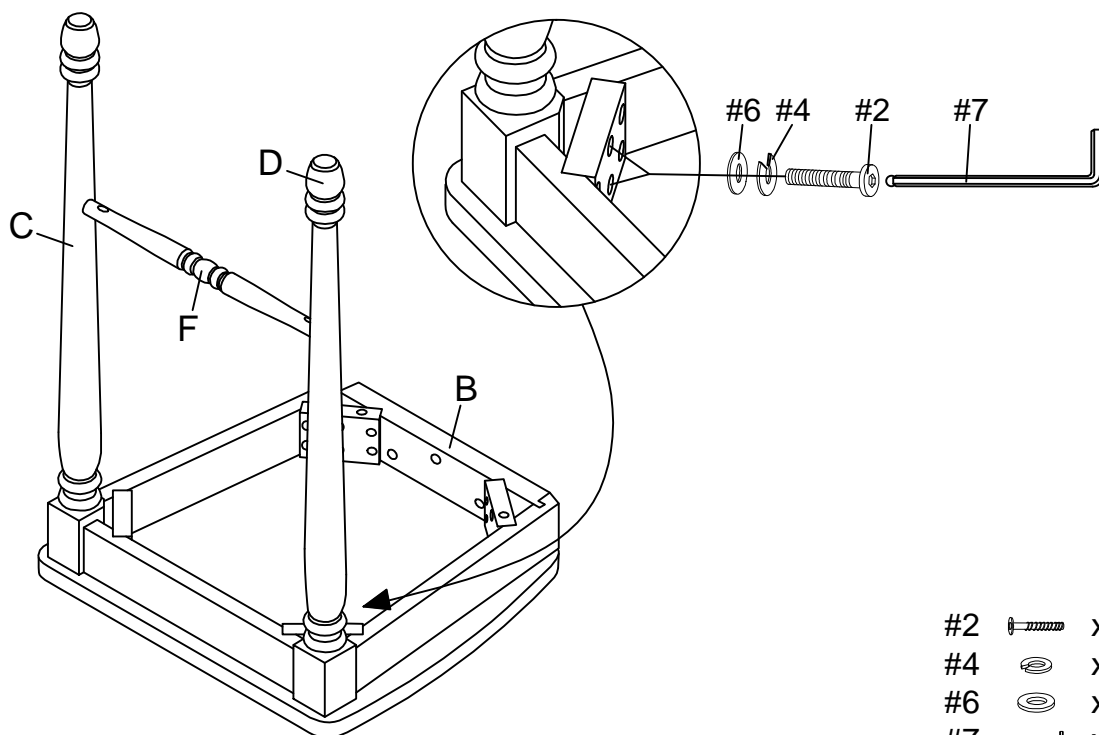



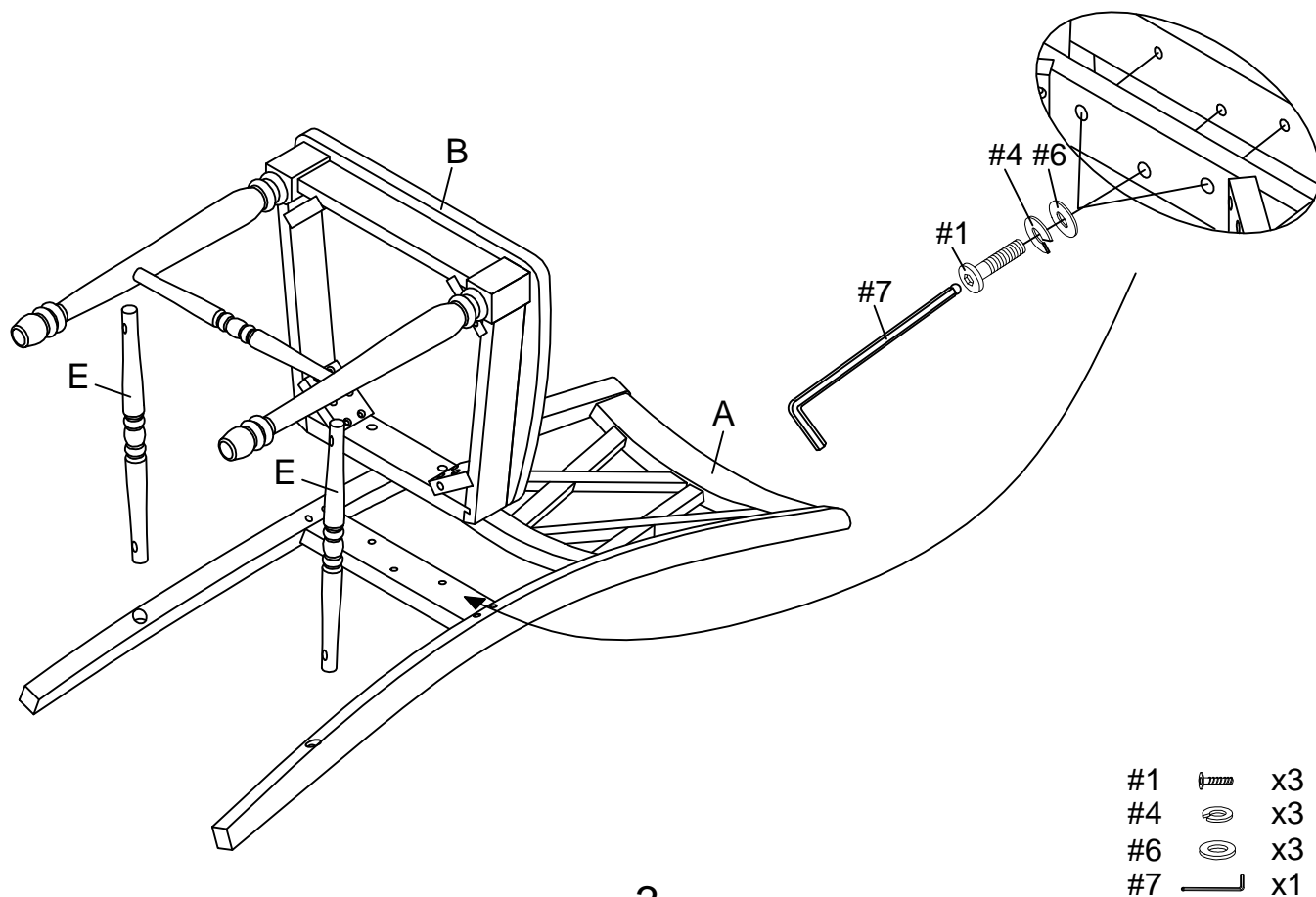

Step 2. Attach seat frame (part B) and side stretchers (part E) to back (part A) using short bolts (part #1), spring washers (part #4), flat washers (part #6) and allen wrench (part #7).

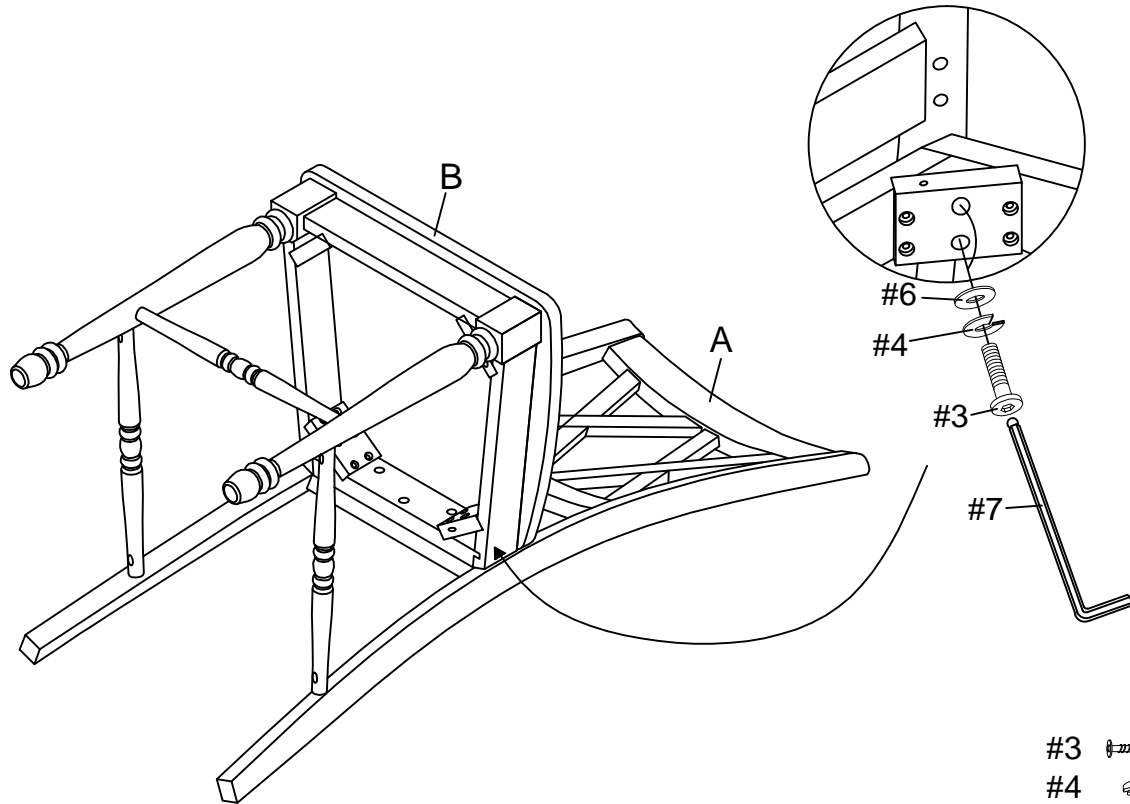

Step 3. Secure corners on seat frame (part B) to back (part A) using long bolts (part #3), spring washers (part #4), flat washers (part #6) and allen wrench (part #7).



- | | | |
|----|---|----|
| #3 |  | x4 |
| #4 |  | x4 |
| #6 |  | x4 |
| #7 |  | x1 |

Step 4. Insert screws (part #5) into the holes of front stretcher (part F) and side stretchers (part E) then tighten using phillips head screwdriver.

NOTE: Please fully tighten all bolts at this time.

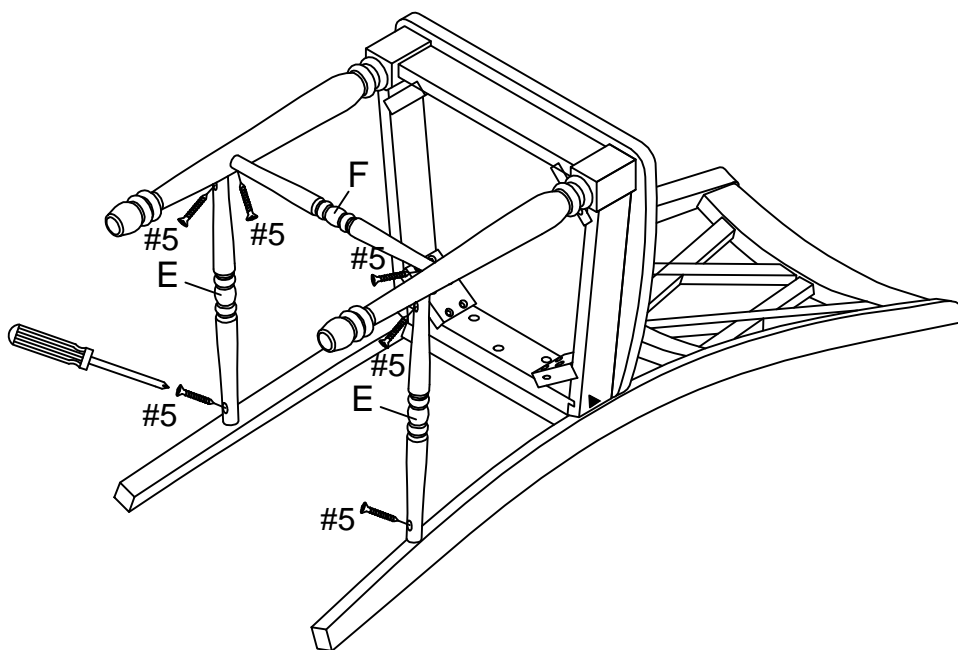

- | | | |
|----|---|----|
| #5 |  | x6 |
|----|---|----|

Step 5. Carefully turn unit upright. Repeat steps 1-4 to assemble remaining chair.

