

# Assembly instruction

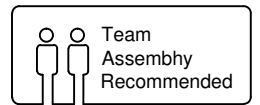

## Tools required

A Phillips head screw driver is required for the assembly of this product. (not included)  
Electric tool should not be used to assemble this product.

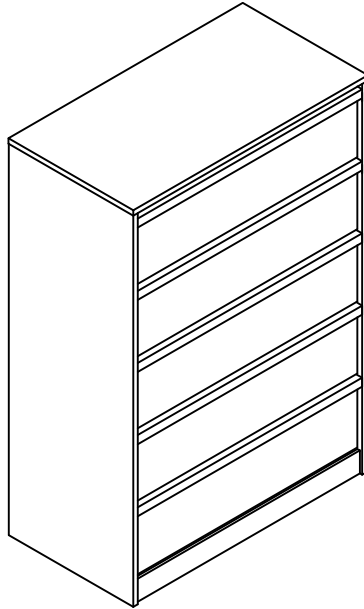
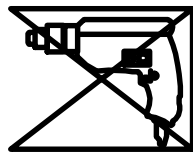
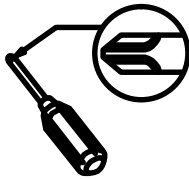

## Two people are needed

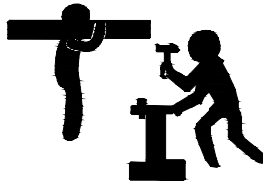

## IMPORTANT SAFETY INFORMATION

- Please carefully read the following instructions and caution warnings before assembling the product.
- Following this guide will ensure that you install, use and maintain the product properly.
- Please keep this installation and user manual/instructions for future reference in case you need to disassemble the product.
- Never allow children to climb onto the product. Ensure that you have special safety measures when children are around on their own.
- Be sure to check that all parts of the product are intact after you open the package.
- Do not assemble if you notice serious damage such as cracks or bends.
- During installation, please use work gloves for hand safety.
- Please assemble the unit on carpeted floor or the flat cardboard box to avoid scratching the surface or your floor while assembling on the floor.
- To assemble, please use the complimentary installation tools (Phillips screwdriver). Pay more attention to the direction of components at each steps.
- It is recommended that two people work together to assemble the product.

## RETURN POLICY

- Please contact us directly within 30 days after receiving.
- Ensure the product is in a good condition with the original box and all original certificates of purchase, manuals, and accessories attached.



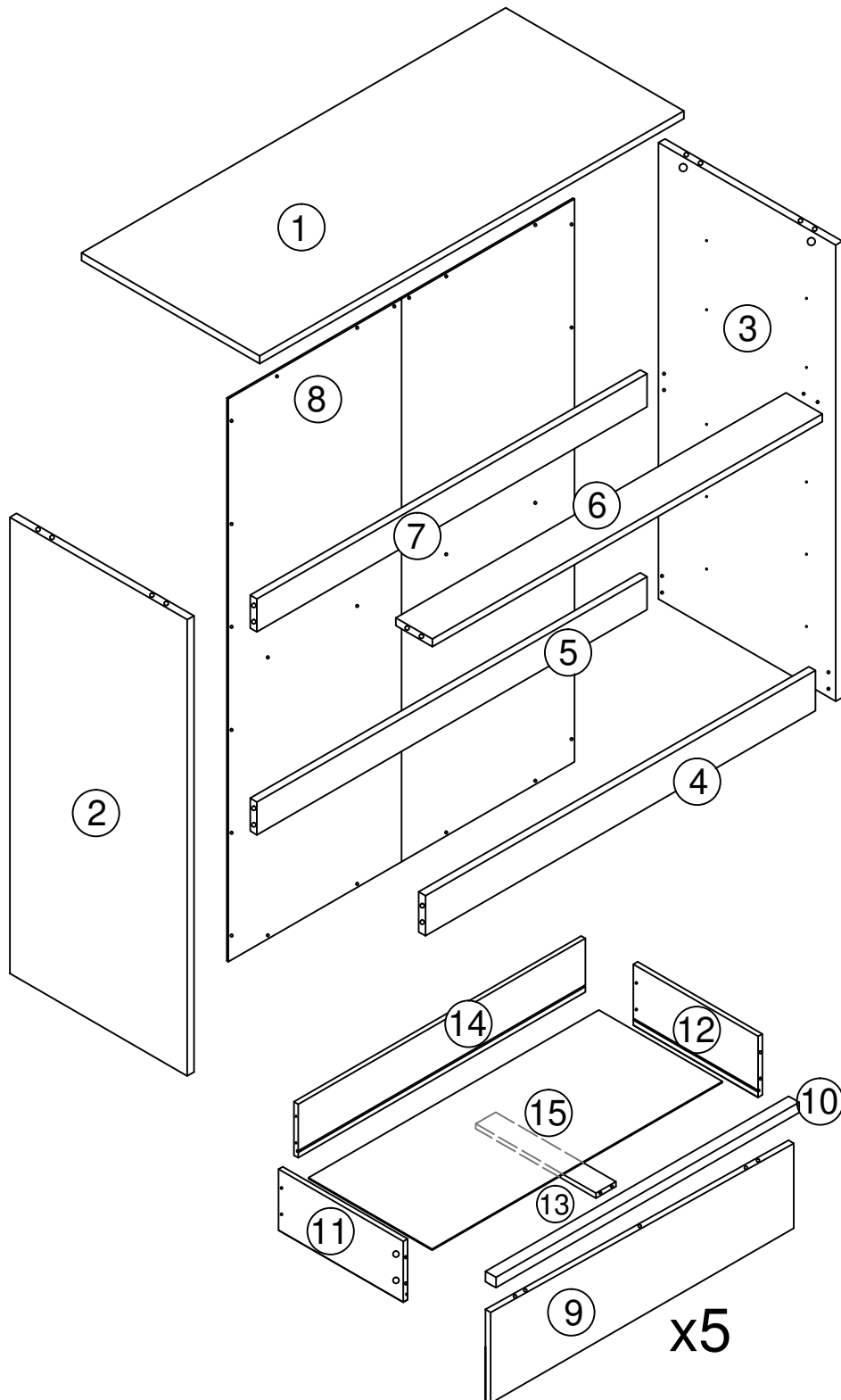





Please check that you have all the parts listed below

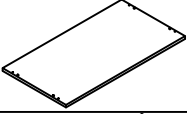

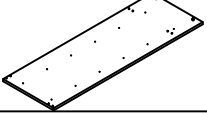
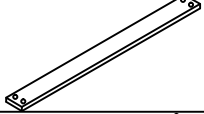
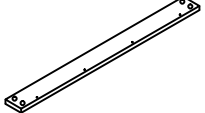
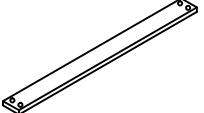
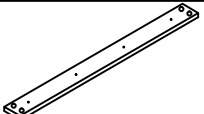
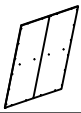
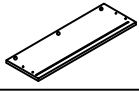







Note: Don't tighten all screws during installation.

# HARDWARE LIST

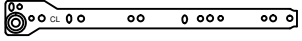
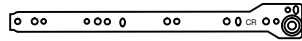
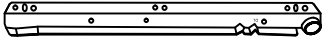
## Components:

	① X1
	② X1
	③ X1
	④ X1
	⑤ X1
	⑥ X1
	⑦ X1
	⑧ X1
	⑨ X5
	⑩ X5
	⑪ X5
	⑫ X5
	⑬ X5
	⑭ X5
	⑮ X5

## Screws & Tools:

Ⓐ		∅8*28mm	65+1pcs
Ⓑ		∅15x9 mm	65+1pcs
Ⓒ-L			5pcs
Ⓒ-R			5pcs
Ⓓ-L			5pcs
Ⓓ-R			5pcs
Ⓔ		∅3.5x14 mm	40+1pcs
Ⓕ		∅3.5x35 mm	30+1pcs
Ⓜ		∅8x30 mm	14+1pcs
Ⓛ		∅4x14 mm	24+1pcs
Ⓢ			1pcs

Check all the components & screws before assembly.  
Do not install in case part is missing, contact us to get.  
Send email with your question to [support@idealhouse.vip](mailto:support@idealhouse.vip).  
We will resend within 24 hours.

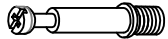
(A) x 16pcs  

# Step 1

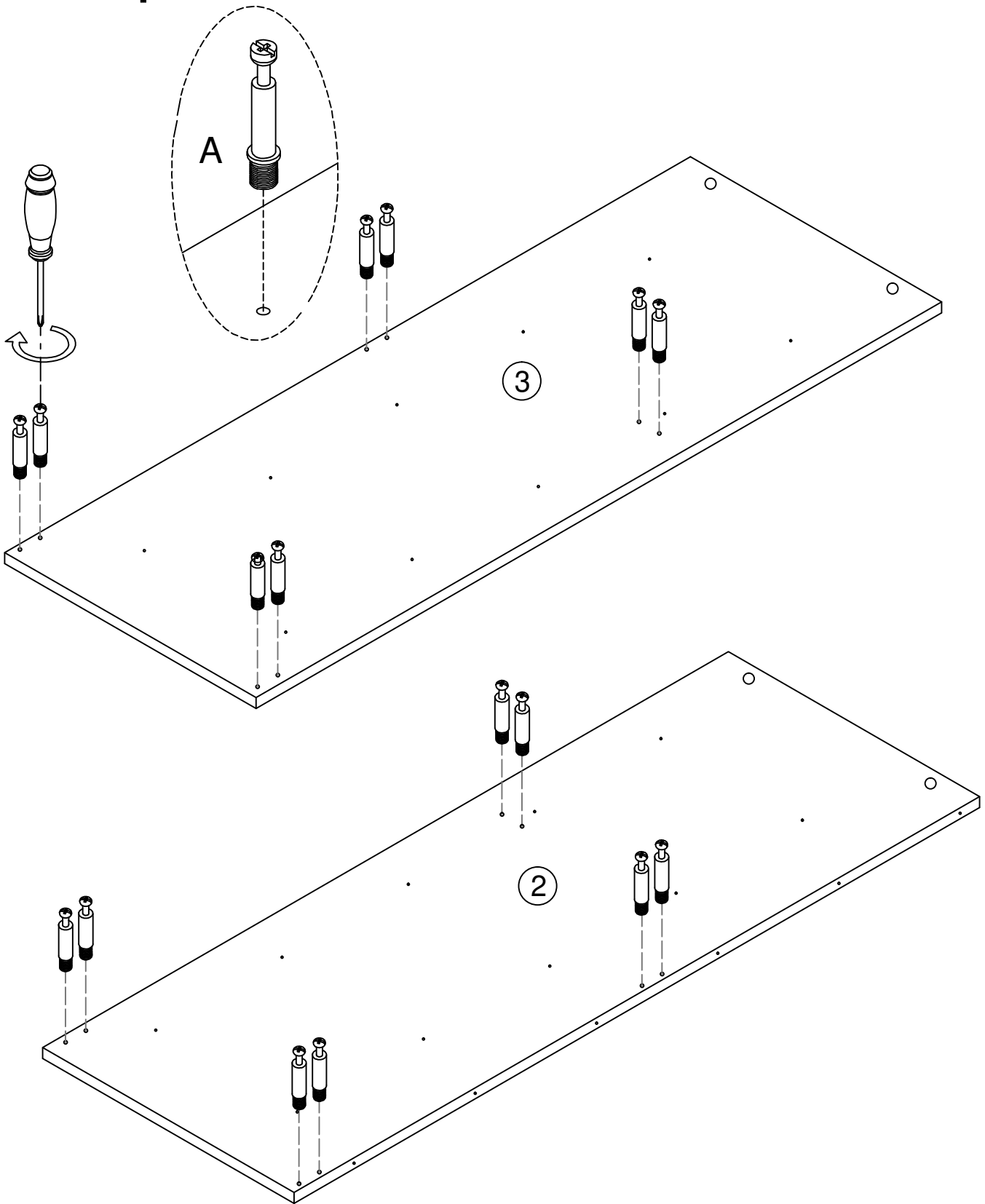

# Step 2

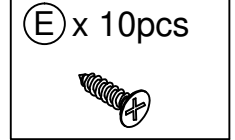
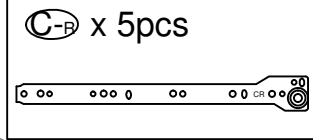

Noted the distance of glide to edge is 32mm

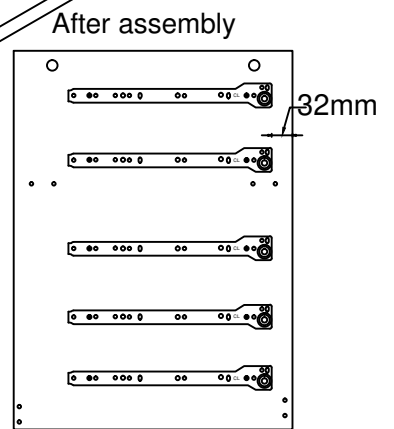
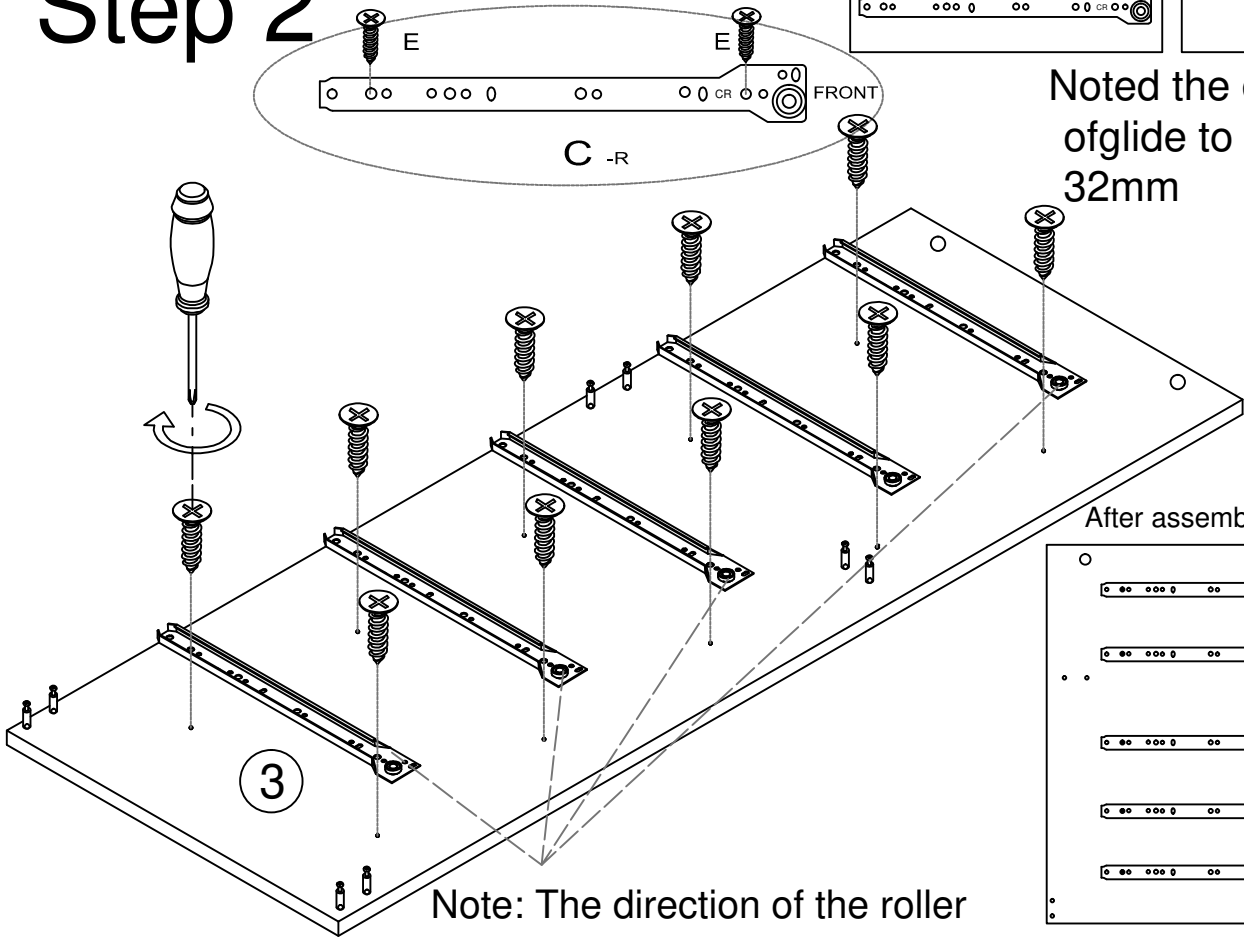

Note: The direction of the roller

# Step 3

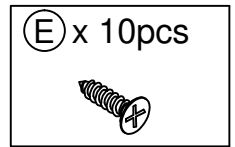
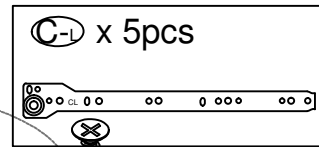

Note: The direction of the roller

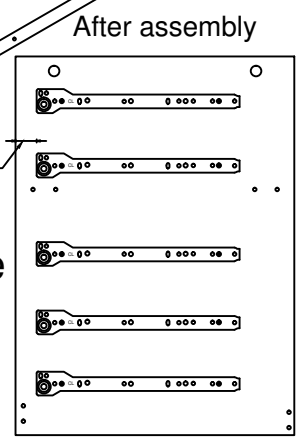
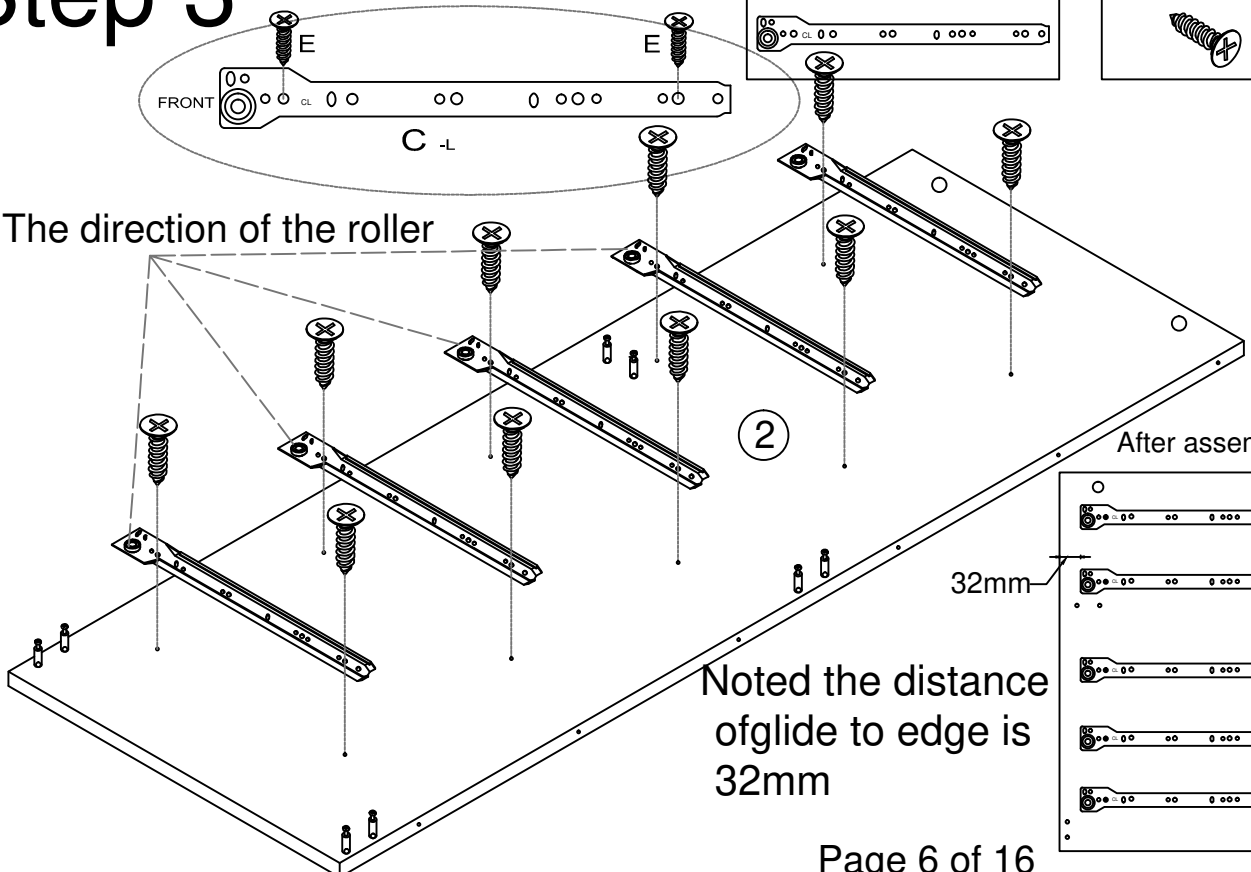

Noted the distance of glide to edge is 32mm

(B) x 8pcs  

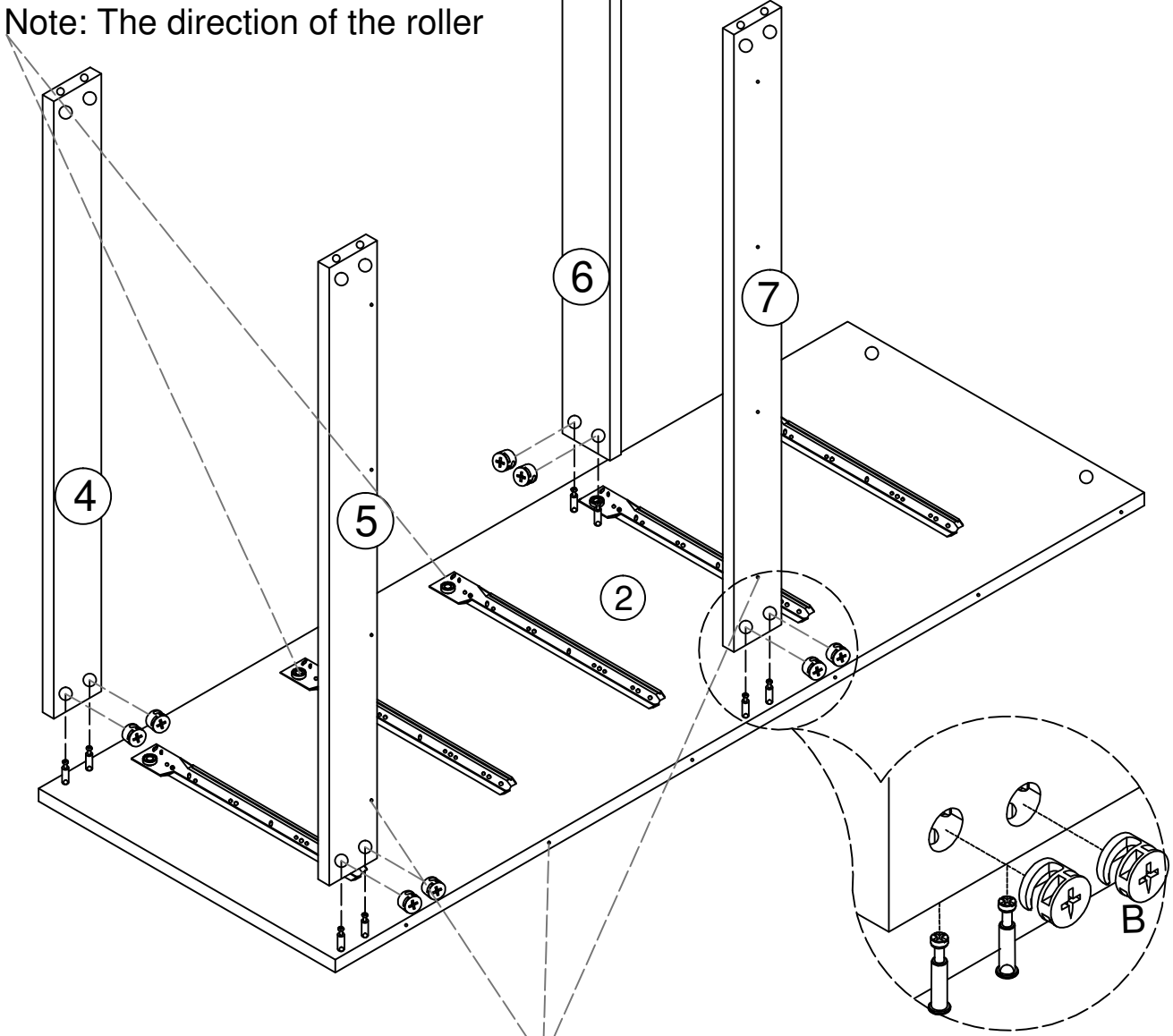

# Step 4

Note: The direction of the roller



Pay attention to hole location

Pay attention to hole location

Ⓑ x 8pcs  

# Step 4

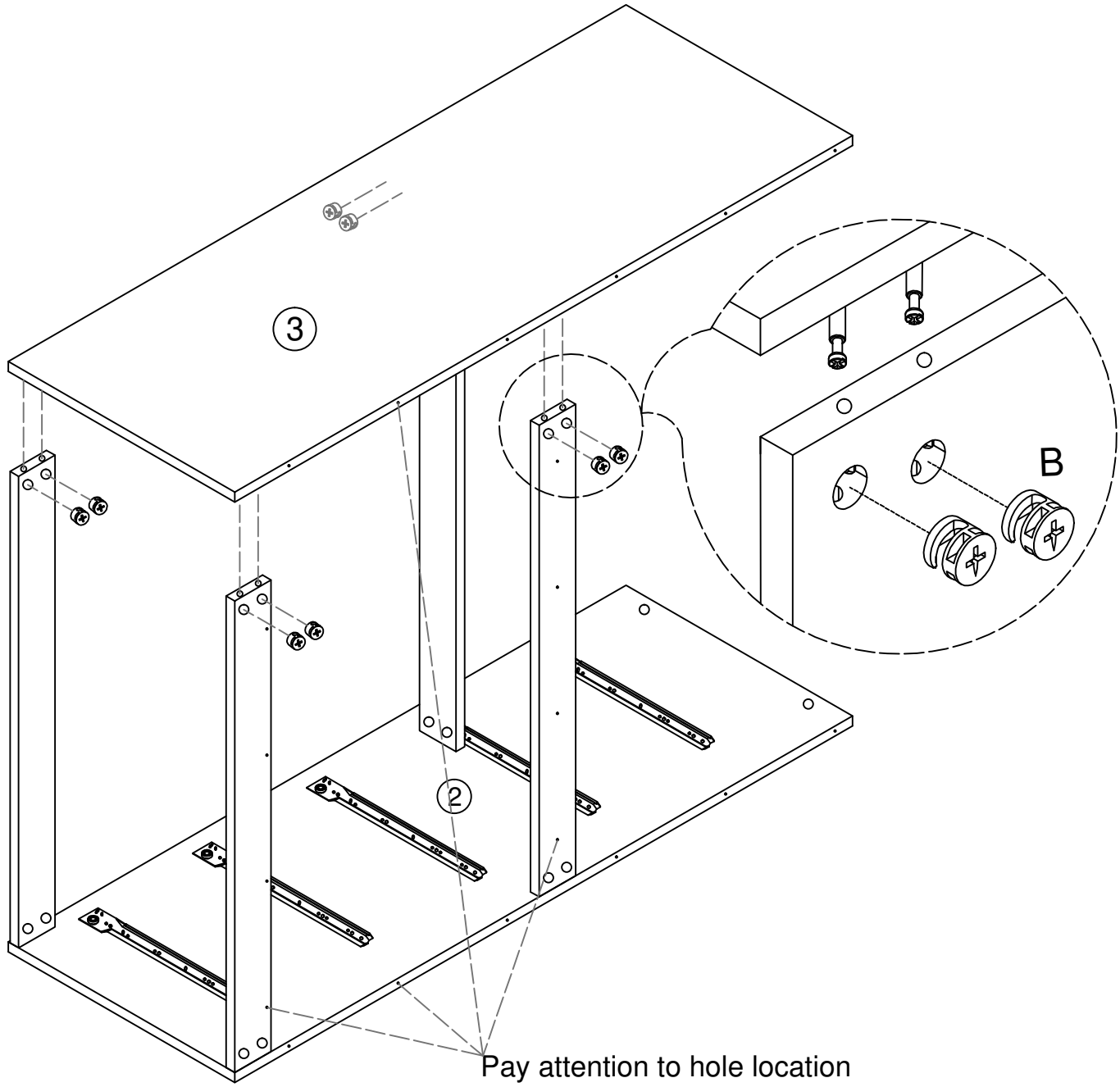

Pay attention to hole location

Pay attention to hole location

# Step 8

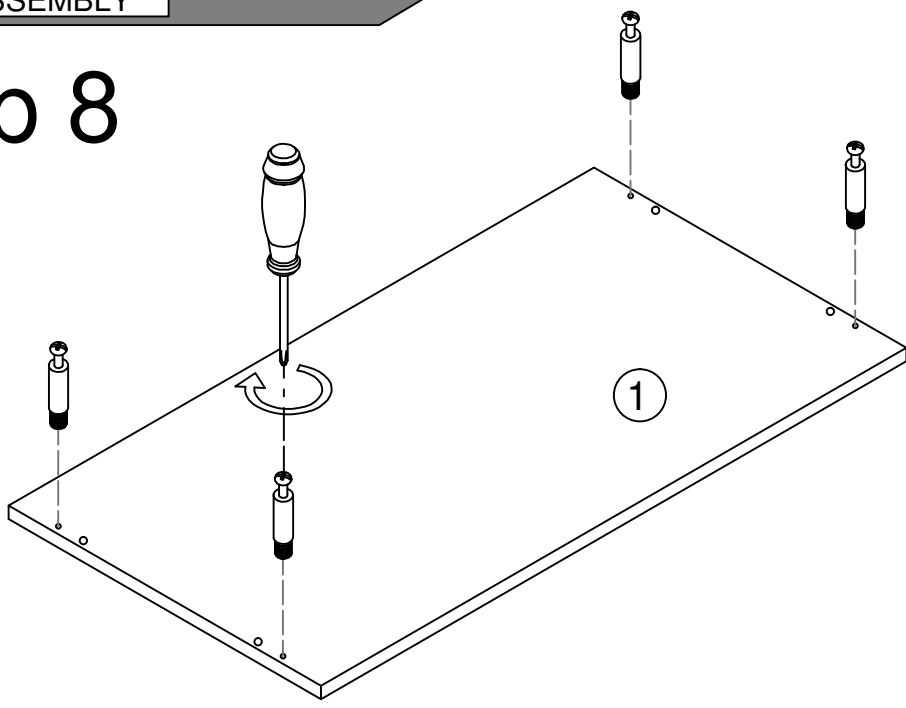

(A) x 4pcs

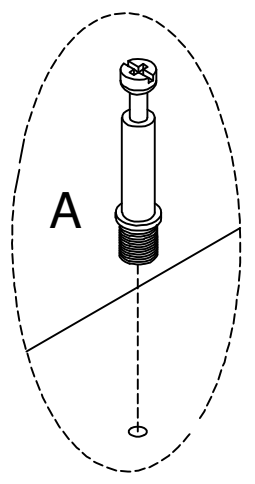

# Step 9

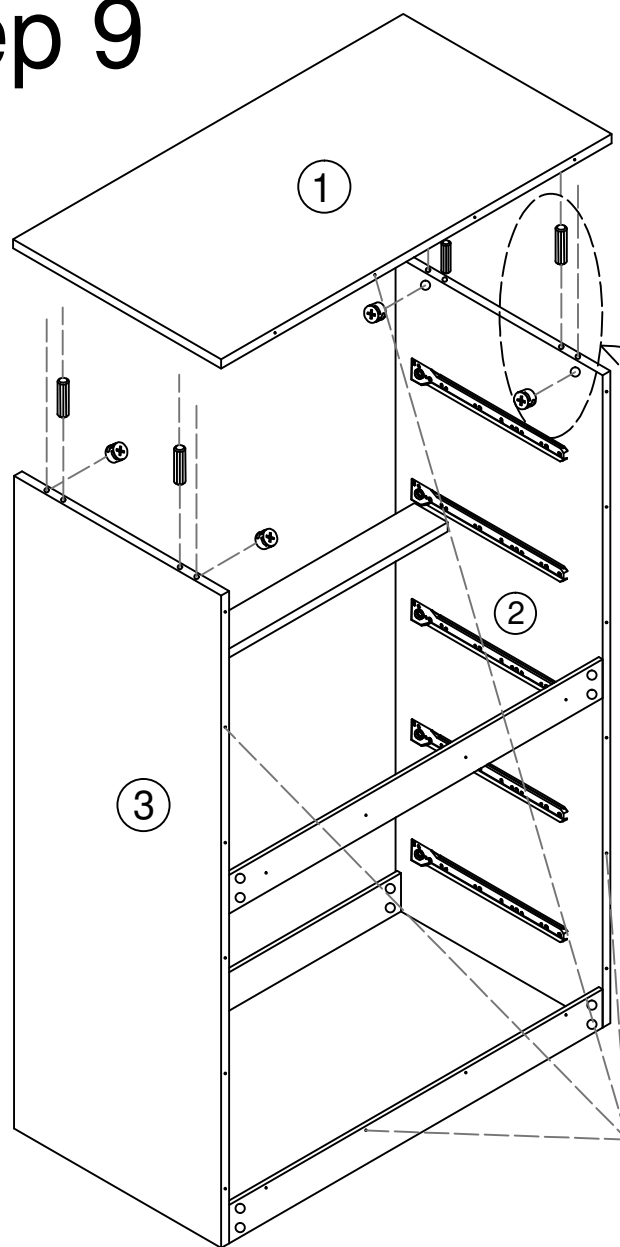

(B) x 4pcs

(M) x 4pcs

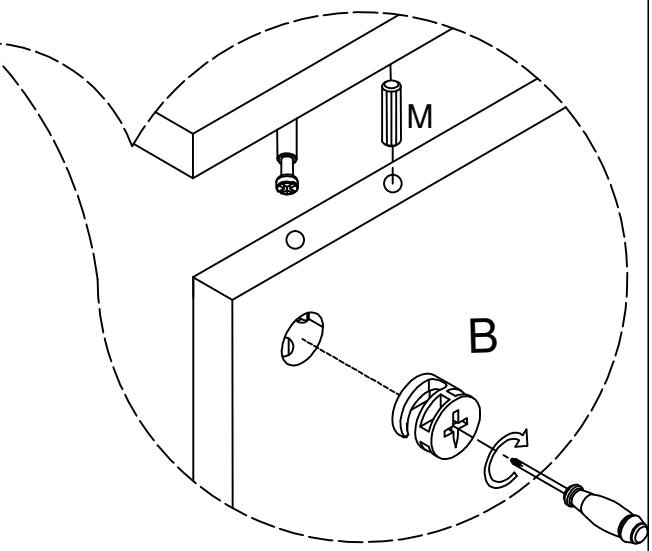

Pay attention to hole location

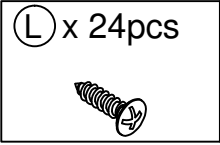

# Step 10

Pay attention to hole location

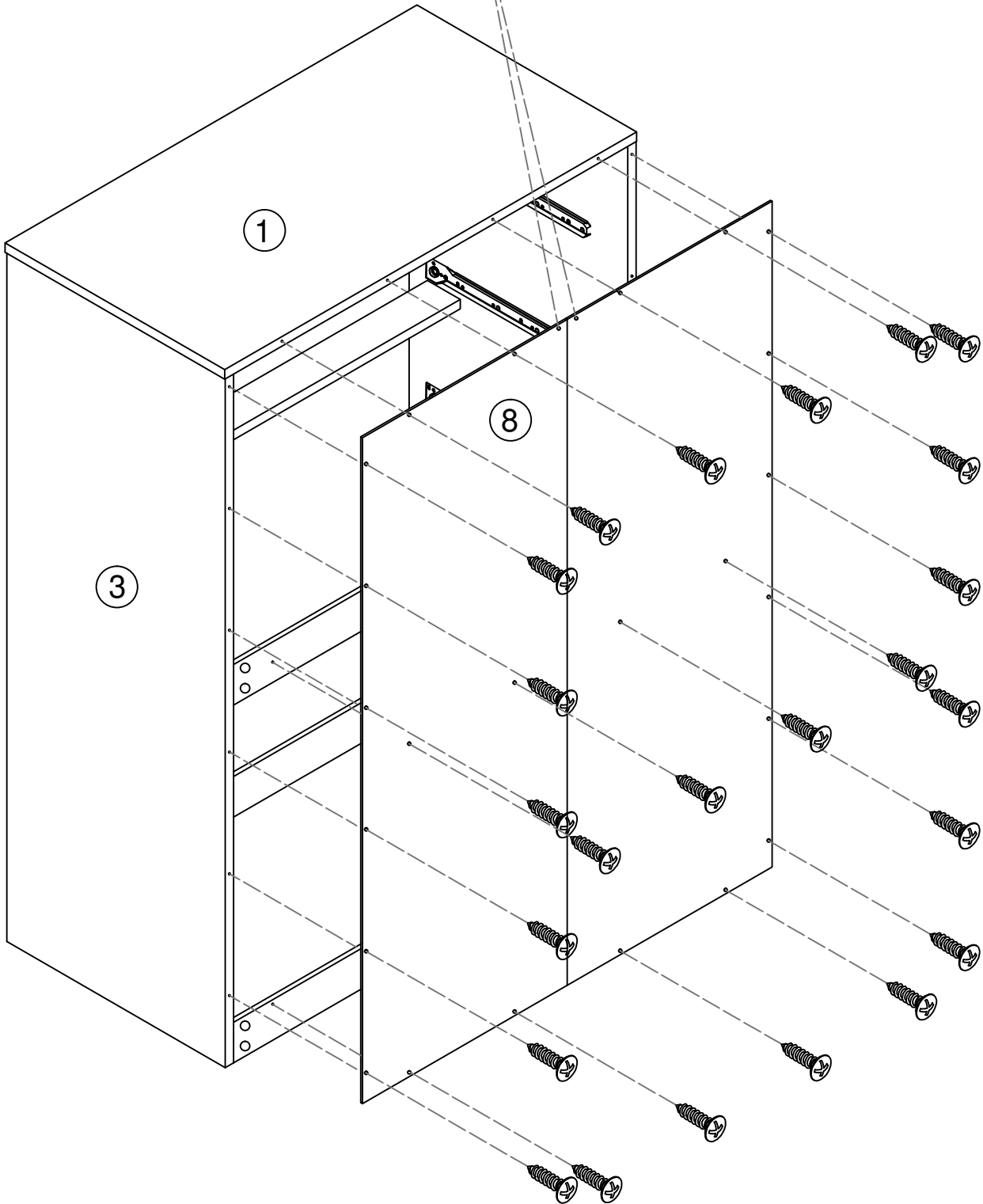

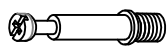

# Step 12

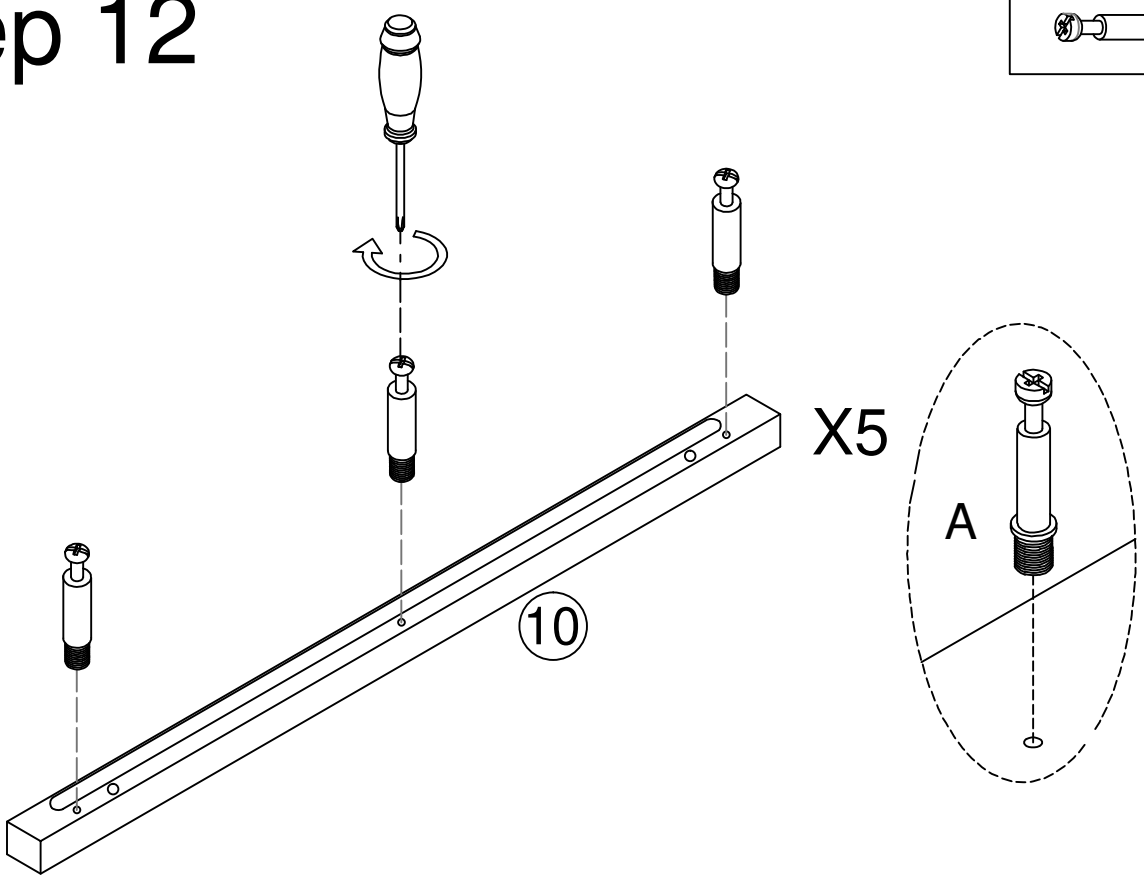
(A) x 15pcs  



# Step 13

(B) x 15pcs  

(M) x 10pcs  

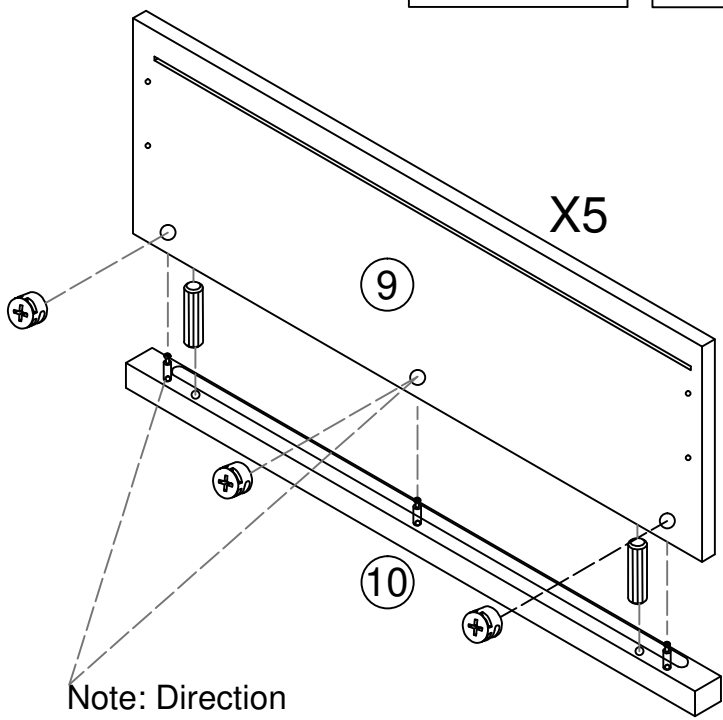
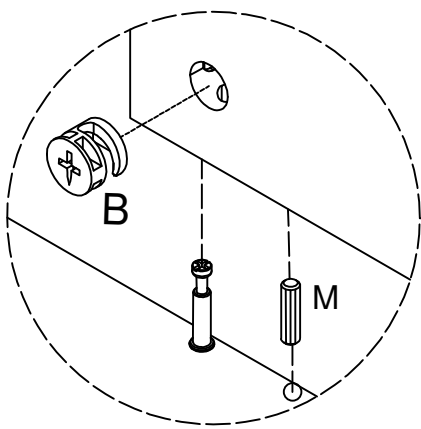

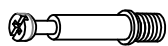

# Step 14

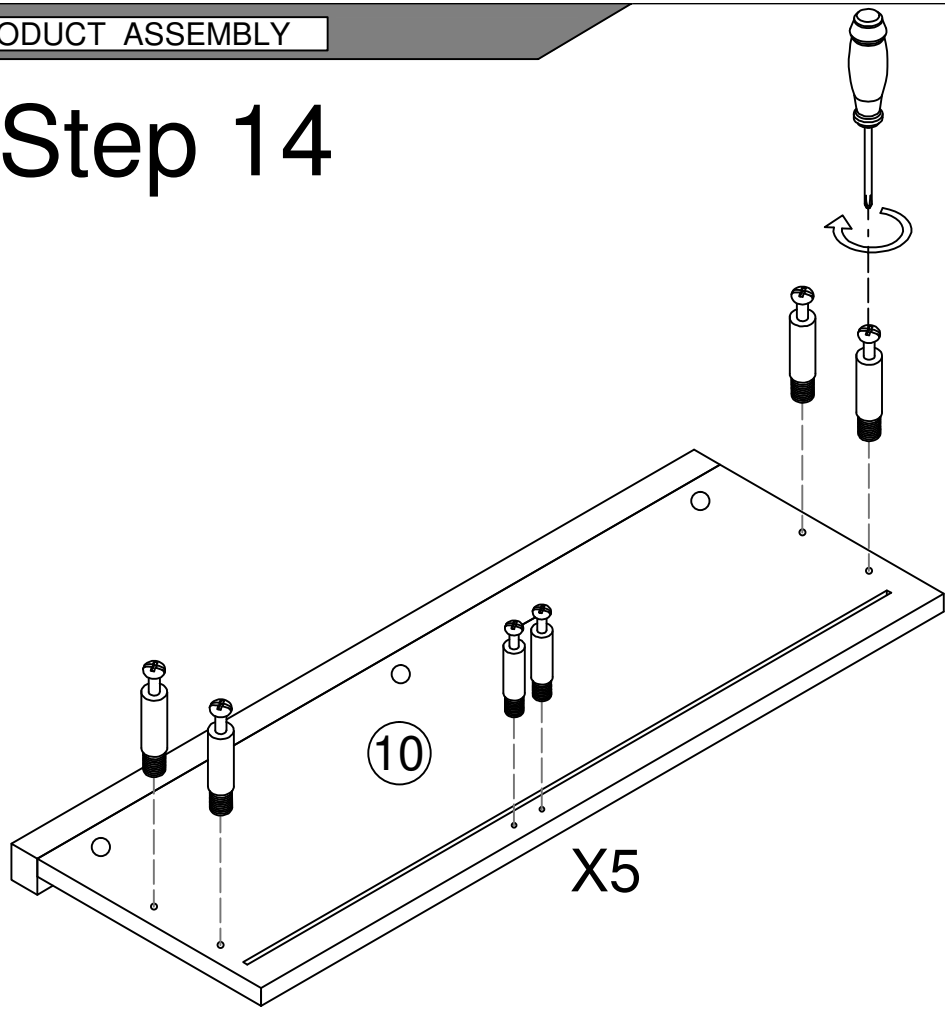
(A) x 30pcs  



# Step 15

(B) x 30pcs  

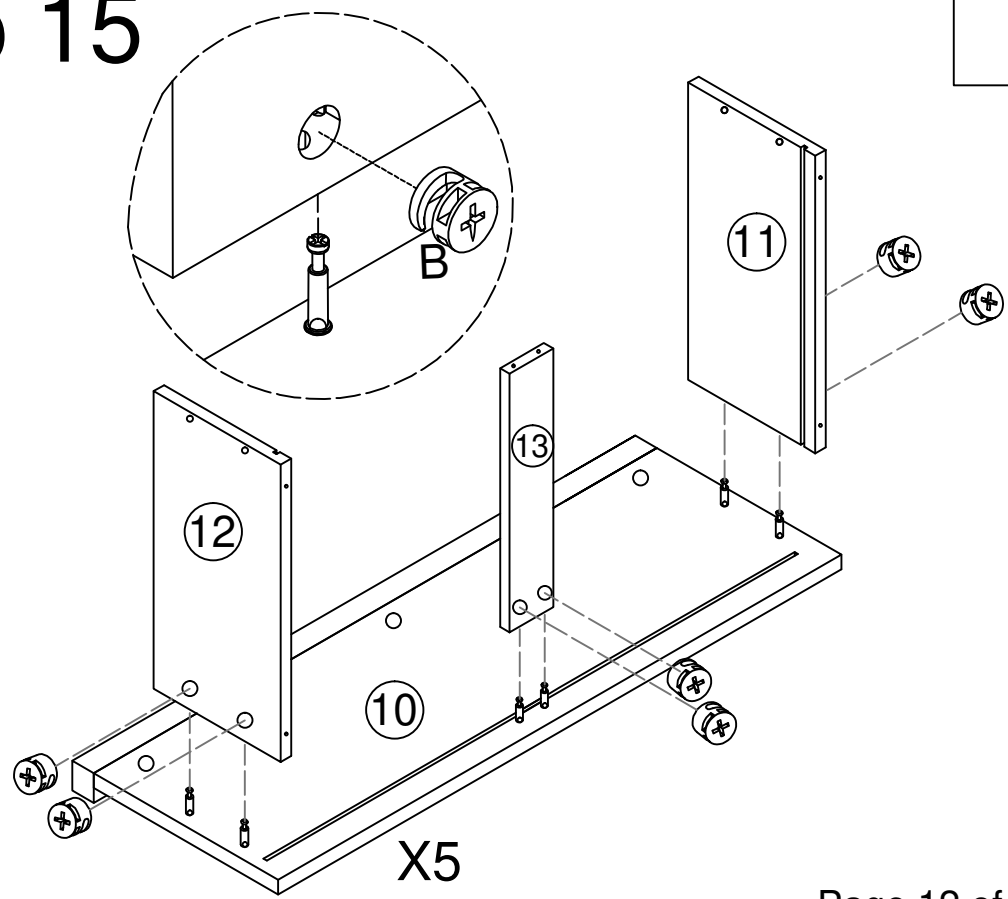

# Step 16

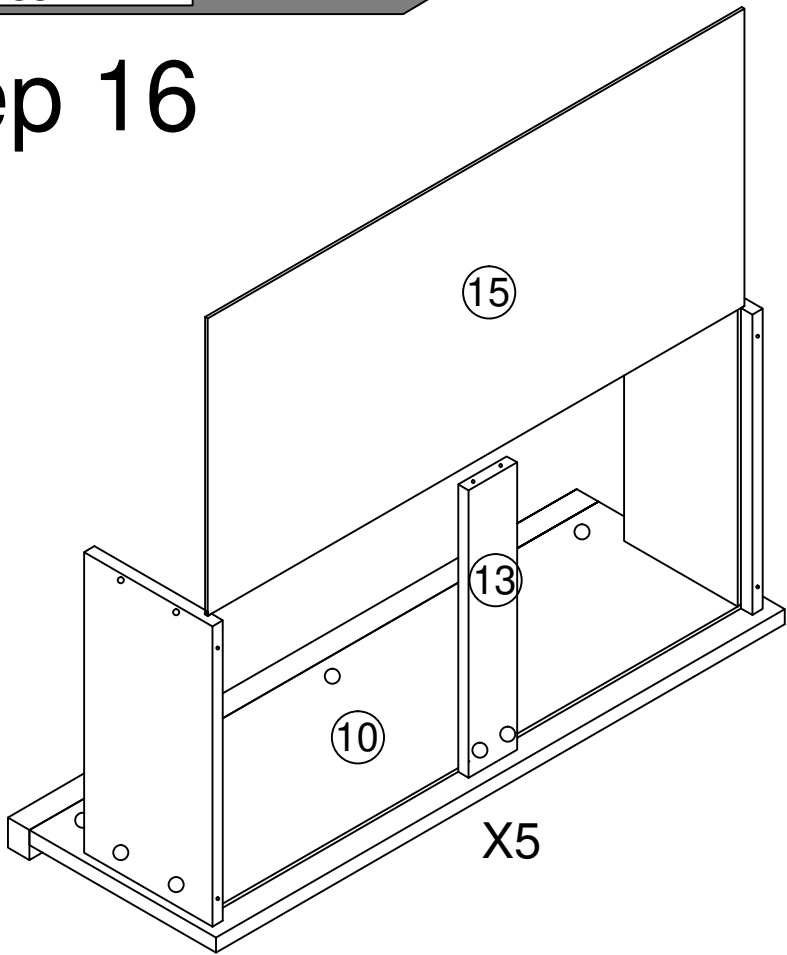

# Step 17

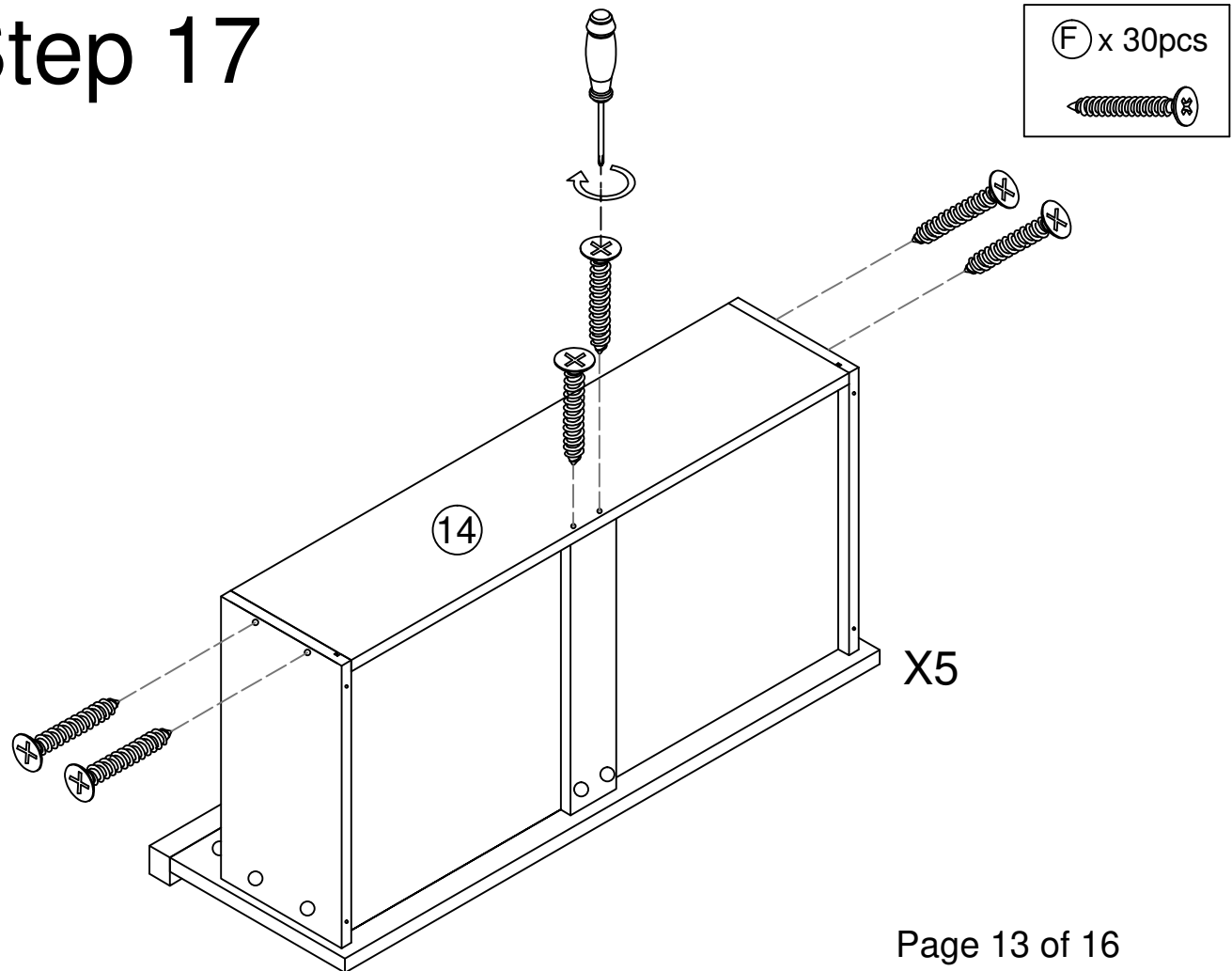

# Step 18

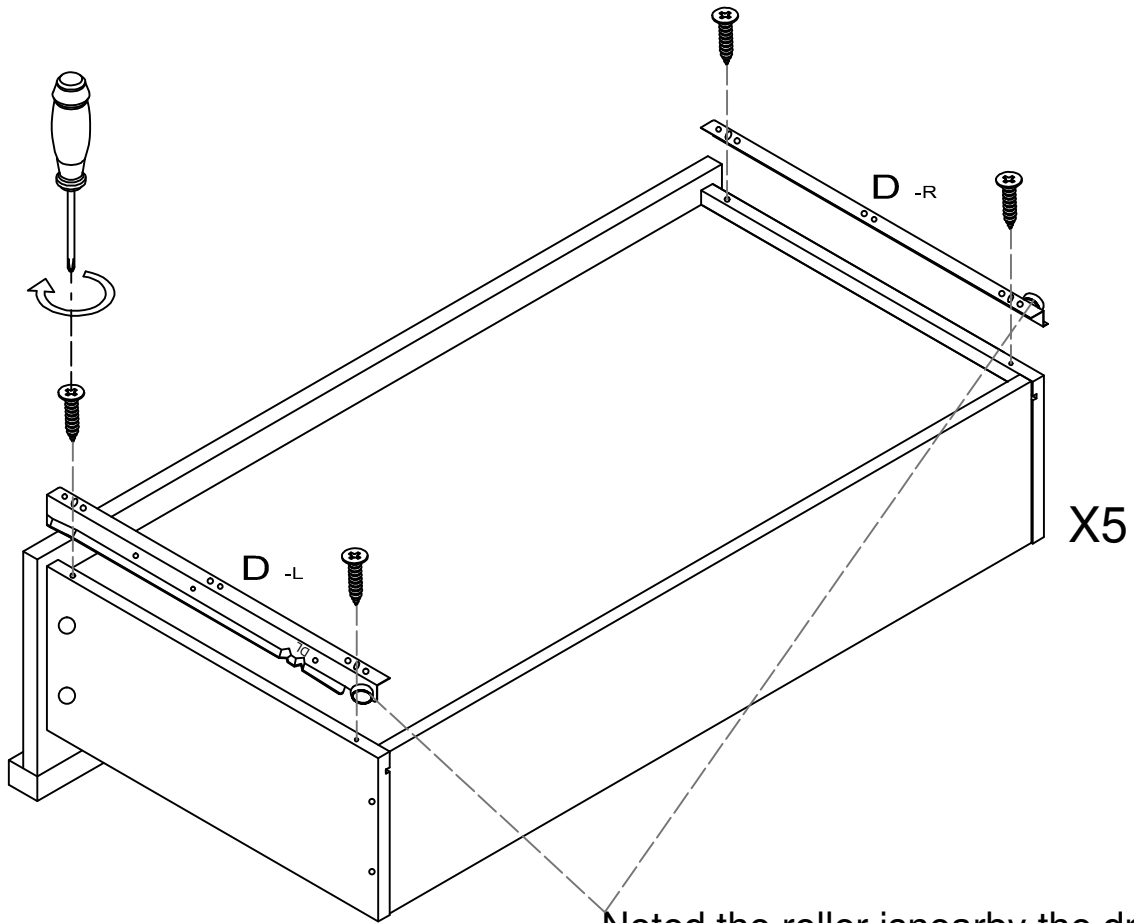
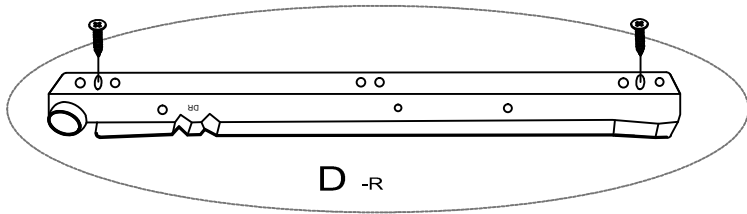
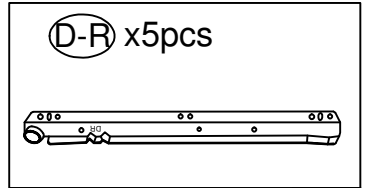
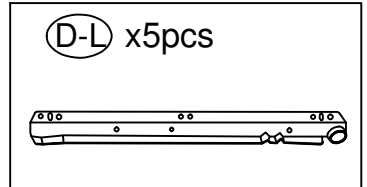
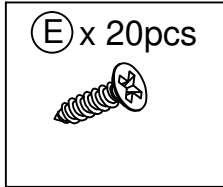

Noted the roller is nearby the drawer end

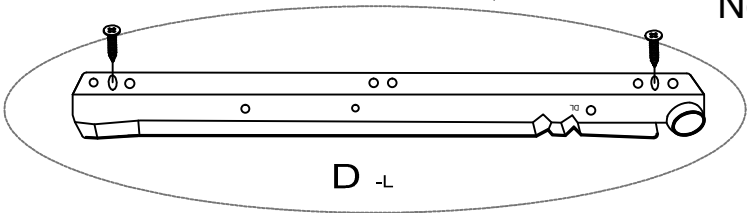

# Step 19

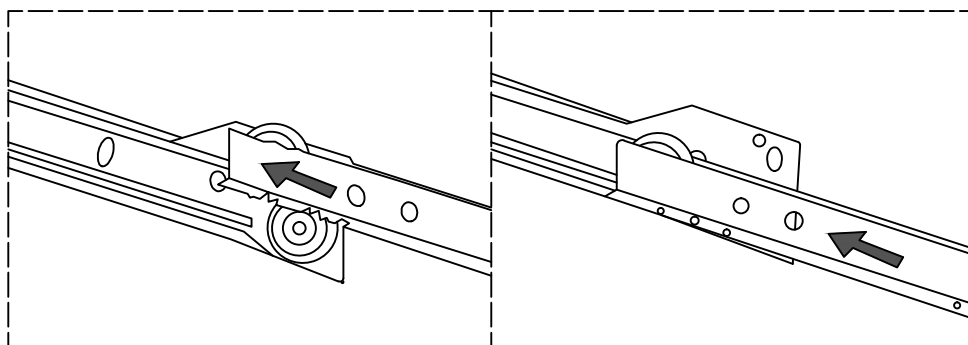
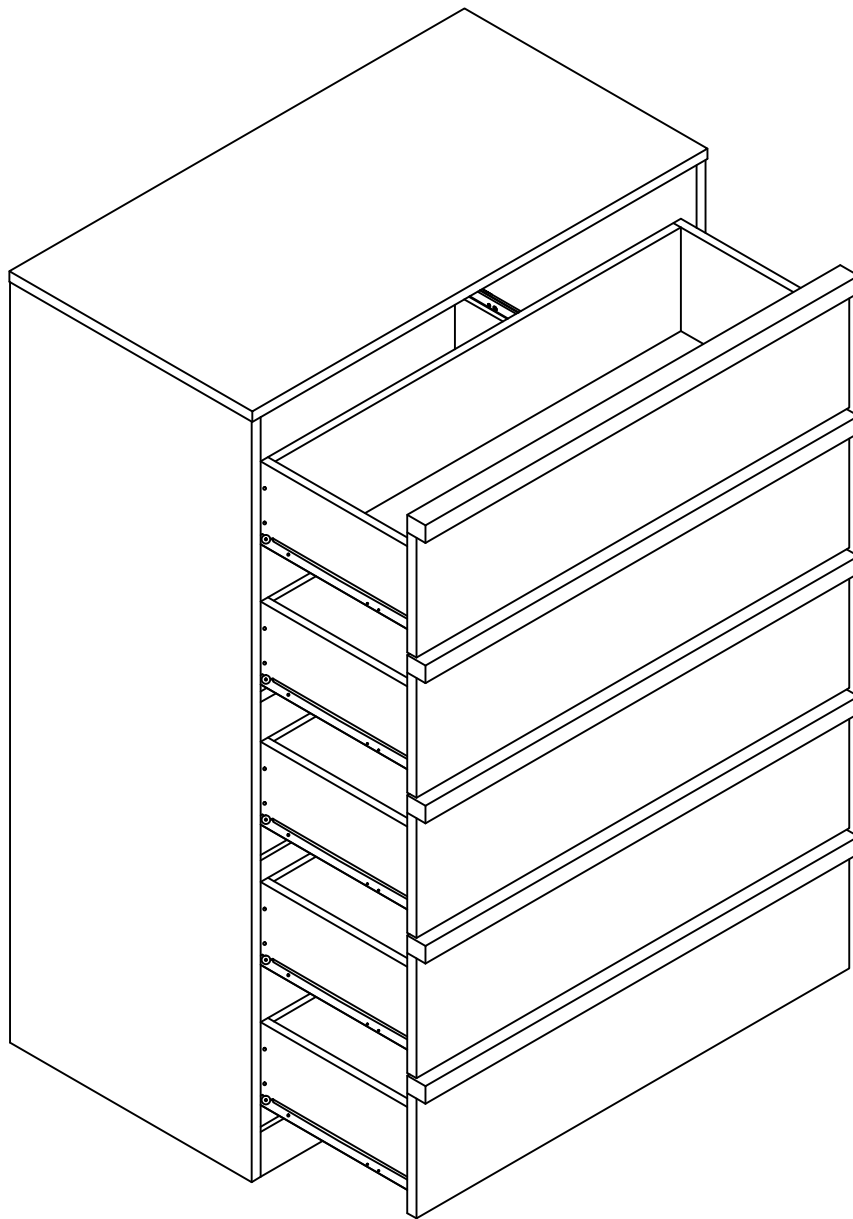

# Step 20

① x1PCS

