

Assembly | Asambllea | Assemblage

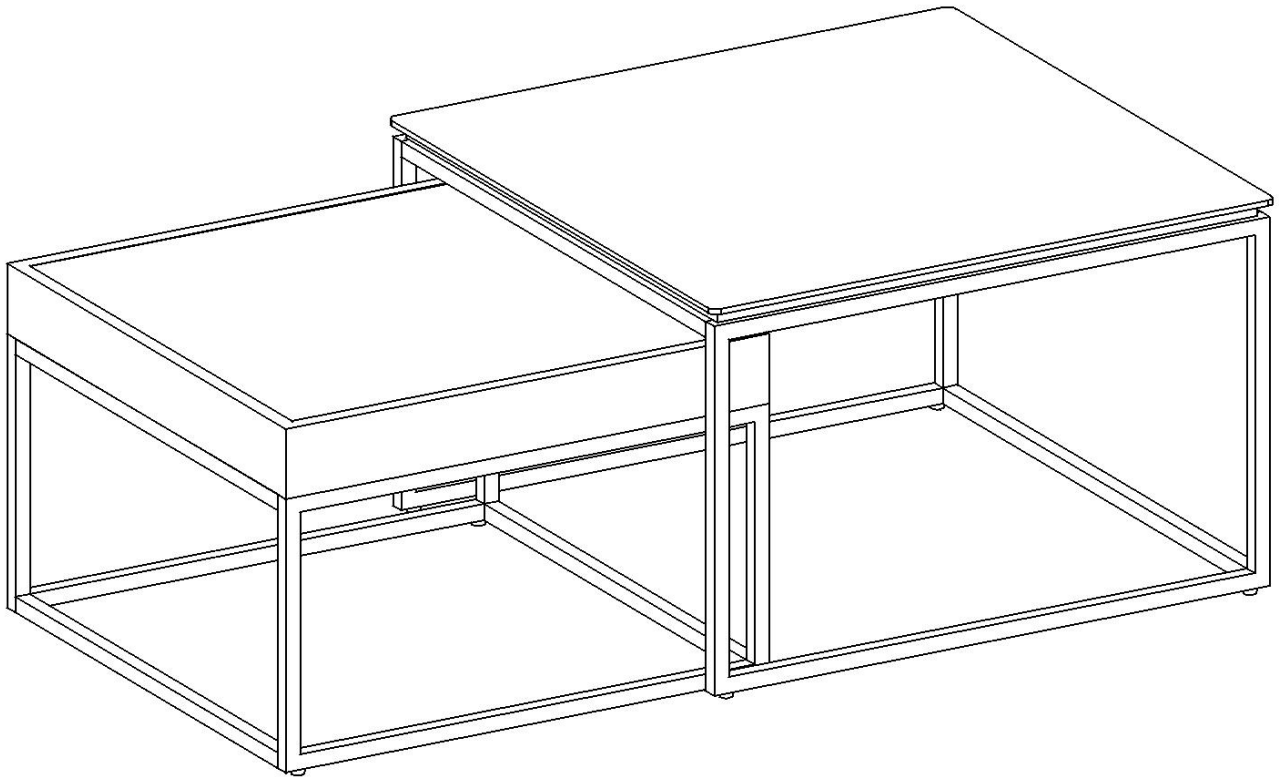

Assembly | Asamblea | Assemblage

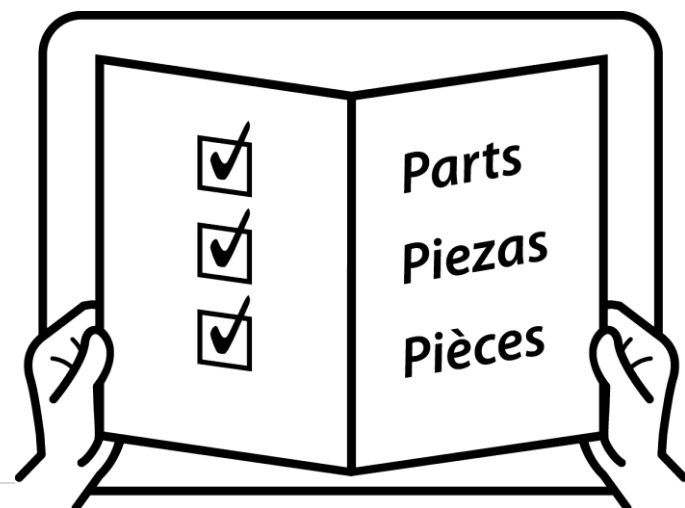
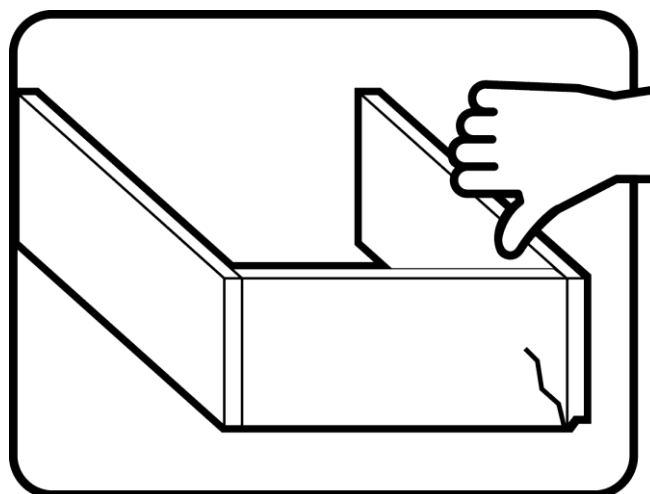
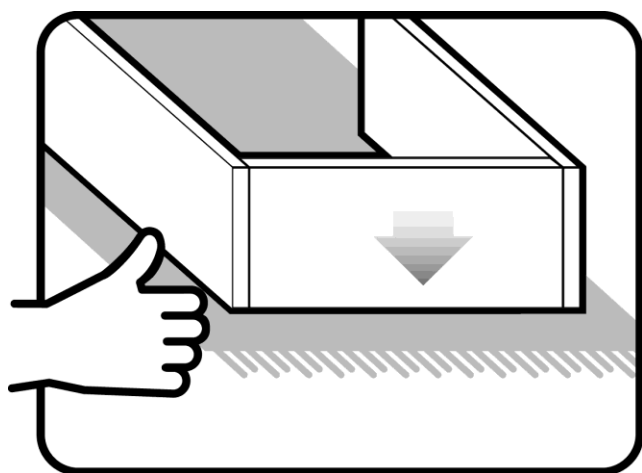
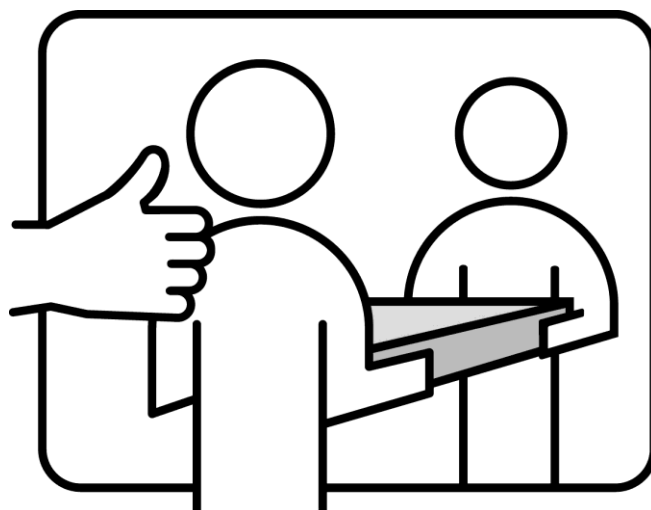
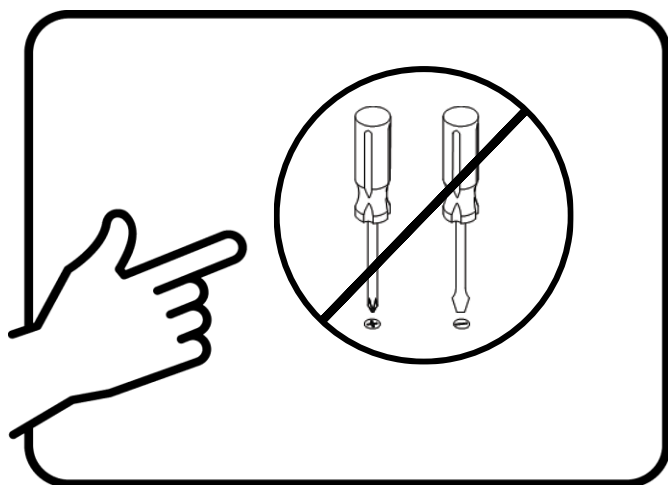

Assembly | Asamblea | Assemblage

Techniques | Técnicas | Techniques

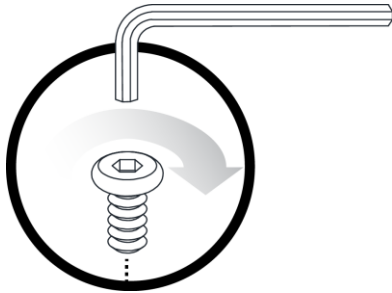

Care | Cuidado | Entretien

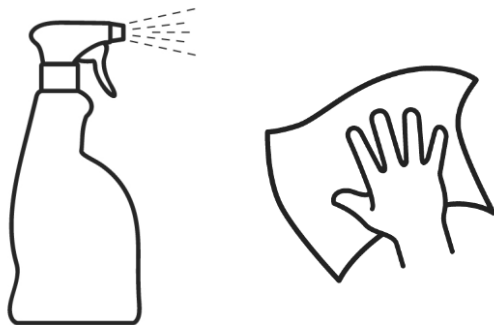



Safety | Seguridad | Sécurité





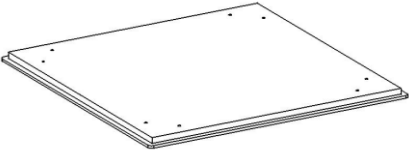
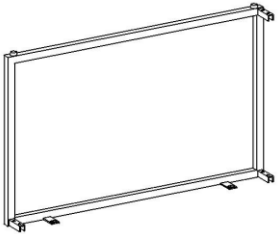
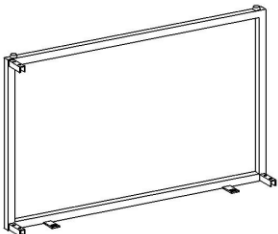

Note! | ¡Nota! | Remarque!

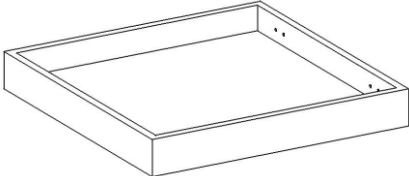
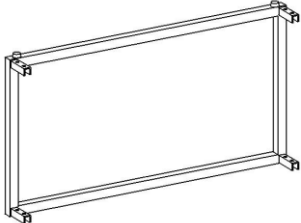
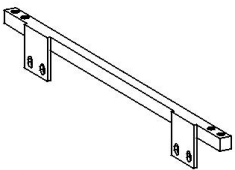
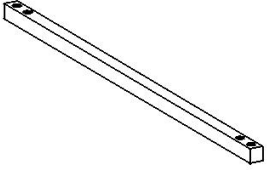

Assembly | Asamlea | Assemblage

<p>A x1</p>  <p>Top frame Marco superior Cadre supérieur</p>	<p>B x1</p>  <p>Leg Pierna Jambe</p>	<p>C x1</p>  <p>Leg Pierna Jambe</p>
<p>D x1</p>  <p>Rail Carril Rail</p>	<p>E x2</p>  <p>Rail Carril Rail</p>	<p>F x1</p>  <p>Top frame Marco superior Cadre supérieur</p>
<p>G x2</p>  <p>Leg Pierna Jambe</p>	<p>H x2</p>  <p>Rail Carril Rail</p>	<p>I x2</p>  <p>Rail Carril Rail</p>

Assembly | Asamblea | Assemblage

<p>1</p> <p>x28</p>  <p>Bolt Tornillo Boulon</p> <p>M6X10MM</p>	<p>2</p> <p>x16</p>  <p>Bolt Tornillo Boulon</p> <p>M6X16MM</p>	<p>3</p> <p>x44</p>  <p>Flat washer Arandela plana Rondelle plate</p> <p>M6</p>
<p>4</p> <p>x1</p>  <p>Allen wrench Llave Allen Clé Allen</p> <p>M4</p>		

Assembly | Asambllea | Assemblage

Big Table Assembly

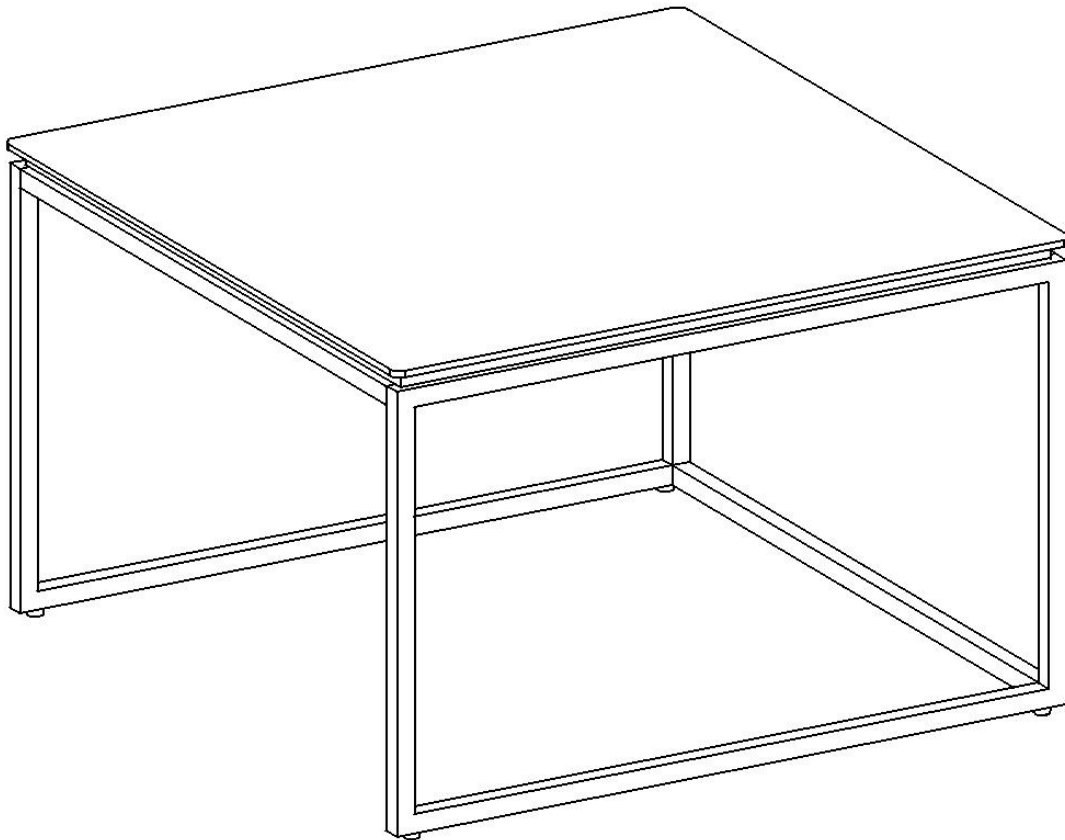

Assembly | Asambla | Assemblage

B_(x1)

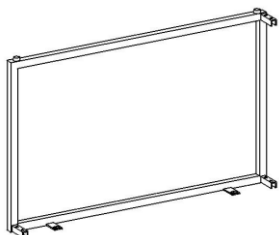

C_(x1)

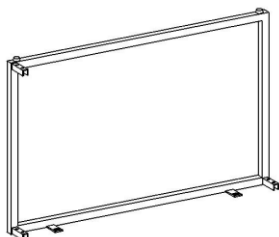

D_(x1)



E_(x2)

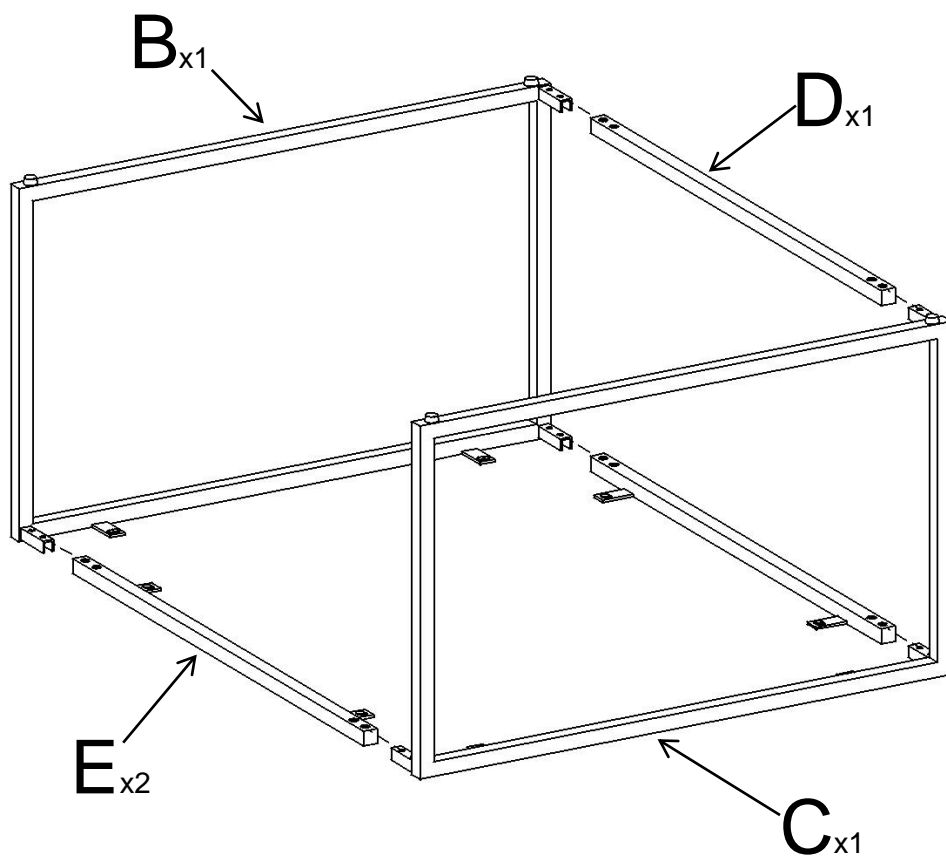

Do not fully tighten screws until all screws are in position.

No apriete completamente los tornillos hasta que estén en su posición.

Ne serrez pas complètement les vis tant que toutes les vis ne sont pas en place.

Assembly | Asambla | Assemblage

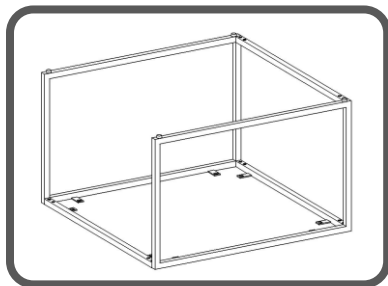

1 (x12)



3 (x12)



4 (x1)

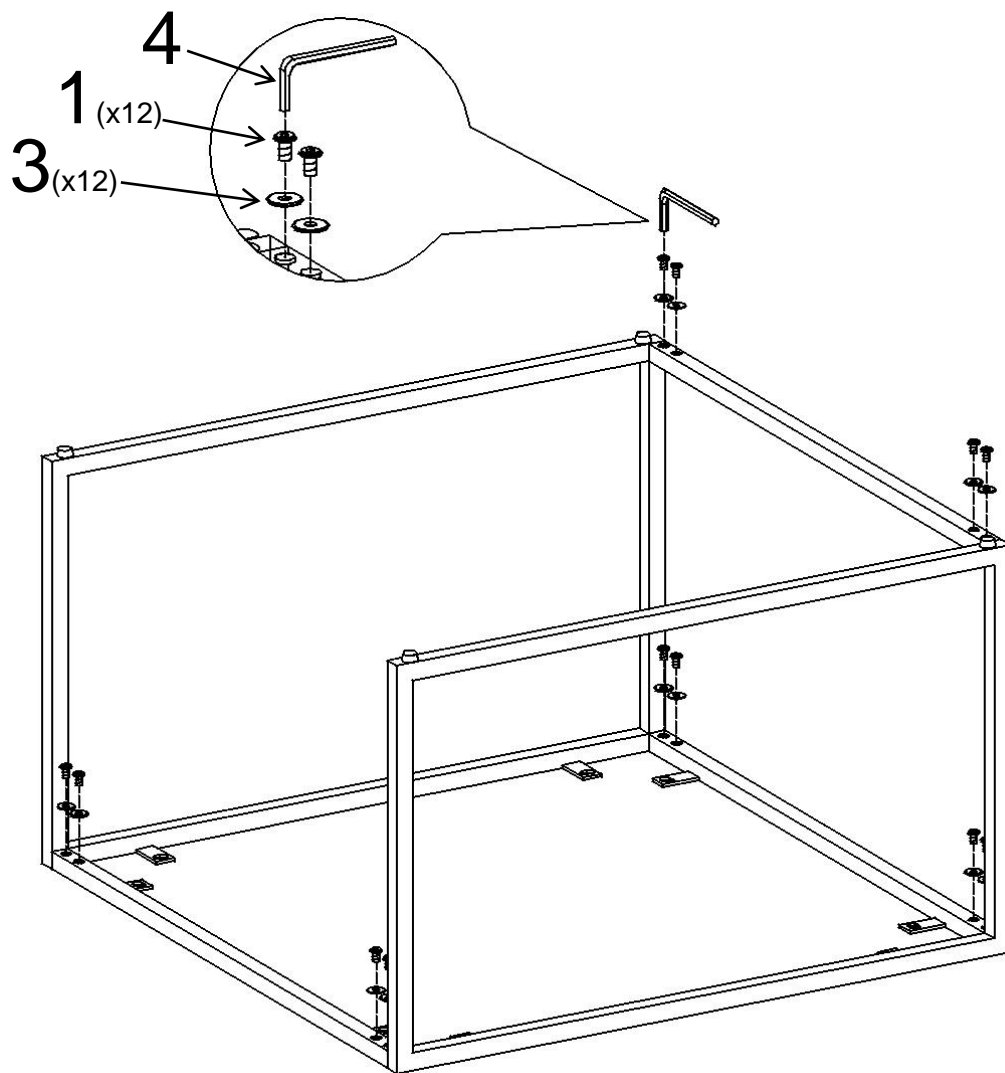

Assembly | Asambla | Assemblage

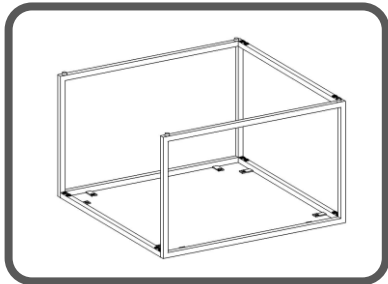

A(x1)

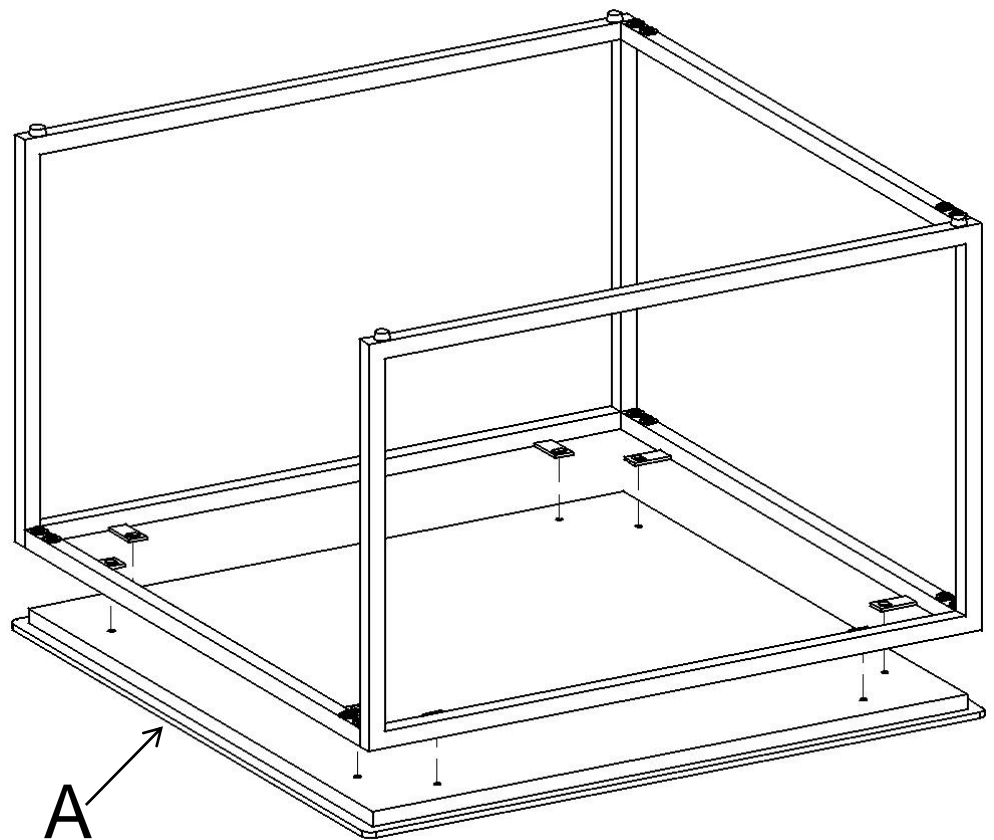
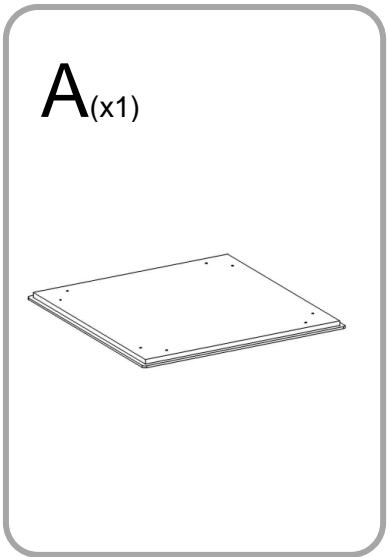

Tighten all screws.

Apretar todos los tornillos.

Serrez toutes les vis.

Assembly | Asambla | Assemblage

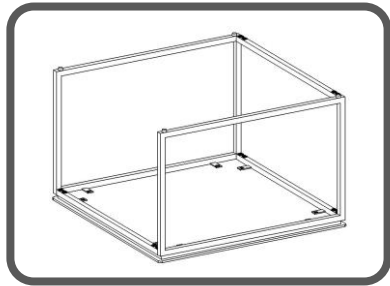

2(x8)



3(x8)



4(x1)

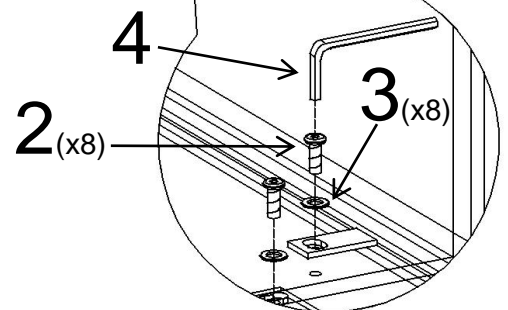
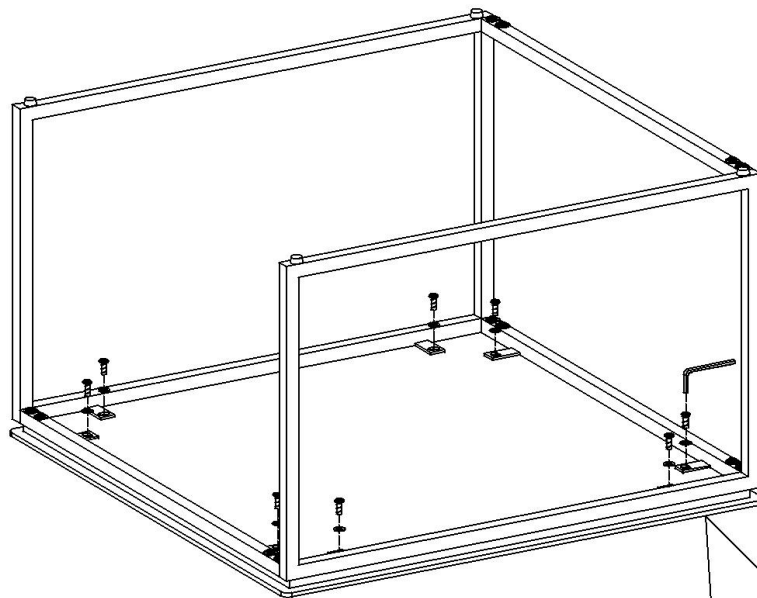

Assembly | Asamblea | Assemblage

Small Table assembly

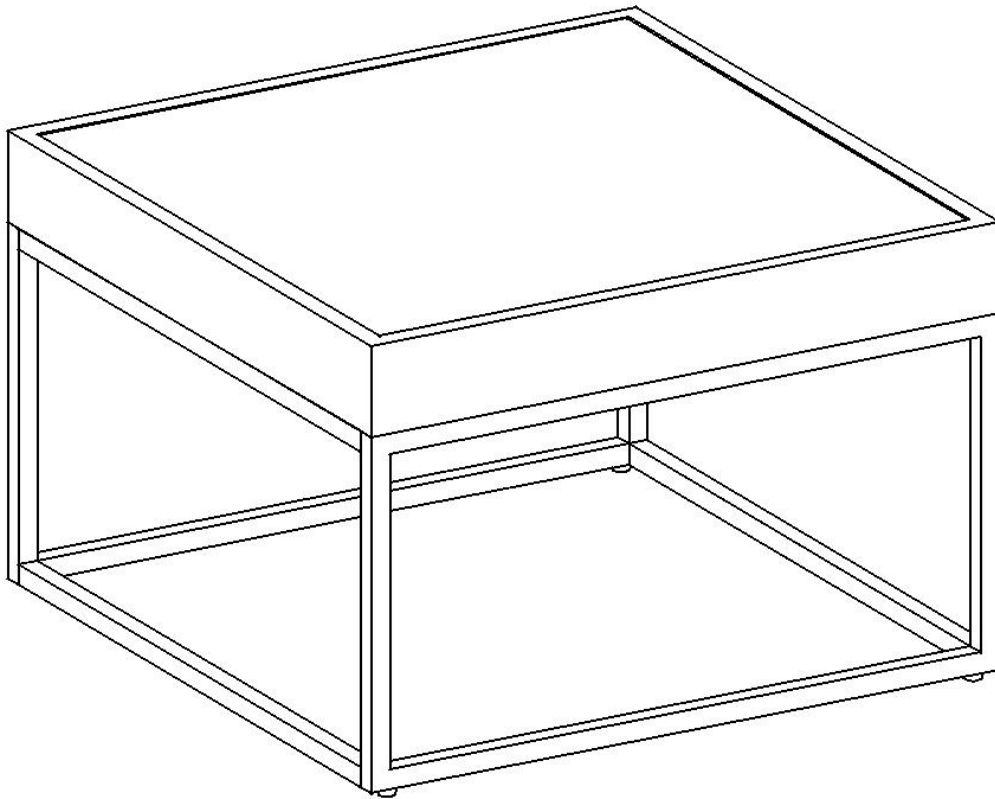

Assembly | Asambla | Assemblage

G_(x2)

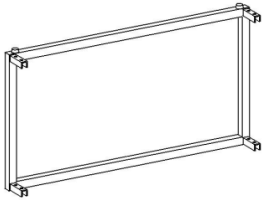

H_(x2)

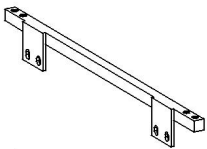

I_(x2)

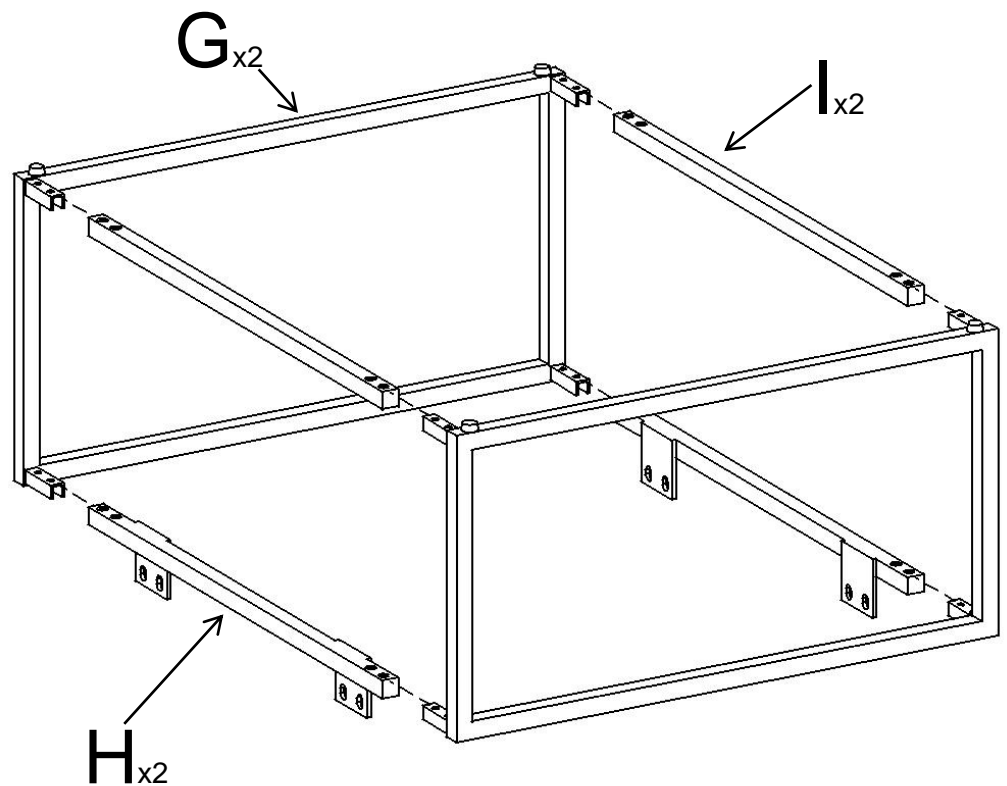
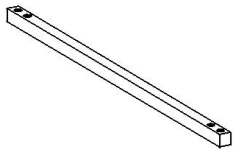

Do not fully tighten screws until all screws are in position.

No apriete completamente los tornillos hasta que estén en su posición.

Ne serrez pas complètement les vis tant que toutes les vis ne sont pas en place.

Assembly | Asambla | Assemblage

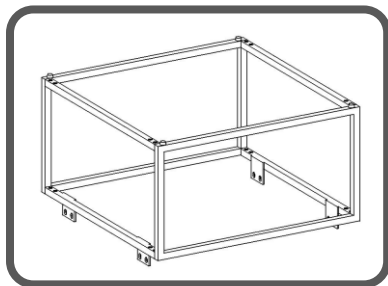

1 (x16)



3 (x16)



4 (x1)

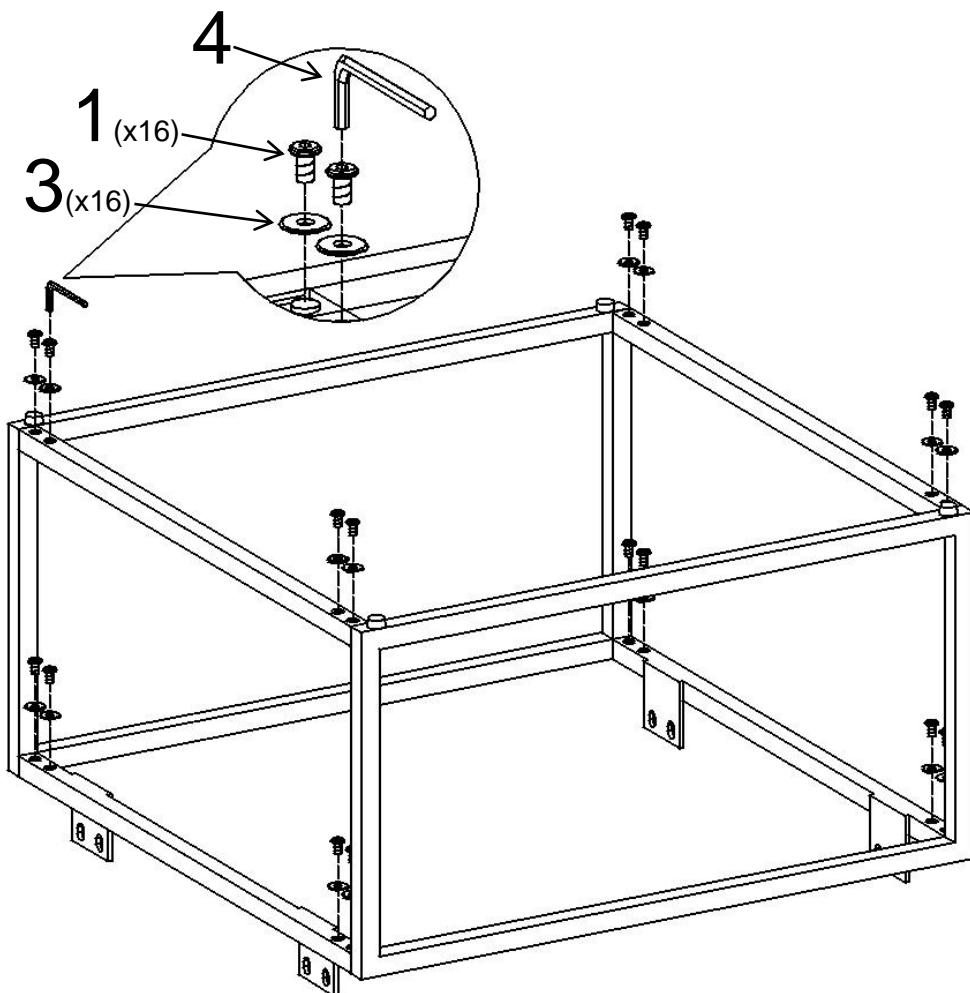

Assembly | Asambla | Assemblage

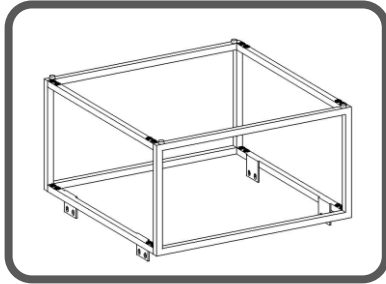

F (x1)

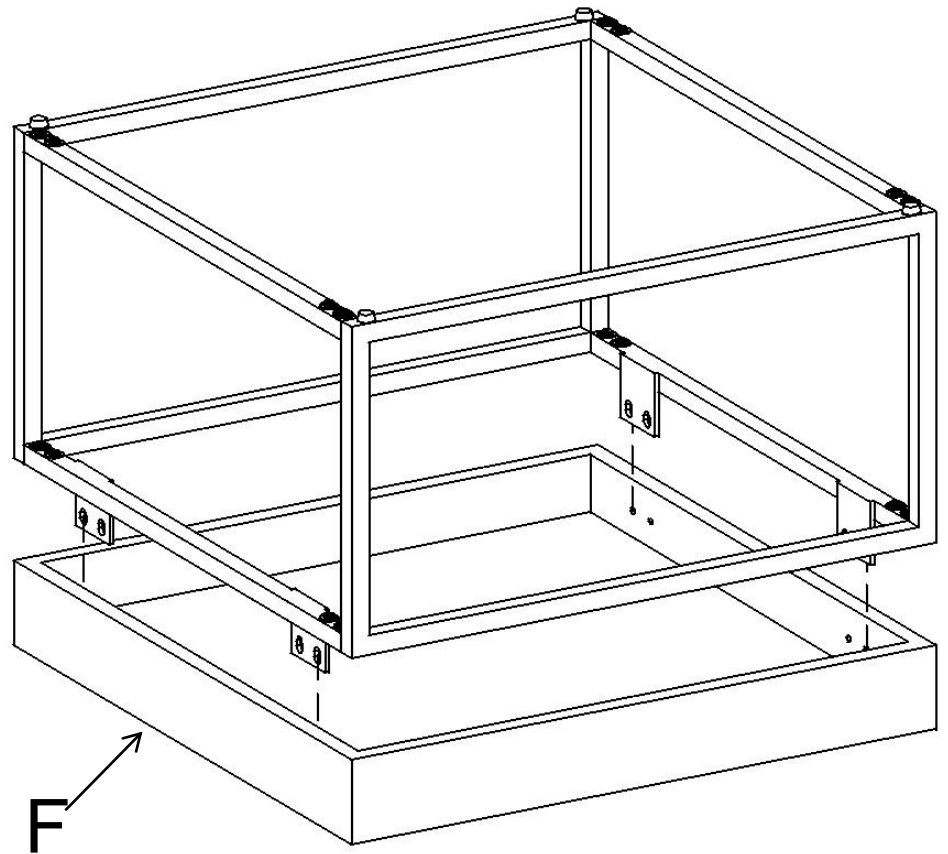
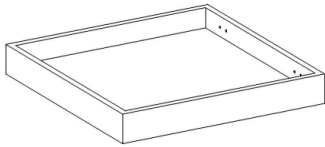

Tighten all screws.

Apretar todos los tornillos.

Serrez toutes les vis.

Assembly | Asambla | Assemblage

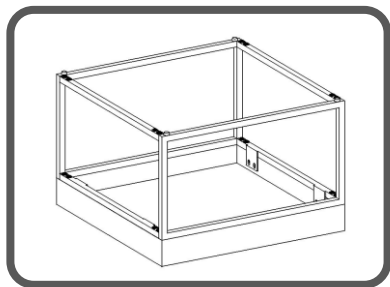

2_(x8)



3_(x8)



4_(x1)

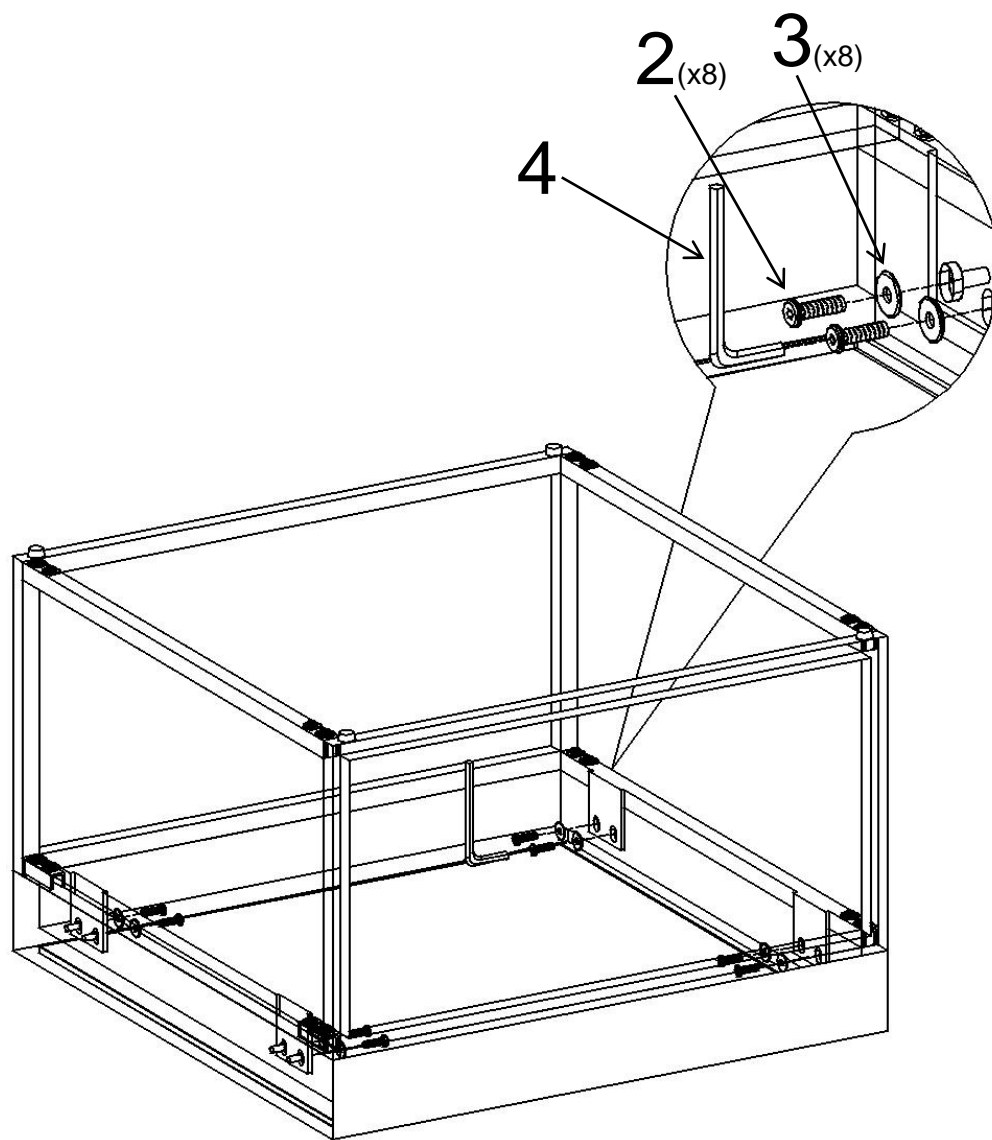

Assembly | Asambllea | Assemblage

