

Helpful Hints

1. We recommend two people to assemble the product easier and faster.
2. Please DO NOT tighten the screws deeply during assembling avoiding that metal frame can be bent and plank will crack.
3. We recommend that all screws should not be tightened over during assembling to make it easy to adjust. When it is adjusted to proper station all screws should be tightened.
4. Caution: If using a power drill or power screwdriver for screwing, please be aware of to slow down and stop when screw is tight. Failure to do so may result in stripping the screw.

Customer Service

As this item contains many parts, please read the installation instruction carefully before installation and complete the installation with the cooperation of your partner. Please use tools properly and carefully. If you have any questions about the product and installation,

Exploded Drawing

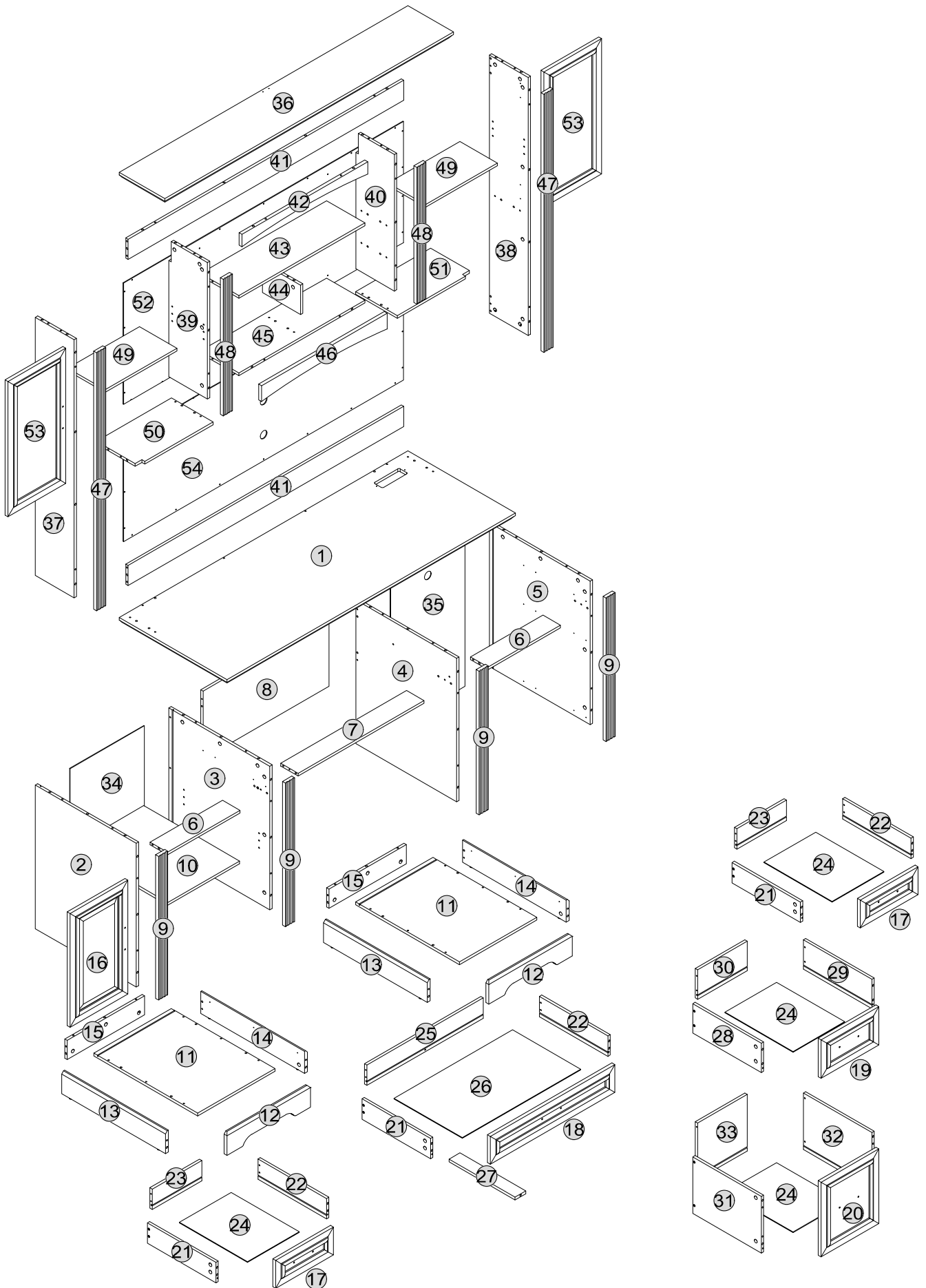

Parts

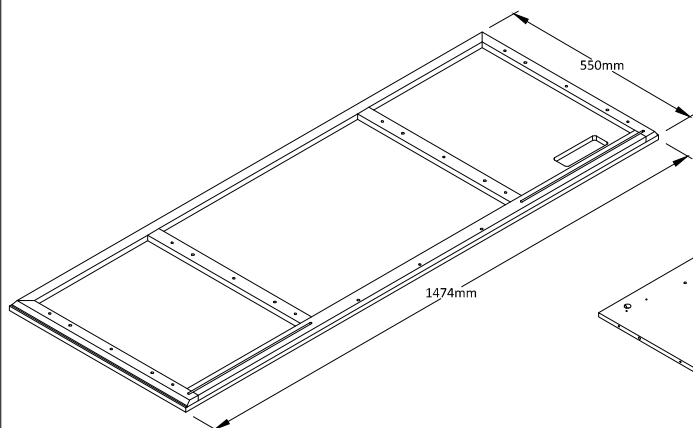

①

DESK TOP
Qty:1

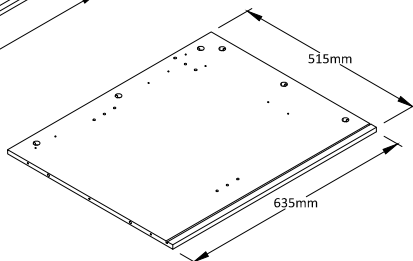

②

LEFT PANEL
Qty:1

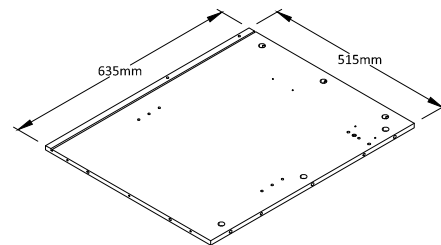

③

LEFT PARTITION
Qty:1

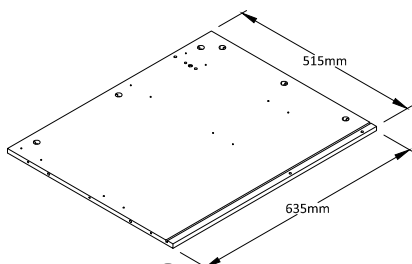

④

RIGHT PARTITION
Qty:1

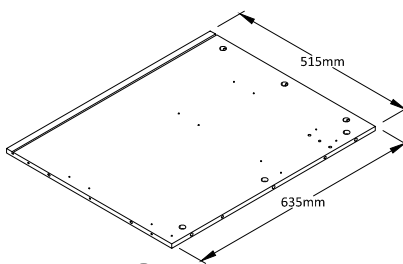

⑤

RIGHT PANEL
Qty:1

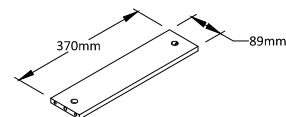

⑥

SIDE RAIL
Qty:2

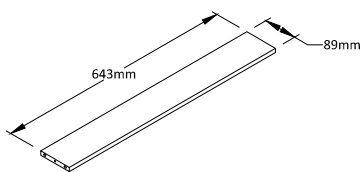

⑦

FRONT RAIL
Qty:1

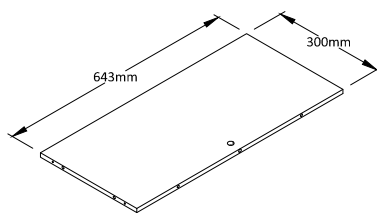

⑧

BACK PANEL
Qty:1

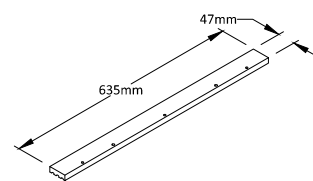

⑨

RAIL
Qty:4

Parts

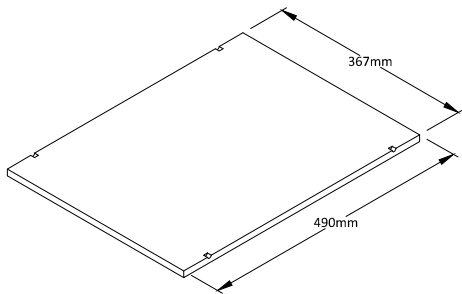

10

ADJUSTABLE SHELF
Qty:1

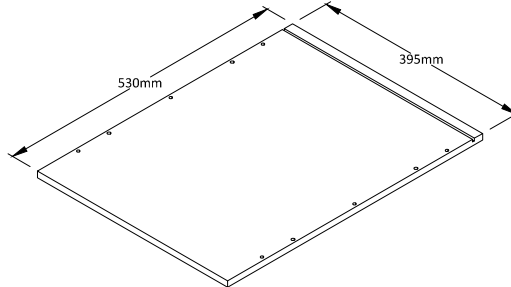

11

BOTTOM
Qty:2

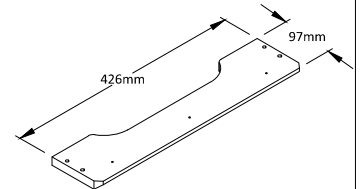

12

BOTTOM FRONT APRON
Qty:2

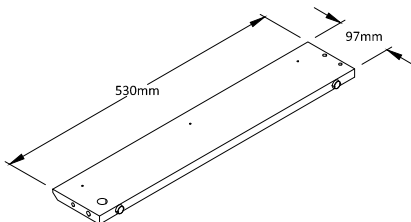

13

BOTTOM SIDE APRON, LEFT
Qty:2

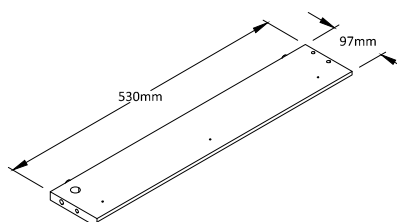

14

BOTTOM SIDE APRON, RIGHT
Qty:2

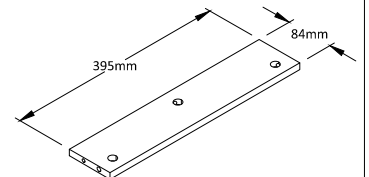

15

BOTTOM BACK APRON
Qty:2

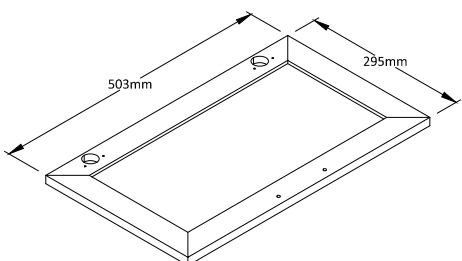

16

LOWER DOOR
Qty:1

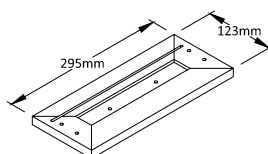

17

DRAWER FRONT
Qty:2

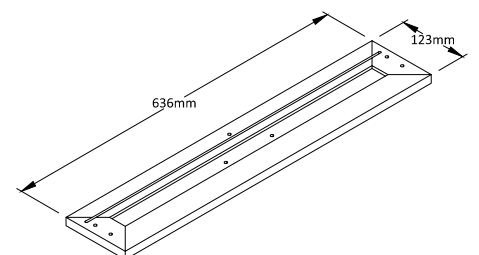

18

DRAWER FRONT
Qty:1

Parts

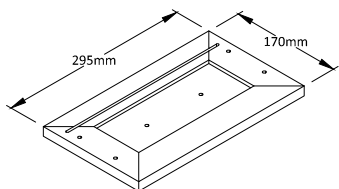

19

DRAWER FRONT
Qty:1

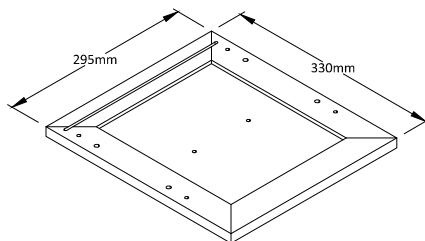

20

DRAWER FRONT
Qty:1

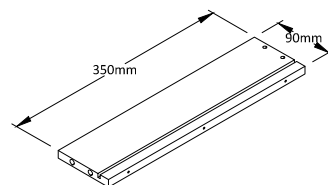

21

LEFT DRAWER SIDE
Qty:3

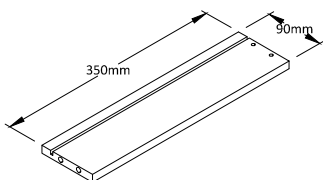

22

RIGHT DRAWER SIDE
Qty:3

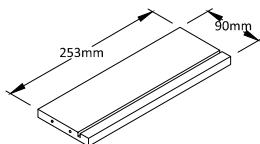

23

DRAWER BACK
Qty:2

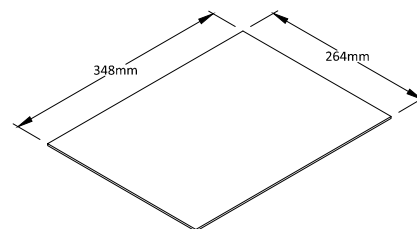

24

DRAWER BOTTOM
Qty:4

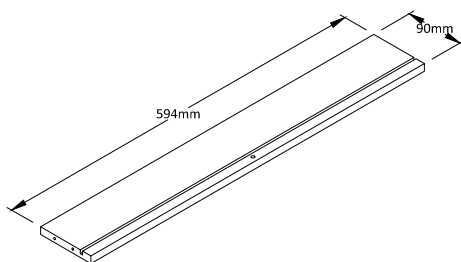

25

DRAWER BACK
Qty:1

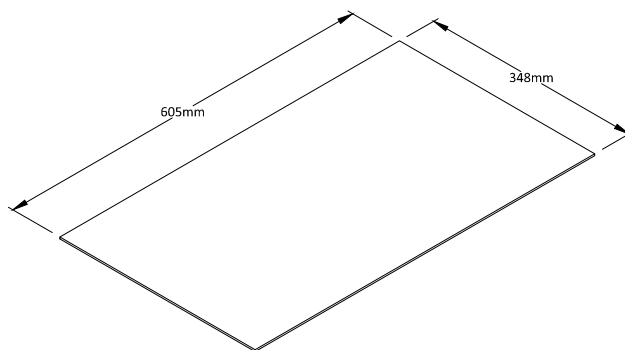

26

DRAWER BOTTOM
Qty:1

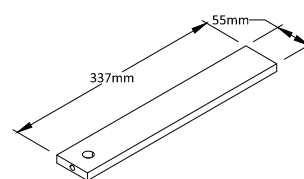

27

DRAWER SUPPORT
Qty:1

Parts

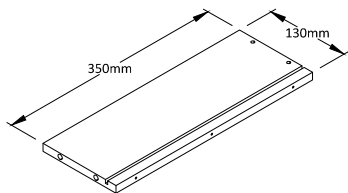

28

LEFT DRAWER SIDE
Qty:1

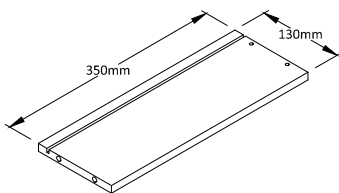

29

RIGHT DRAWER SIDE
Qty:1

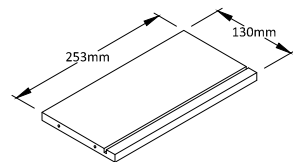

30

DRAWER BACK
Qty:1

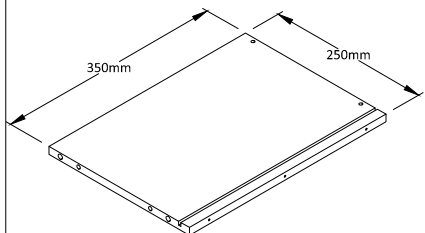

31

LEFT DRAWER SIDE
Qty:1

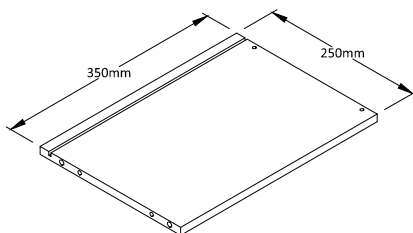

32

RIGHT DRAWER SIDE
Qty:1

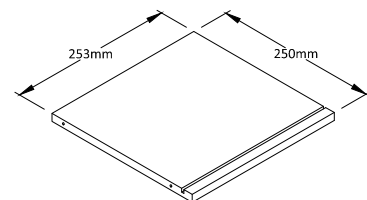

33

DRAWER BACK
Qty:1

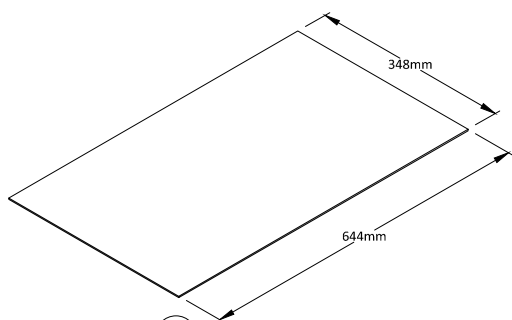

34

BACK PANEL
Qty:1

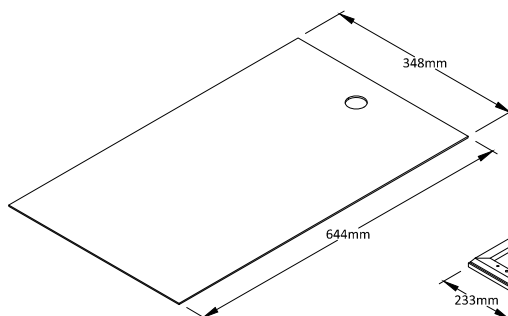

35

BACK PANEL
Qty:1

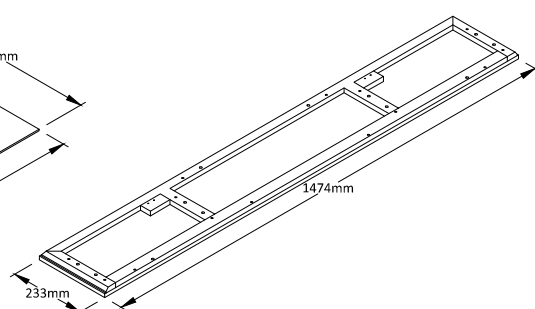

36

TOP
Qty:1

Parts

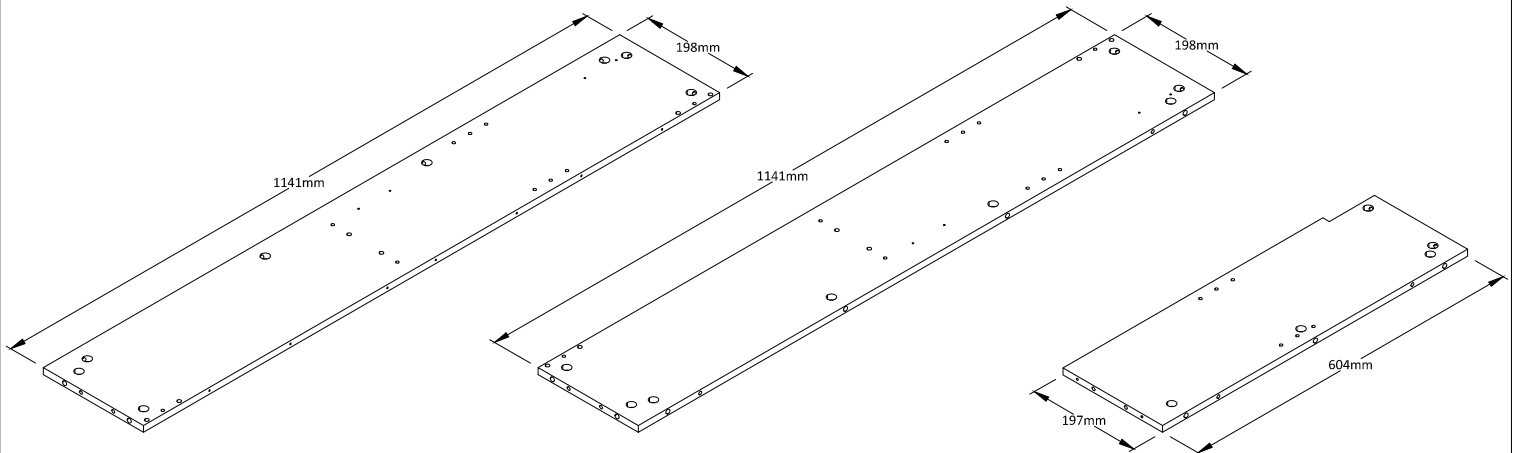

37

UPPER LEFT PANEL
Qty:1

38

UPPER RIGHT PANEL
Qty:1

39

UPPER LEFT PARTITION
Qty:1

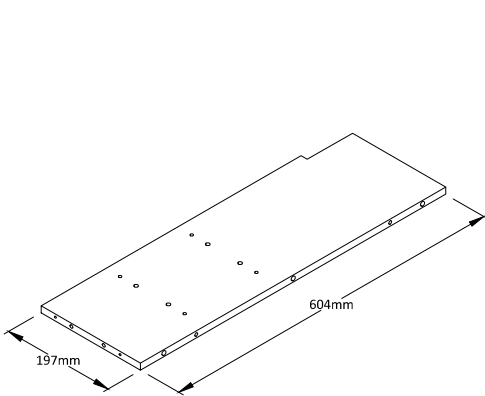

40

UPPER RIGHT PARTITION
Qty:1

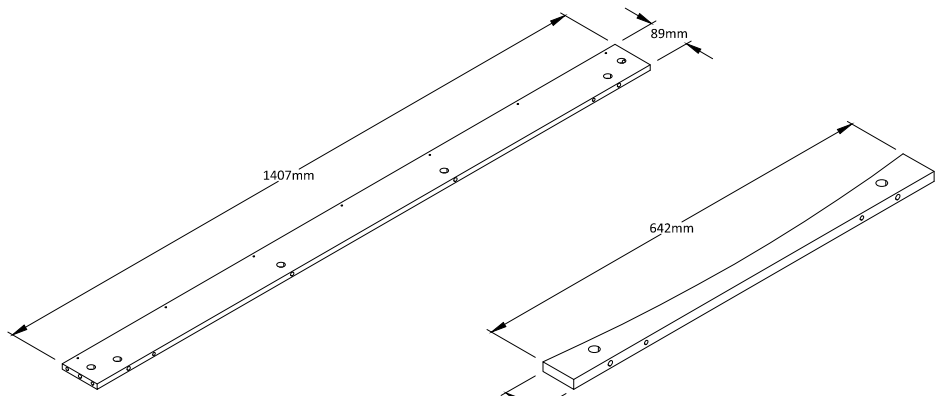

41

BACK RAIL
Qty:2

42

RAIL
Qty:1

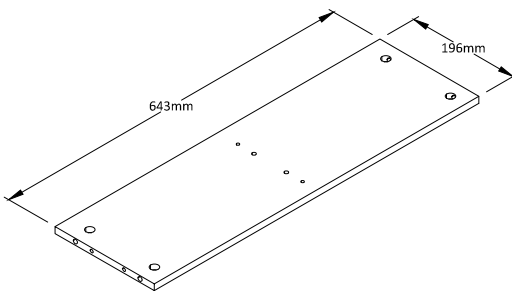

43

FIXED SHELF
Qty:1

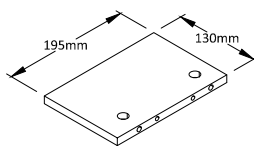

44

PARTITION
Qty:1

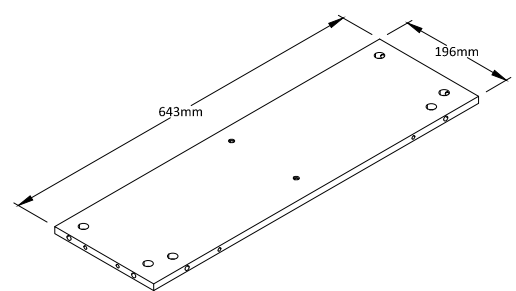

45

FIXED SHELF
Qty:1

Parts

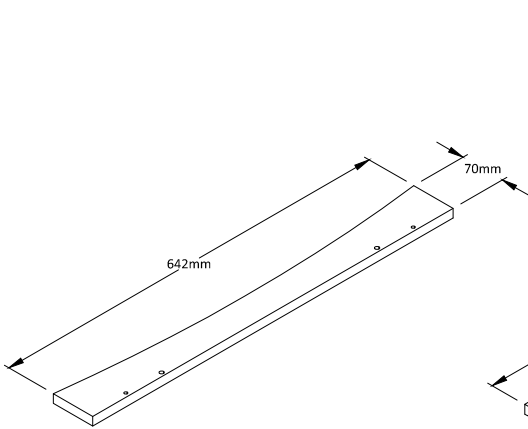

46
RAIL
Qty:1

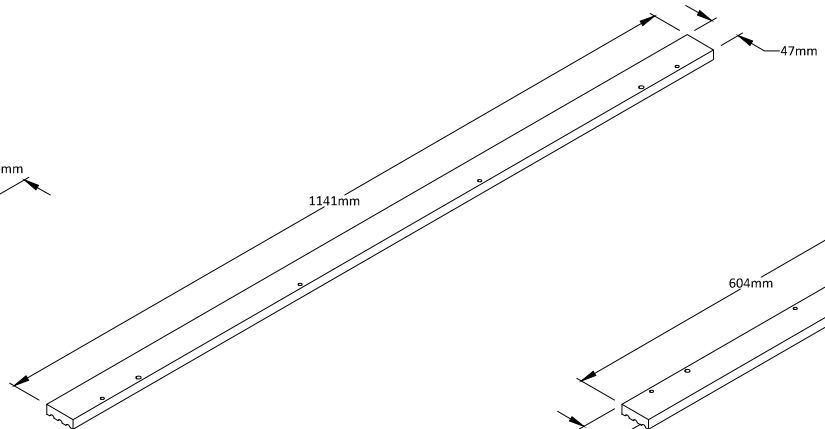

47
UPPER RAIL
Qty:2

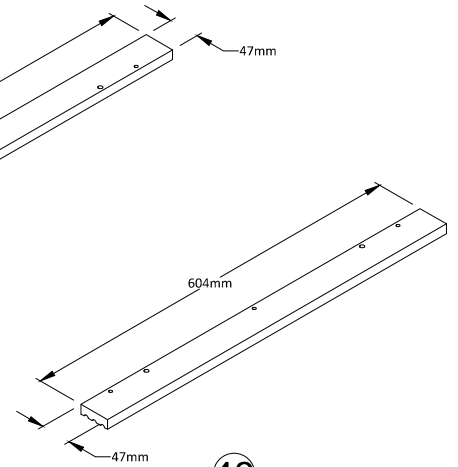

48
UPPER RAIL
Qty:2

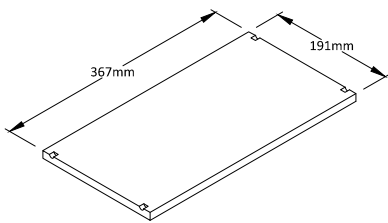

49
ADJUSTABLE SHELF
Qty:2

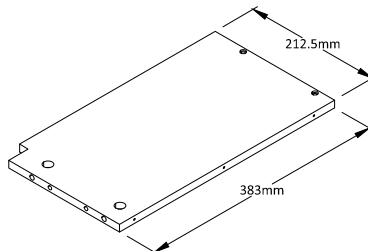

50
UPPER LEFT BOTTOM
Qty:1

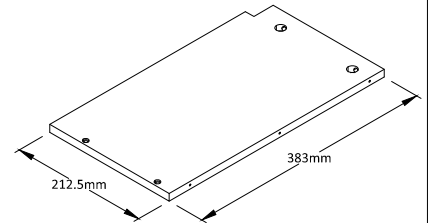

51
UPPER RIGHT BOTTOM
Qty:1

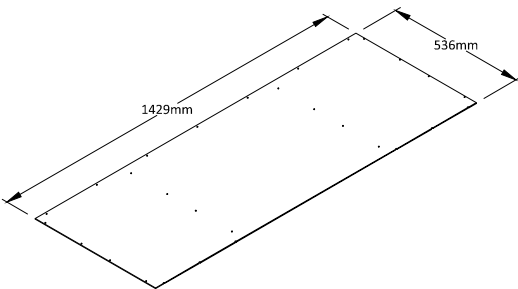

52
UPPER BACK PANEL
Qty:1

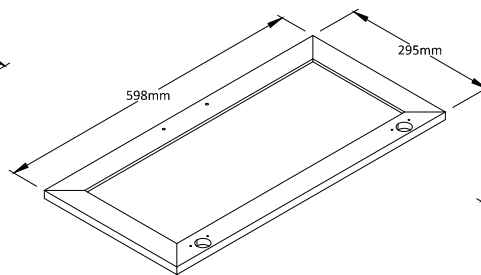

53
UPPER DOOR
Qty:2

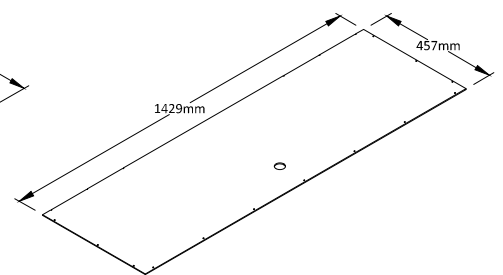

54
UPPER BACK PANEL
Qty:1

Parts

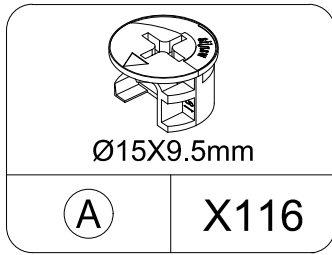

CAM LOCK
spare:3

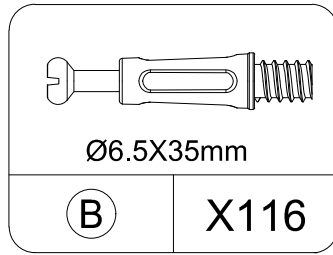

CAM BOLT
spare:3

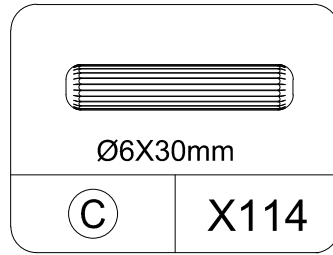

WOODEN DOWEL
spare:3

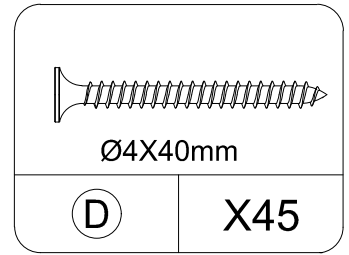

SCREW
spare:2

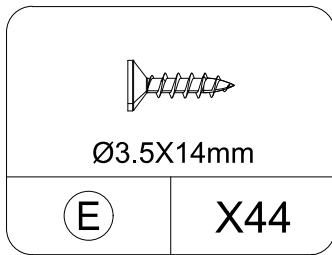

SCREW
spare:2

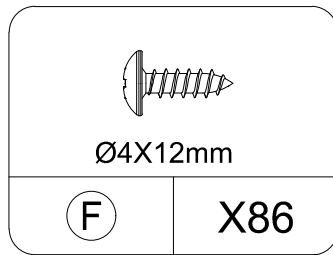

SCREW
spare:3

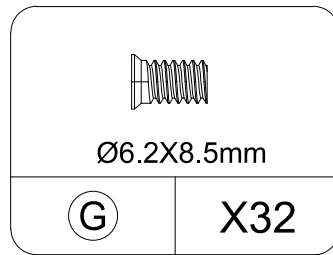

SCREW
spare:2

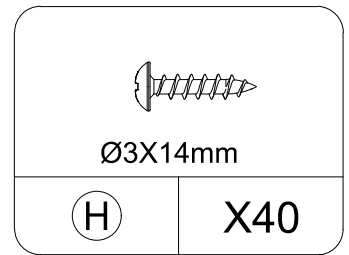

SCREW
spare:2

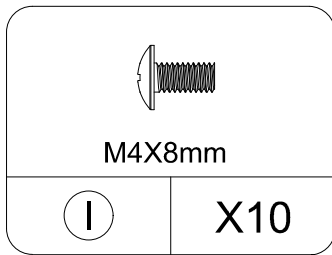

BOLT
spare:1

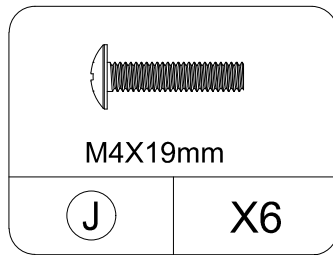

BOLT

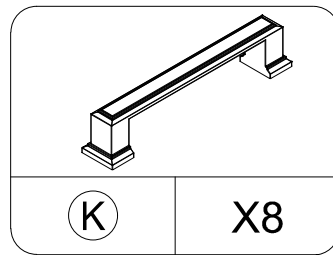

HANDLE

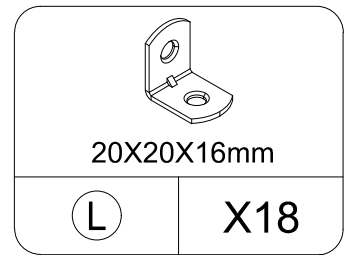

L-SHAPED IRON

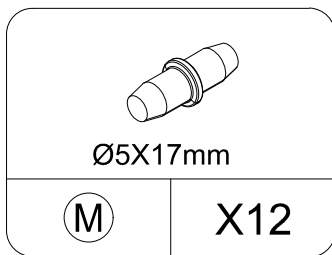

SHELF SUPPORT
spare:1

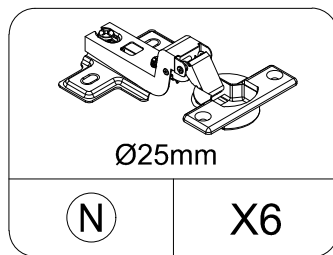

HINGE

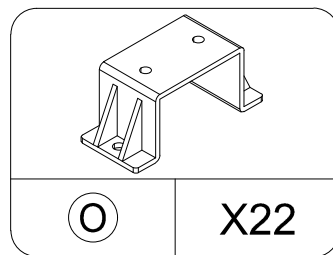

U-BRACKET

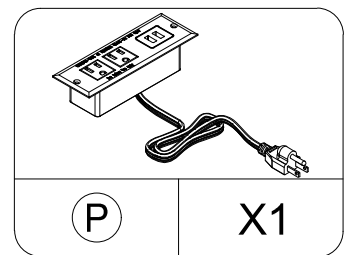

PLUG BOARD

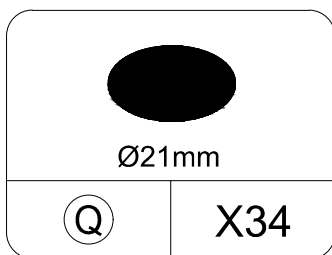

HOLE STICKERS
spare:2

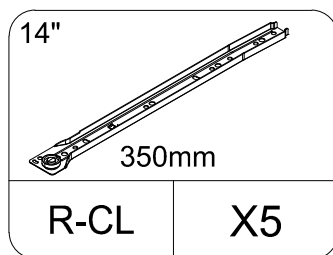

LEFT CABINET MEMBER

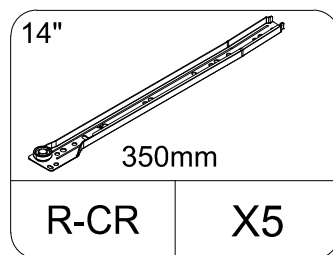

RIGHT CABINET MEMBER

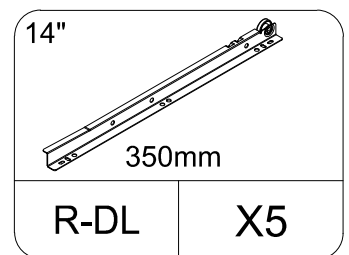

LEFT DRAWER RUNNER

Parts

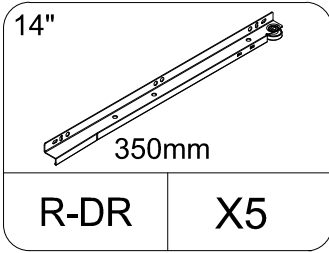

RIGHT DRAWER RUNNER

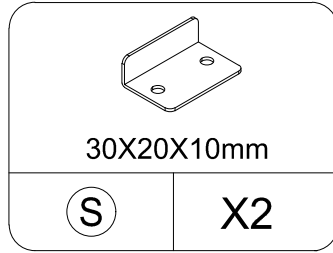

STOPPER

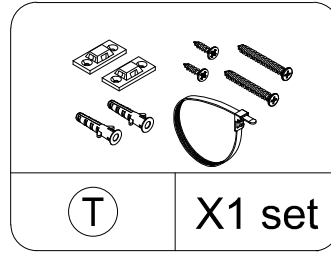

ANTI-TIPPING HARDWARE

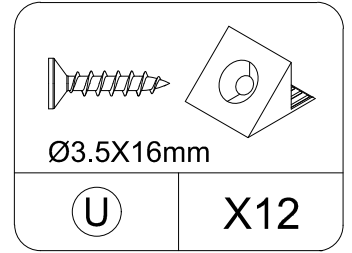

BACKBOARD BUCKLE

Cam Lock Fastening System

This Cam Lock Fastening System will be used throughout the assembly process

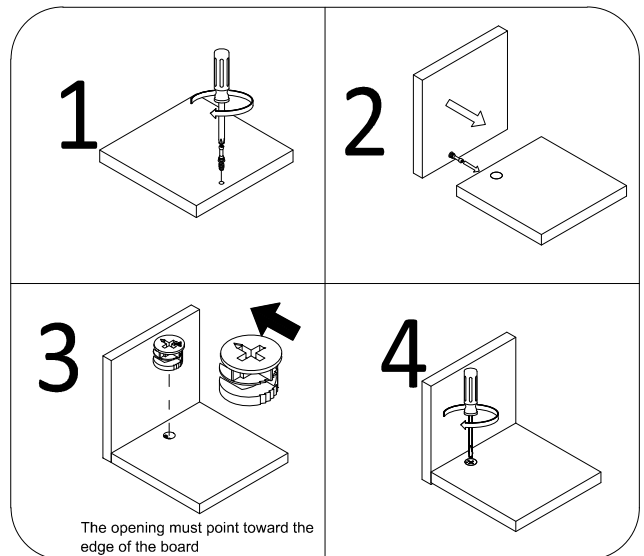
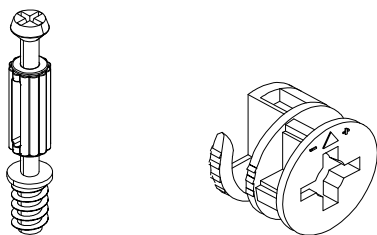

Assembly Instructions

STEP 1

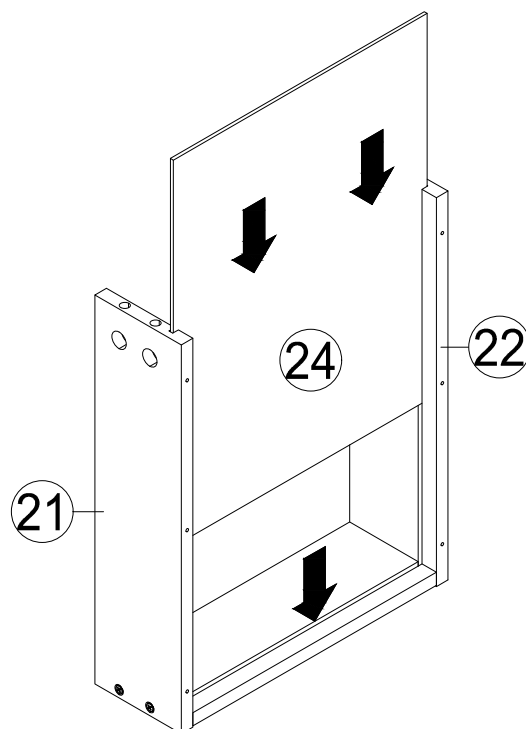
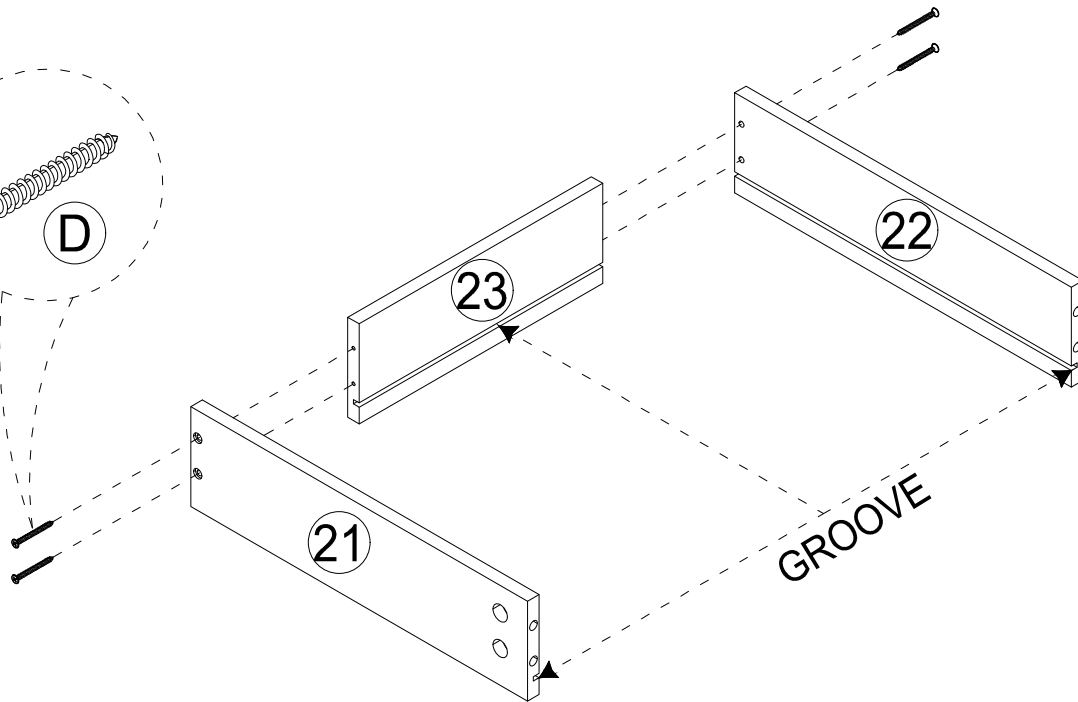
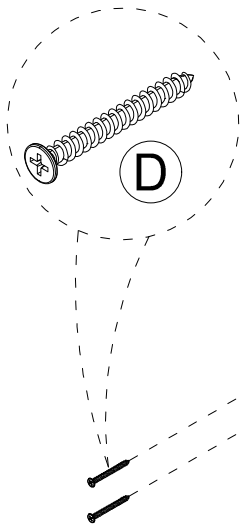
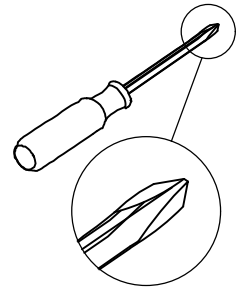
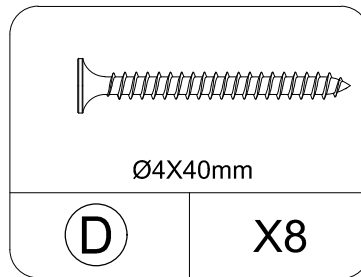

x 2

Assembly Instructions

STEP 2

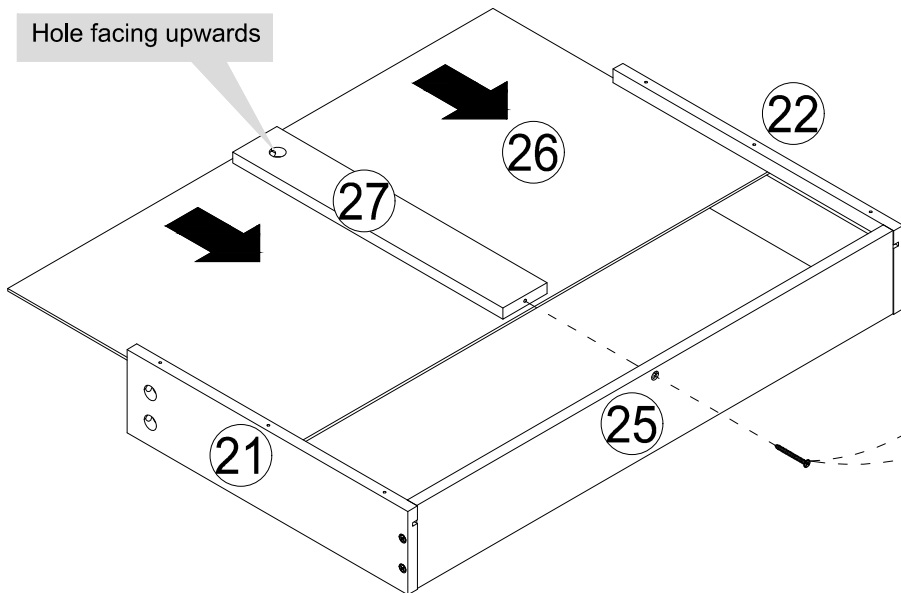
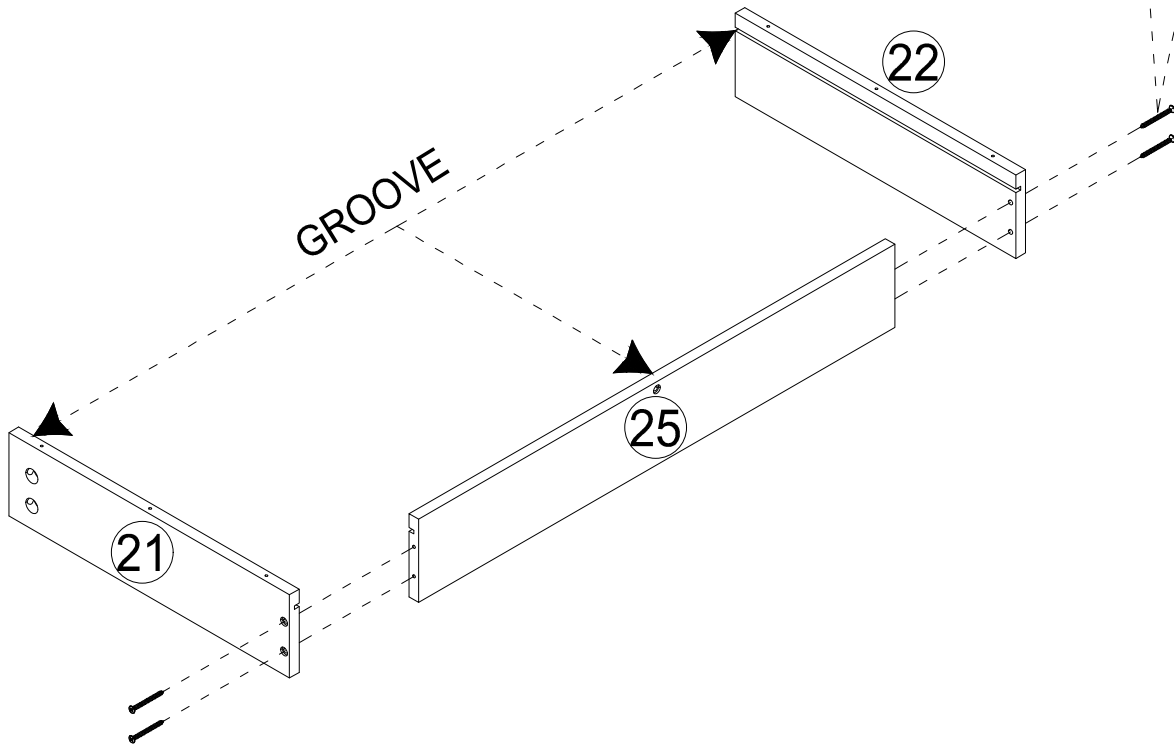
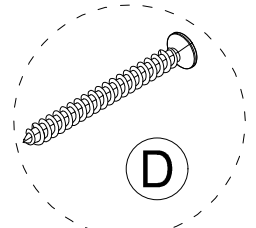
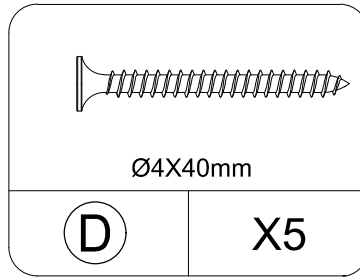
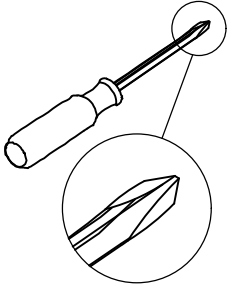

Assembly Instructions

STEP 3

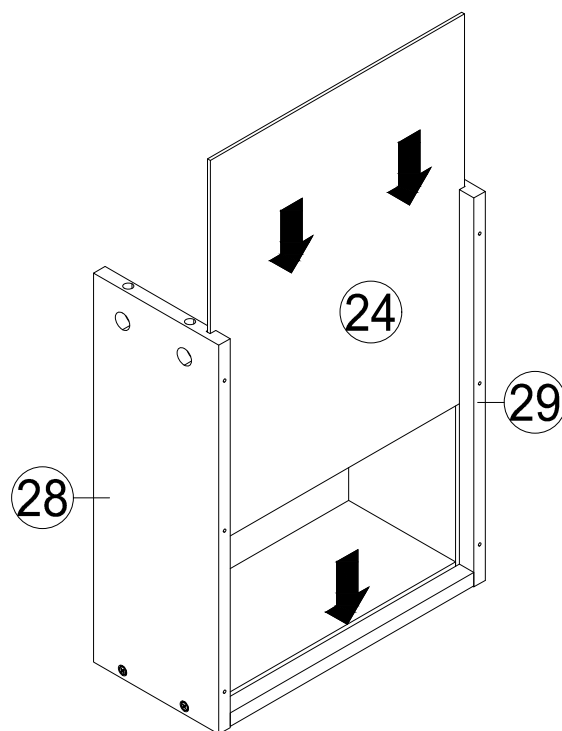
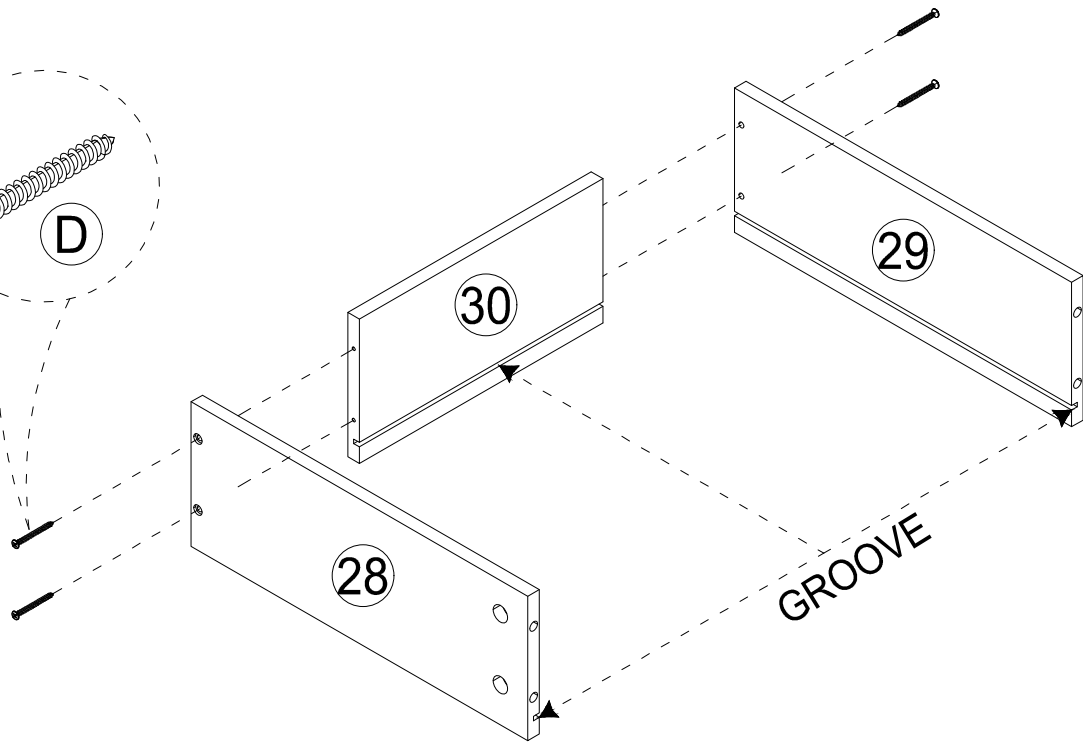
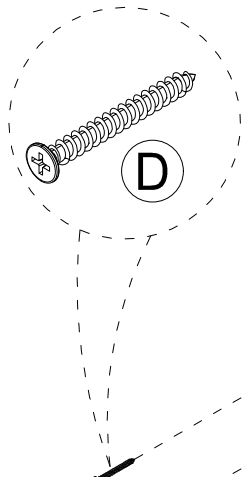
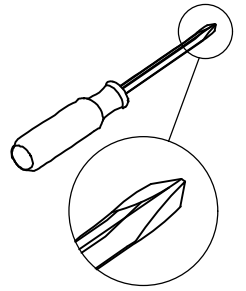
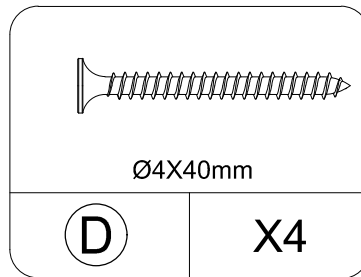

Assembly Instructions

STEP 4

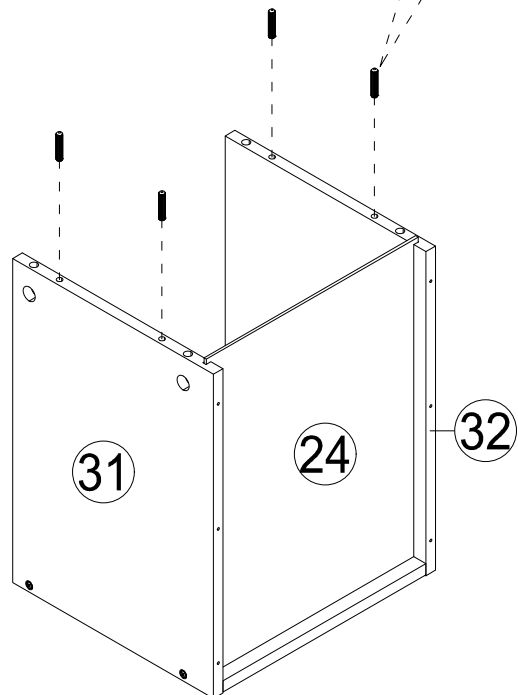
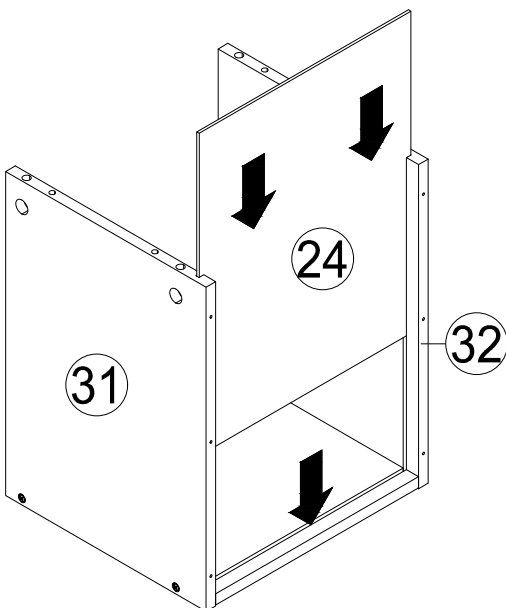
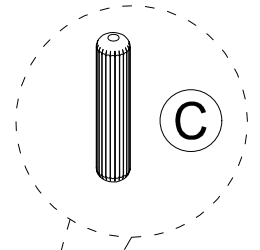
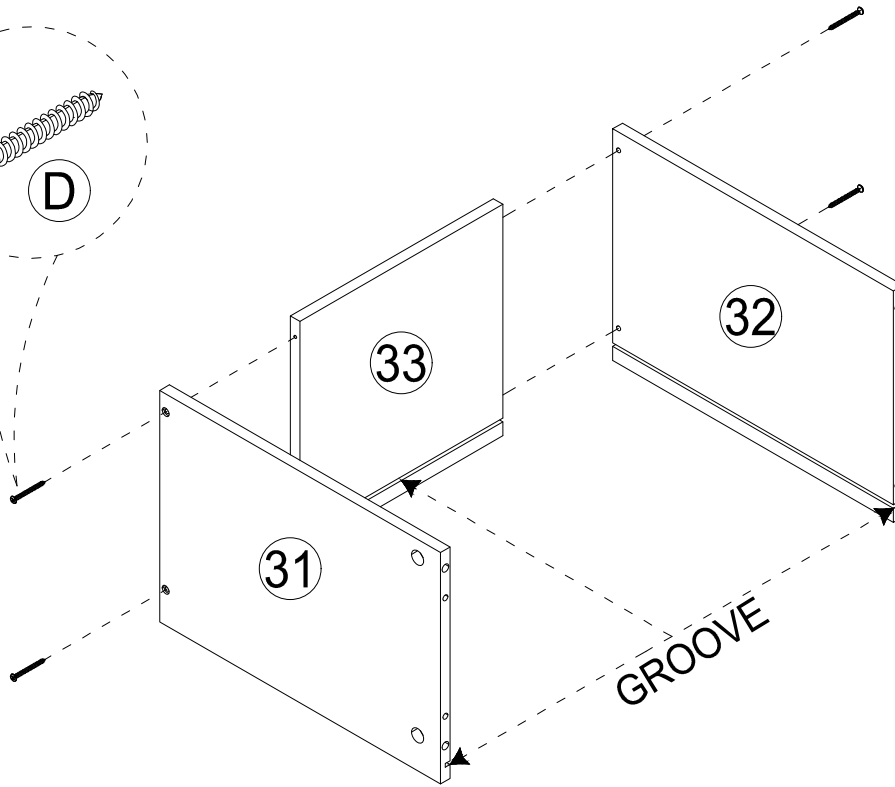
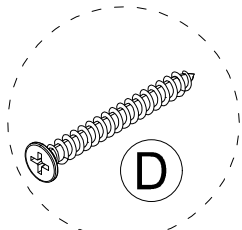
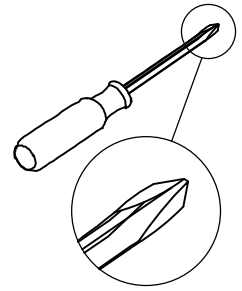
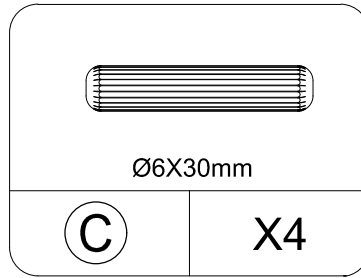
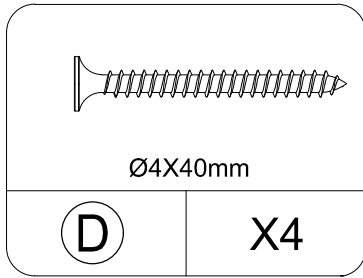

Assembly Instructions

STEP 5

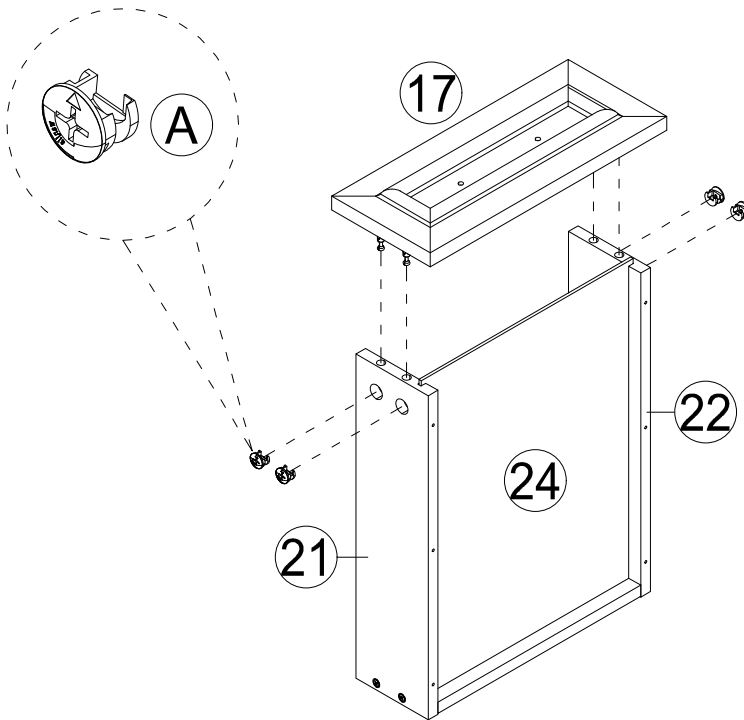
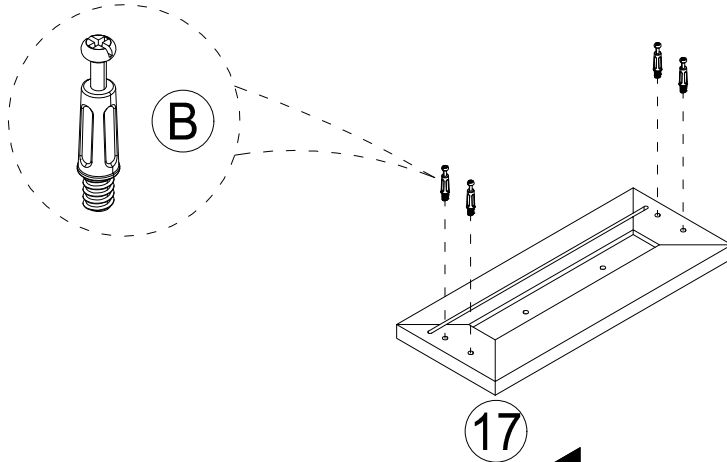
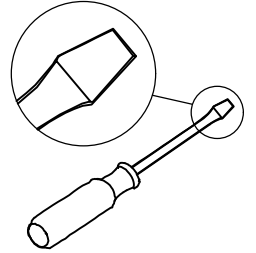
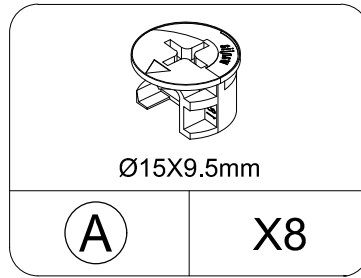
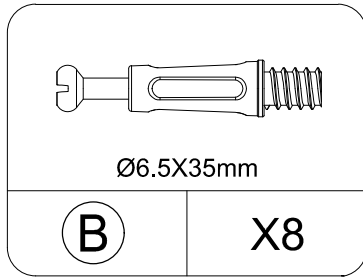
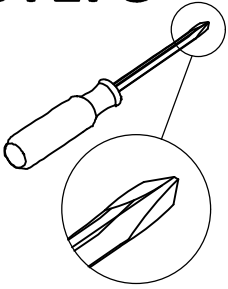

Insert the cam bolt into the hole first, then insert the cam lock and lock it.

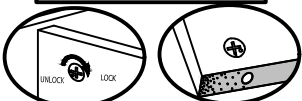

Proper orientation of CAM LOCK

x 2

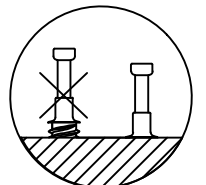

Assembly Instructions

STEP 6

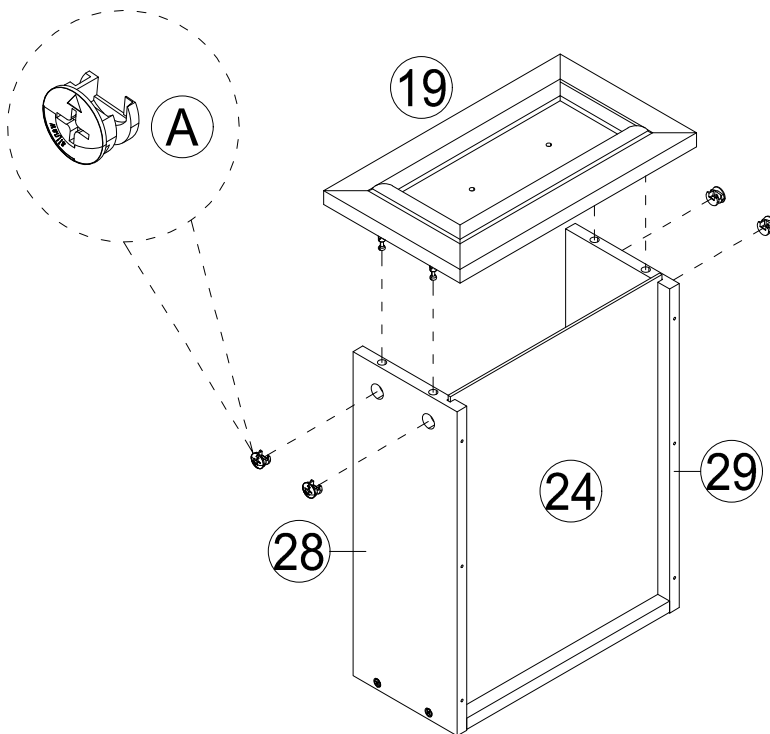
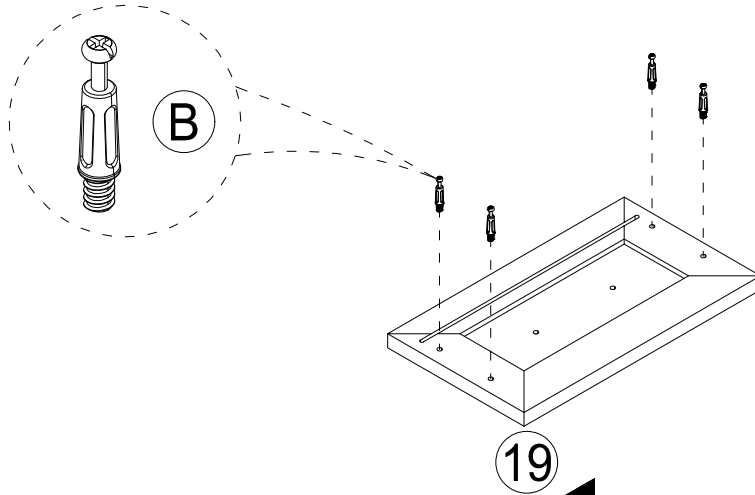
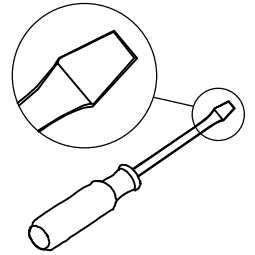
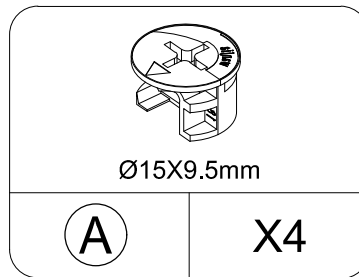
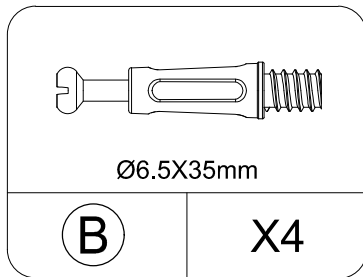
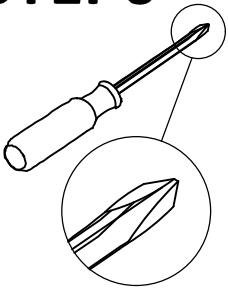

Insert the cam bolt into the hole first, then insert the cam lock and lock it.

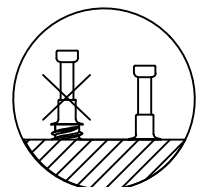

Assembly Instructions

STEP 7

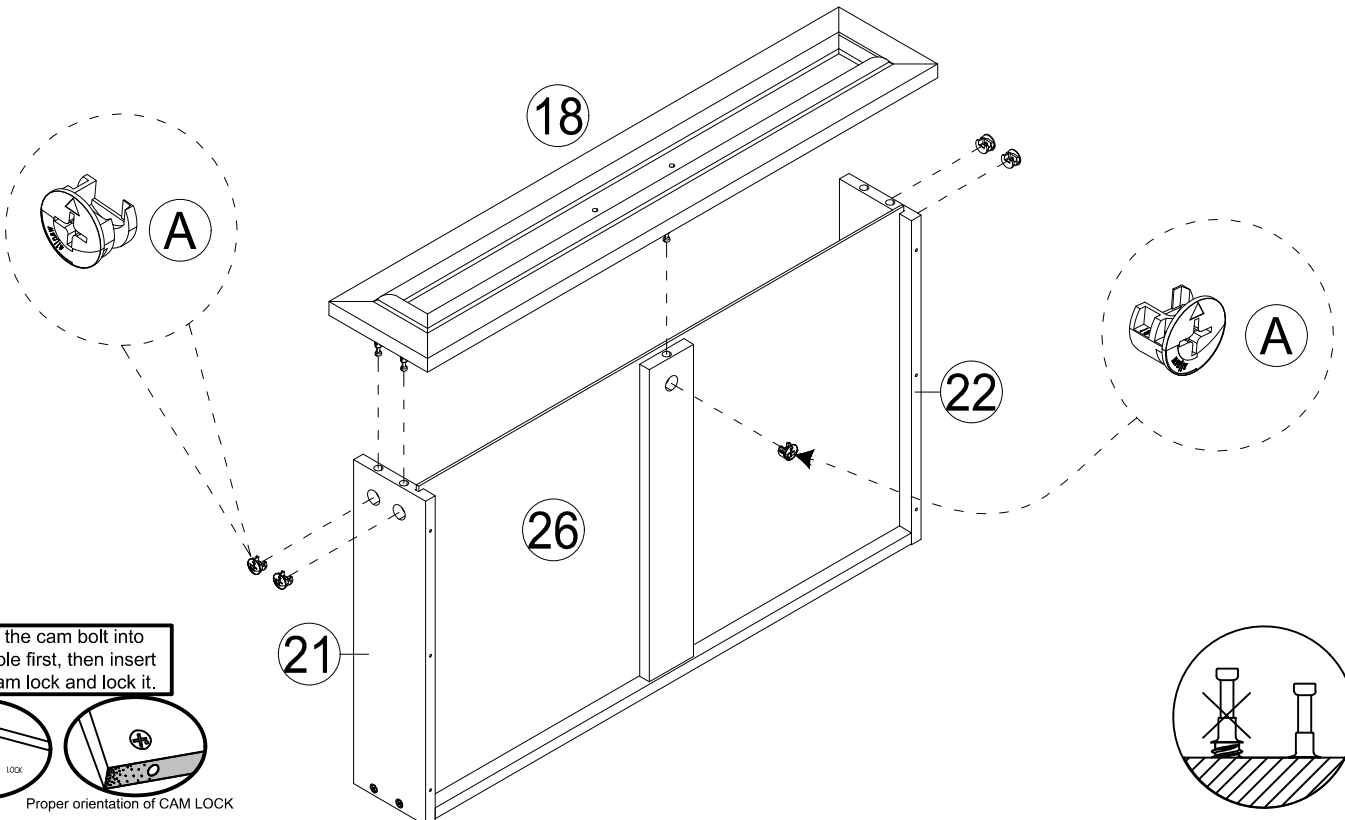
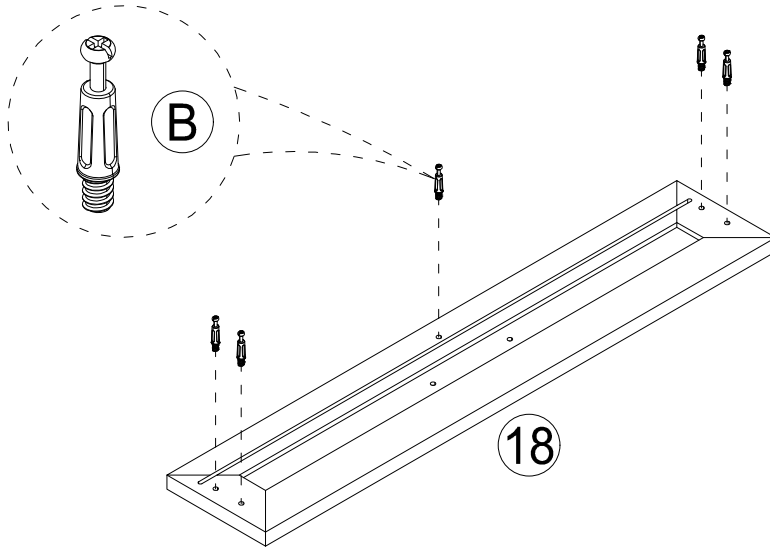
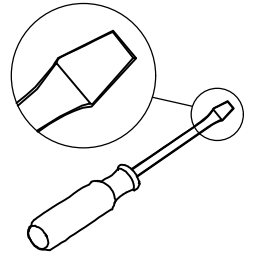
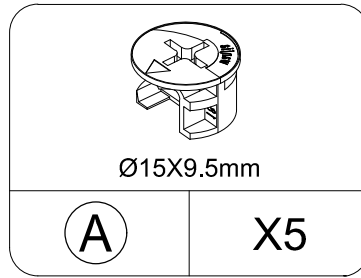
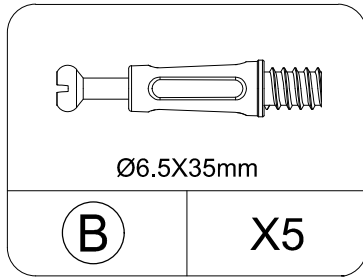
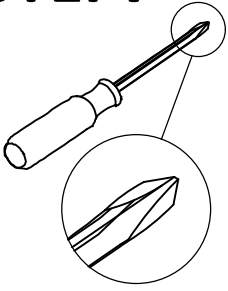

Insert the cam bolt into the hole first, then insert the cam lock and lock it.

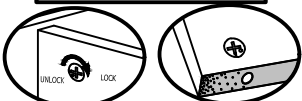

Assembly Instructions

STEP 8

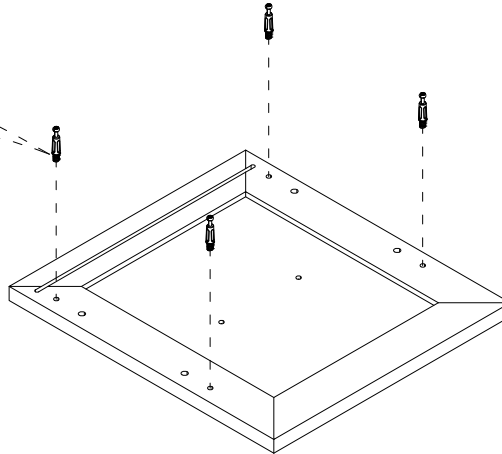
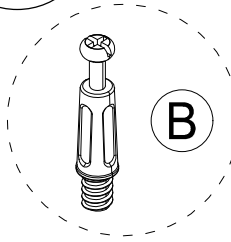
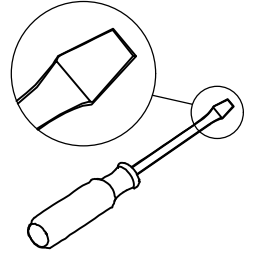
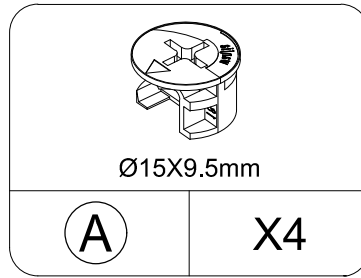
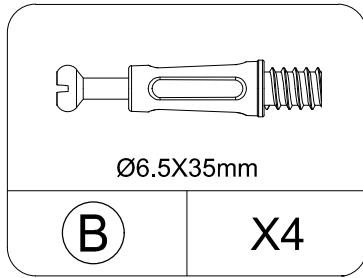
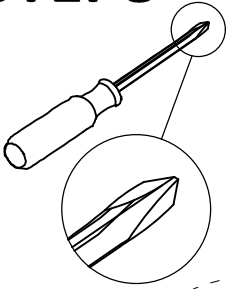

20

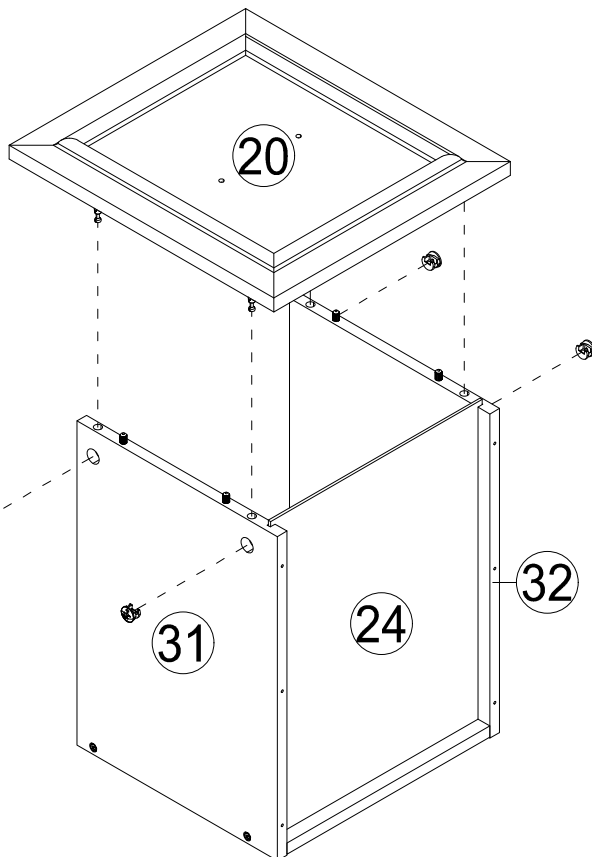
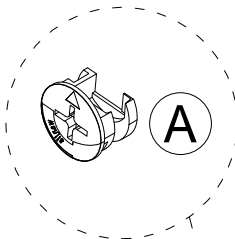

20

31

24

32

Insert the cam bolt into the hole first, then insert the cam lock and lock it.

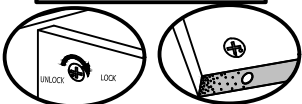

Proper orientation of CAM LOCK

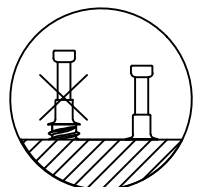

Assembly Instructions

STEP 9

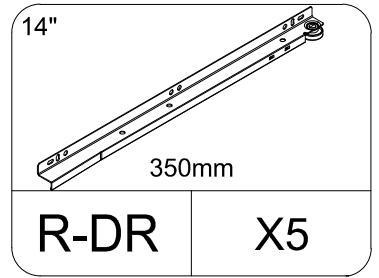
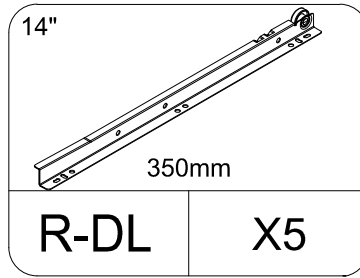
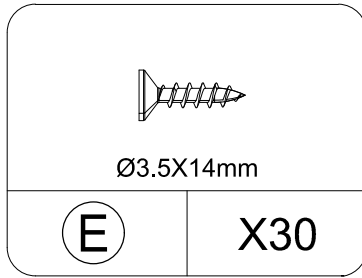
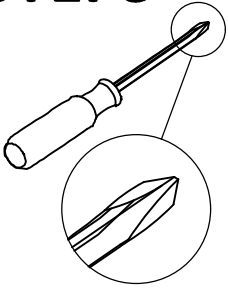

The installation steps for the drawer guide rail are the same

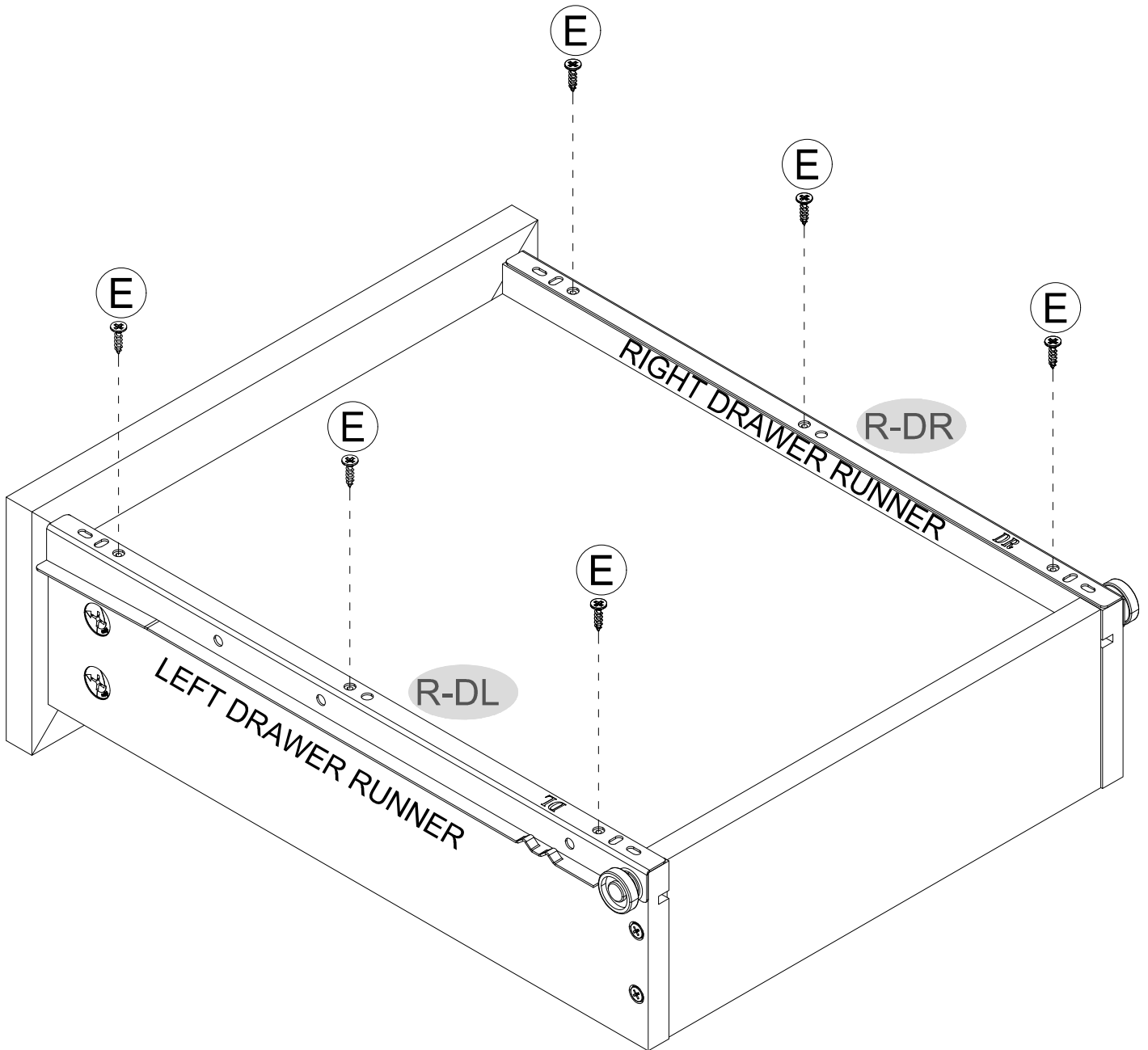

17 & 18 & 19 & 20

Assembly Instructions

STEP 10

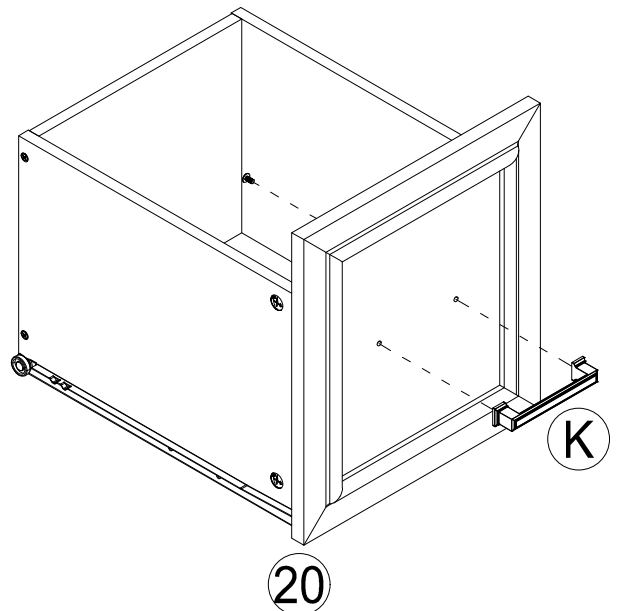
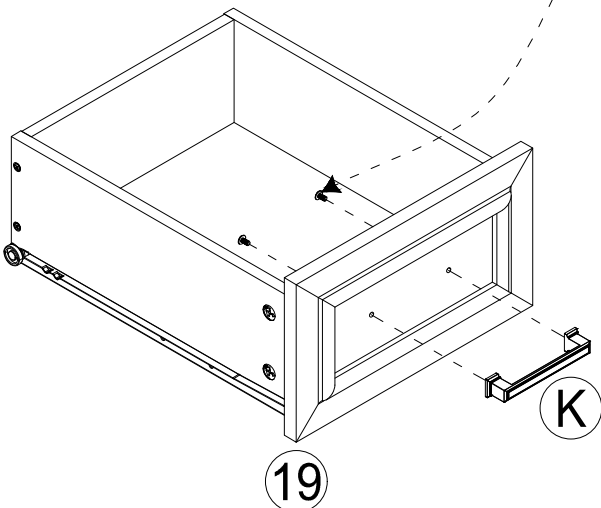
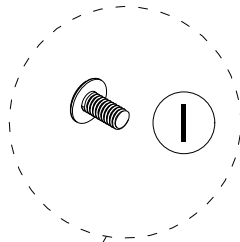
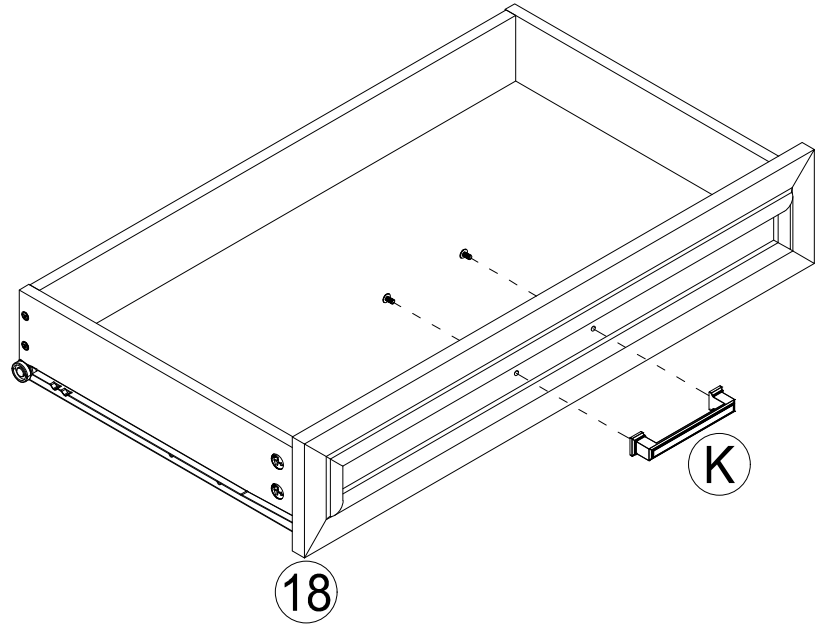
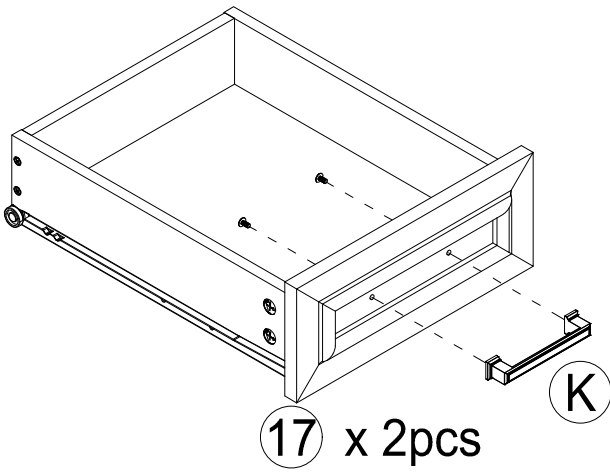
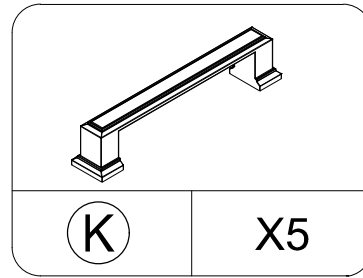
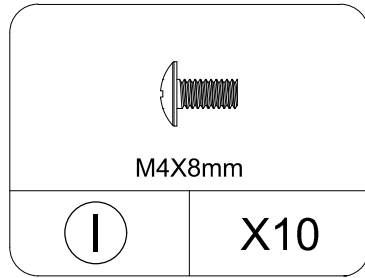
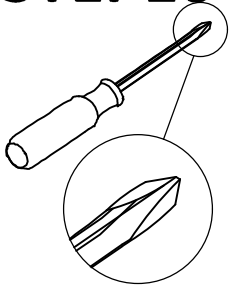

Assembly Instructions

STEP 11

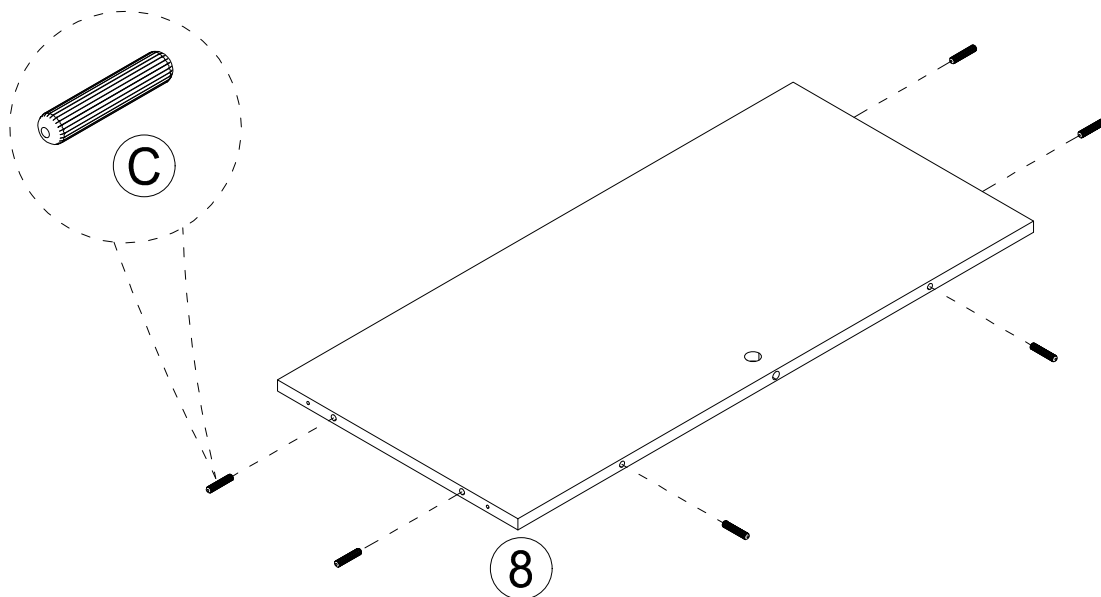
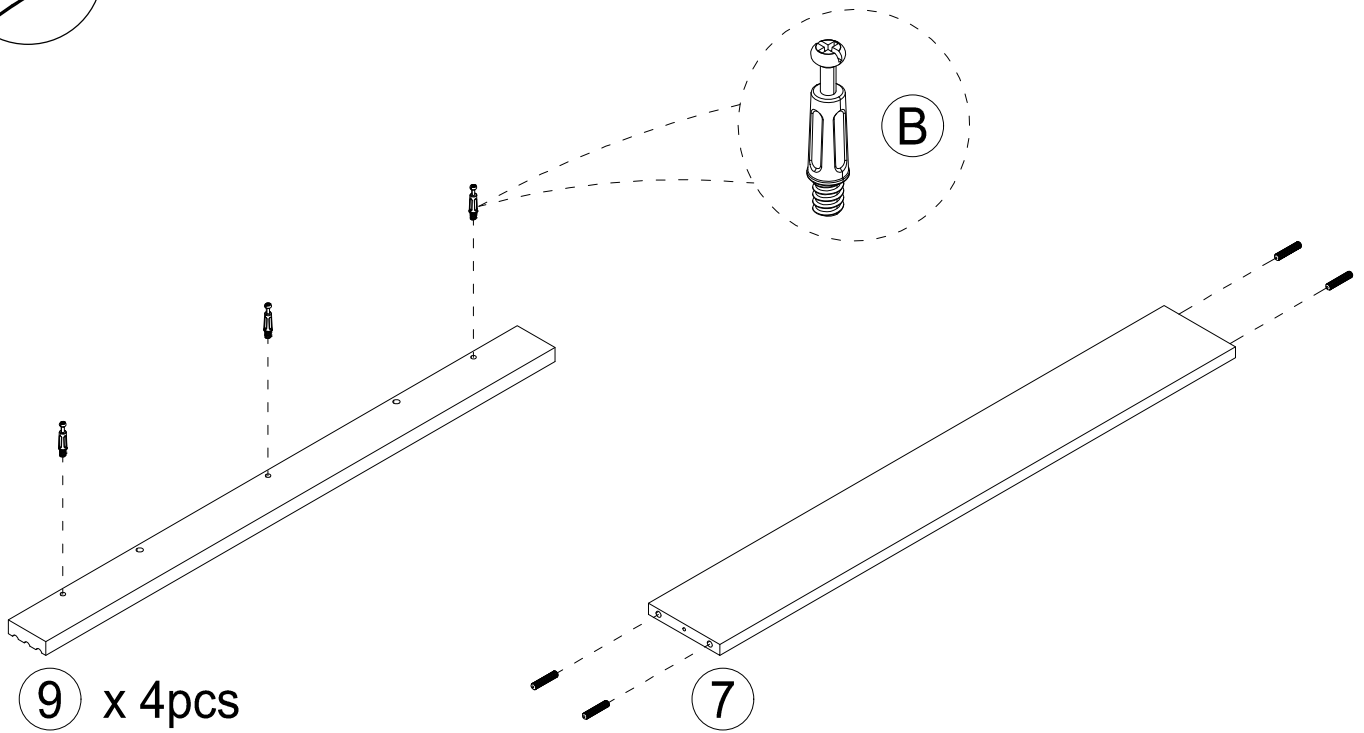
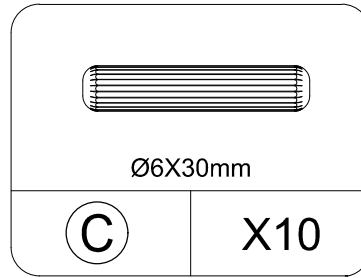
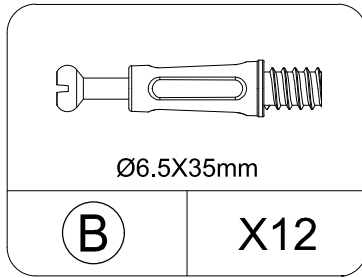
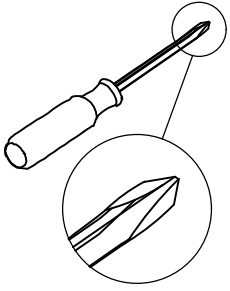

Assembly Instructions

STEP 12

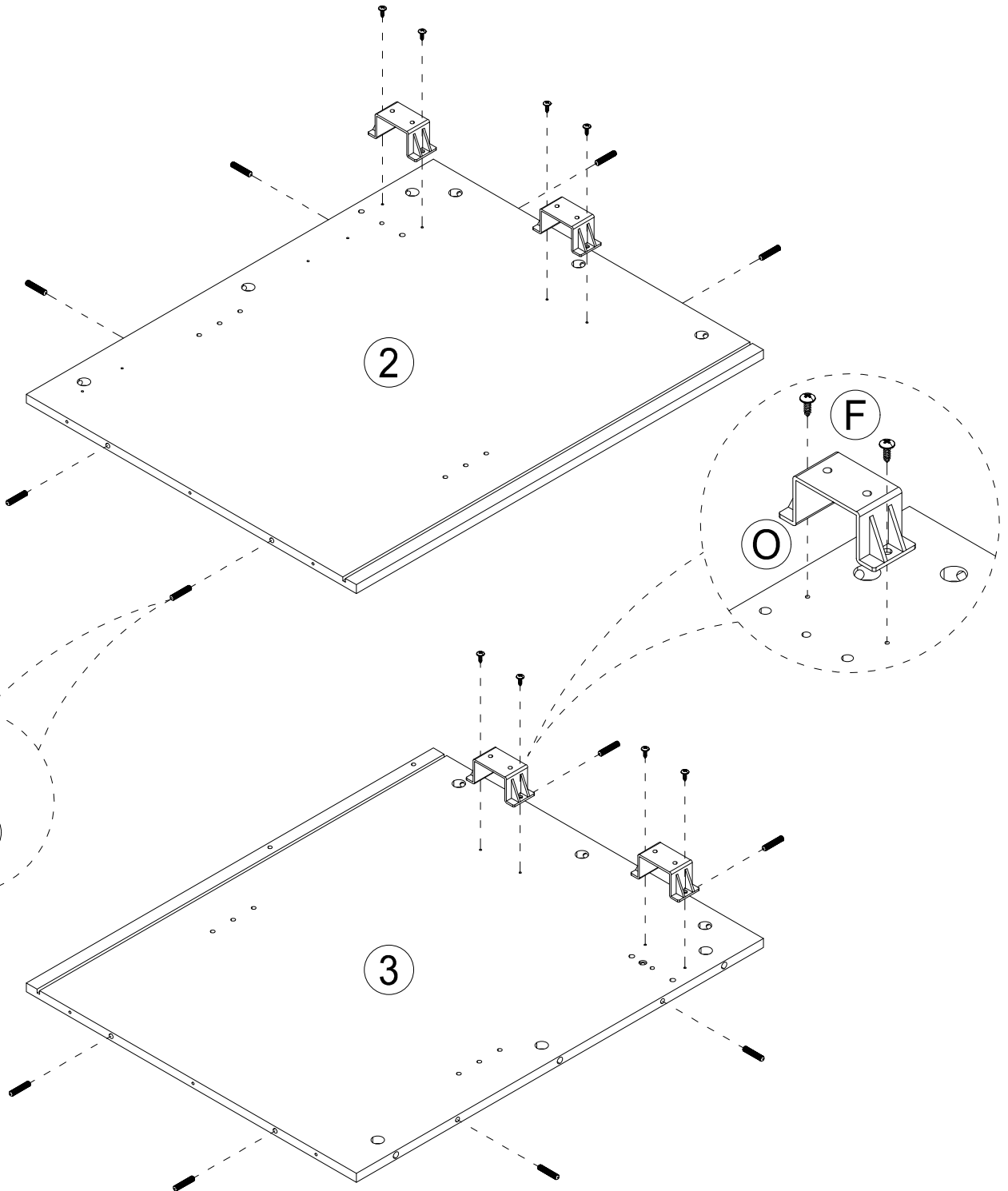
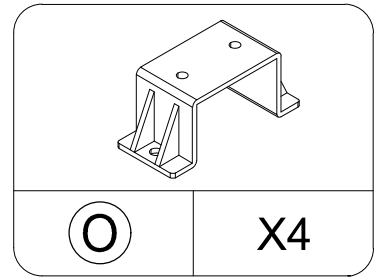
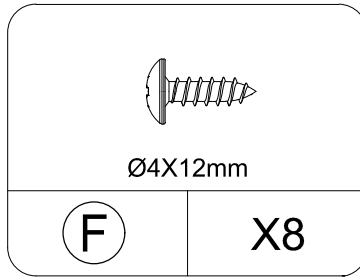
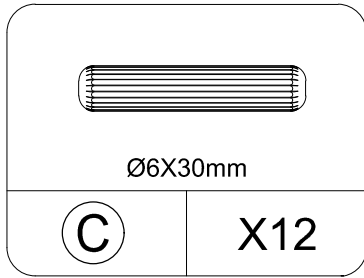
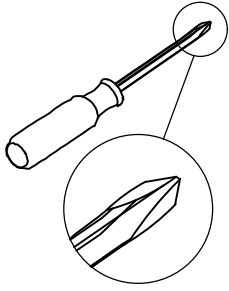

Assembly Instructions

STEP 13

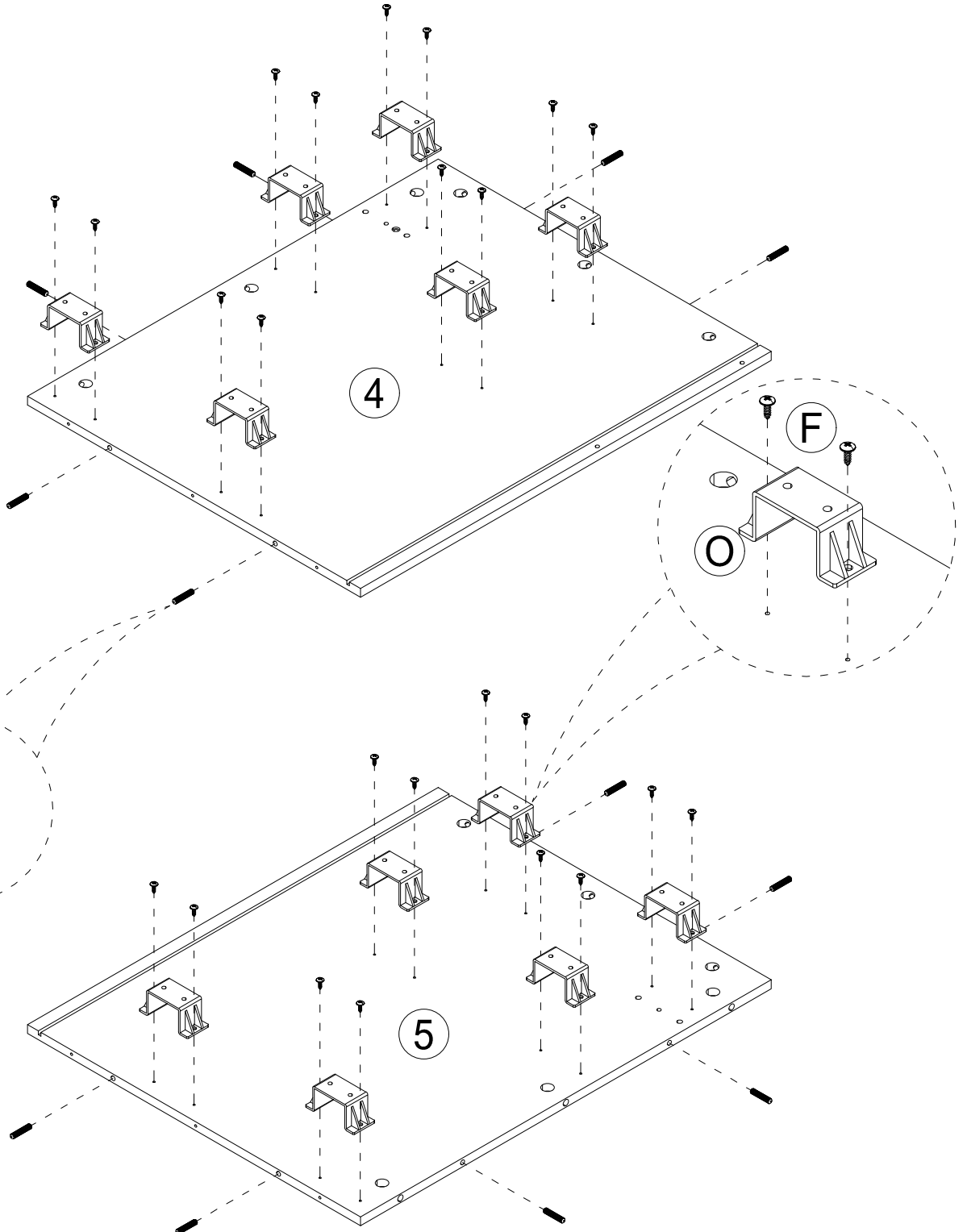
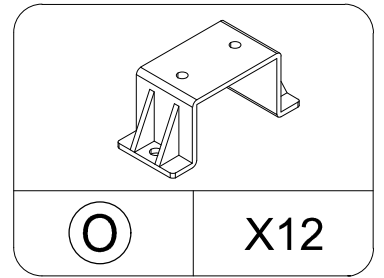
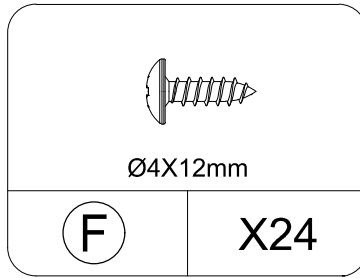
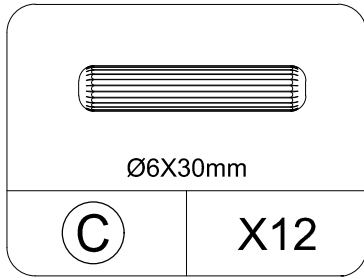
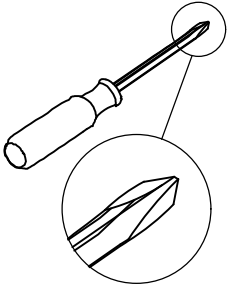

Assembly Instructions

STEP 14

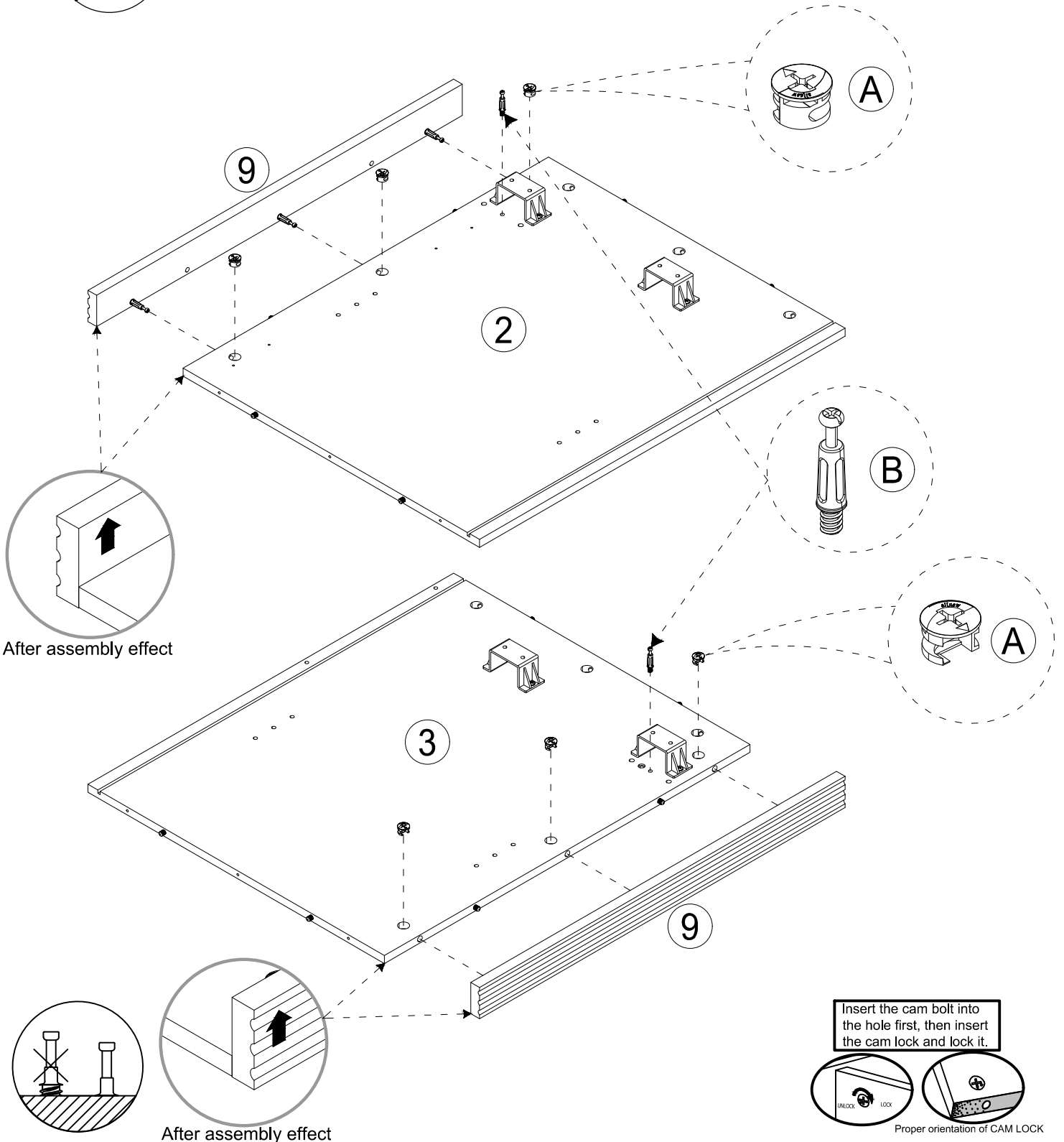
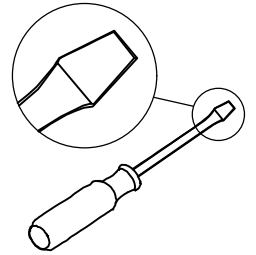
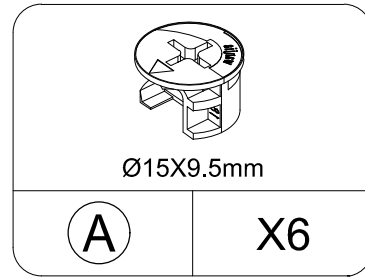
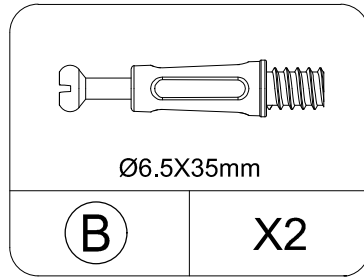
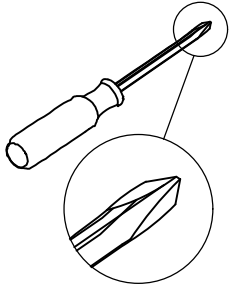

Assembly Instructions

STEP 15

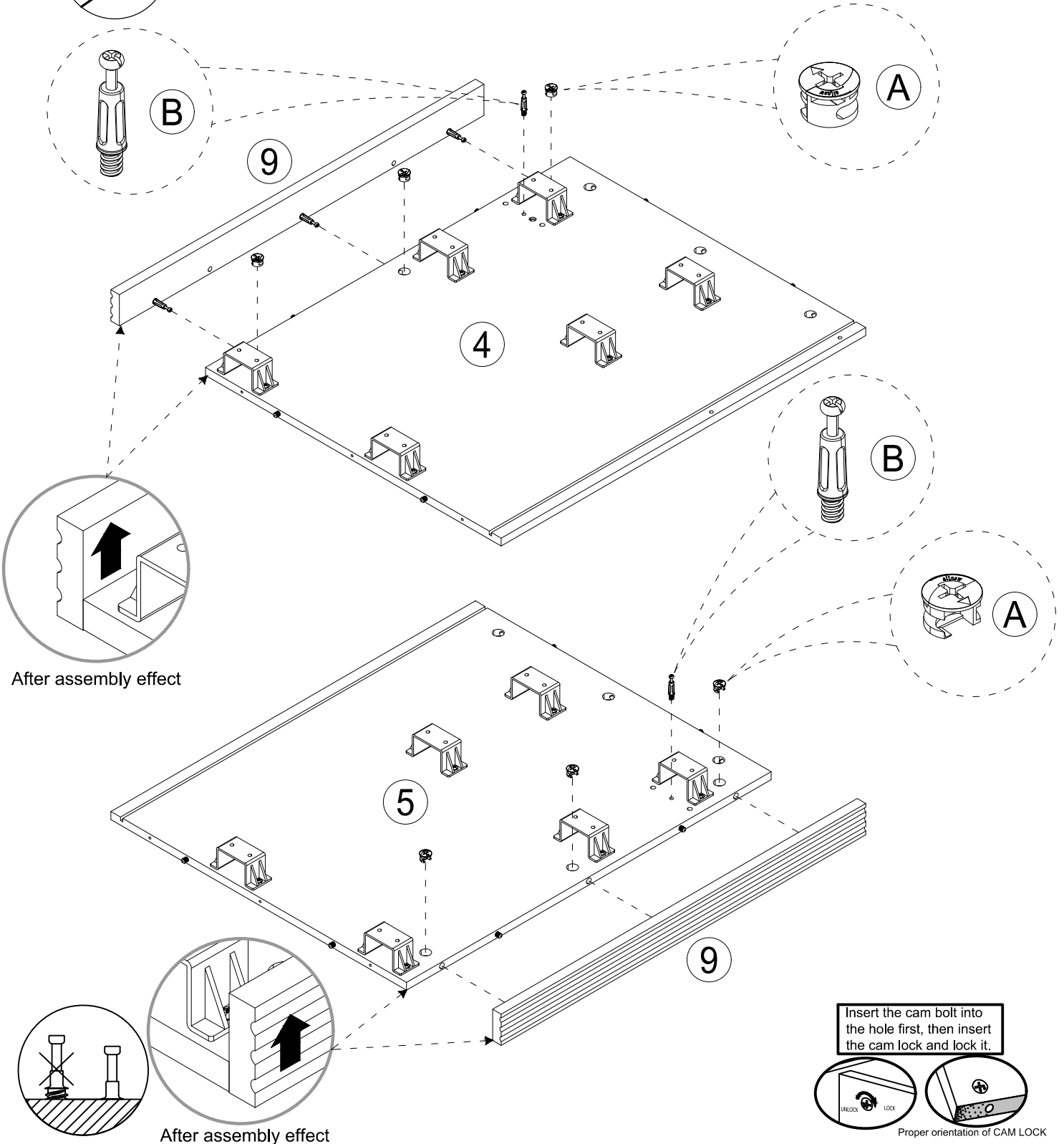
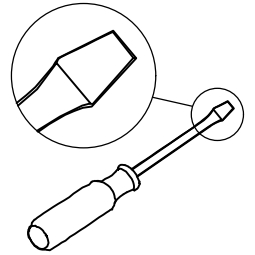
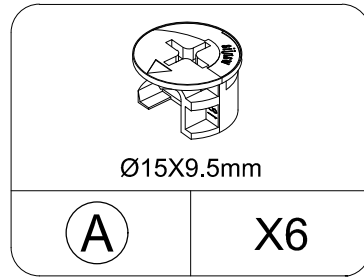
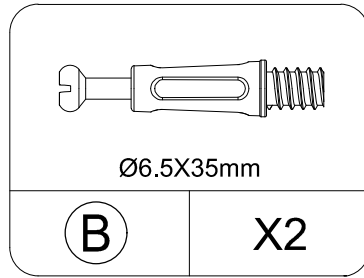
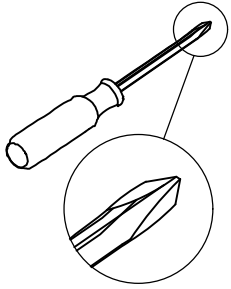

After assembly effect

After assembly effect

Insert the cam bolt into the hole first, then insert the cam lock and lock it.

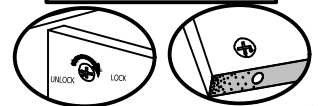

Proper orientation of CAM LOCK

Assembly Instructions

STEP 16

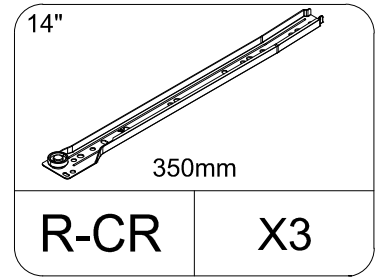
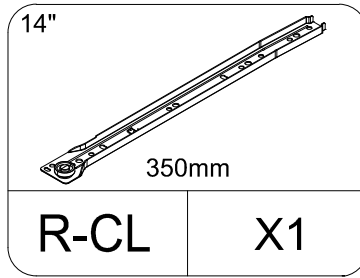
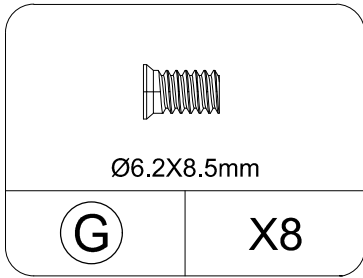
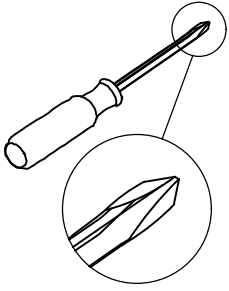

Lock the corresponding holes according to the diagram

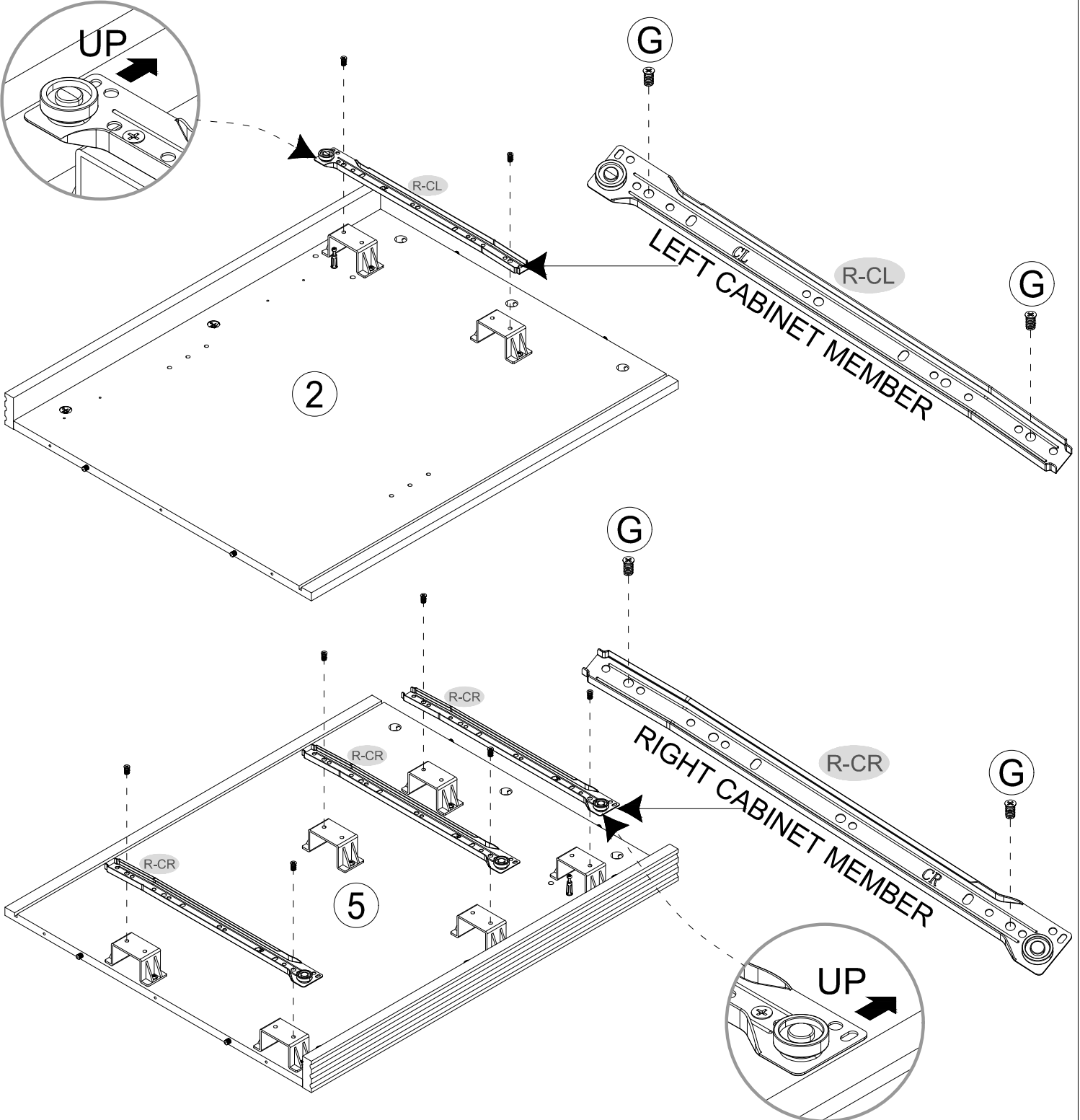

Assembly Instructions

STEP 17

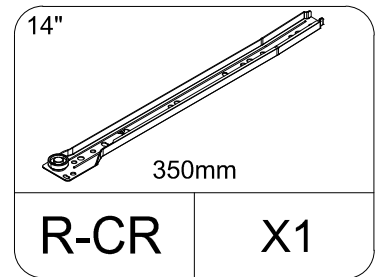
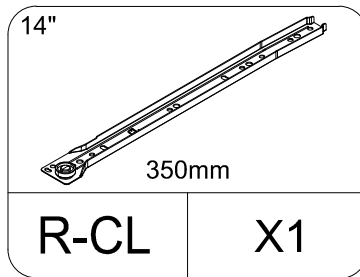
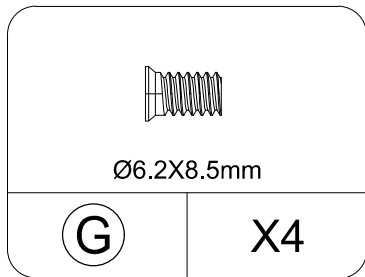
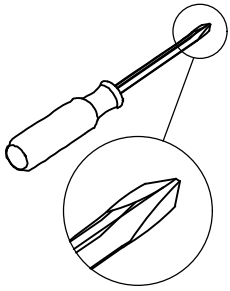

Lock the corresponding holes according to the diagram

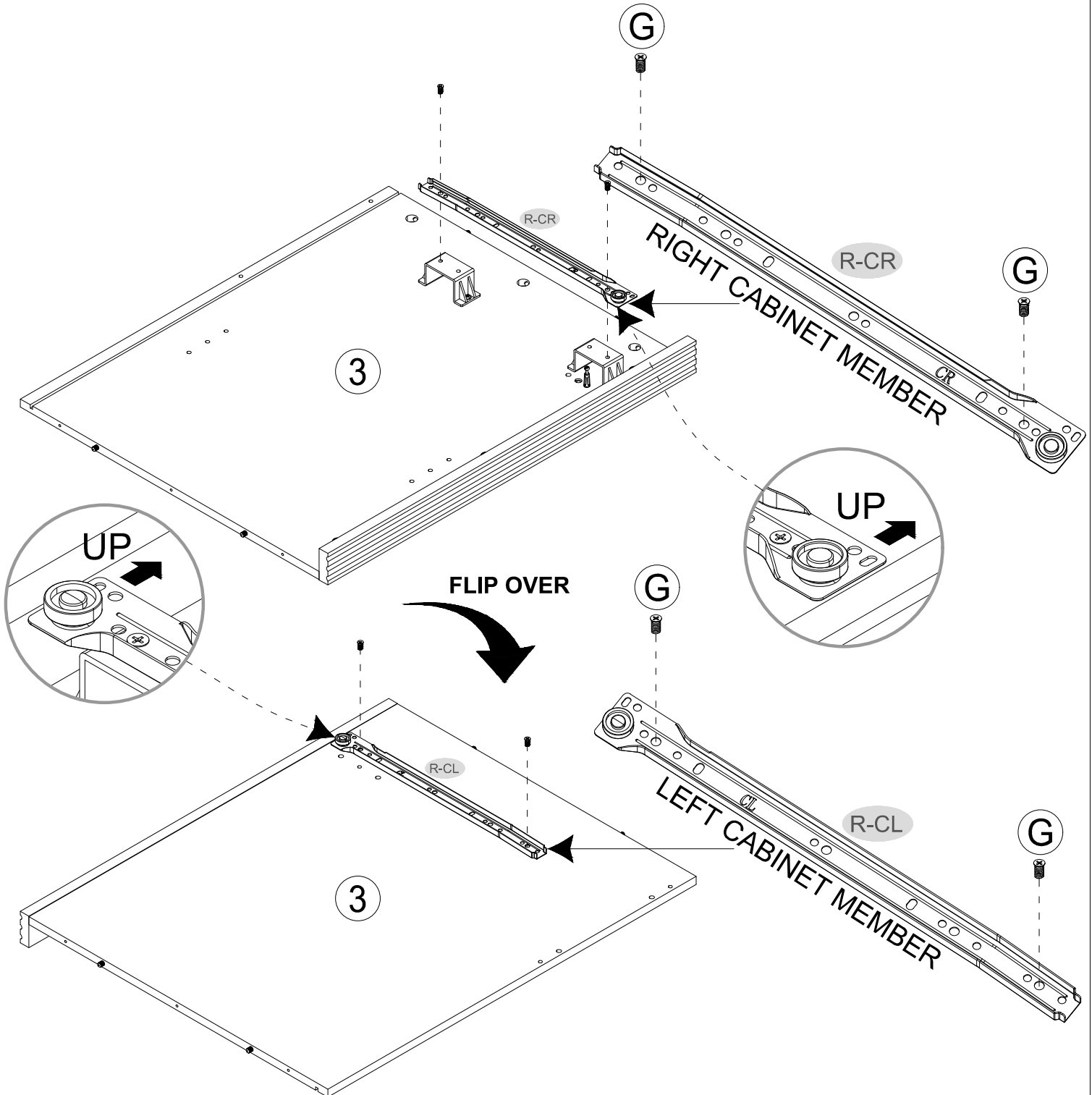

Assembly Instructions

STEP 18

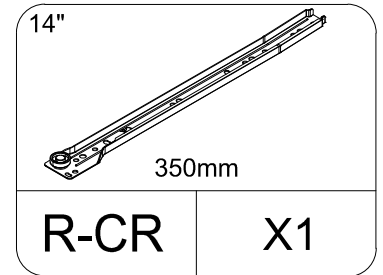
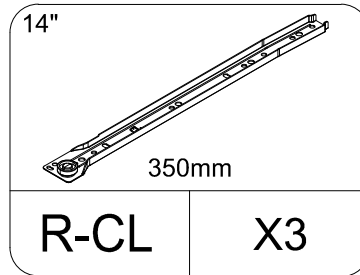
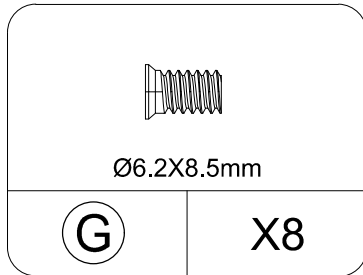
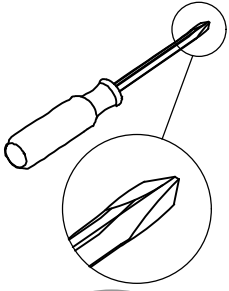

Lock the corresponding holes according to the diagram

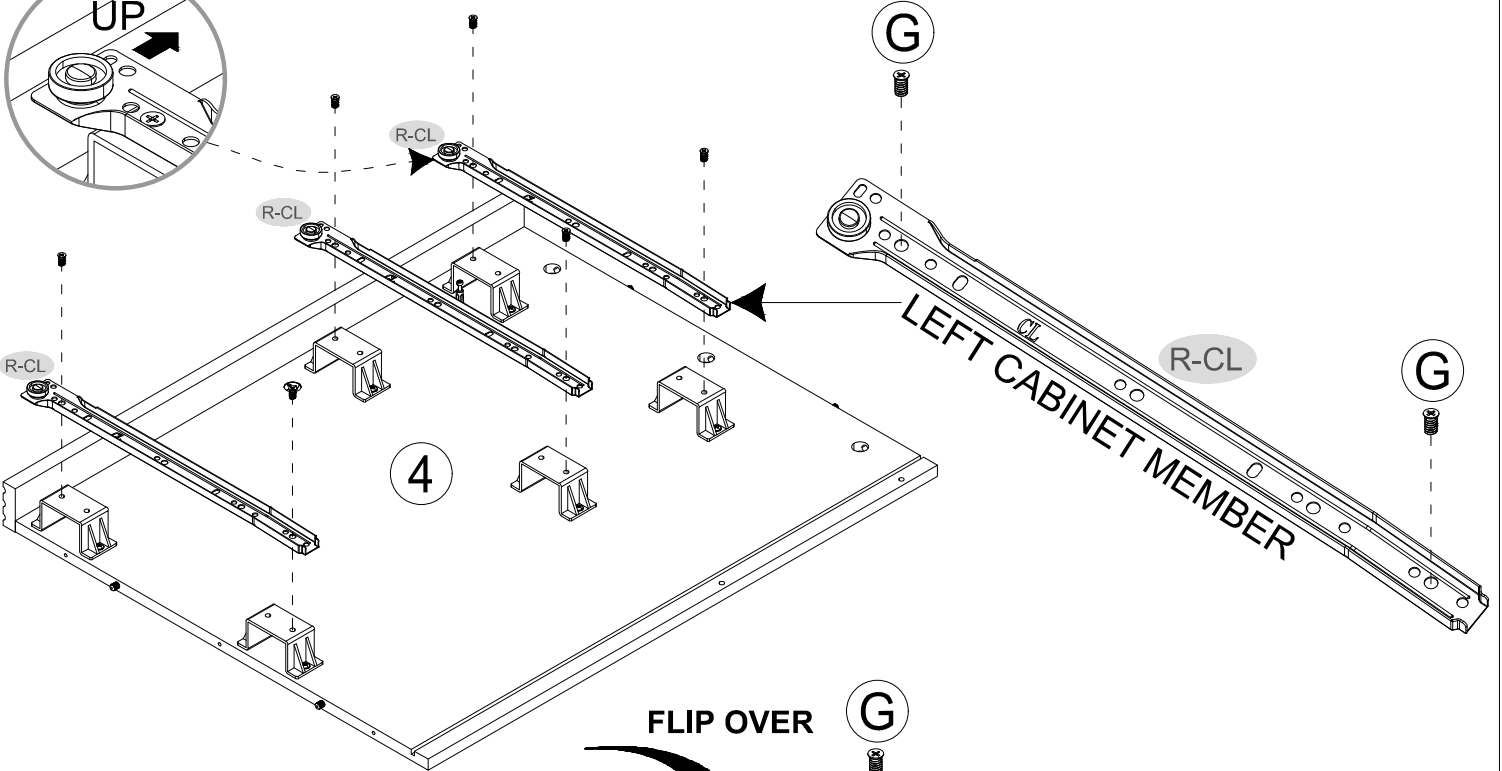
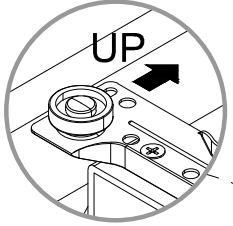

FLIP OVER

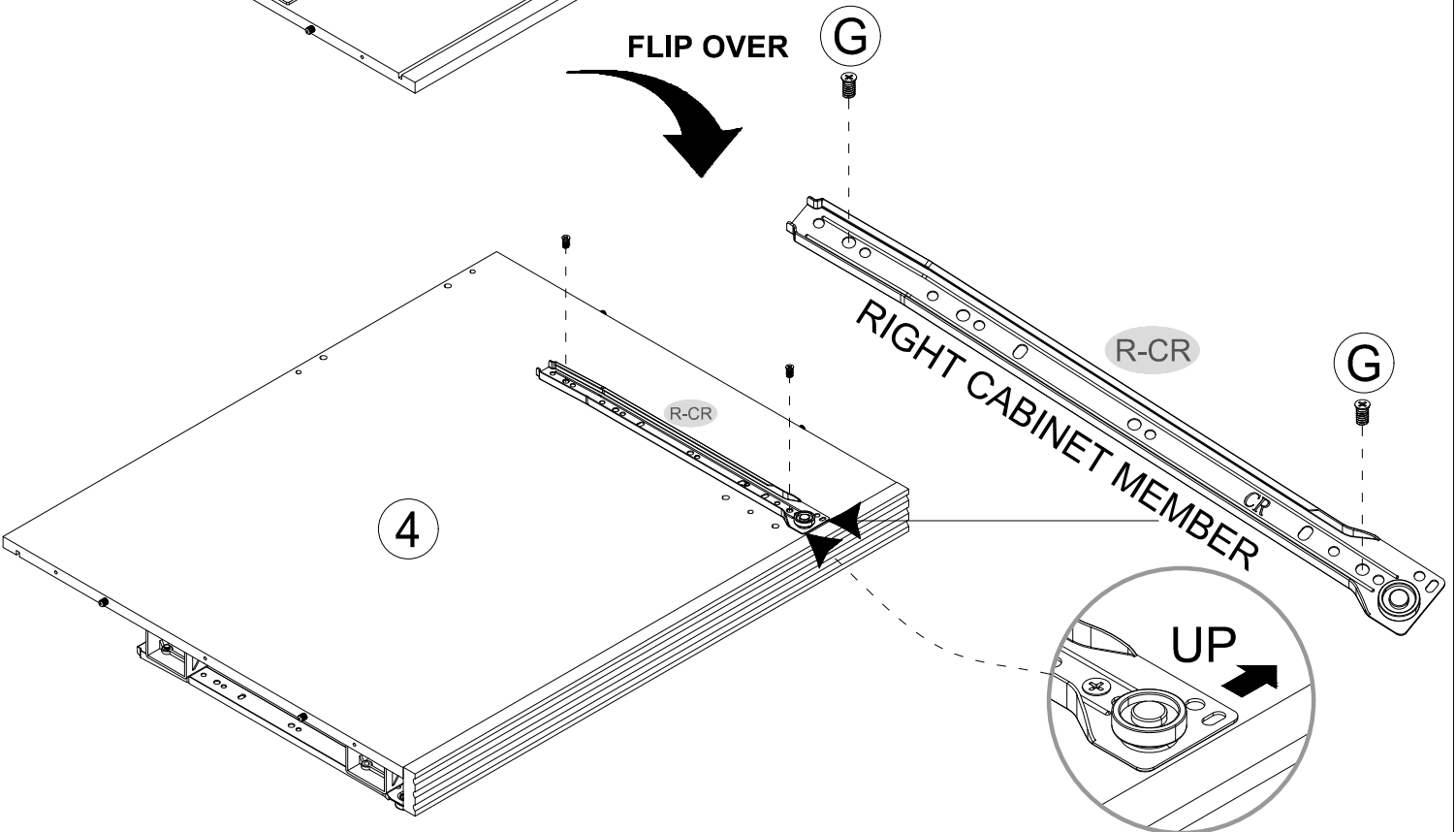

Assembly Instructions

STEP 19

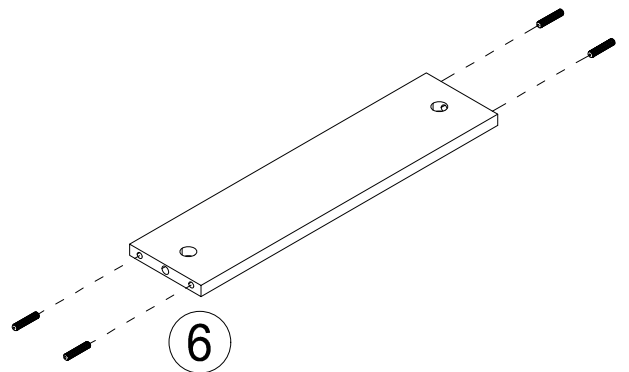
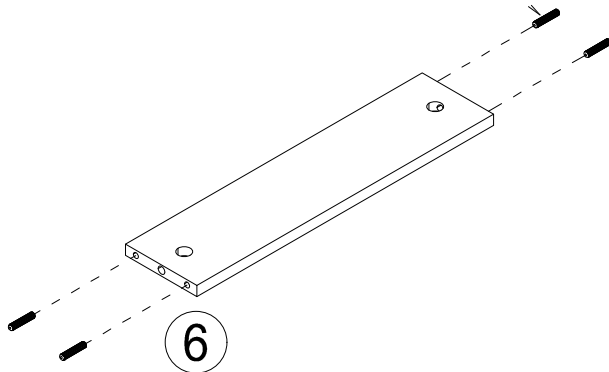
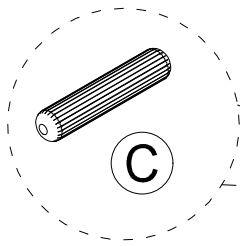
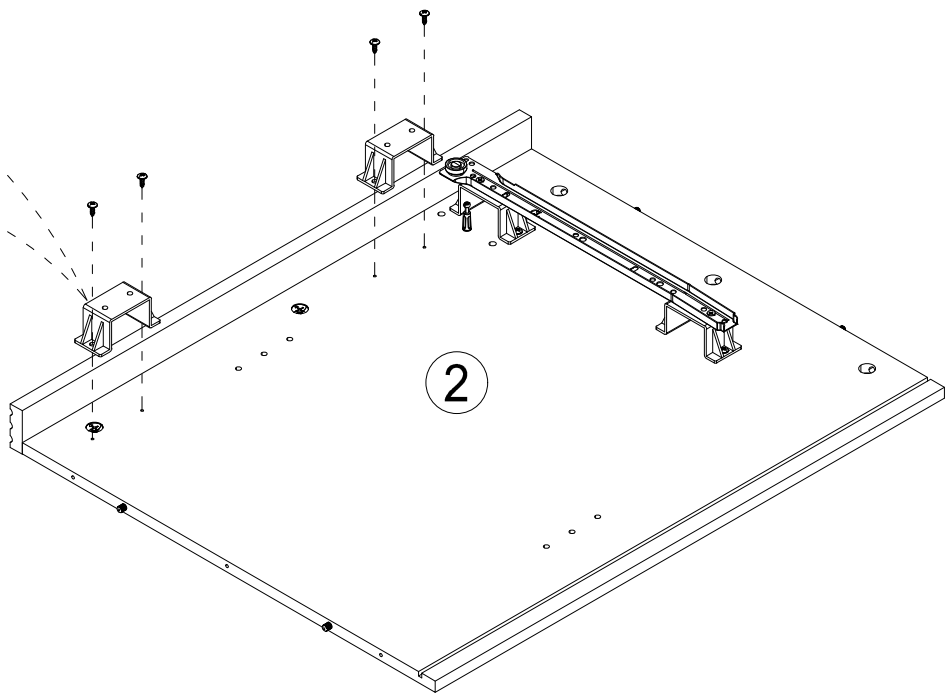
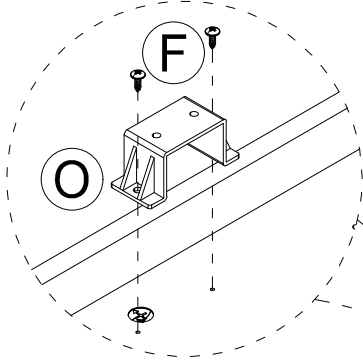
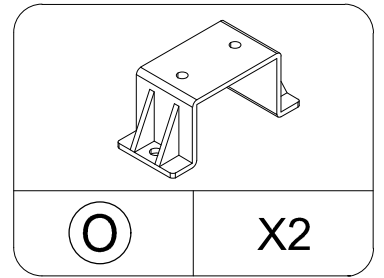
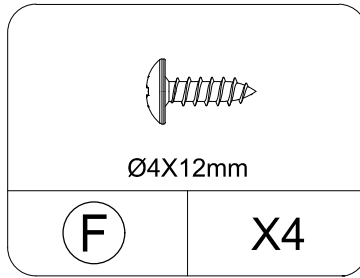
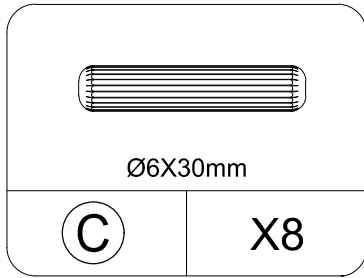
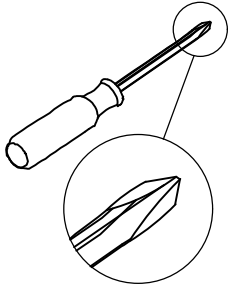

Assembly Instructions

STEP 20

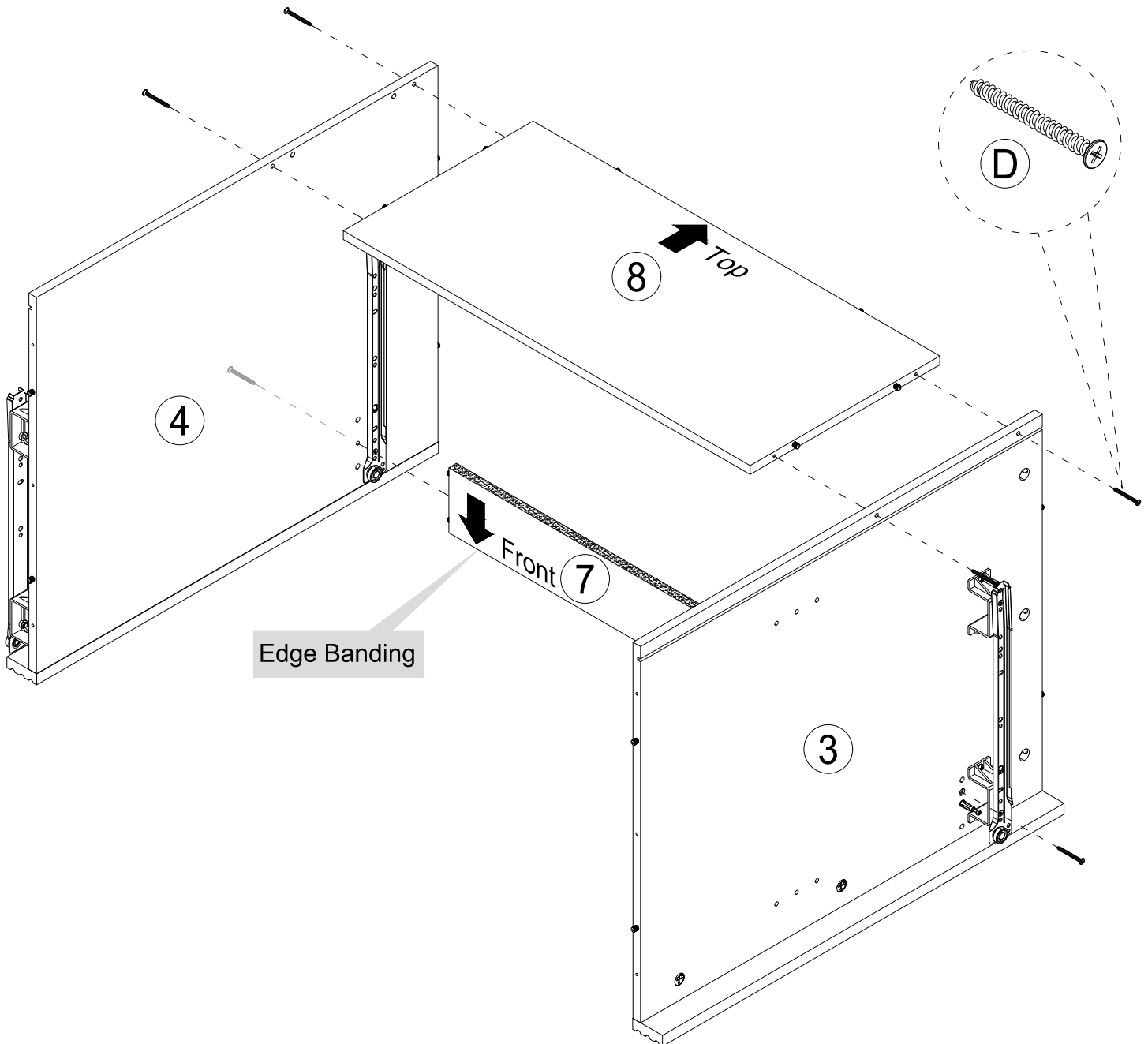
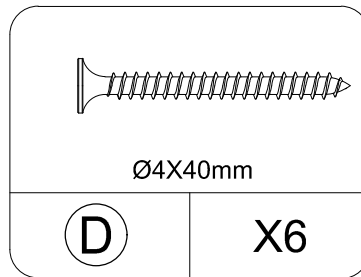
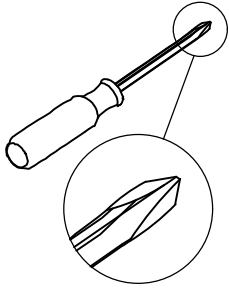

Assembly Instructions

STEP 21

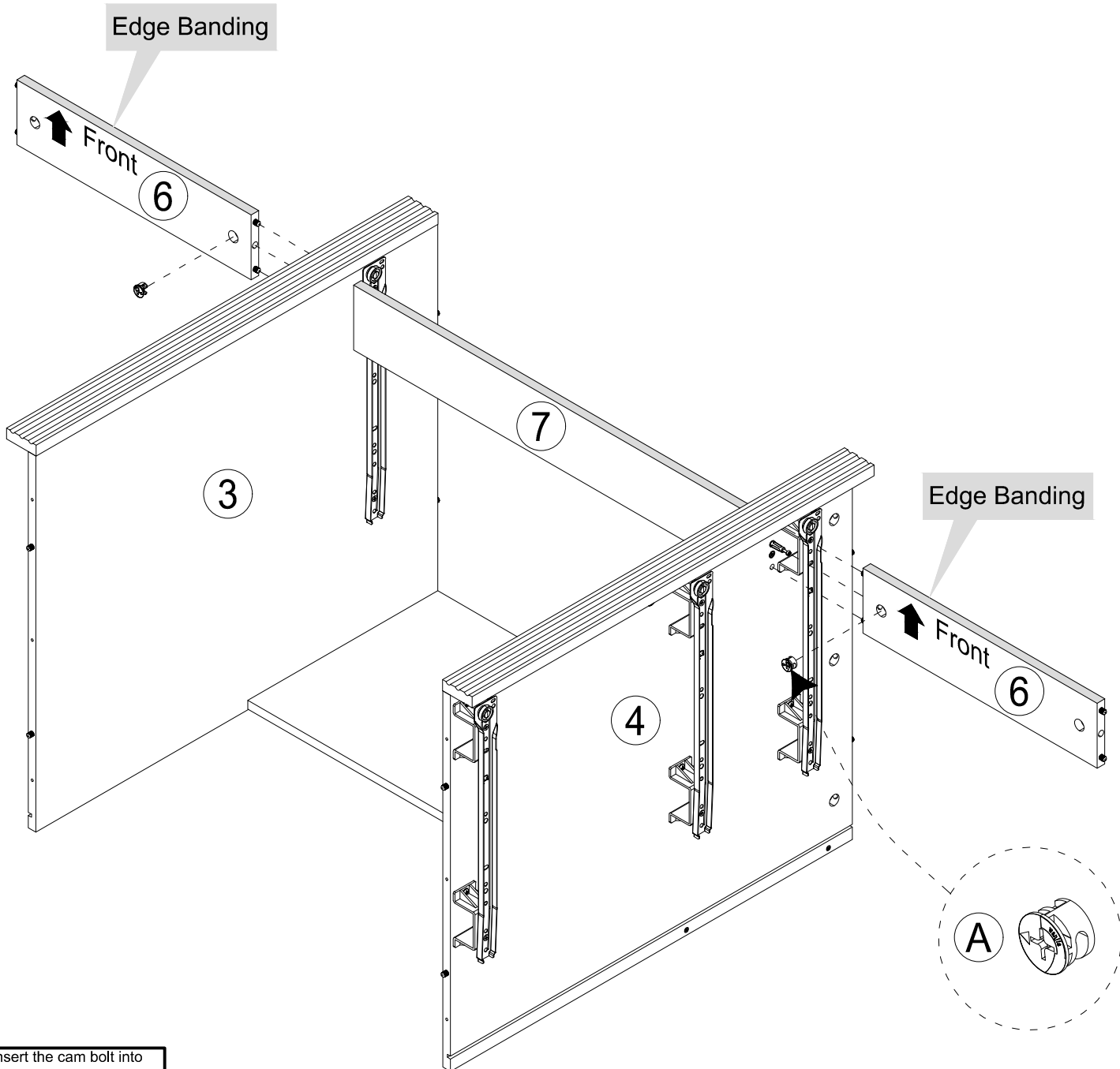
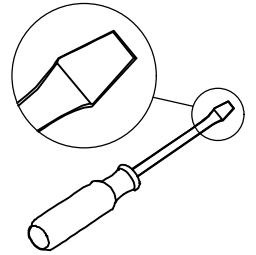
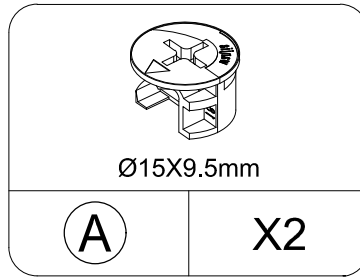

Insert the cam bolt into the hole first, then insert the cam lock and lock it.

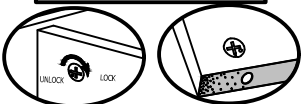

Proper orientation of CAM LOCK

Assembly Instructions

STEP 22

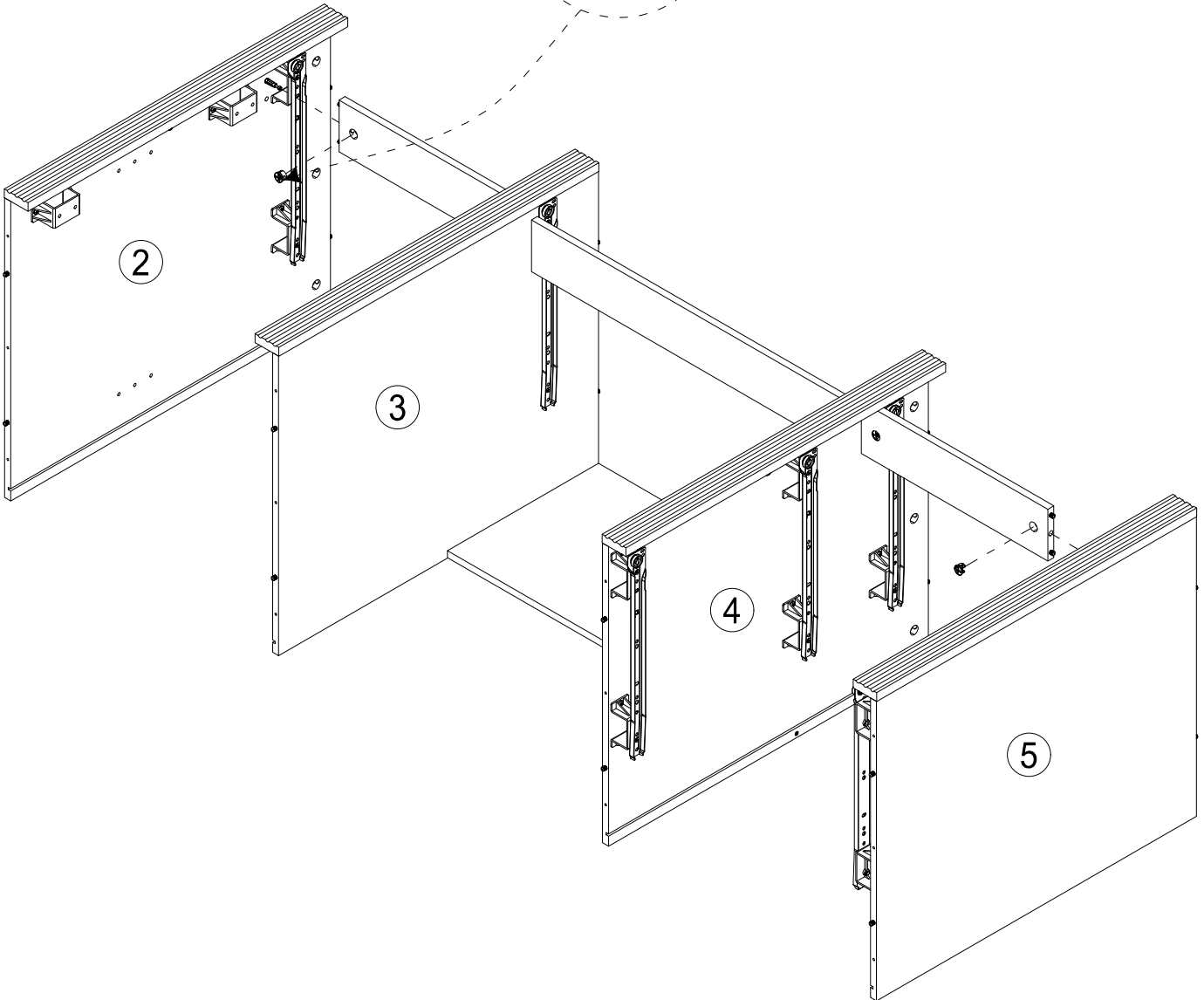
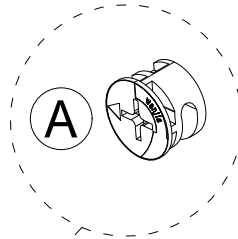
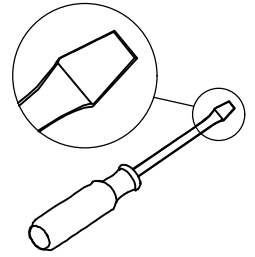
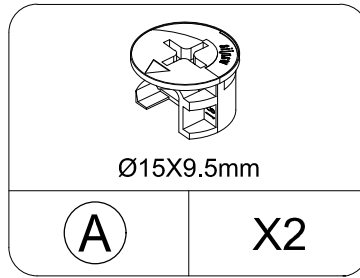

Insert the cam bolt into the hole first, then insert the cam lock and lock it.

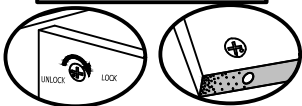

Proper orientation of CAM LOCK

Assembly Instructions

STEP 23

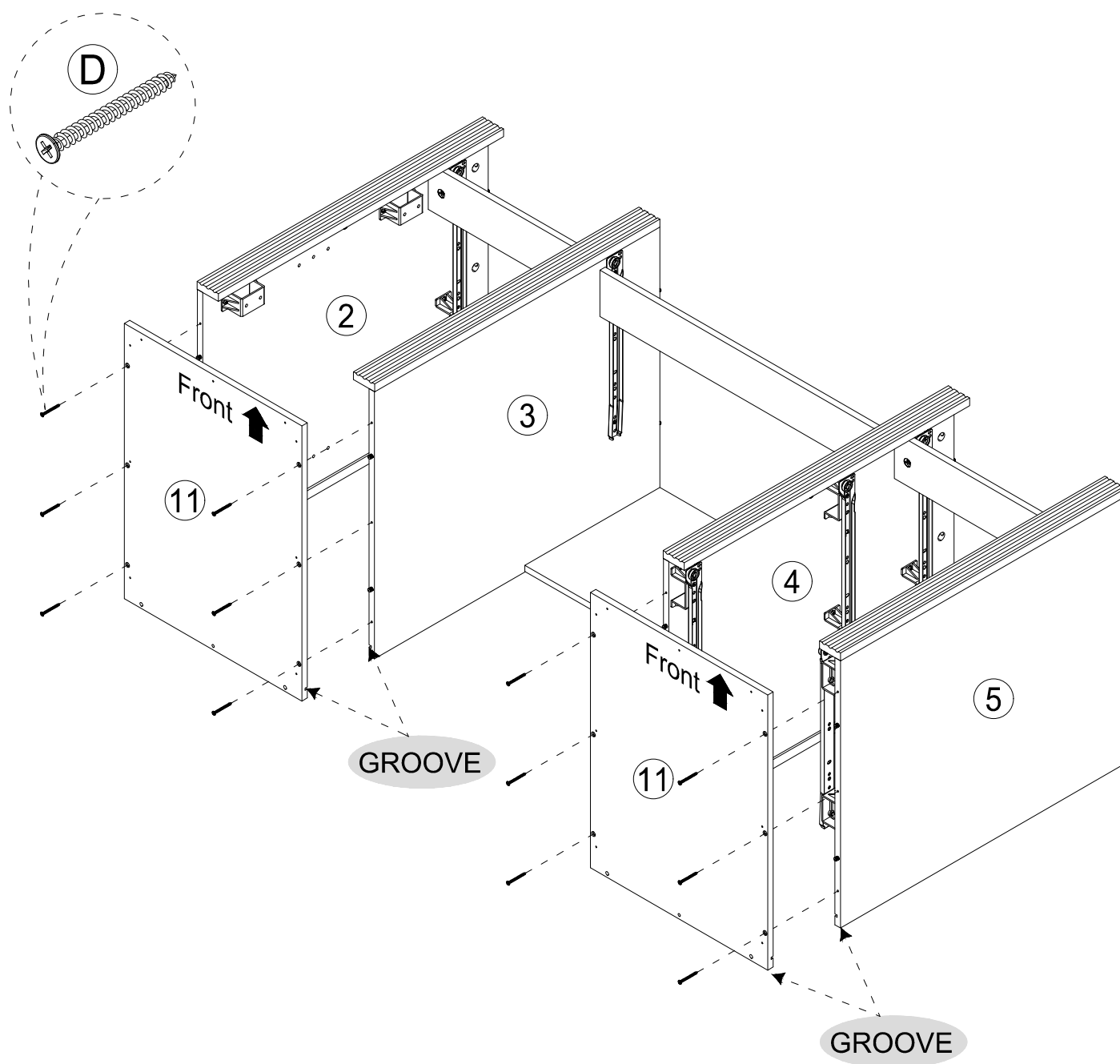
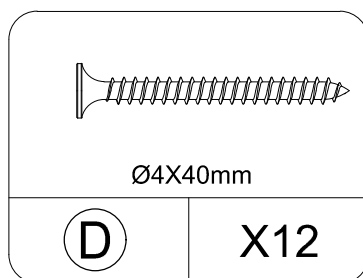
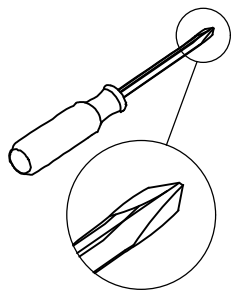

Assembly Instructions

STEP 24

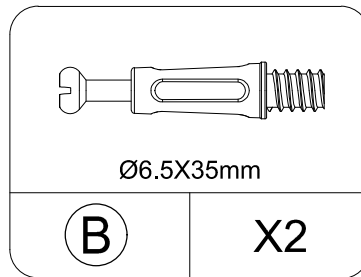
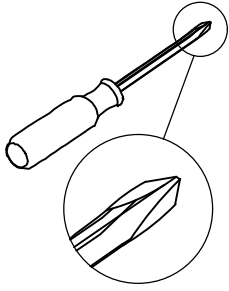

This step requires two people to stand the cabinet up and install it.

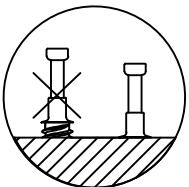
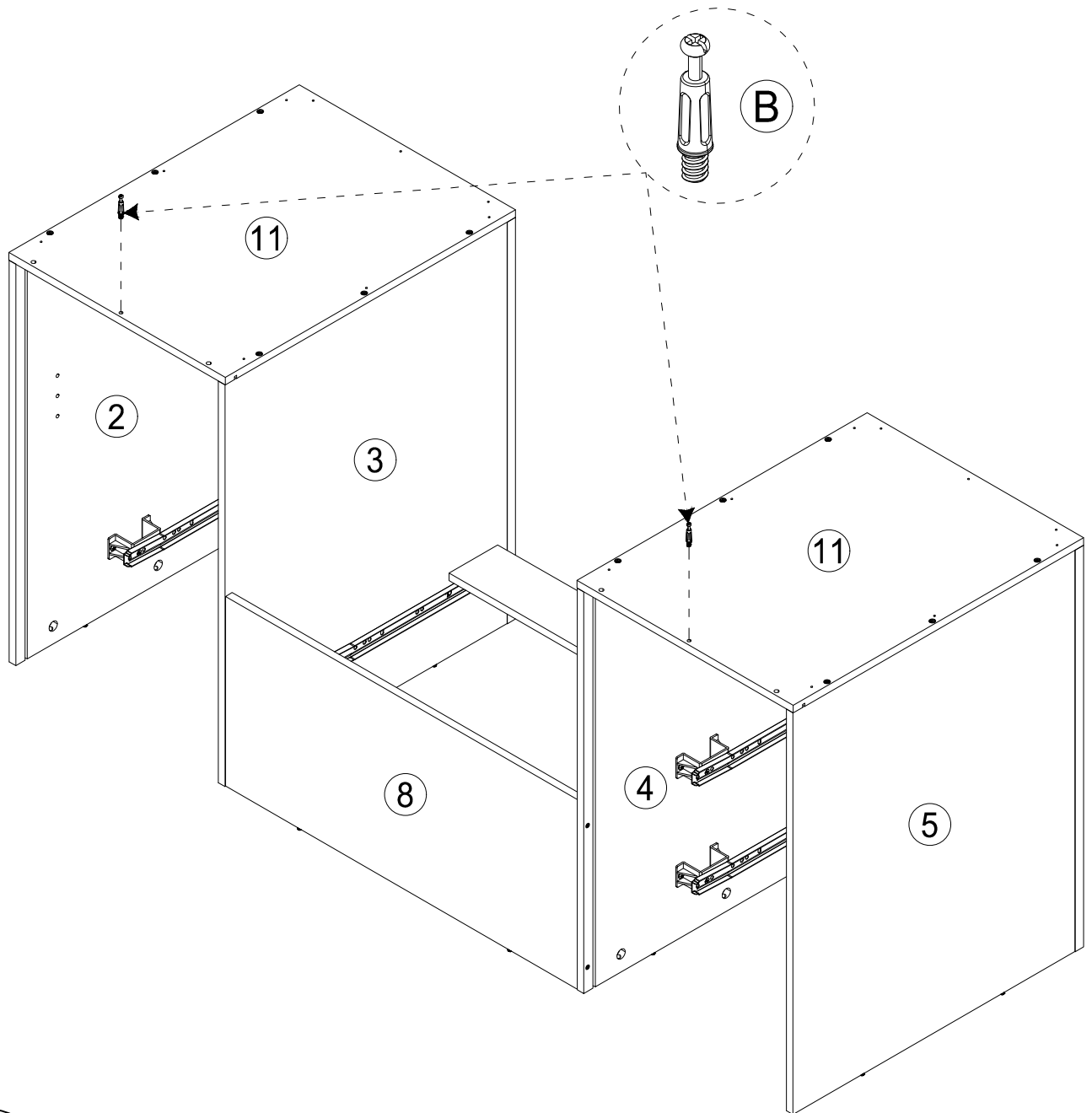

Assembly Instructions

STEP 25

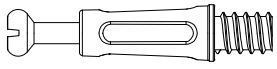

Ø6.5X35mm

(B)

X8

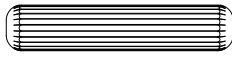

Ø6X30mm

(C)

X12

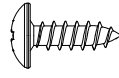

Ø4X12mm

(F)

X18

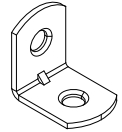

20X20X16mm

(L)

X18

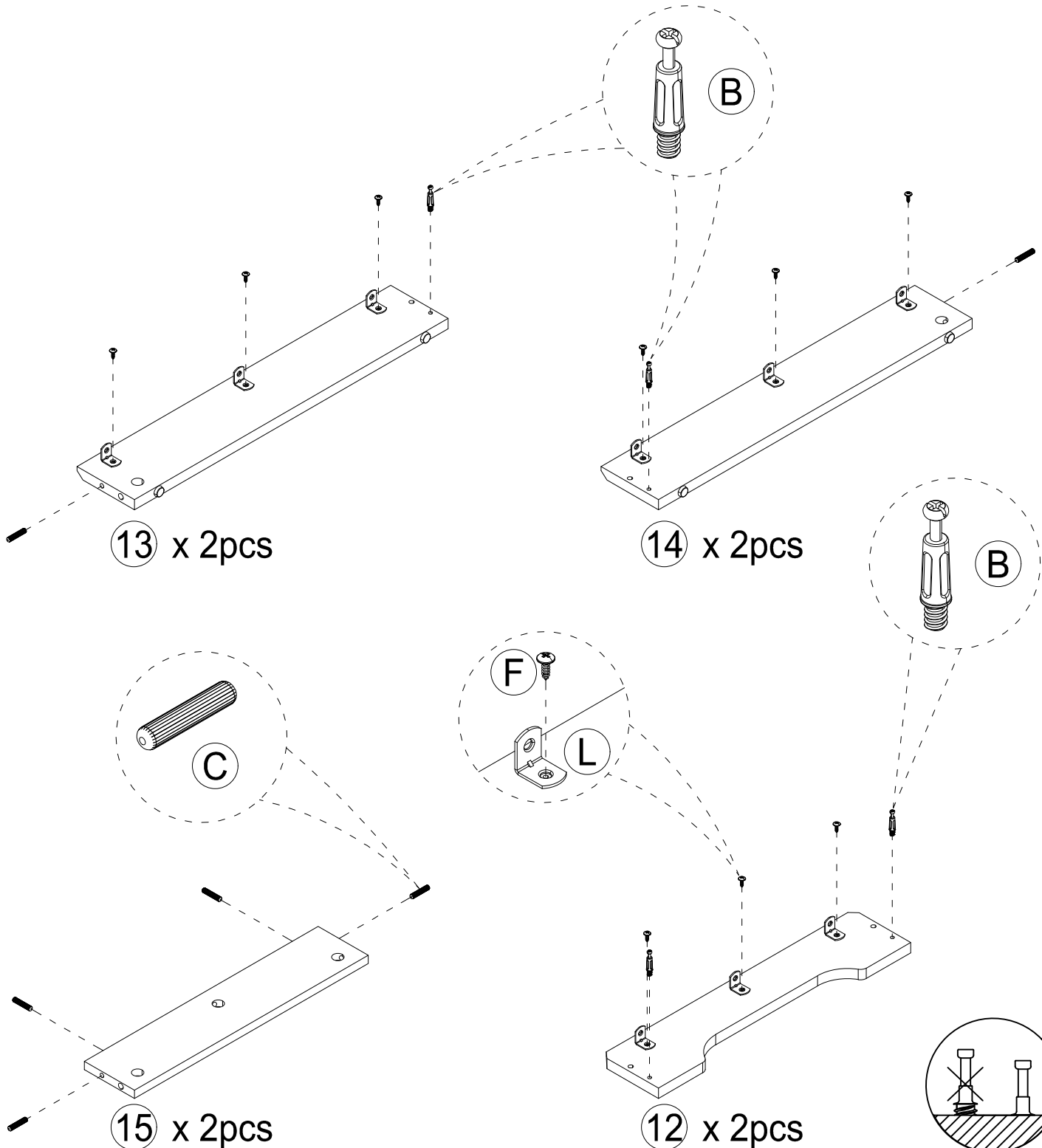

Assembly Instructions

STEP 26

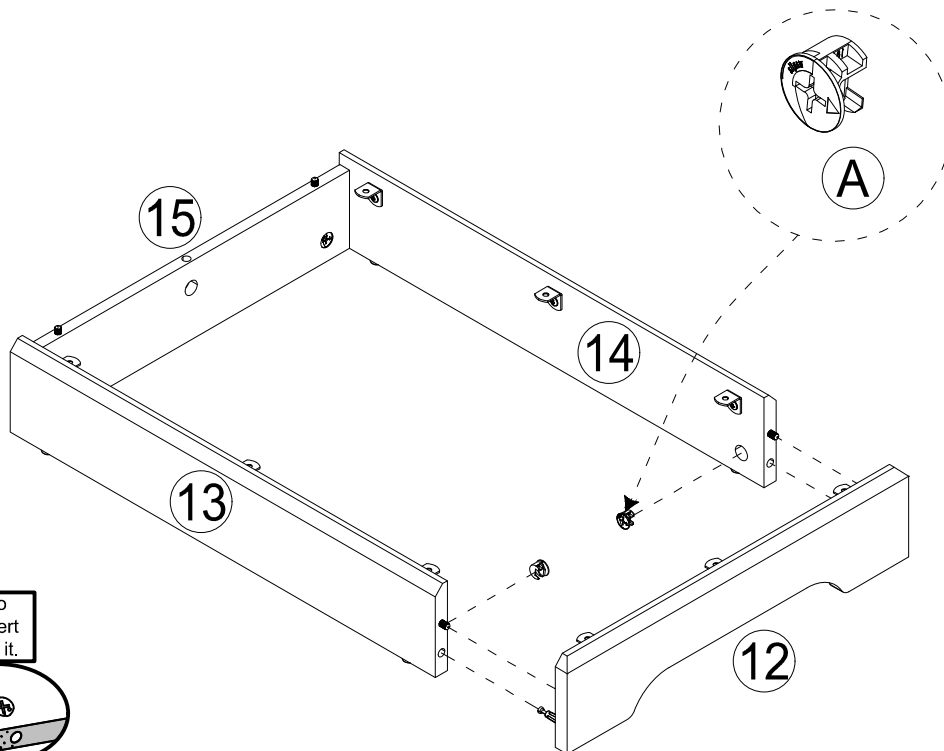
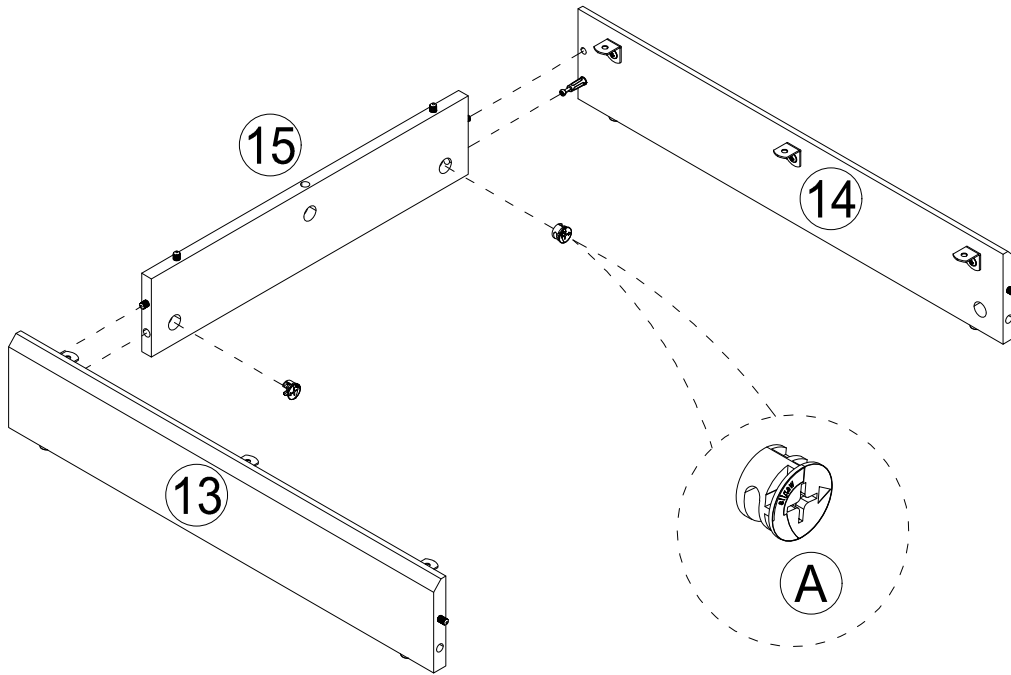
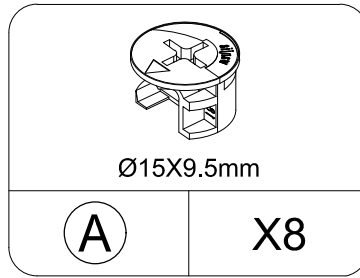
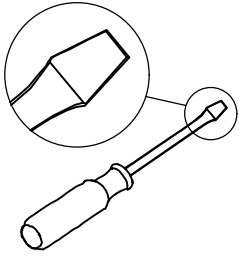

Insert the cam bolt into the hole first, then insert the cam lock and lock it.

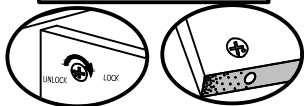

x 2

Assembly Instructions

STEP 27

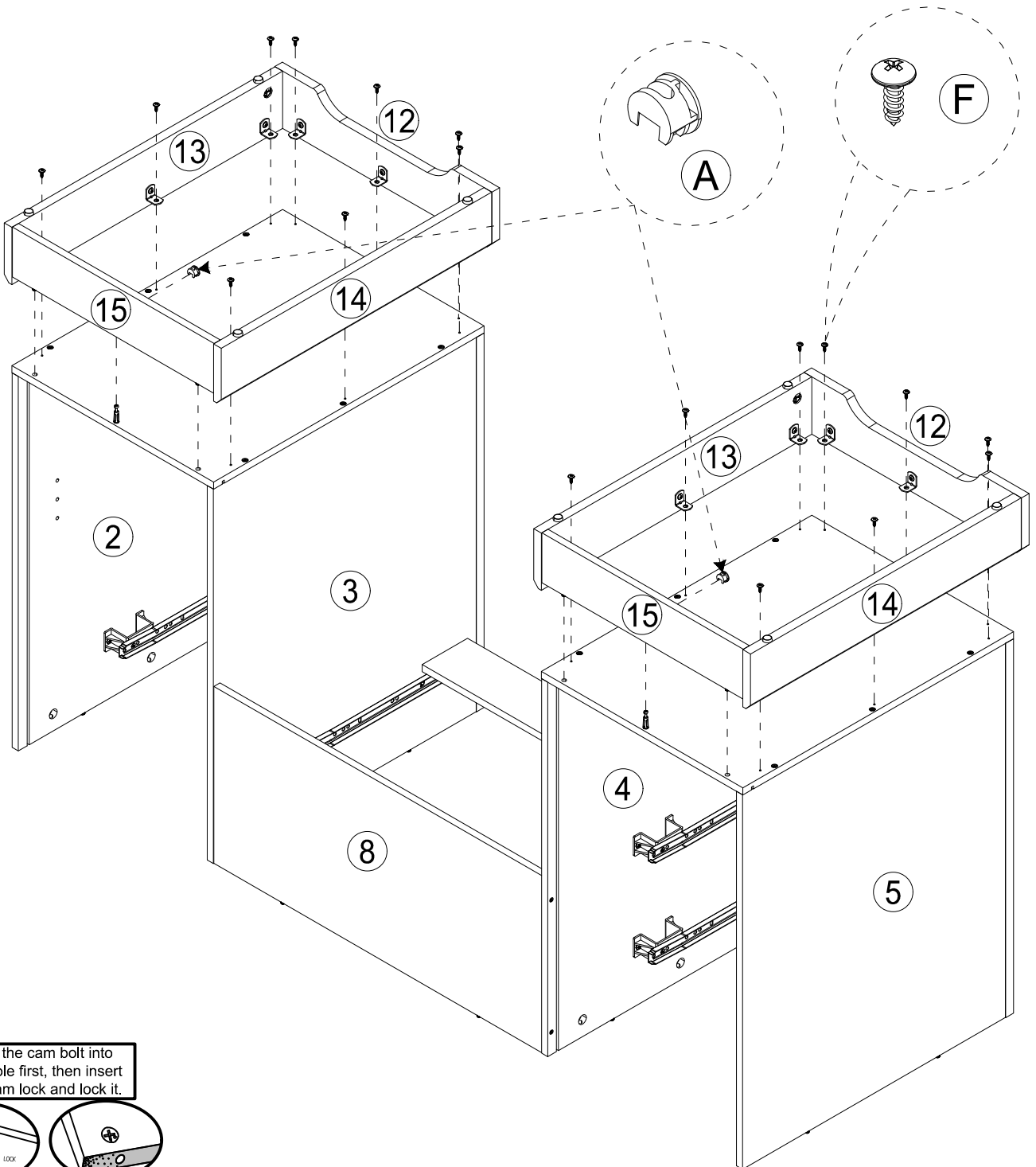
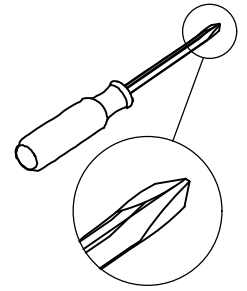
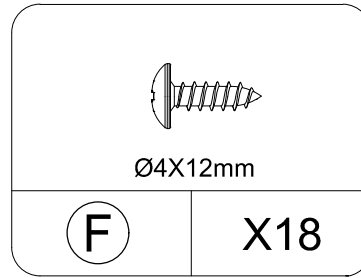
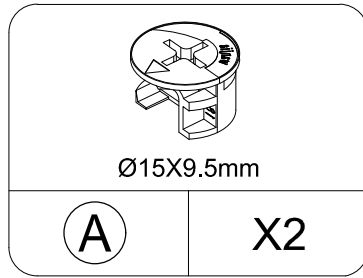
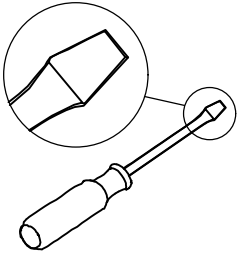

Insert the cam bolt into the hole first, then insert the cam lock and lock it.

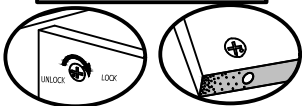

Assembly Instructions

STEP 28

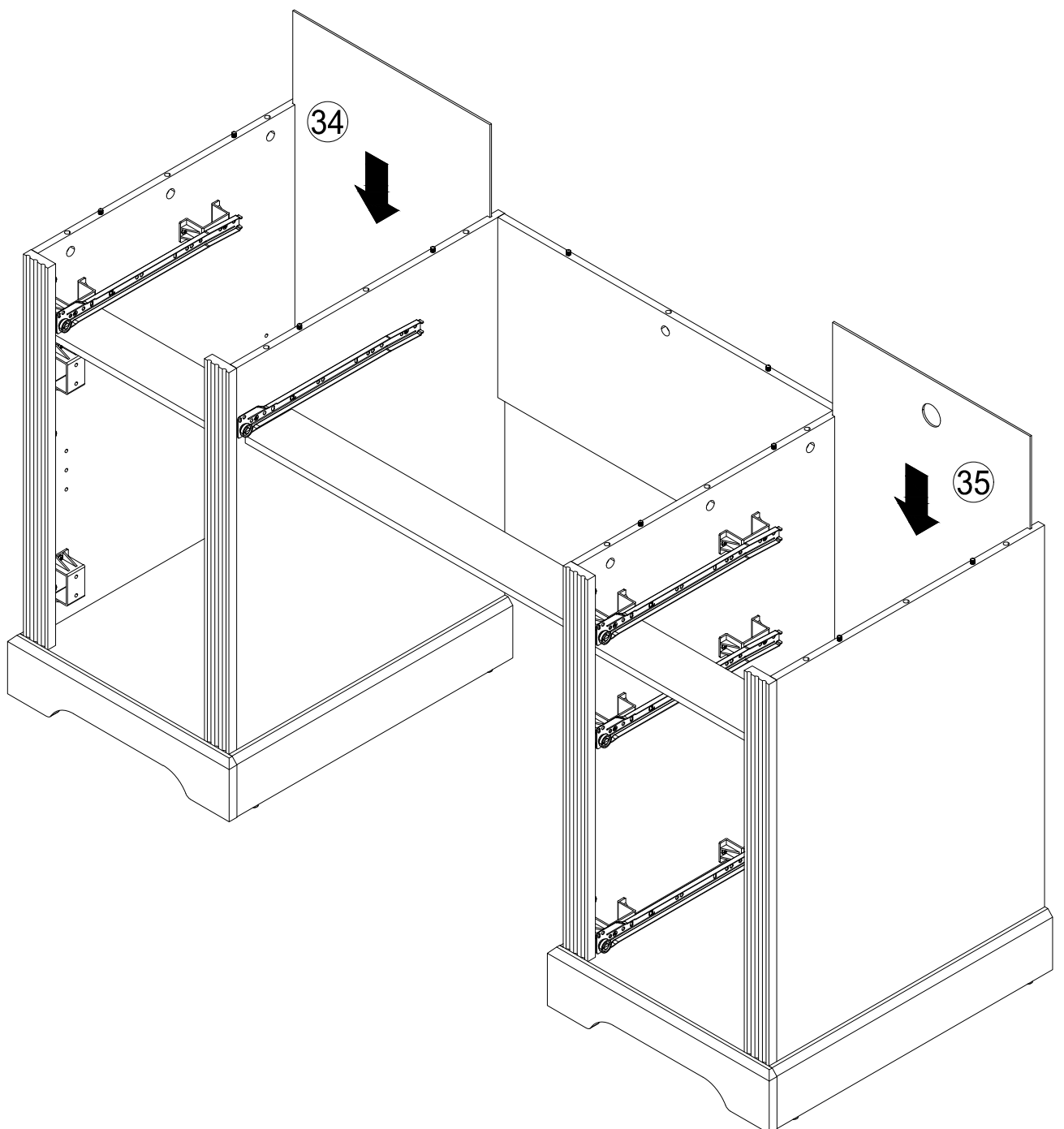

Assembly Instructions

STEP 29

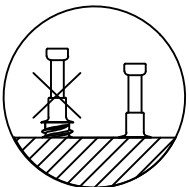
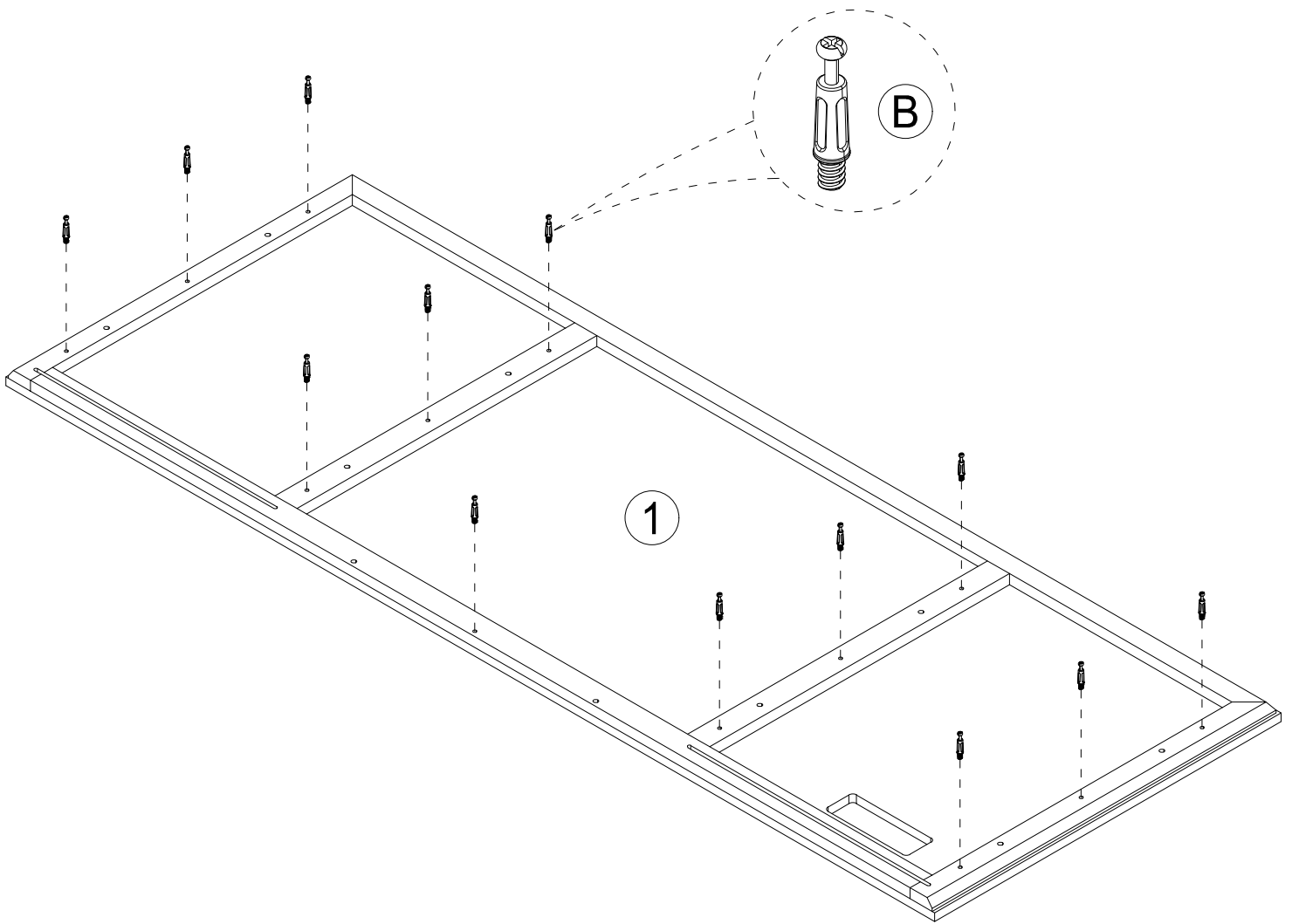
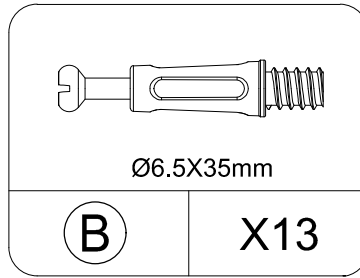
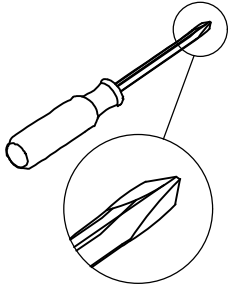

Assembly Instructions

STEP 30

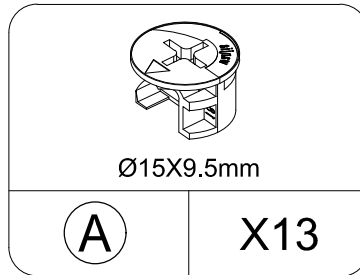
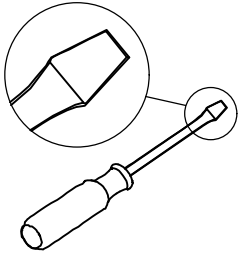

THIS STEP REQUIRES 2 PEOPLE

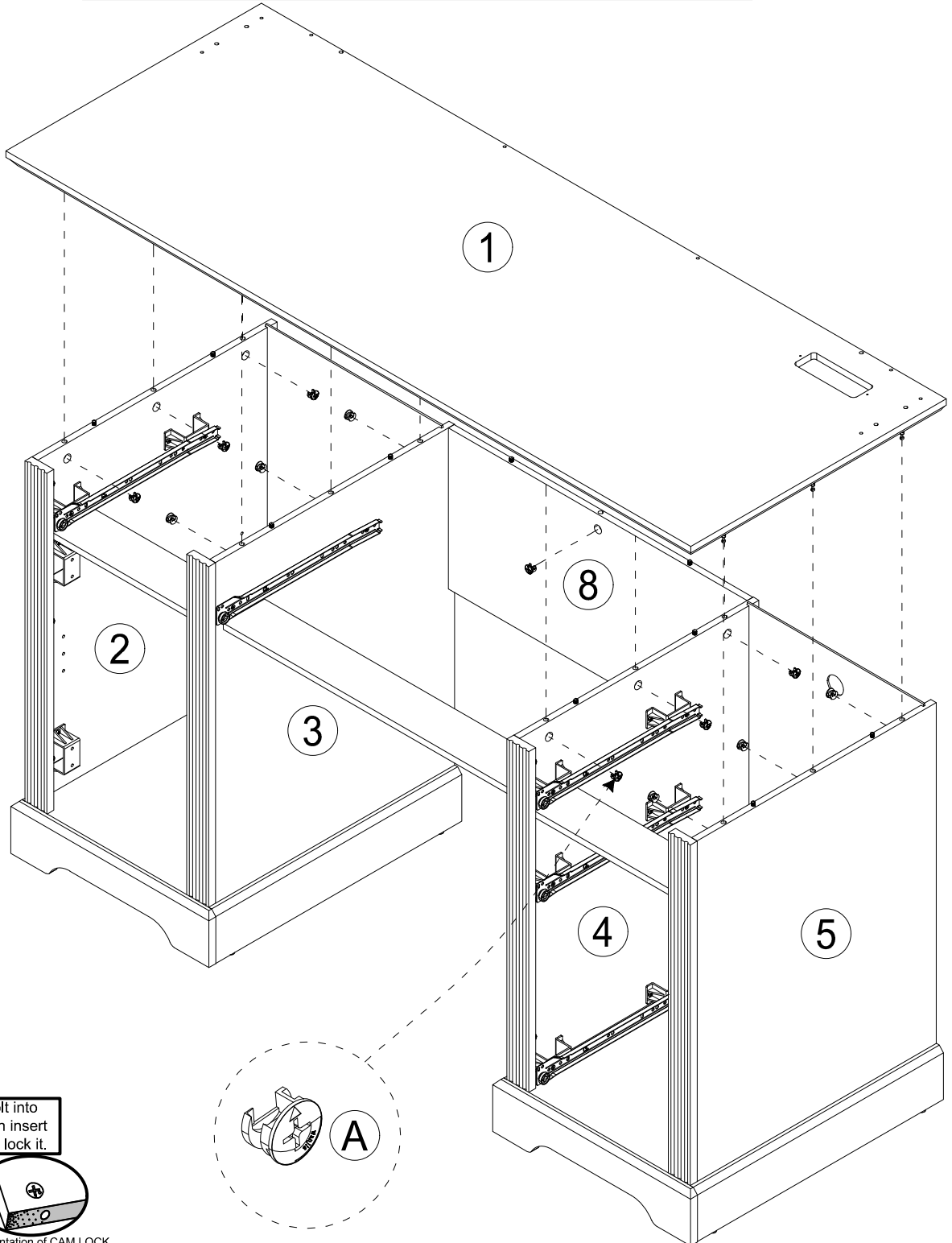

Assembly Instructions

STEP 31

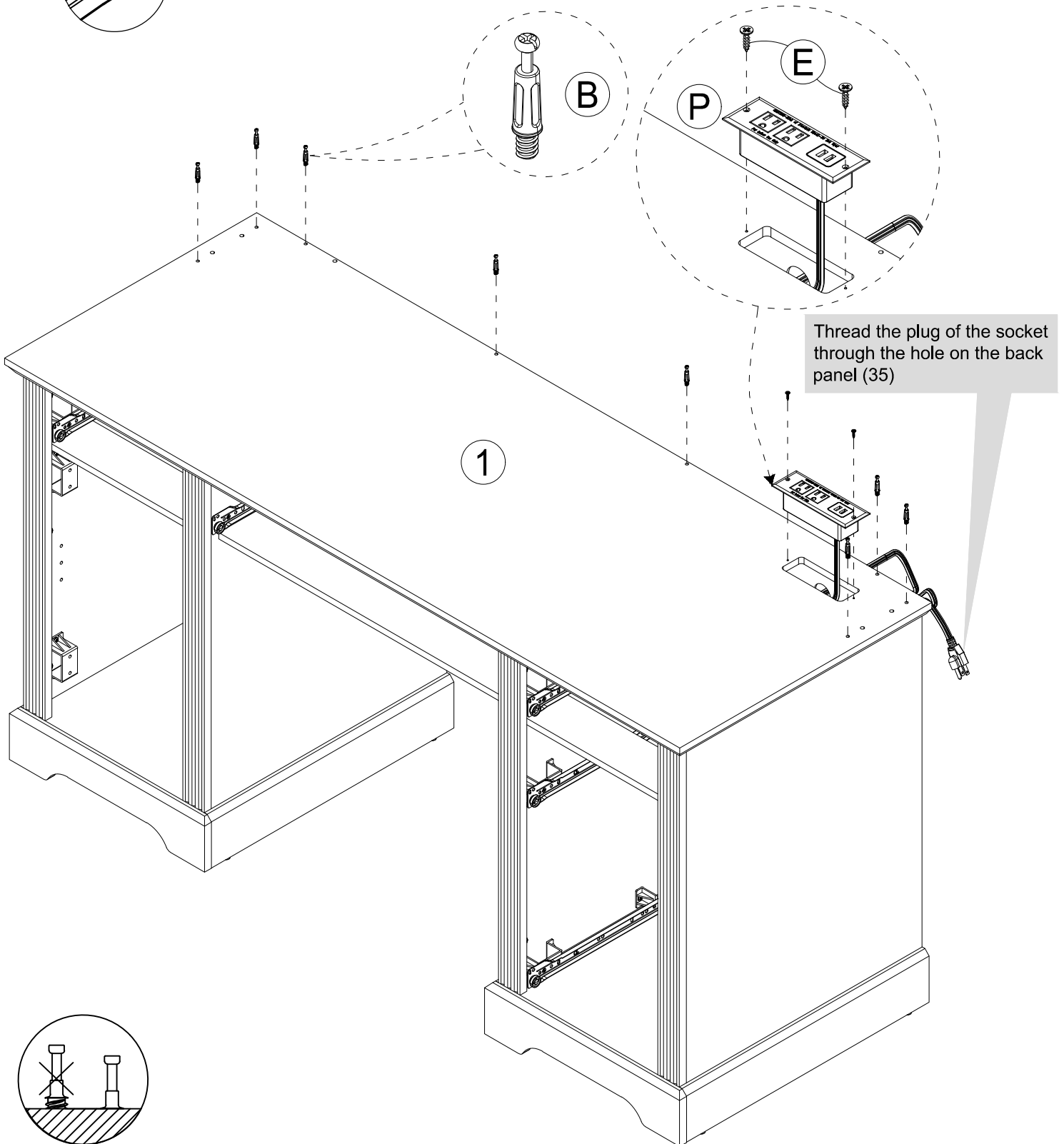
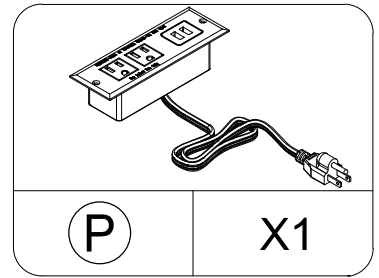
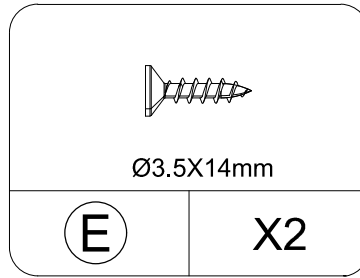
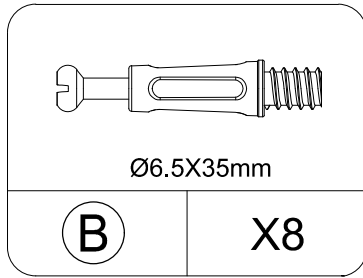
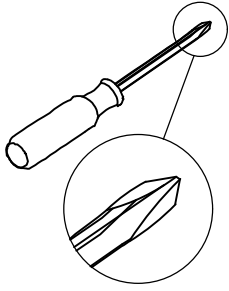

Assembly Instructions

STEP 32

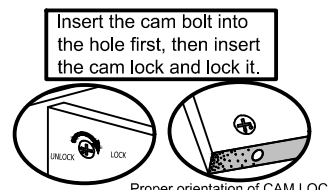
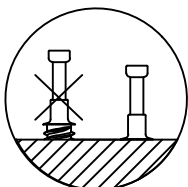
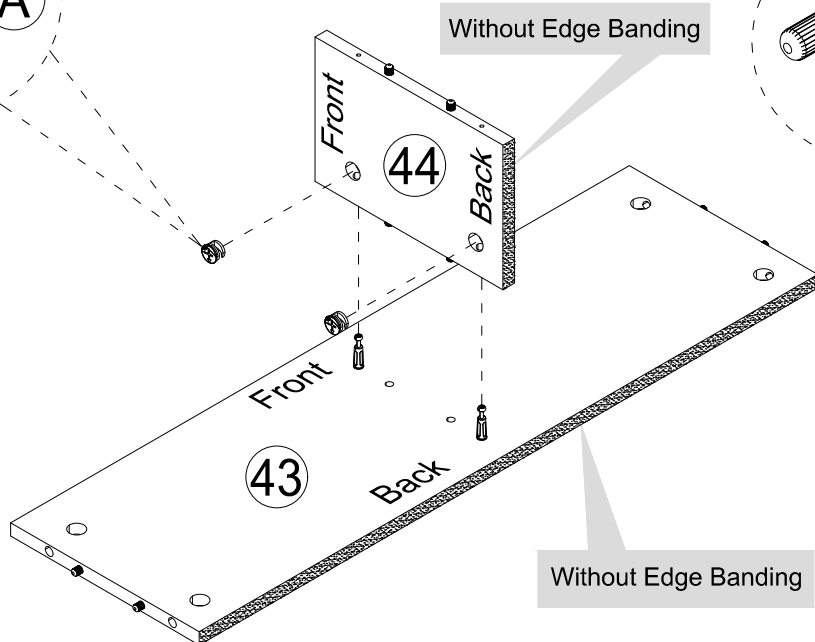
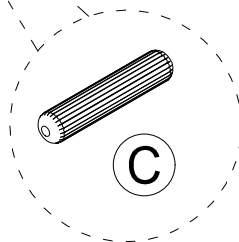
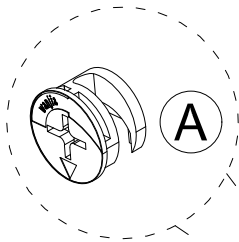
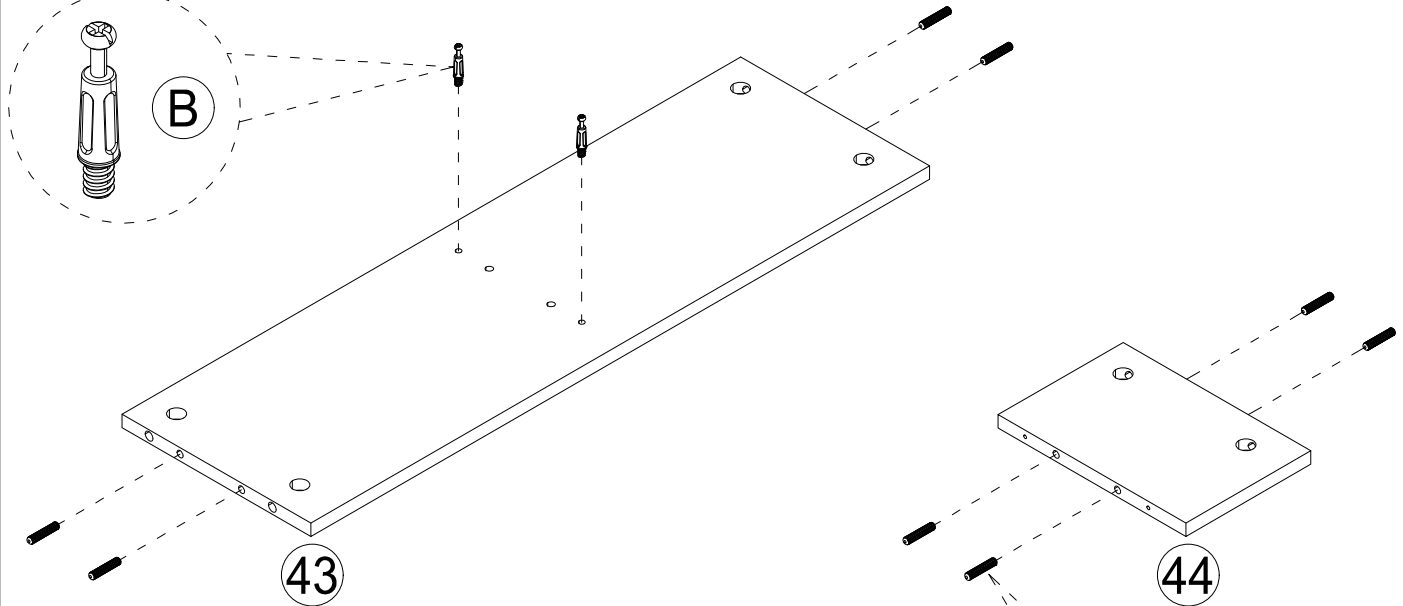
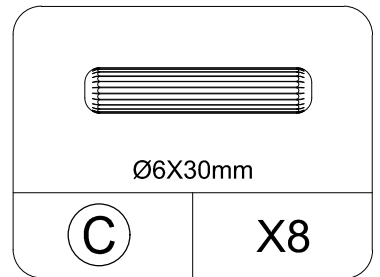
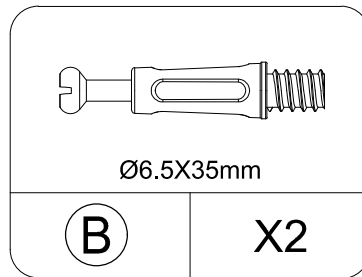
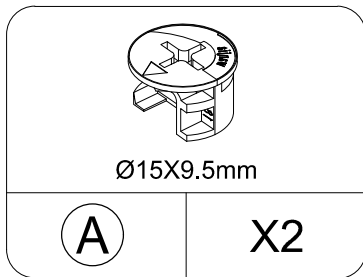
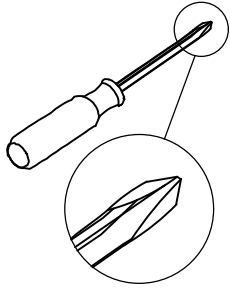

Assembly Instructions

STEP 33

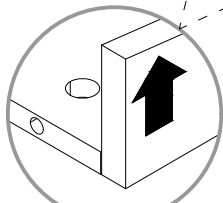
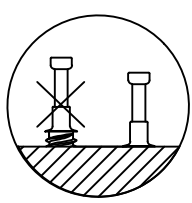
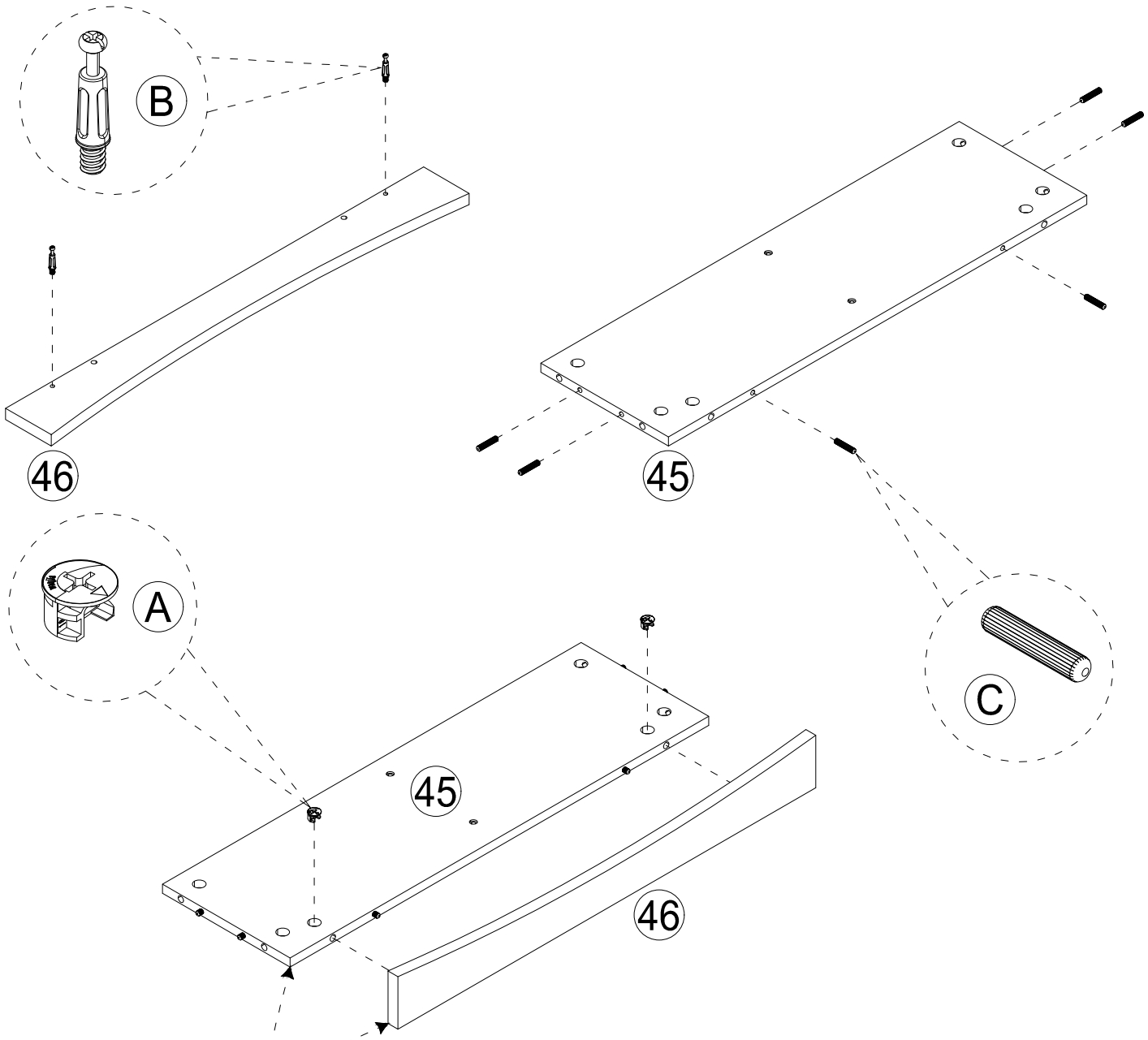
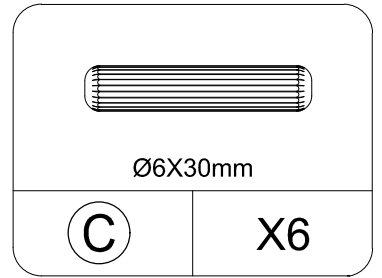
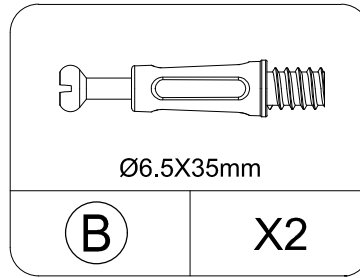
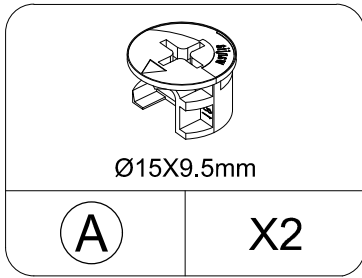
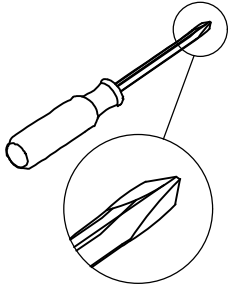

After assembly effect

Insert the cam bolt into the hole first, then insert the cam lock and lock it.

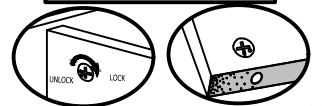

Proper orientation of CAM LOCK

Assembly Instructions

STEP 34

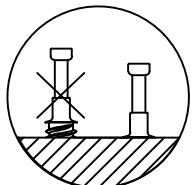
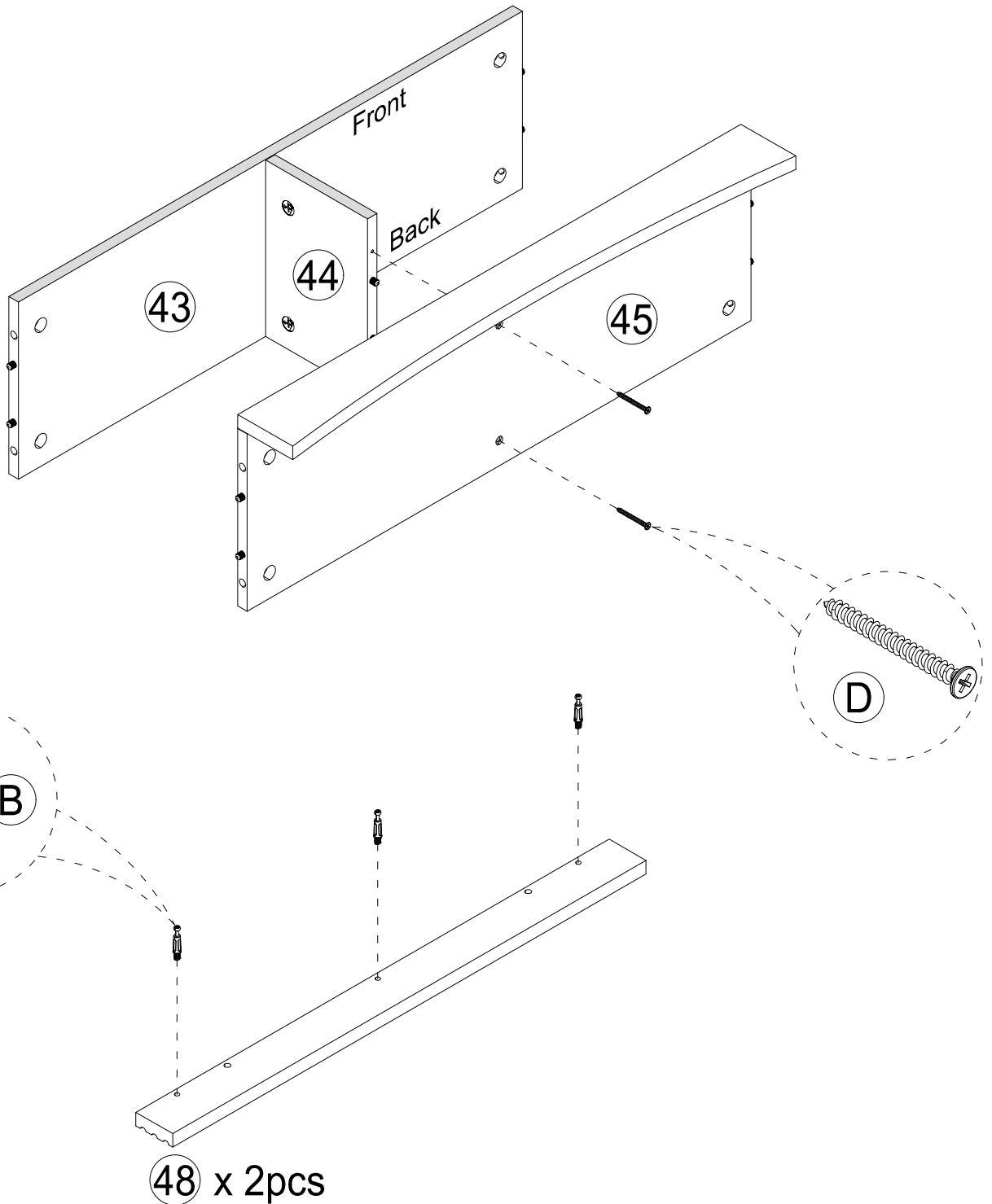
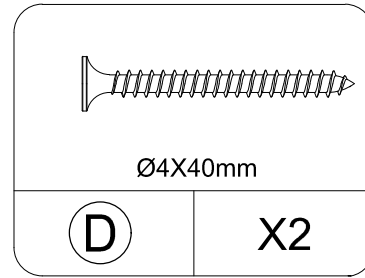
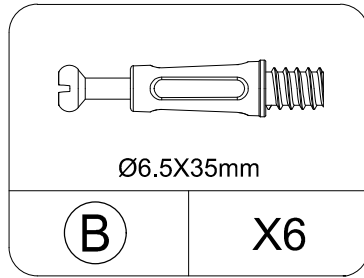
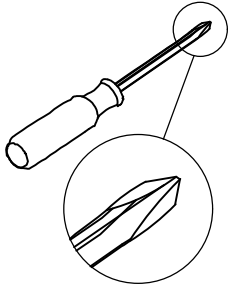

Assembly Instructions

STEP 35

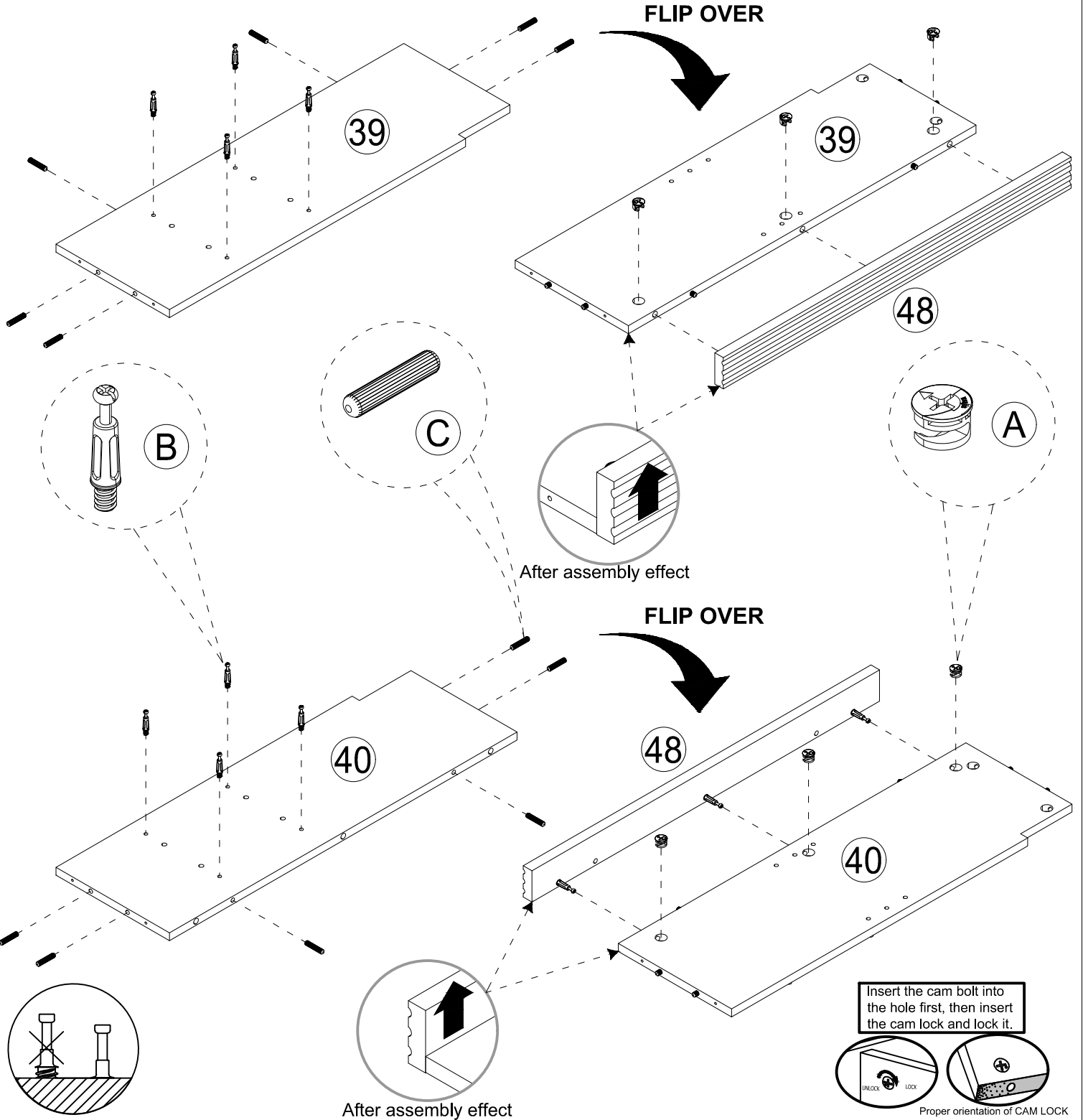
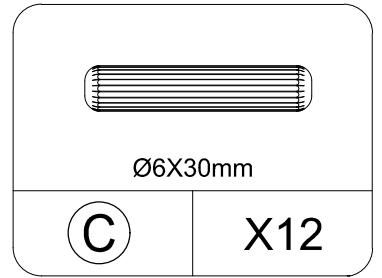
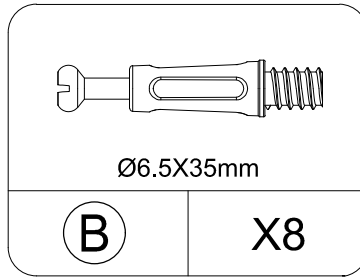
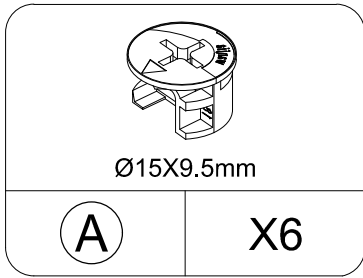
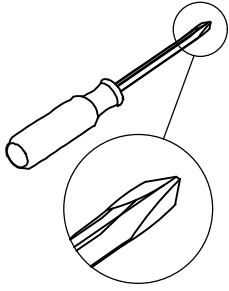

Assembly Instructions

STEP 36

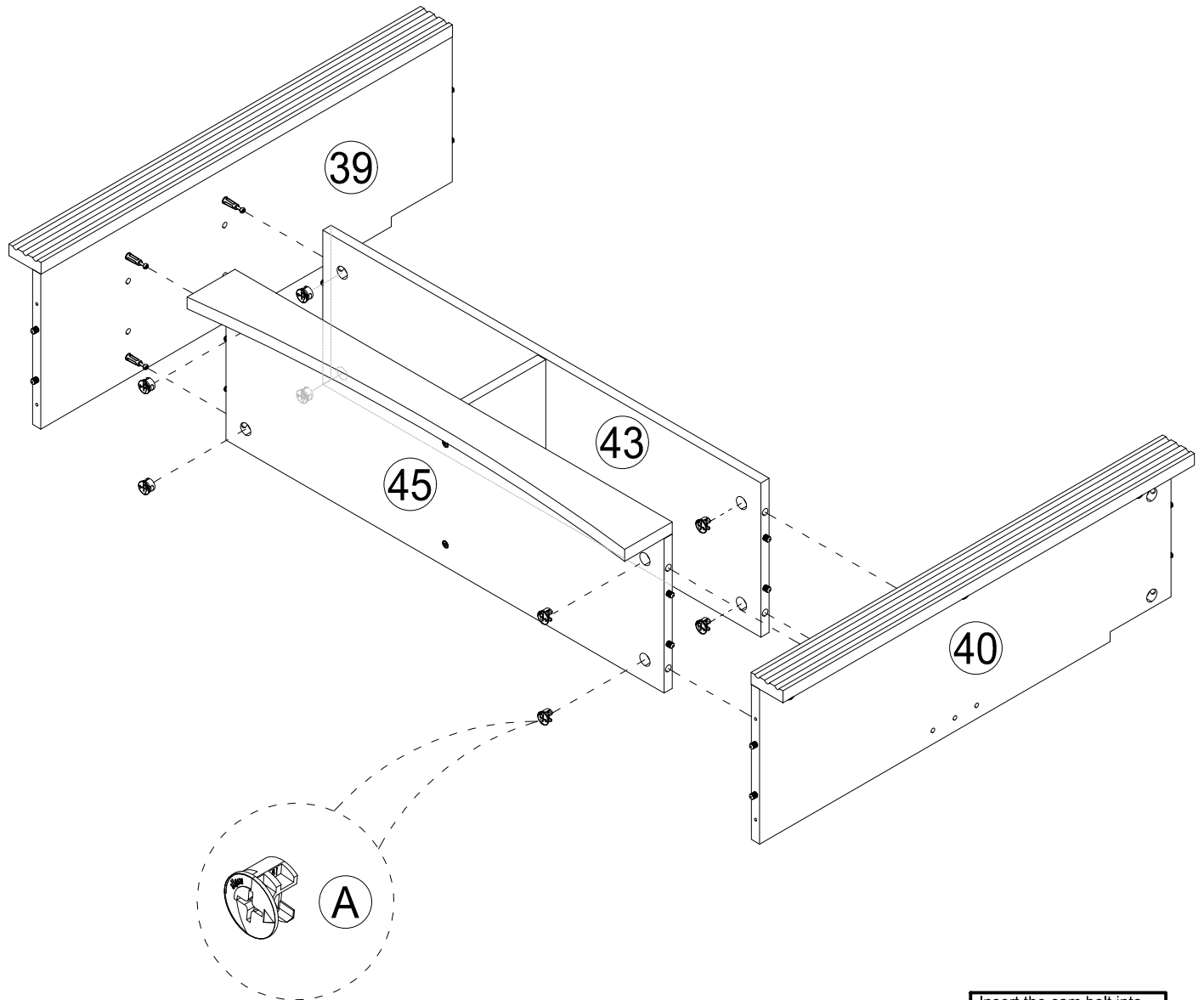
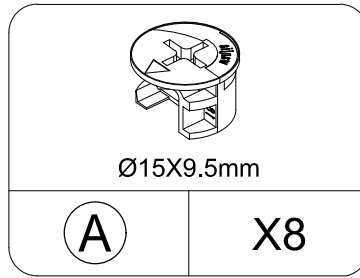
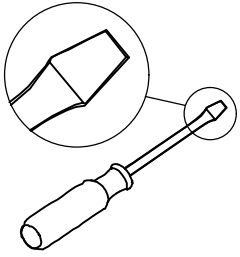

Insert the cam bolt into the hole first, then insert the cam lock and lock it.

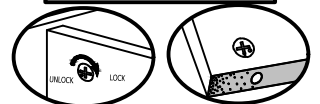

Proper orientation of CAM LOCK

Assembly Instructions

STEP 37

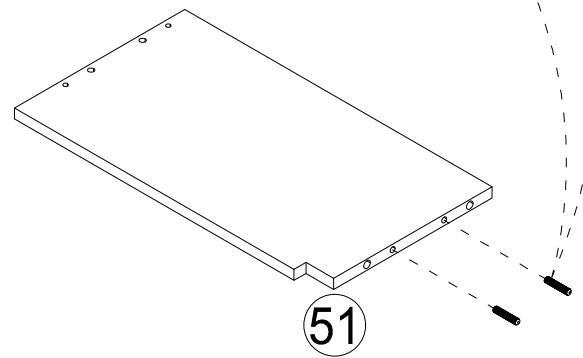
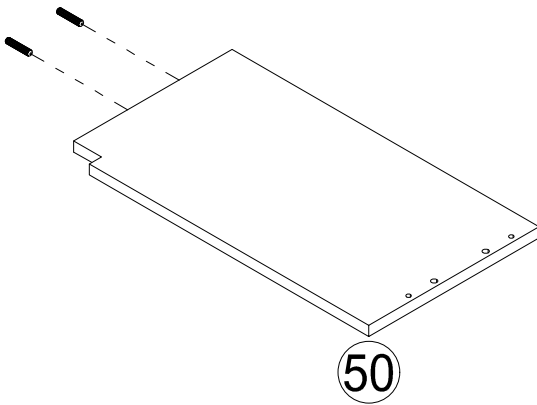
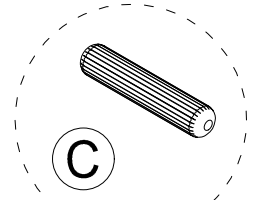
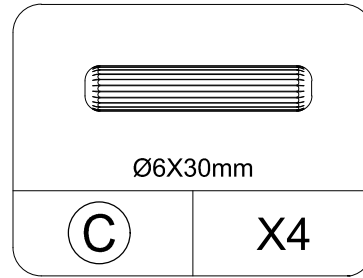
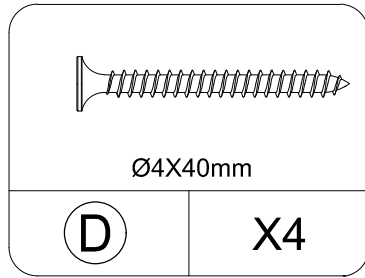
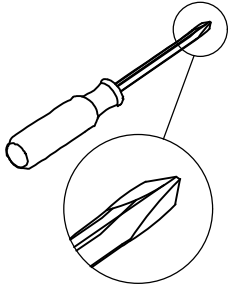

Pay attention to installing in the direction shown in the picture

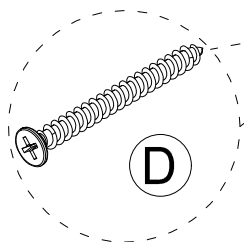
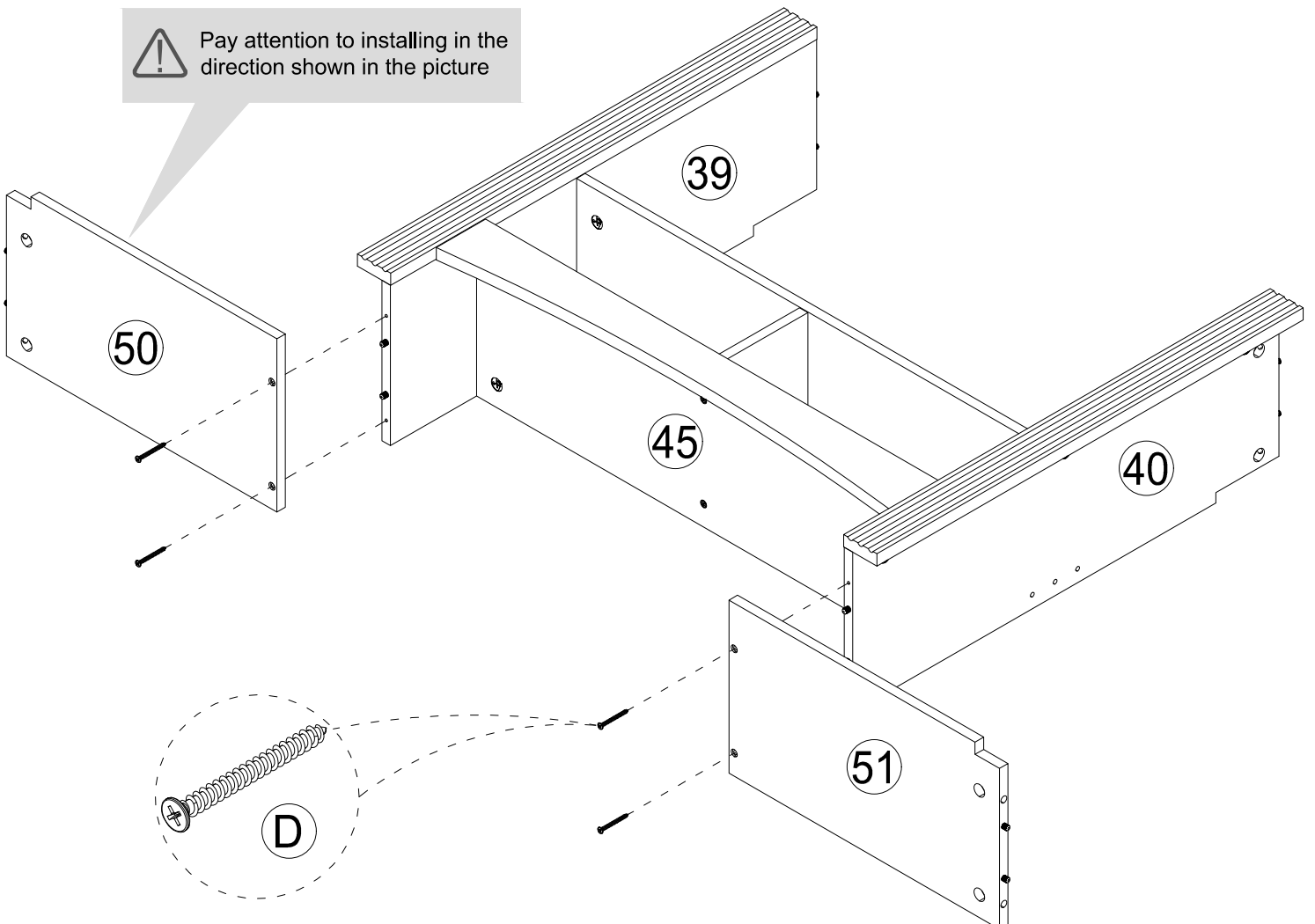

Assembly Instructions

STEP 38

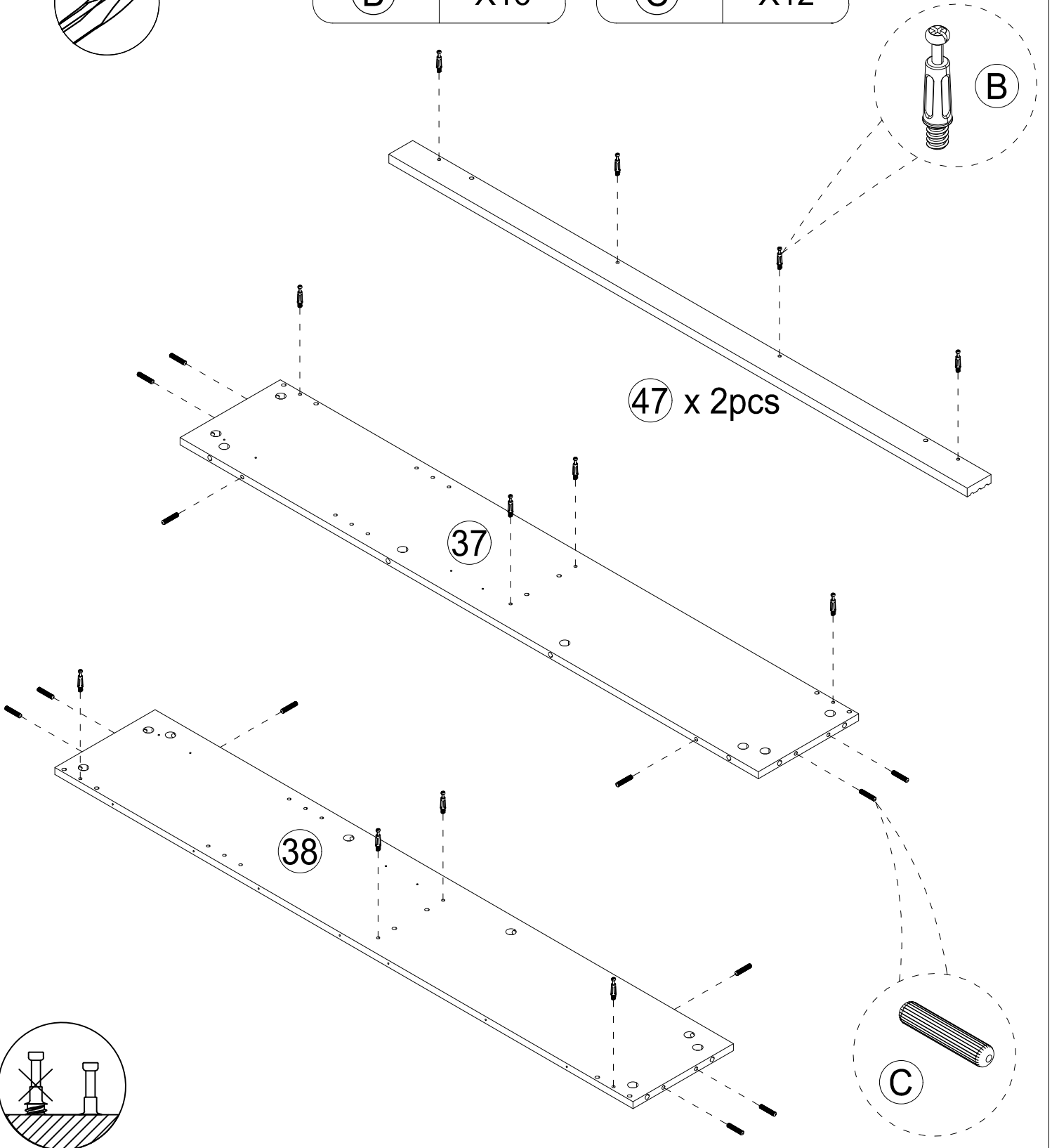
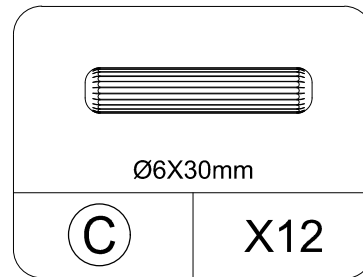
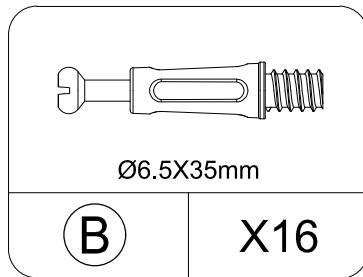
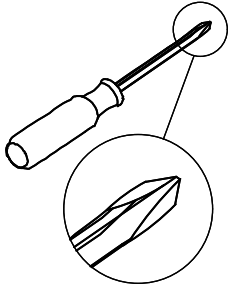

Assembly Instructions

STEP 39

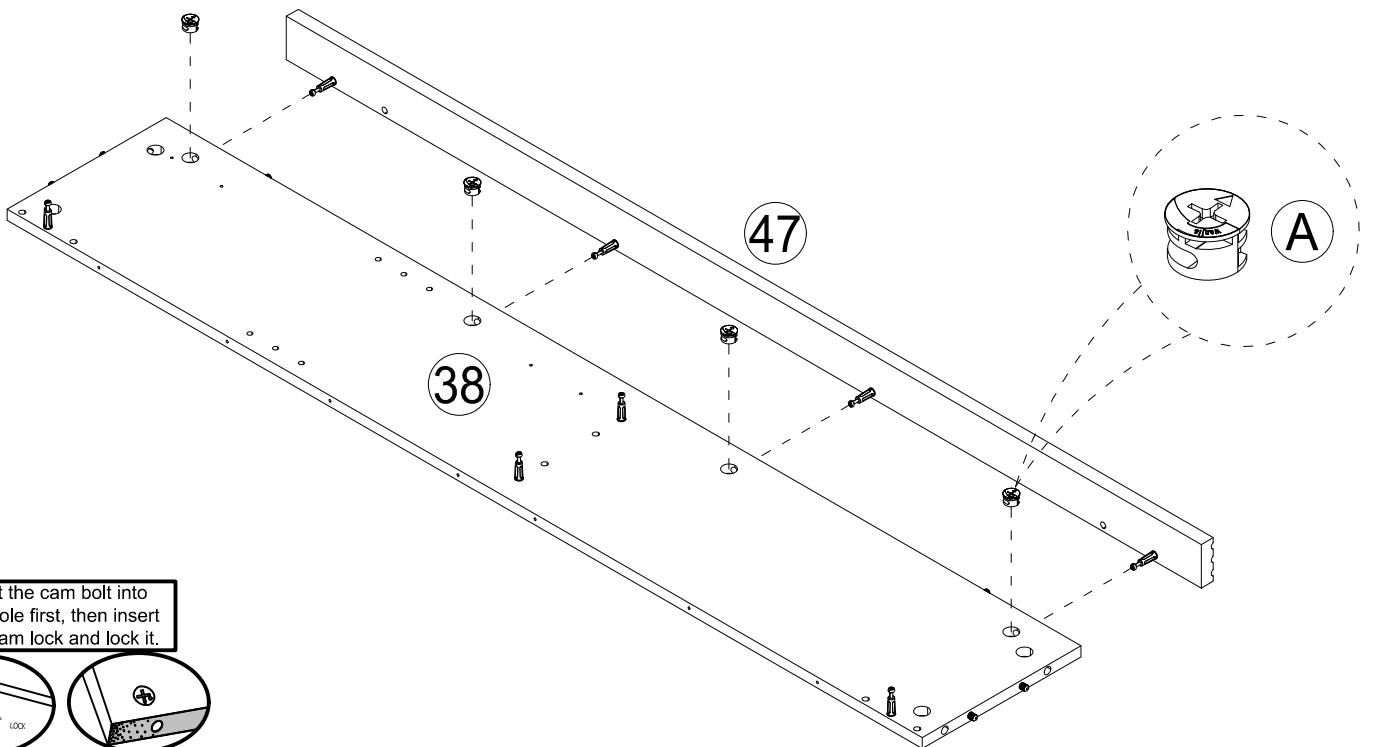
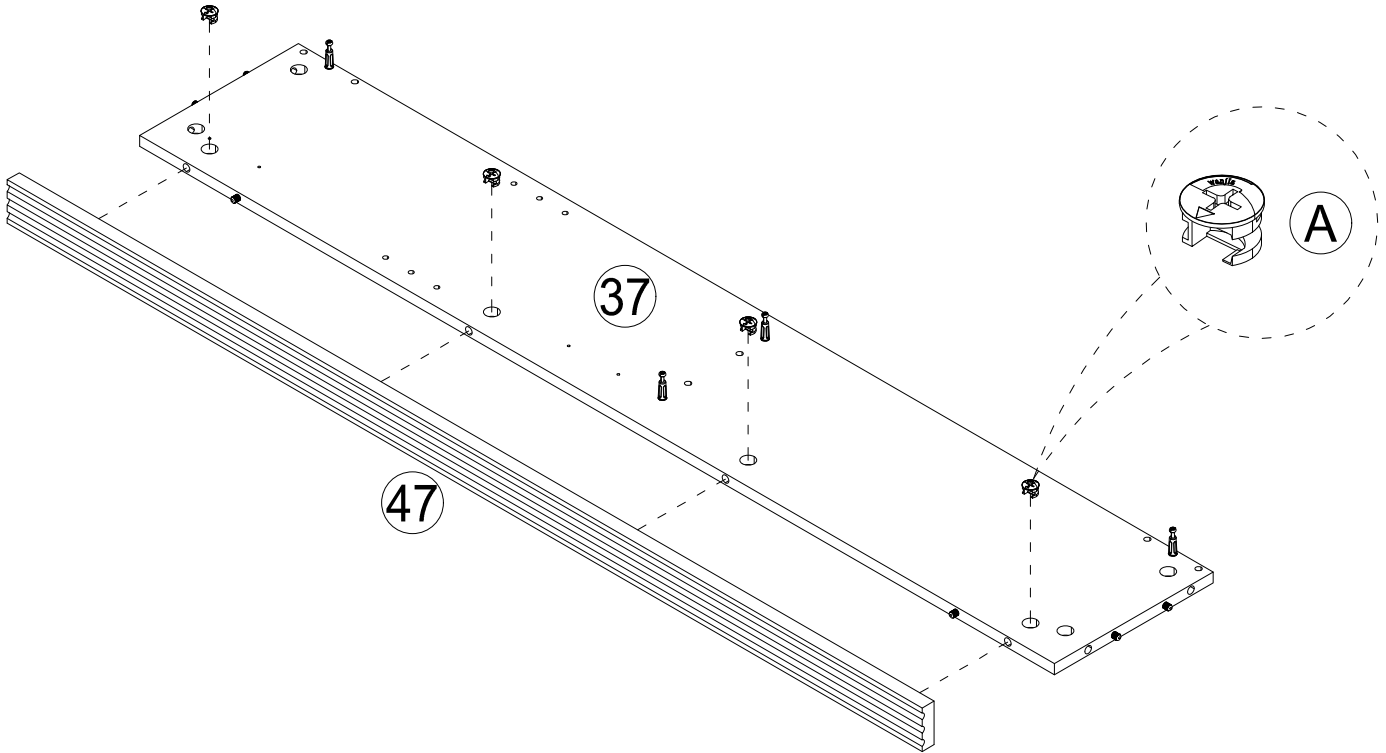
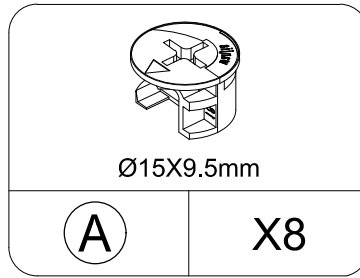
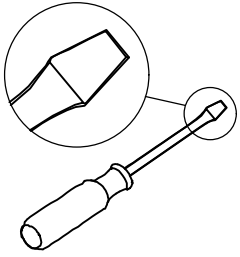

Insert the cam bolt into the hole first, then insert the cam lock and lock it.

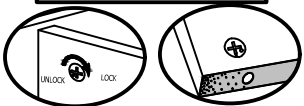

Assembly Instructions

STEP 40

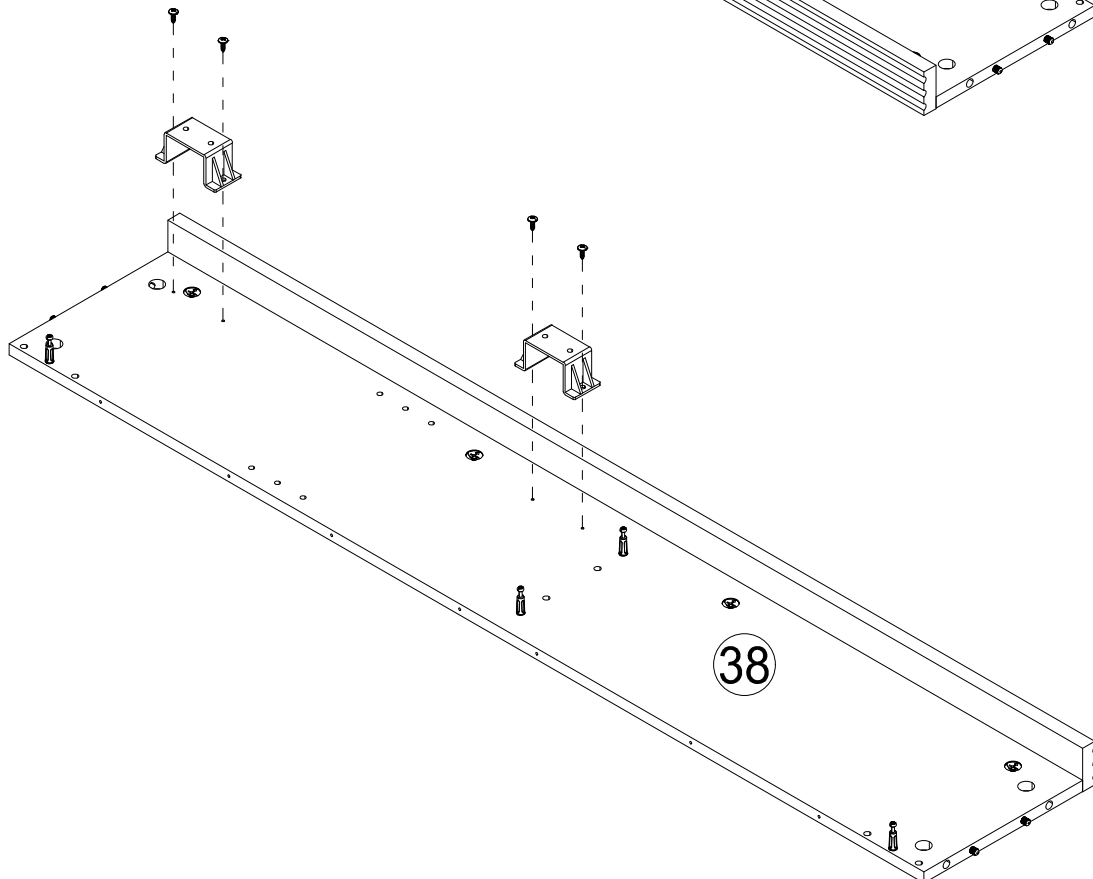
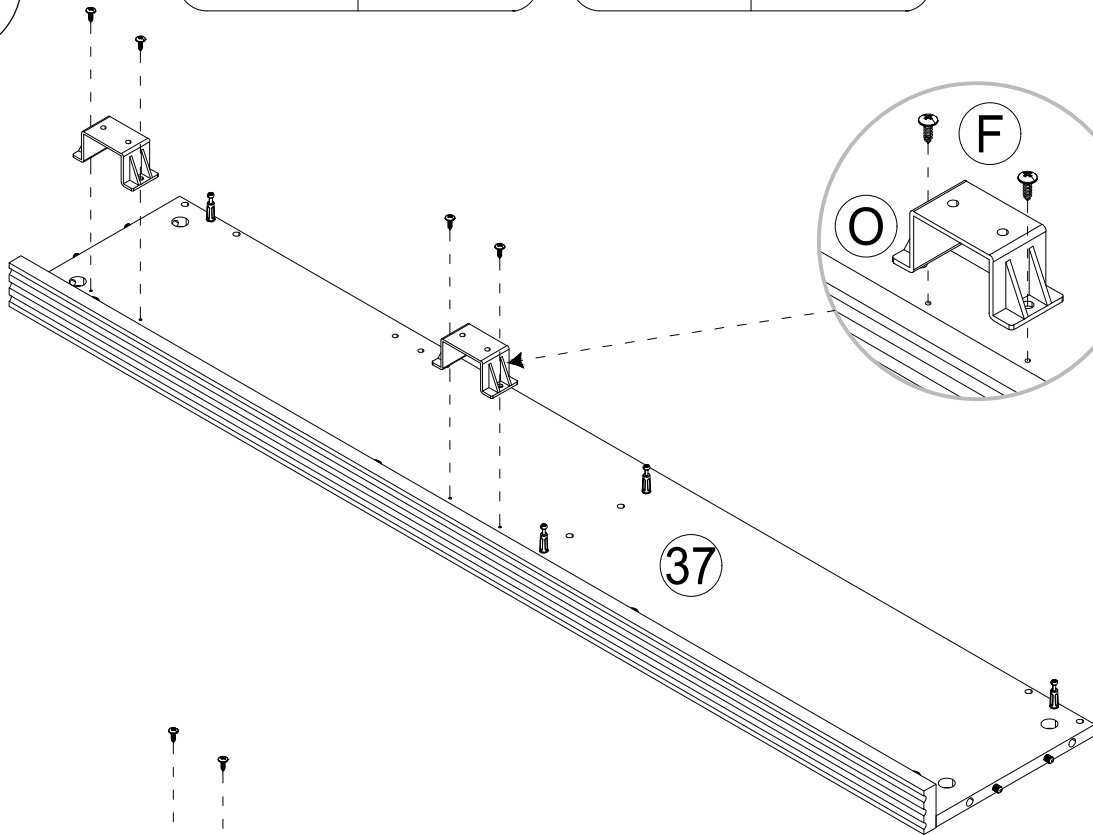
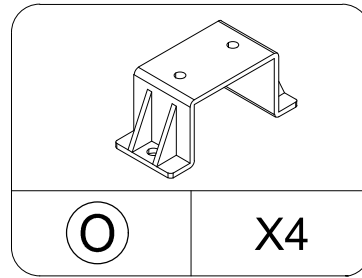
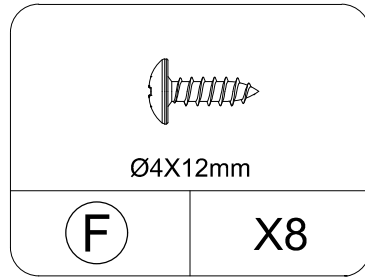
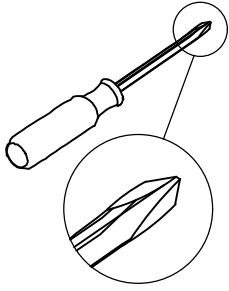

Assembly Instructions

STEP 41

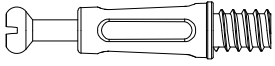

Ø6.5X35mm

(B)

X14

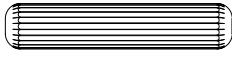

Ø6X30mm

(C)

X12

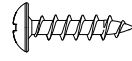

Ø3X14mm

(H)

X4

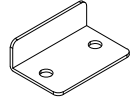

30X20X10mm

(S)

X2

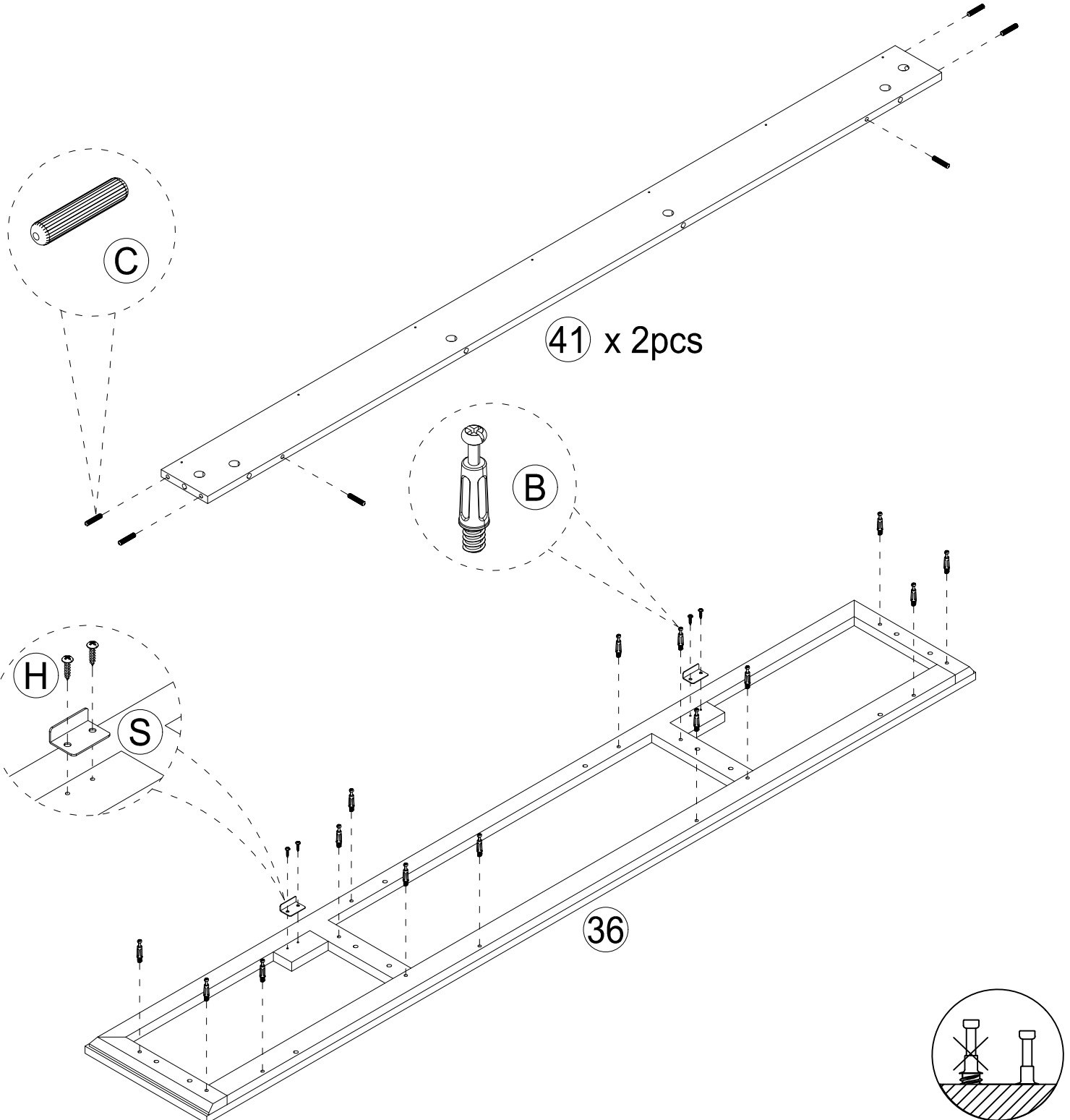

Assembly Instructions

STEP 42

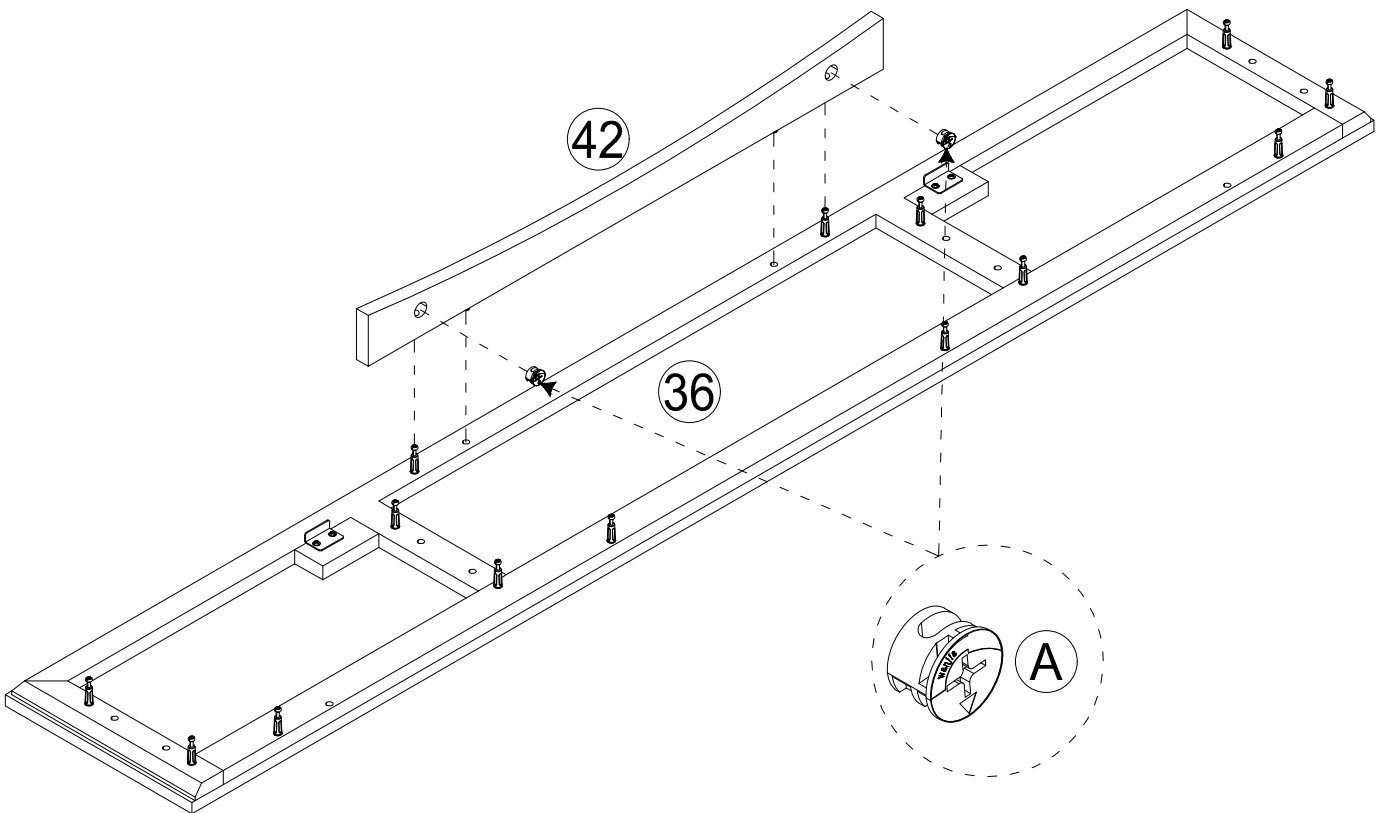
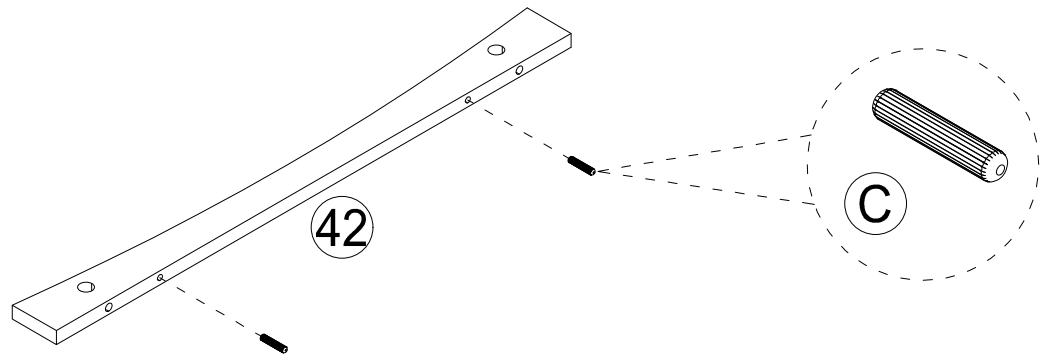
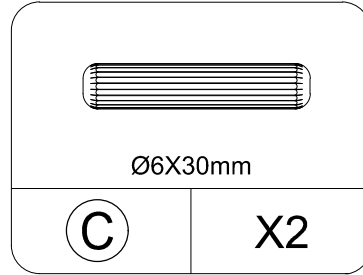
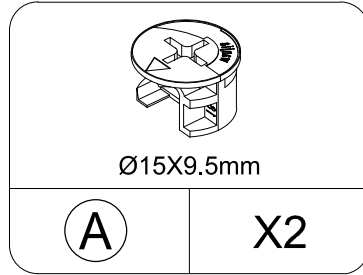
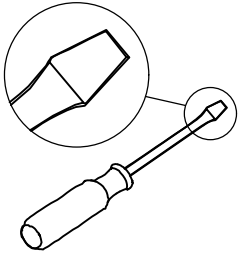

Insert the cam bolt into the hole first, then insert the cam lock and lock it.

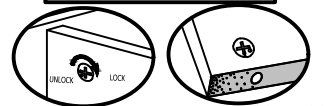

Proper orientation of CAM LOCK

Assembly Instructions

STEP 43

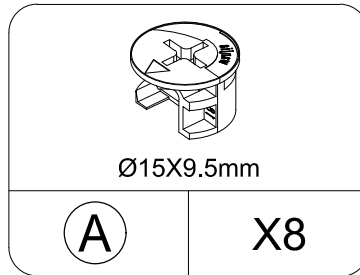
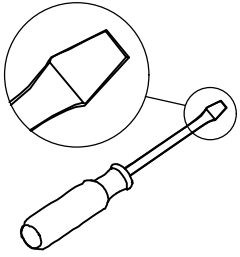

THIS STEP REQUIRES 2 PEOPLE

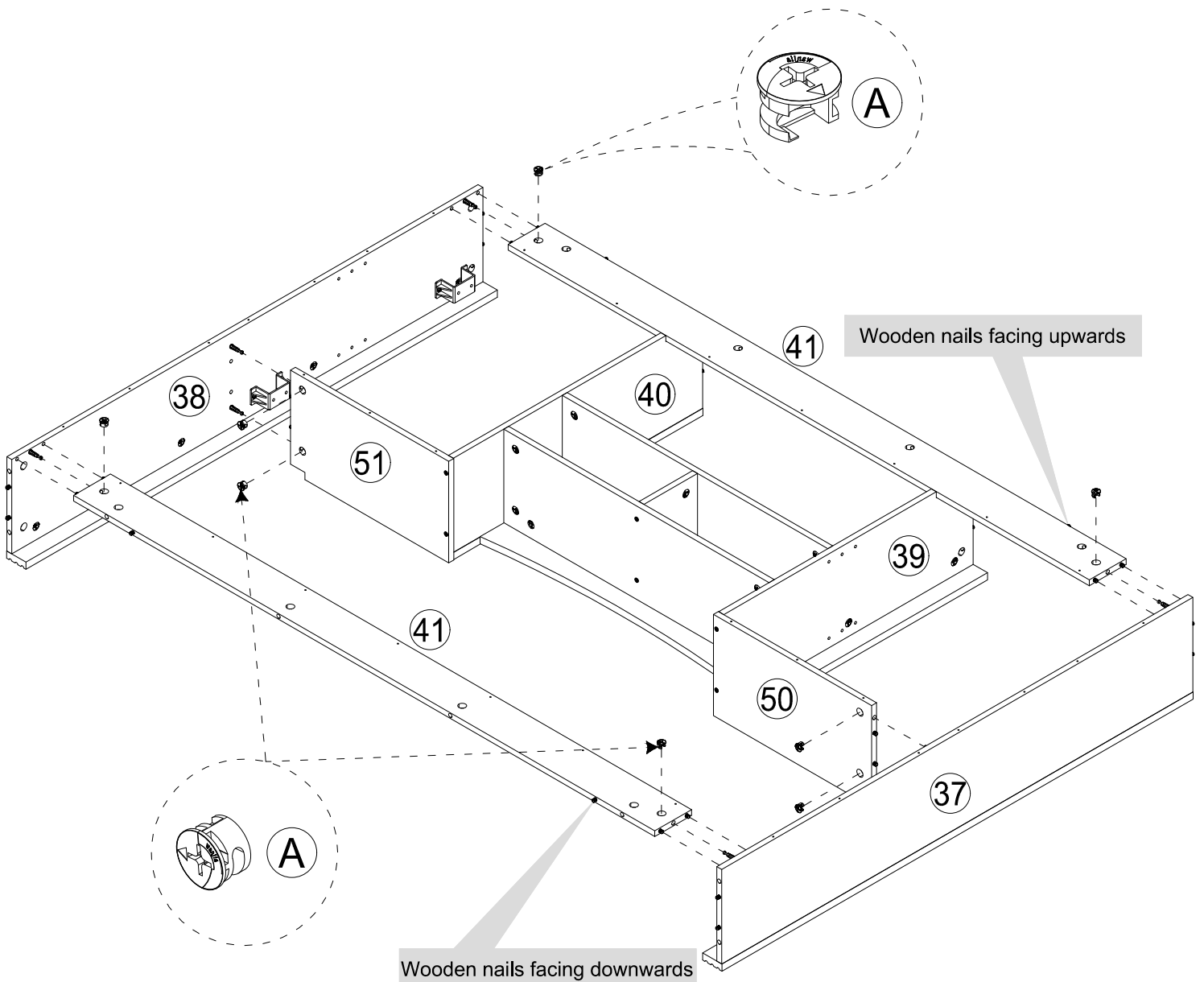

Insert the cam bolt into the hole first, then insert the cam lock and lock it.

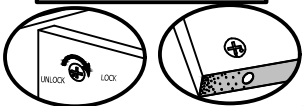

Proper orientation of CAM LOCK

Assembly Instructions

STEP 44

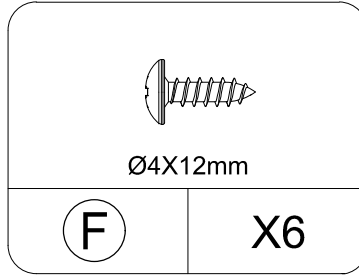
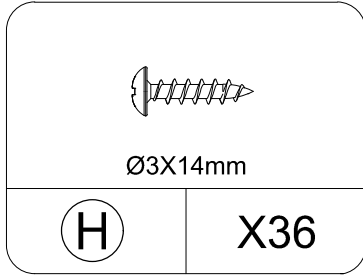
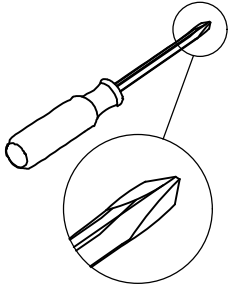

If you have an electric screwdriver tool at home, it will make installation faster

Note: Ensure the middle seal before tightening the screw (F)

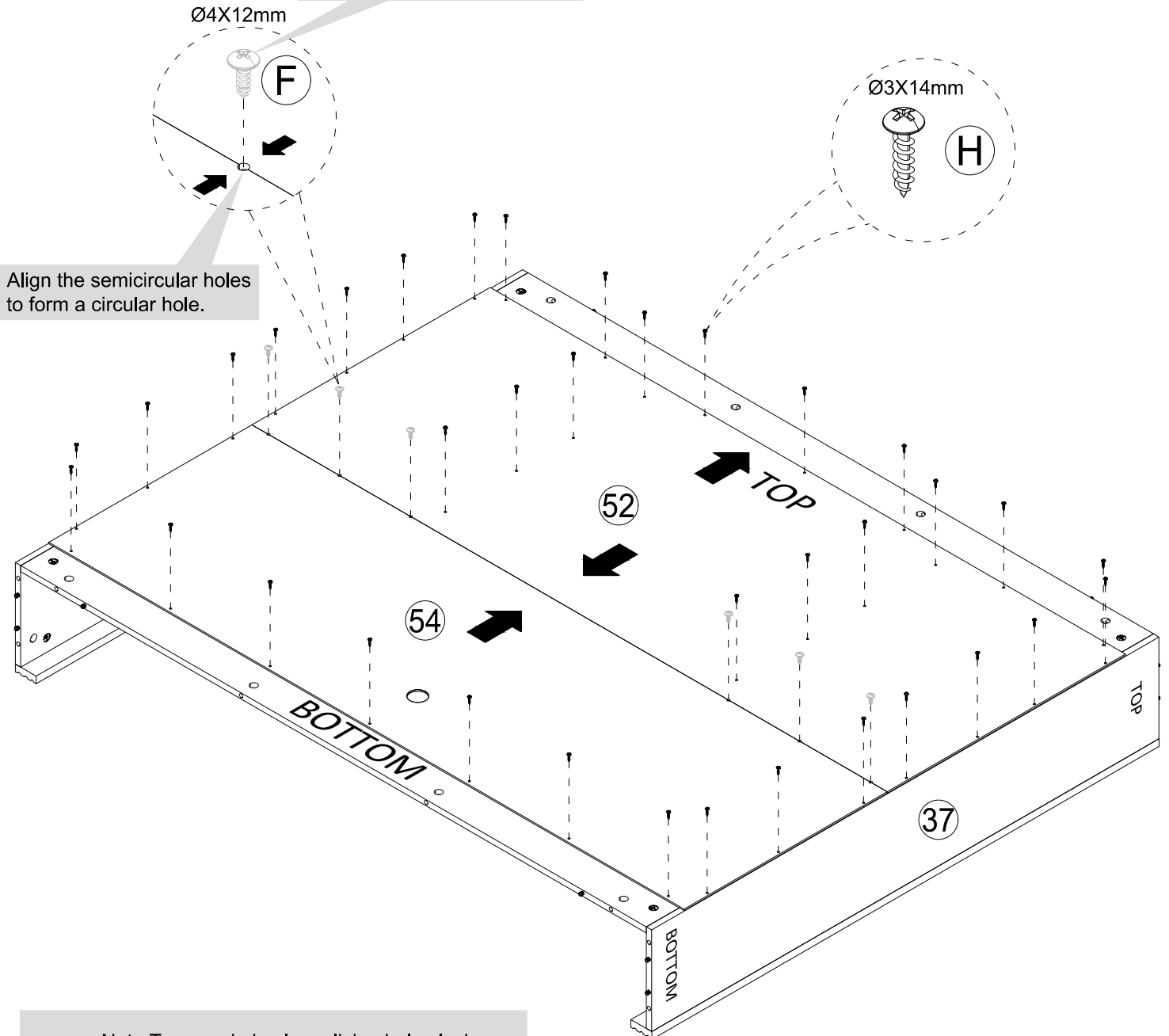

Note: Two semi-circular splicing holes lock with screws (F), and circular holes lock with screws (H)

Assembly Instructions

STEP 45

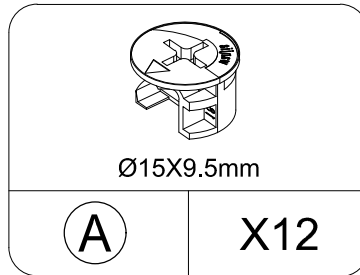
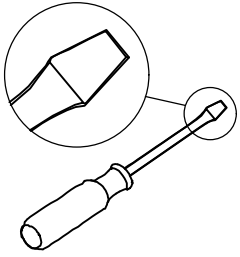

THIS STEP REQUIRES 2 PEOPLE

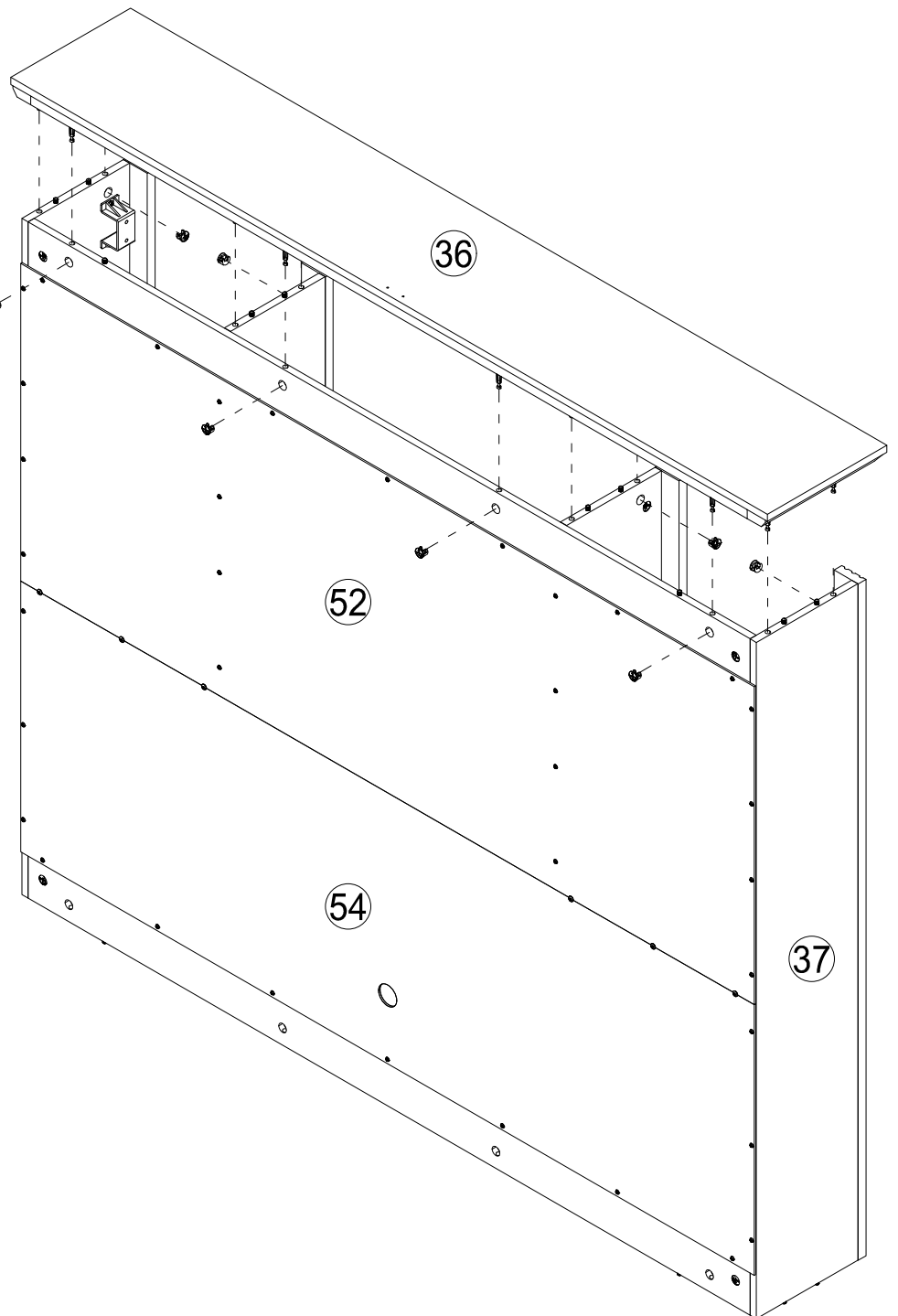
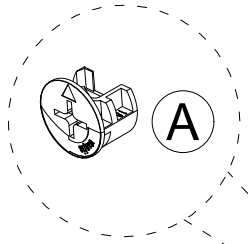

Insert the cam bolt into the hole first, then insert the cam lock and lock it.

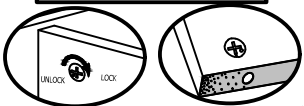

Assembly Instructions

STEP 46

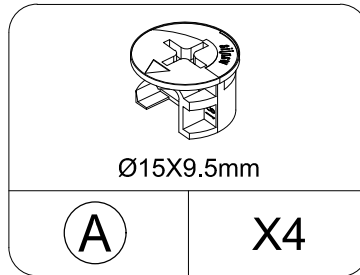
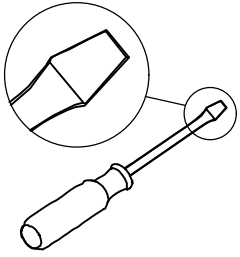

THIS STEP REQUIRES 2 PEOPLE

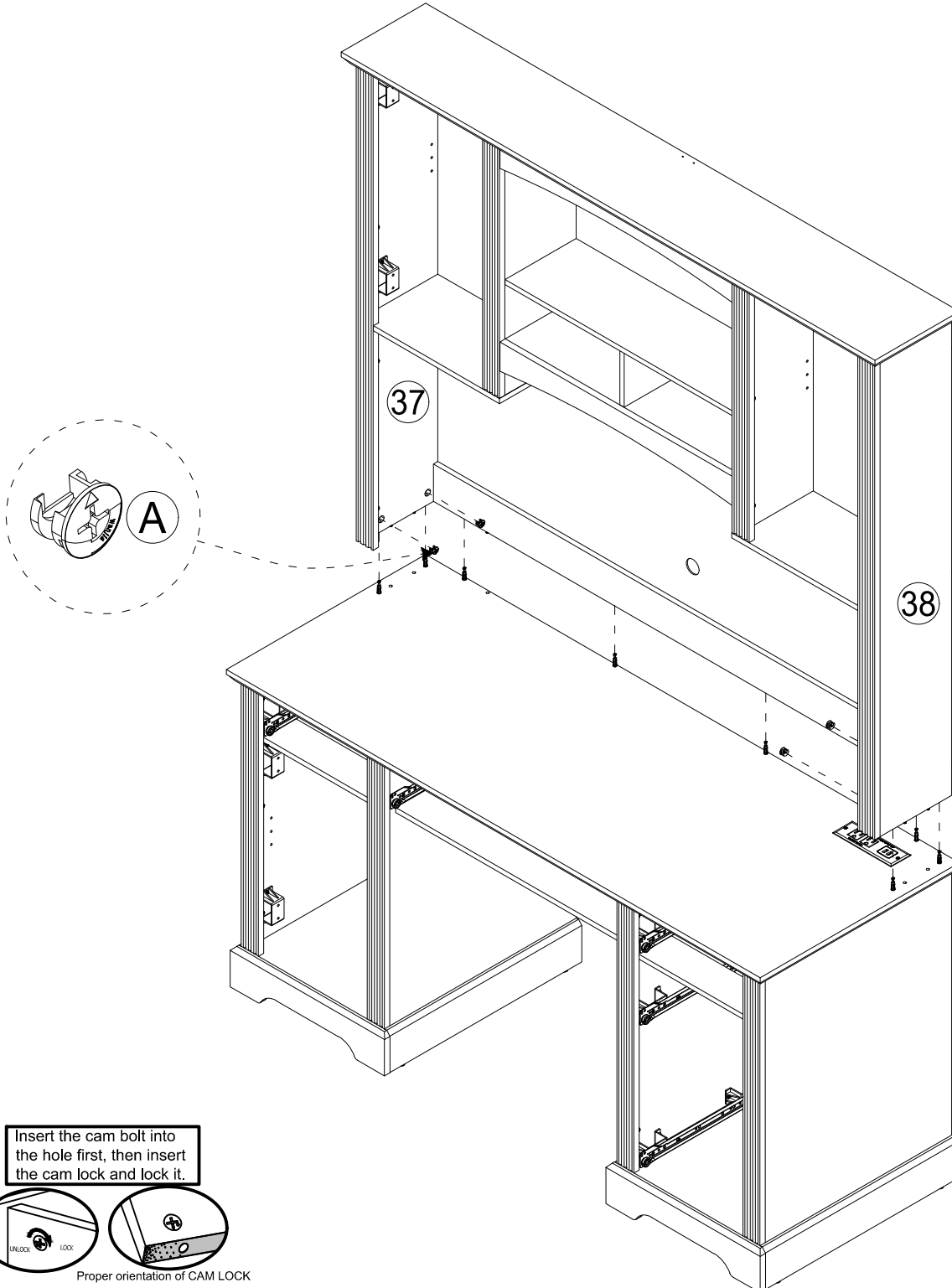

Assembly Instructions

STEP 47

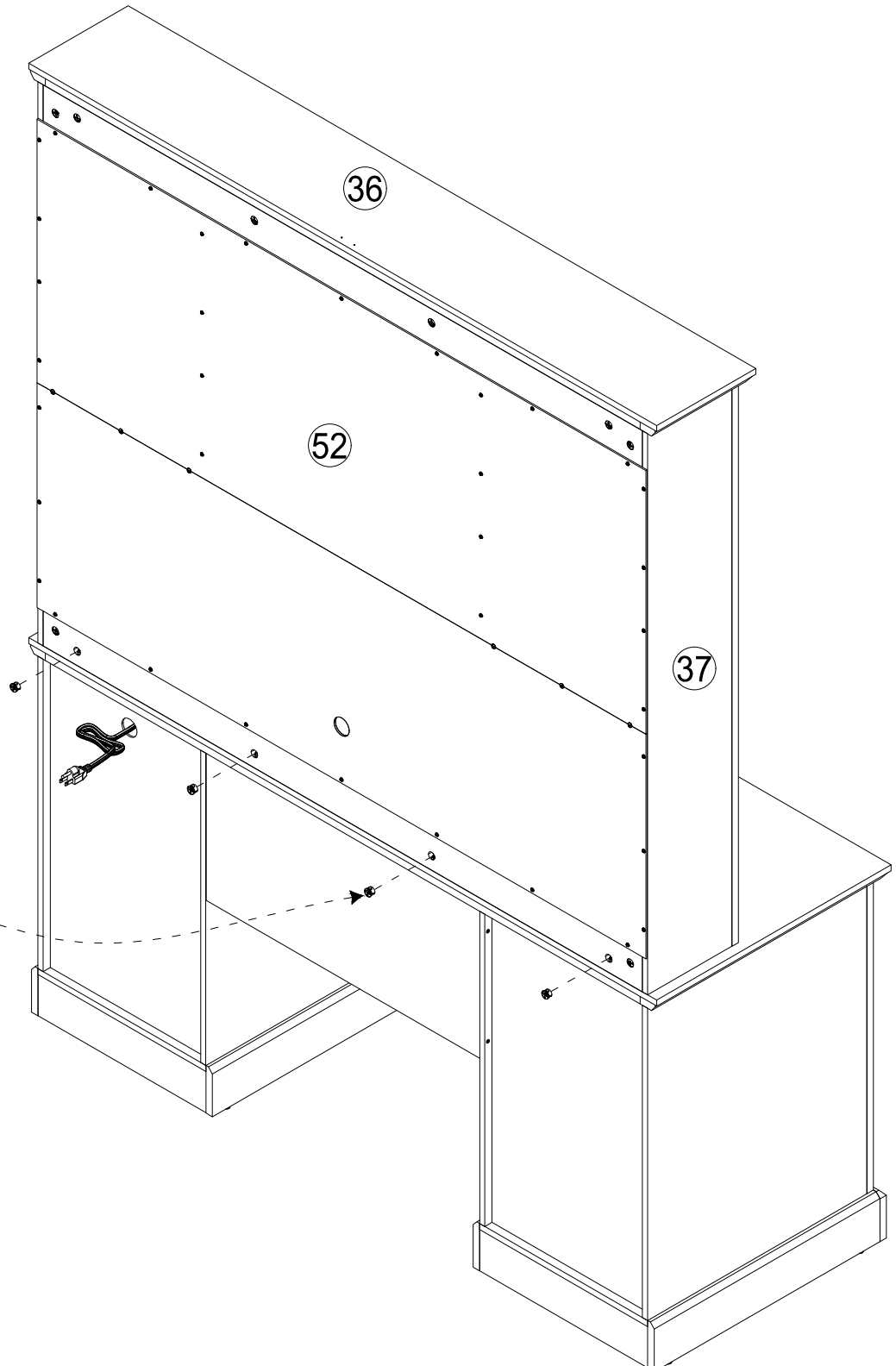
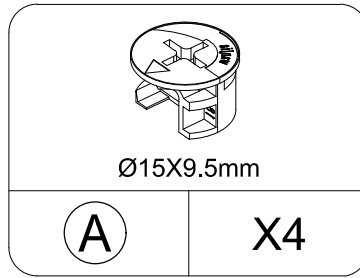
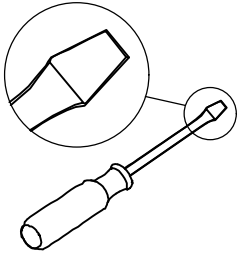

Insert the cam bolt into the hole first, then insert the cam lock and lock it.

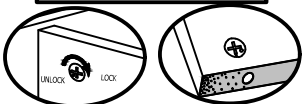

Proper orientation of CAM LOCK

Assembly Instructions

STEP 48

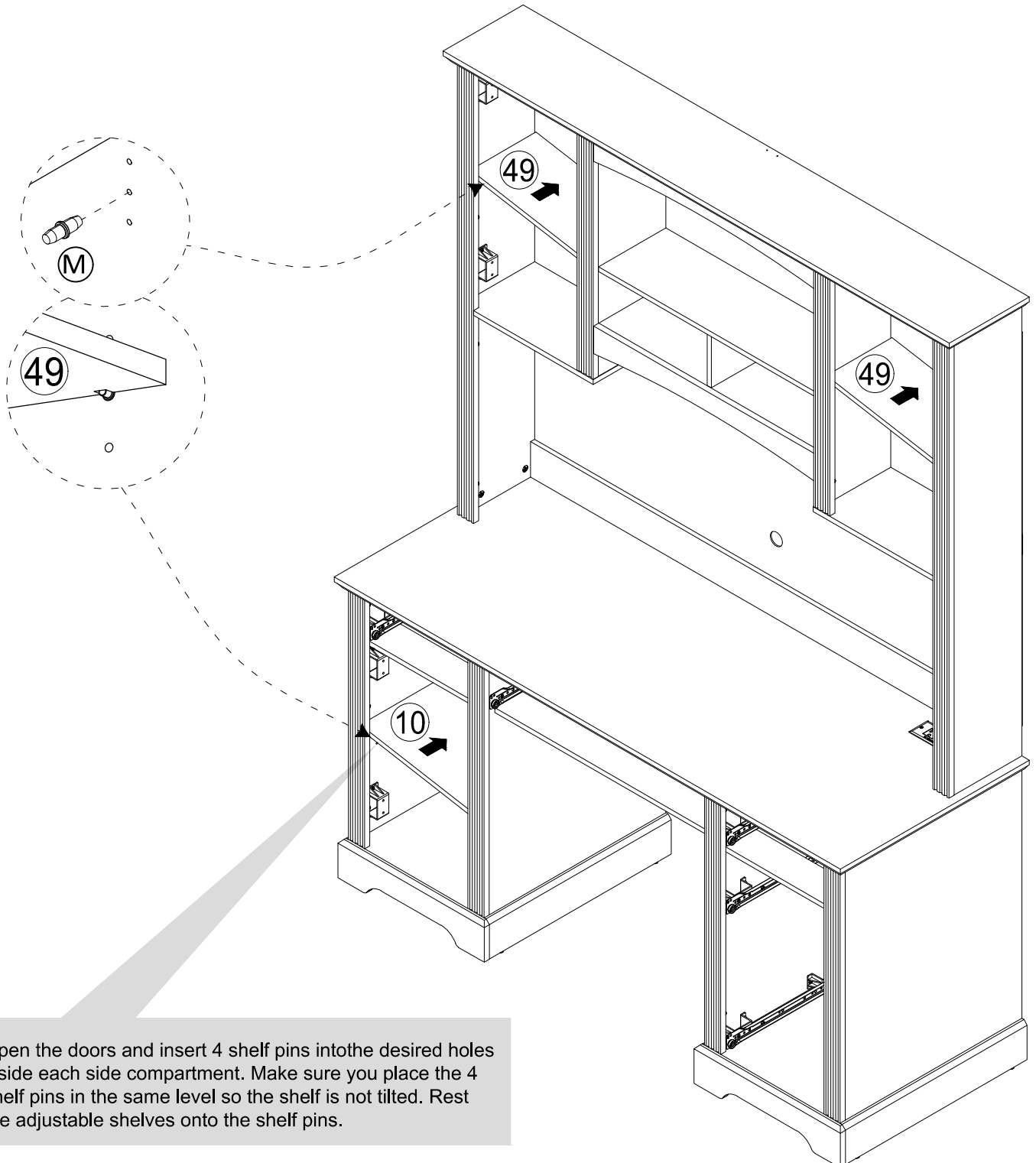
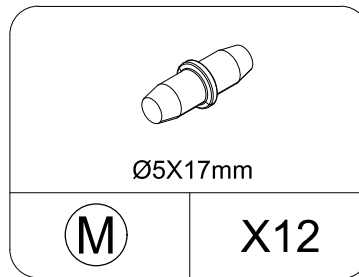

Open the doors and insert 4 shelf pins into the desired holes inside each side compartment. Make sure you place the 4 shelf pins in the same level so the shelf is not tilted. Rest the adjustable shelves onto the shelf pins.

Assembly Instructions

STEP 49

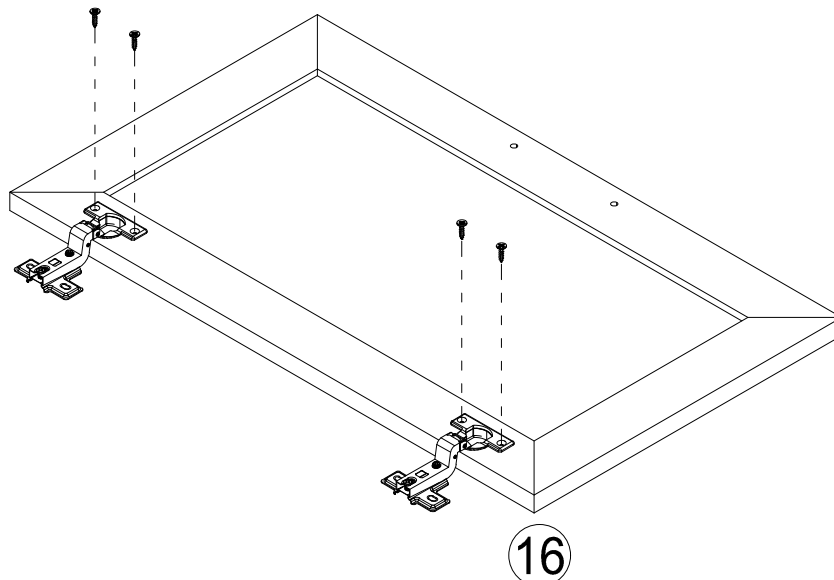
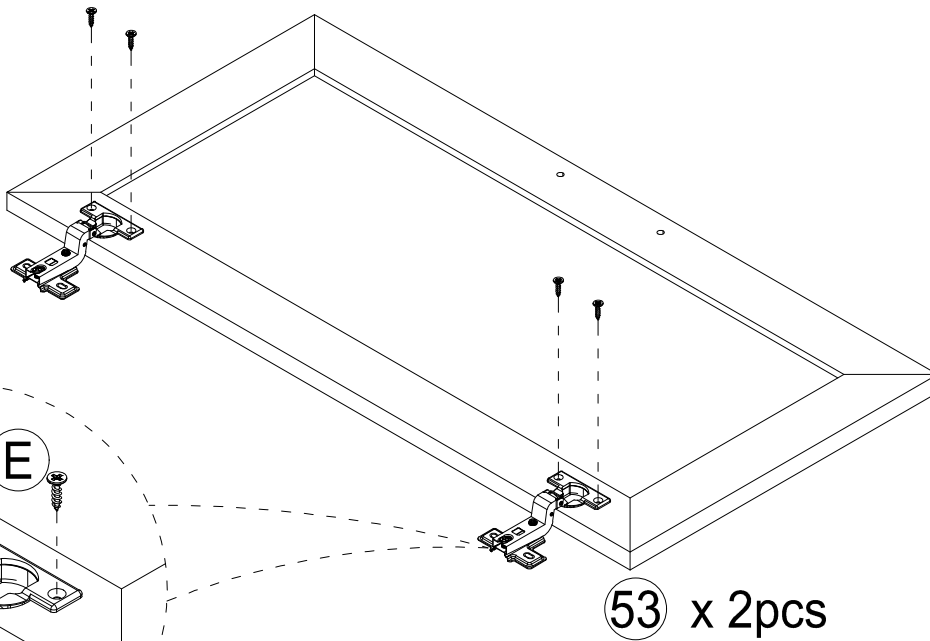
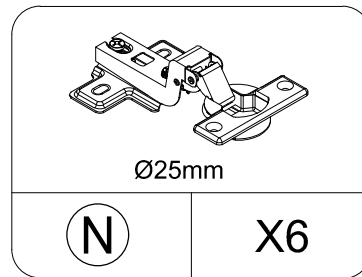
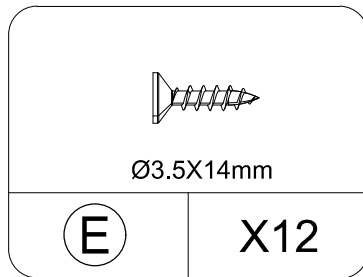
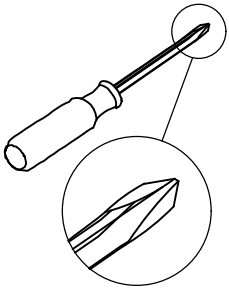

Assembly Instructions

STEP 50

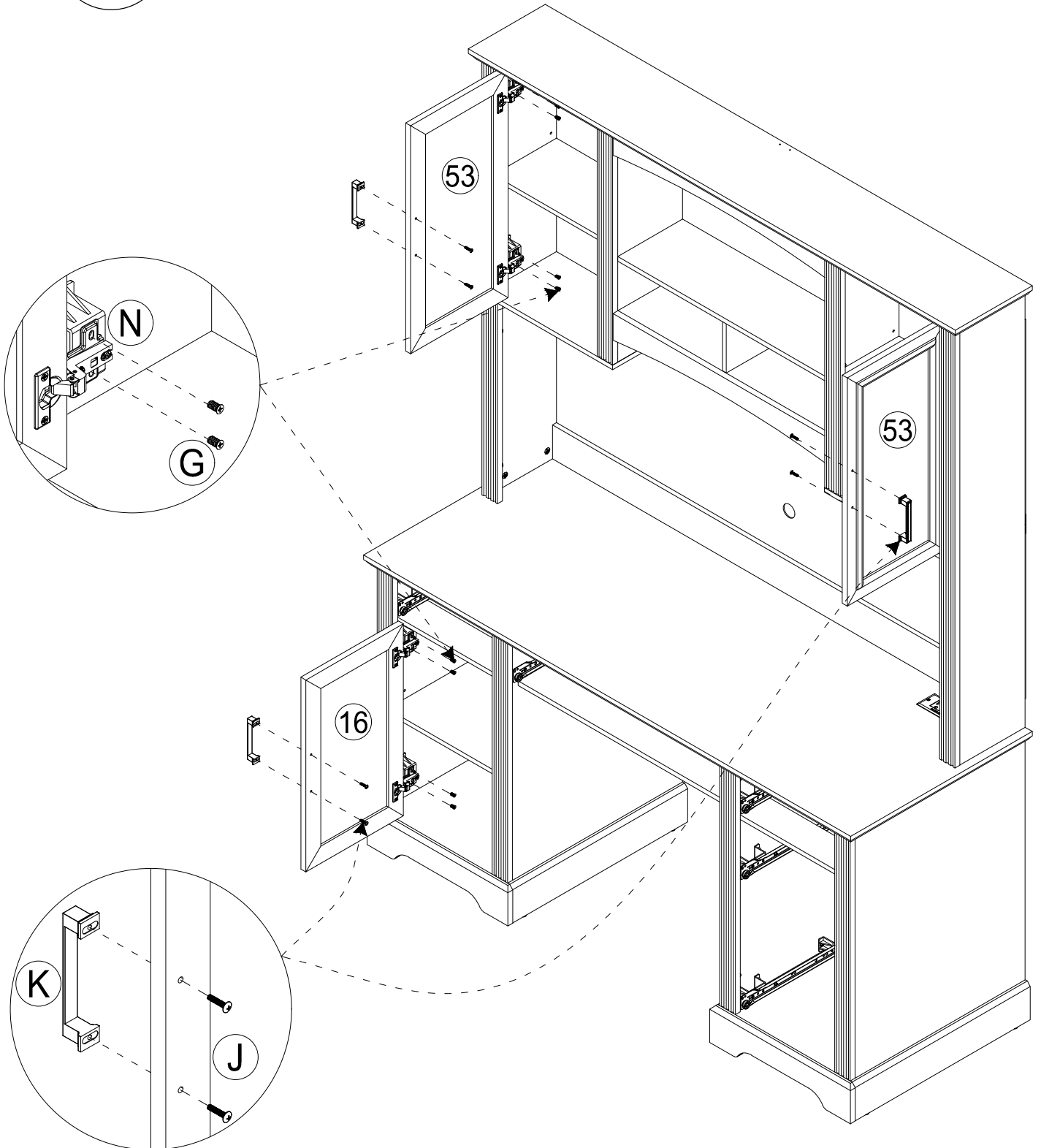
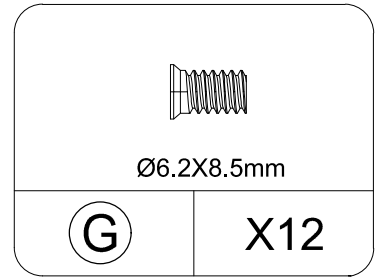
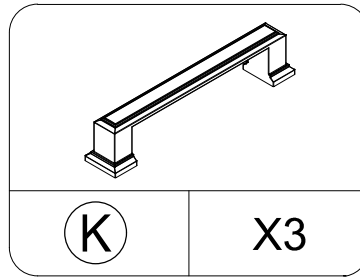
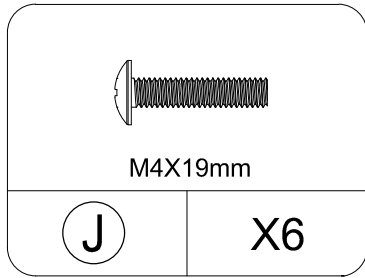
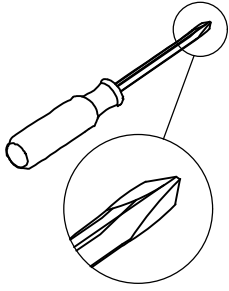

Assembly Instructions

STEP 51

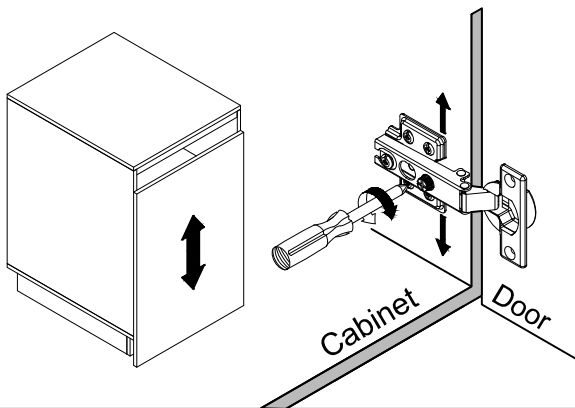
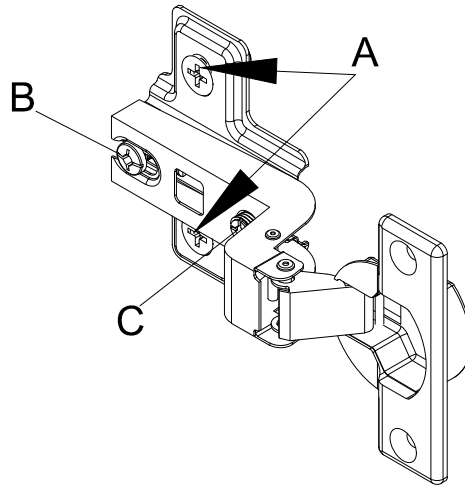

To adjust the vertical height.

Loosen the four screws "A" on both hinges. Two of them are usually in slotted holes which allows you to adjust up or down by a few mm. Then tighten back up.

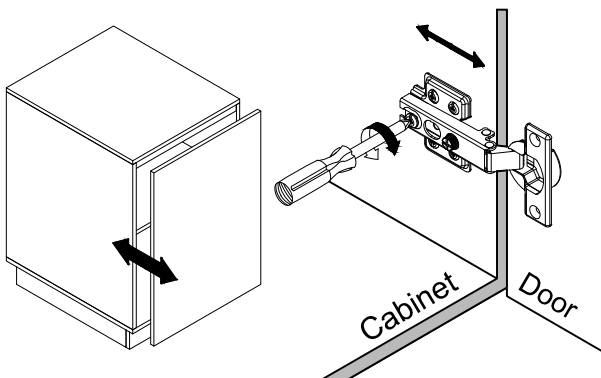

To adjust depth.

Loosen screw "B" and adjust door, if the door can not be adjusted, please loosen screw "C", then try again. Tighten screw "B" and "C".

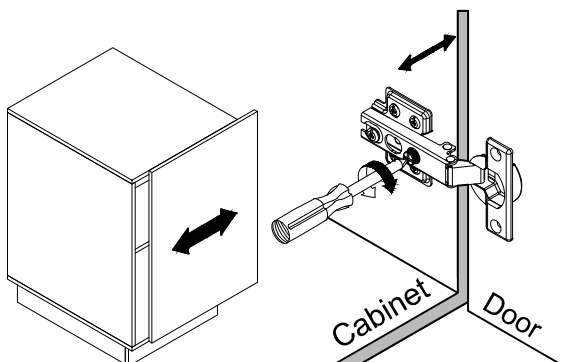

To adjust side ways.

Turning the screw "C" on BOTH hinges on each door.

Assembly Instructions

STEP 52

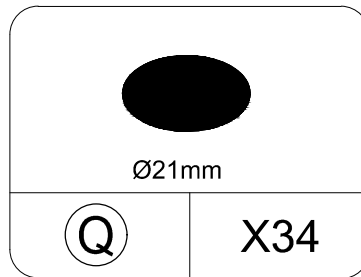

Stick the exposed holes of the cabinet body with hole stickers (Q)

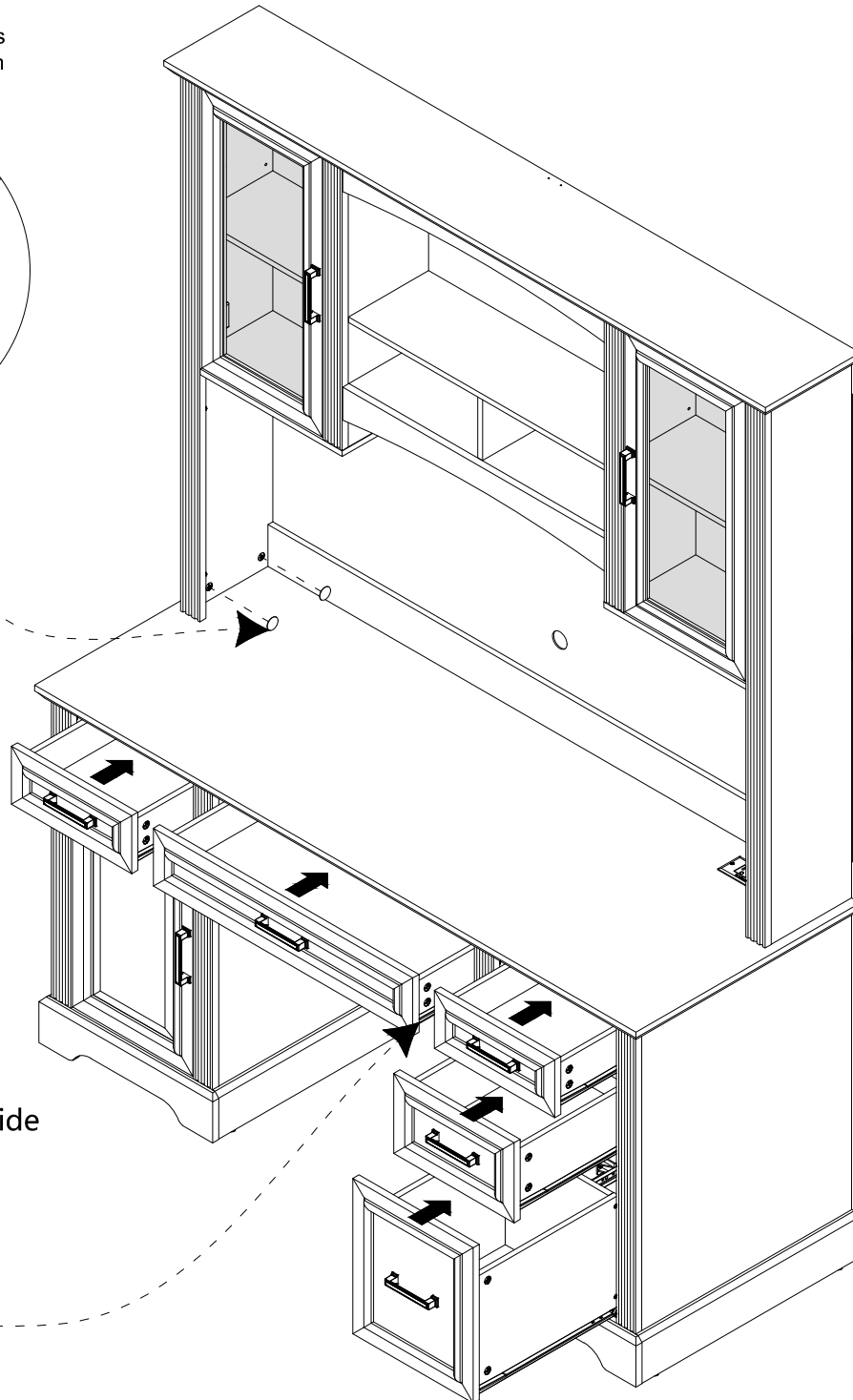
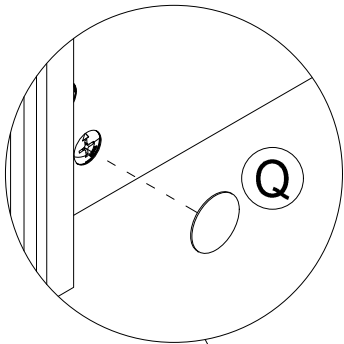

Cabinet Slide

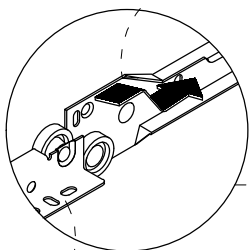

Drawer Slide

Assembly Instructions

STEP 53

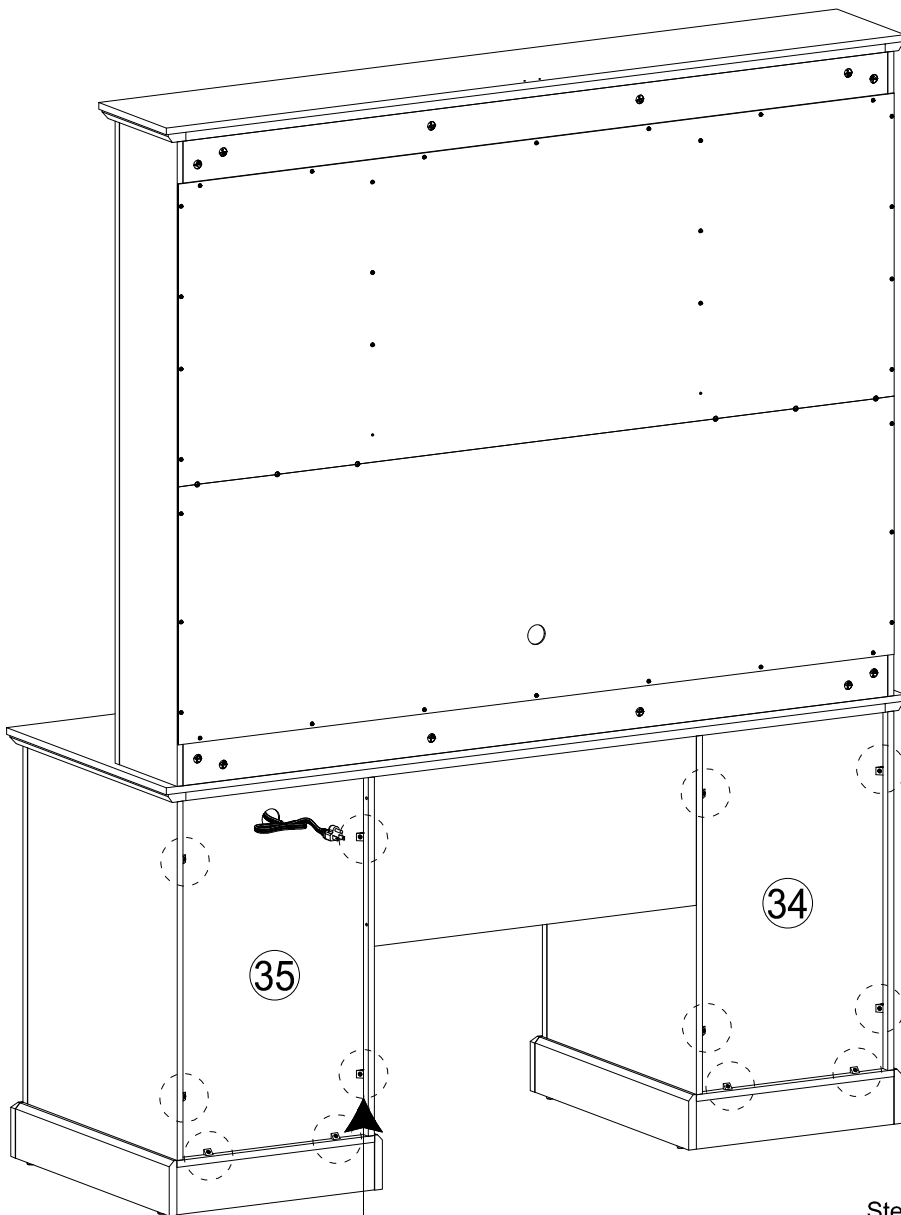
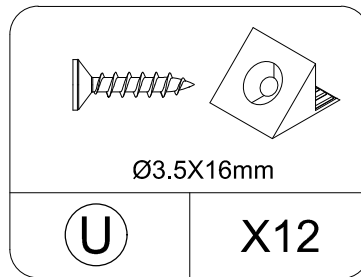

Step 1

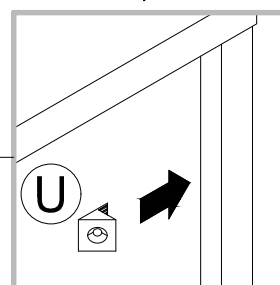

Step 2

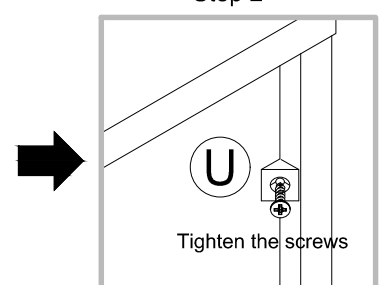

Assembly Instructions

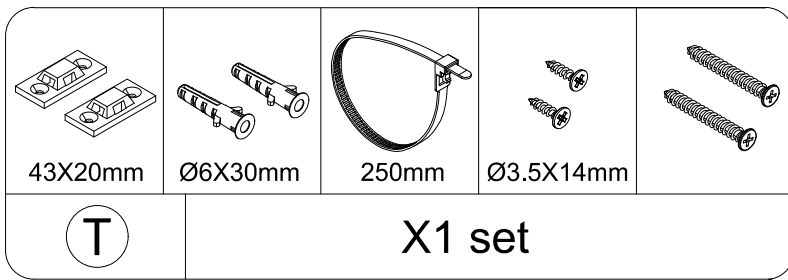

NOTE:The tipping restraint hardware included is for wooden stud wall construction. It must be attached to a wall stud. Depending upon your wall construction different anchor hardware maybe required. Please contact your local hardware store for assistance. Young children can be seriously injured by tipping furniture. You must install the tipping restraint hardware with the unit to prevent the unit from tipping, causing any accidents or damage. The tipping restraints are intended only as a deterrent and are not a substitute for proper adult supervision. The tipping restraints are not earthquake restraints. If you wish to add the extra security of earthquake restraints, they must be purchased and installed separately.

We have included a set of tipping restraint hardware for this unit. You must install this hardware to prevent accidents or injuries that can result from the unit falling. When properly installed, this restraint can provide protection against the unexpected tipping of the unit due to small tremors, bumps or climbing. We strongly recommend mounting this hardware to a wall stud and your unit.



Install the tipping restraint hardware

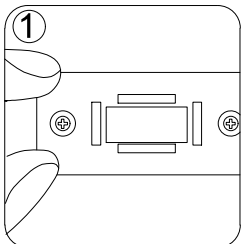

1. make mark on the wall

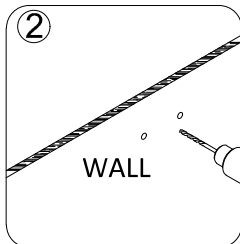

2. drill two Ø6 holes on the wall

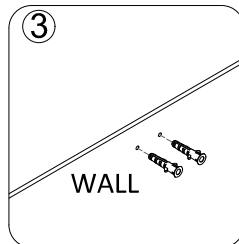

3. put two anchors in the holes

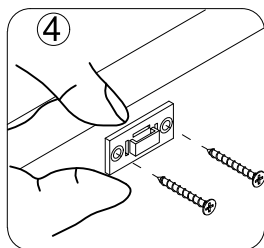

4. fix the device on the wall by the long screws

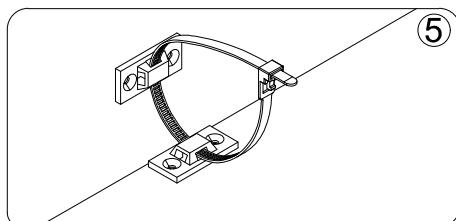

5. Push the cabinet close to the wall so that the two bases are close to each other, and then put on nylon tie to tighten it.

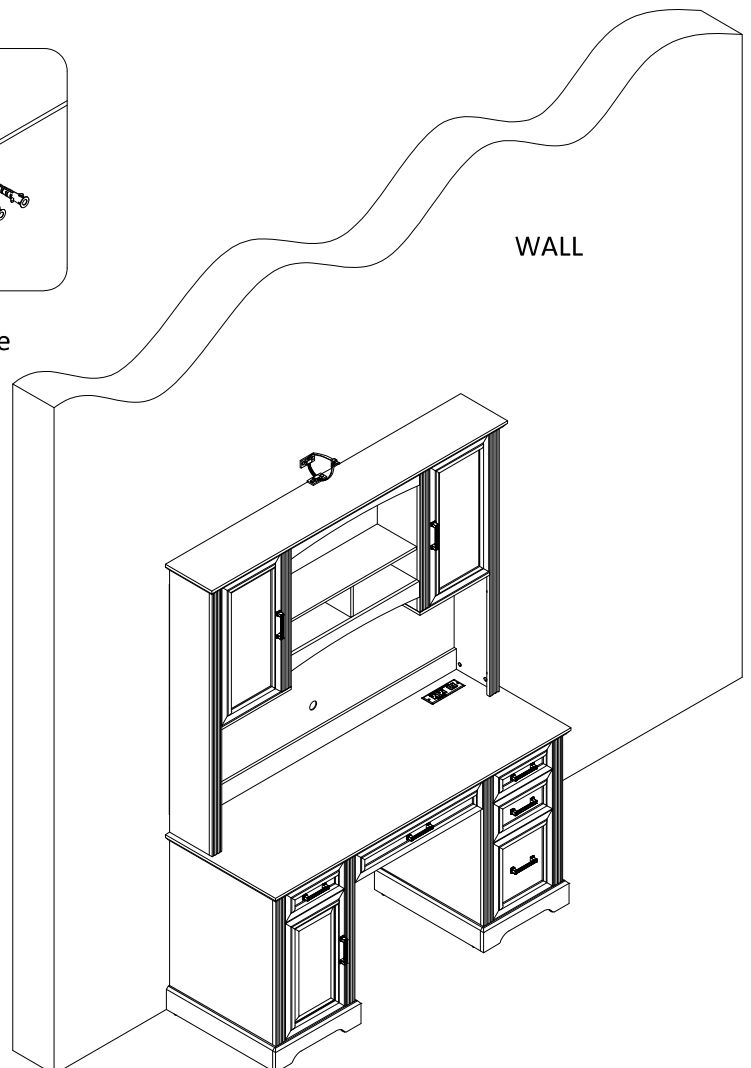

GENERAL GUIDELINES

- Please read the following instructions carefully and use the product accordingly.
- Please keep this instruction and hand it over when you transfer the product.
- This summary may not include every detail of all variations and considered steps.
- Please contact us when further information and help are needed.

NOTES

- The product is intended for normal use only. The seller does not assume any responsibility or liability with respect to any damage caused by incorrect assembly or improper use.
 - Keep away from exposure and heat sources. Place it in a dry area to avoid peeling or fading.
 - Please check if there is any welding spatter or debris when you receive the product.
 - If there are defective or missing parts after unpacking, please contact us immediately.
 - Use soft cloth and neutral detergent to wipe it clean, then wipe dry. Do not use an abrasive agent to wipe the product.
-
- During assembly, keep small parts out of the reach of children. It may be fatal if swallowed or inhaled.
 - To avoid potential danger of suffocation, keep all parts and packaging (films, plastic bags and foam, etc.) away from babies and children.
 - Keep away from sharp or corrosive items to avoid potential product damage or bodily injury.

- Bitte lesen Sie die folgende Anleitung aufmerksam durch und verwenden Sie das Produkt sachgemäß.
- Bewahren Sie diese Anleitung gut auf und händigen Sie sie bei Weitergabe des Produkts an Dritte ebenfalls mit aus.

Aus Gründen der Übersicht können nicht alle Details zu allen Varianten und denkbaren Montagen beschrieben werden. Wenn Sie weitere Informationen und Hilfe benötigen, kontaktieren Sie uns bitte.

HINWEISE

- Das Produkt ist nur für die Verwendung im Innenbereich vorgesehen. Montieren und verwenden Sie das Produkt nur wie in dieser Anleitung beschrieben. Eine andere Verwendung als beschrieben, oder eine Veränderung/ein Umbau des Produkts ist nicht erlaubt und kann zu Verletzungen und/oder Beschädigungen des Produkts führen. Der Händler übernimmt keine Haftung für Schäden, die durch unsachgemäßen Gebrauch oder falsche Montage entstanden sind.
- Nach Erhalt des Produkts überprüfen Sie es bitte, und stellen Sie sicher, dass kein Schweißschlacke oder Splitter vorhanden ist.
- Das Produkt darf nicht benutzt werden, wenn Teile beschädigt sind oder fehlen. Ansonsten könnten Schäden entstehen.
- Beim Zusammenbauen schrauben Sie bitte zuerst alle Schrauben nicht fest an, erst nach dem Aufbau ziehen Sie sie fest an.
- Bitte überprüfen Sie regelmäßig den Zustand der Schraubenbefestigung, da es das Risiko gibt, dass einige Schrauben beim Gebrauch gelöst werden. Stellen Sie sicher, dass alle Schrauben immer fest sind, um ein Umkippen beim Gebrauch zu vermeiden.

WARNHINWEIS

- Halten Sie Kinder während der Montage vom Arbeitsbereich fern. Zum Lieferumfang gehören eine Vielzahl von Schrauben und anderen Kleinteilen. Diese können beim Verschlucken oder Inhalieren lebensgefährlich sein.
- Lassen Sie keine Kinder auf den Artikel klettern, oder an dem Artikel spielen, um die Umkipppgefahr zu vermeiden.
- Zur Vermeidung der Erstickungsgefahr halten Sie die Verpackungsmaterialien wie Kunststoff-Verpackungstüten von Babys und Kindern fern.
- Vermeiden Sie generell jeden Kontakt mit spitzen Gegenständen und aggressiven Substanzen, um das Produkt vor Beschädigung zu schützen, und seine Sicherheit zu schützen.

FR

INTRODUCTION

- Lisez attentivement ces notes et utilisez votre produit conformément au présent mode d'emploi.
- Obéissez à ces instructions. Si vous voulez mettre ce produit à la disposition de tiers,
- veuillez joindre ce mode d'emploi.

Par souci de clarté, les détails concernant chaque variante ou montage envisageable ne peuvent être tous décrits. Si vous avez besoin de plus d'informations ou si vous rencontrez certains problèmes non traités de manière détaillée dans ces instructions, veuillez nous contacter.

NOTES

- Le produit doit être installé et utilisé conformément à ce mode d'emploi. Les utilisations qui ne correspondent pas à la description ci-dessus ou les modifications de l'article ne sont pas autorisées. Le vendeur n'est responsable d'aucun dommage résultant de l'installation incorrecte ou de l'utilisation non conforme
- Veuillez vérifier attentivement avant l'installation pour vous assurer qu'il n'y a pas de résidus de soudure ou de débris.
- Il est interdit d'utiliser des produits endommagés ou perdus, sinon, il y aura un risque de blessure.
- Lors de l'installation, veuillez positionner et ajuster correctement toutes les vis et les écrous, ensuite serrez progressivement l'ensemble des vis.
- Il est recommandé d'examiner périodiquement les vis qui pourraient se relâcher progressivement pendant l'utilisation, ce qui risque de provoquer des dommages causés par un renversement du produit. Veuillez donc à vous assurer que les vis sont bien serrées.
- Pour l'entretien quotidien, utilisez un chiffon doux et sec. Si nécessaire, vous pouvez utiliser un produit détergent à pH neutre. Ne jamais essuyer la surface avec un chiffon mouillé ou un matériau dur..

AVERTISSEMENTS

- Il est interdit aux enfants de participer à l'assemblage du produit car il comprend de nombreuses petites pièces et l'aspiration ou l'ingestion de ces pièces présente un risque mortel.
- Pour éviter le danger inattendu (par exemple, asphyxie), éloignez les enfants de tous les composants et emballages (films, sac en plastique, polystyrènes, etc.) .
- Eloignez les objets aigus ou corrosifs du produit afin d'éviter les dommages possibles.

IT

LINEE GUIDA GENERALI

- Leggere attentamente le seguenti istruzioni e usare il prodotto in modo opportuno.
- Conservare questo manuale e consegnarlo quando il prodotto cambia proprietario.
- Questo estratto potrebbe non includere ogni dettaglio di tutte le modifiche e le fasi considerate. Contattarci se hai bisogno di ulteriori informazioni e assistenza.

NOTE

- Il venditore non si assume alcuna responsabilità per quanto riguarda danni causati da montaggio scorretto o uso improprio.

- Controllare che non ci siano schizzi o residui di saldatura quando ricevi il prodotto.
- Nel caso in cui ci siano parti difettose o mancanti, contattare immediatamente l'assistenza clienti.
- Durante il processo di assemblaggio, serrare a metà le viti fino a quando il telaio non è completo, quindi serrarle completamente.
- Pulire con un panno morbido e un detergente neutrale e asciugare con un panno asciutto. Non utilizzare detersivi abrasivi per pulire il prodotto.

AVVERTENZE

- Durante l'assemblaggio, tenere le parti di piccole dimensioni lontano dai bambini. Potrebbero essere letali in caso di ingestione o inalazione.
- Tenere tutte le componenti e i materiali d'imballaggio (pellicole, sacchetti di plastica, polistirolo, ecc.) lontani dai bambini per prevenire il rischio di soffocamento.
- Tenere lontano da oggetti appuntiti o corrosivi per evitare potenziali danni al prodotto o lesioni.

SP

ACERCA DEL MANUAL

- Por favor, lea detenidamente las instrucciones y respete los debidos usos del producto.
- Por favor, conserve bien este manual y en caso de cesión, no olvide entregarlo junto con el producto.
- No es posible que se presenten todos los detalles y pasos de montaje en las instrucciones. Si necesita ayuda o información adicional, póngase en contacto con nosotros.

NOTAS

- Ha de montarse y utilizarse el producto paso a paso siguiendo estrictamente las instrucciones. De lo contrario, el vendedor no asumirá ninguna responsabilidad por los daños y lesiones causados por el montaje y los usos inadecuados.
- Después de recibir el producto, por favor compruebe atentamente para asegurar que no haya desechos de soldaduras ni pedacitos.
- Si hay las piezas perdidas o dañadas, no utilice el producto, de lo contrario, existirá el peligro de lesiones.
- No apriete totalmente ningún tornillo durante el montaje, una vez terminado el montaje, apriete completamente todos los tornillos.
- Inspeccione regularmente los tornillos. Durante el uso, los tornillos se podrán aflojar, causará daños al producto, por eso asegure que todos los tornillos estén bien apretados.

ADVERTENCIAS

- Debido a que existen múltiples tornillos y otras piezas pequeñas, no permita que se acerquen los niños por el riesgo de asfixia producida por tragar alguna pieza.
- Guarde el embalaje fuera del alcance de los niños para evitar el peligro de asfixia.
- No deje que el producto conecte con los objetos puntiagudos ni los productos químicos para evitar causar daños o lesiones.