

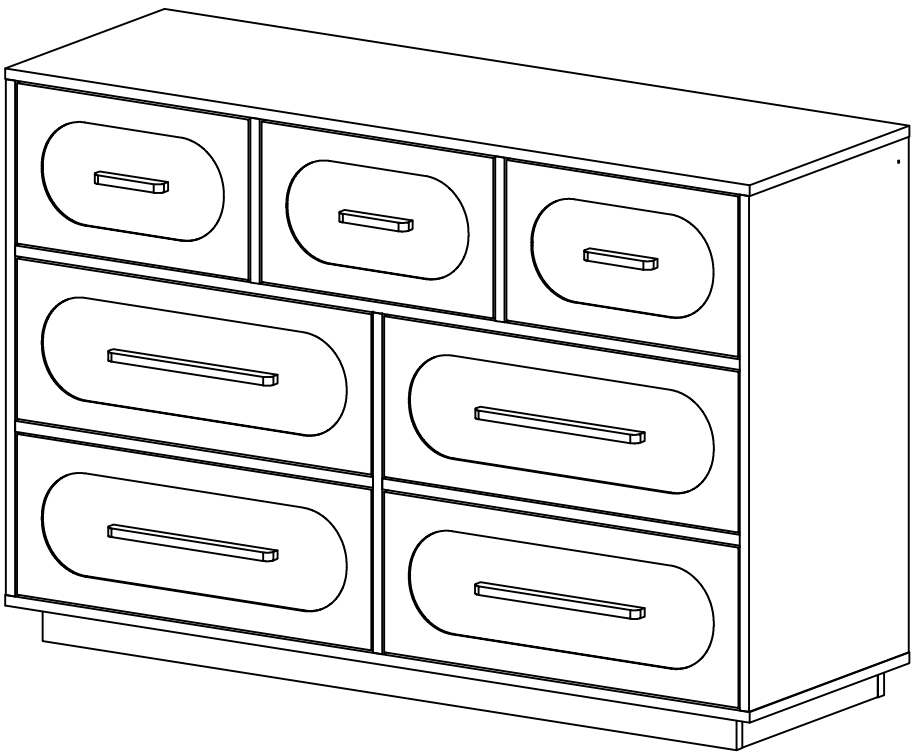

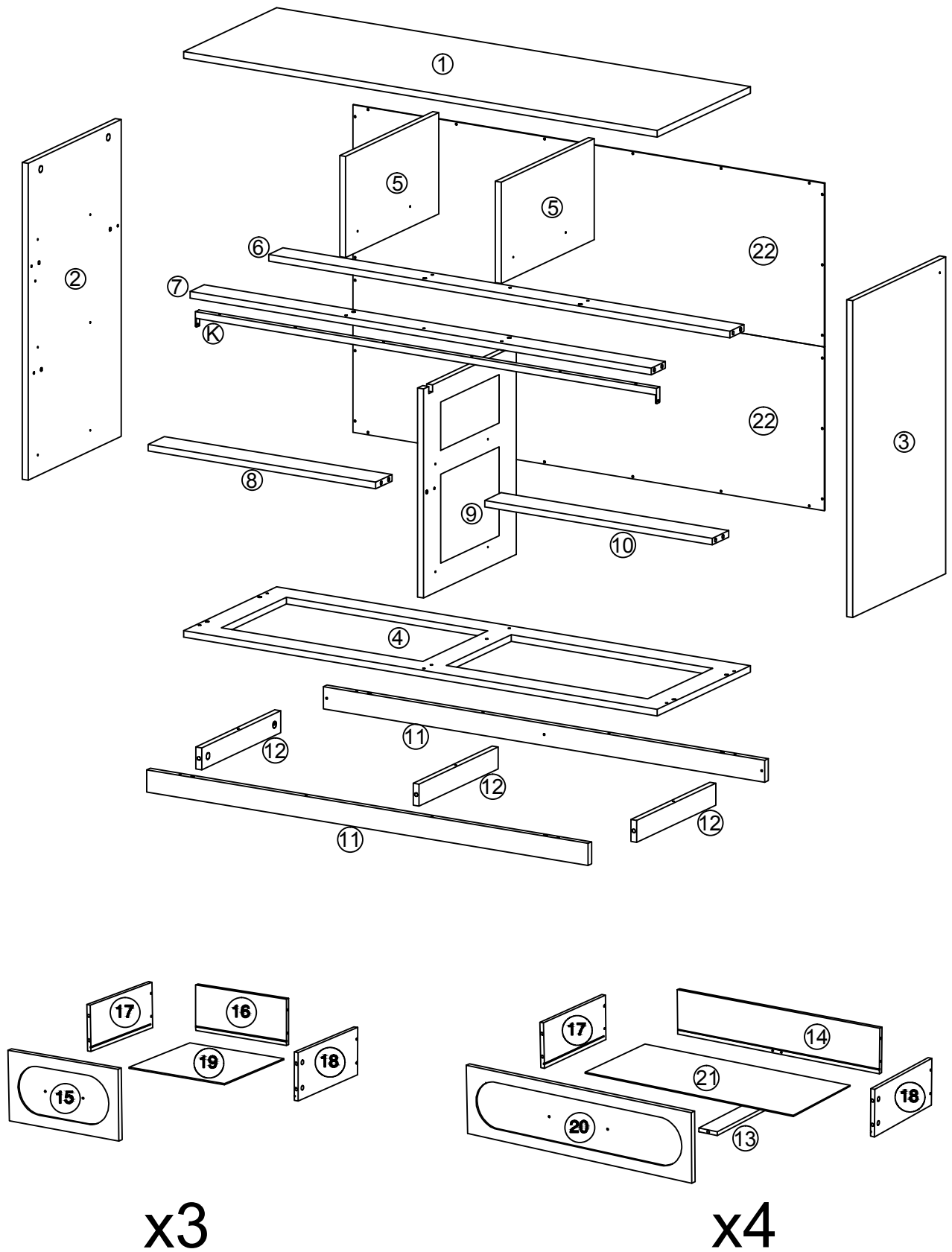



# Multifunctional storage Assembly Instructions



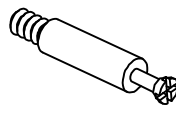

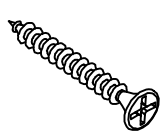
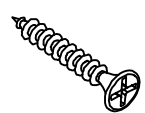

# Parts List

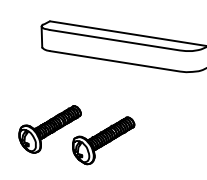
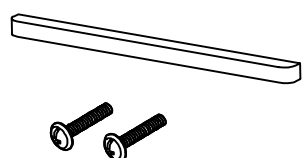
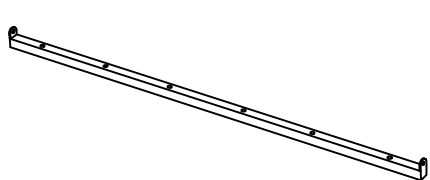
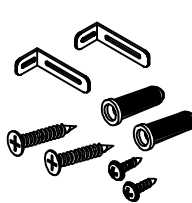
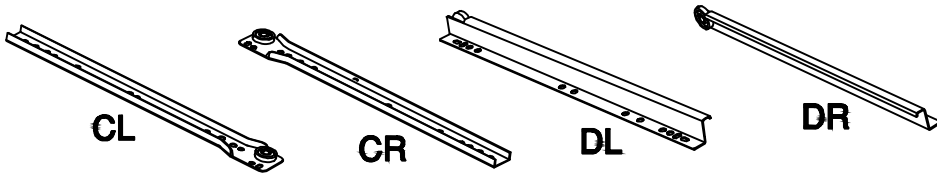
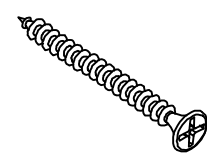
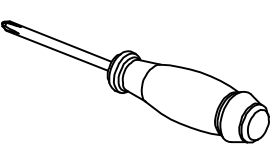



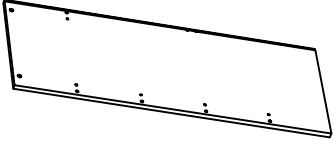
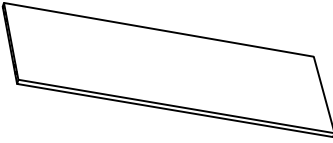
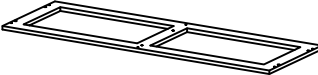
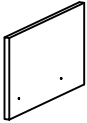

# Hardware

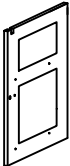

<p><b>A</b></p>  <p>M6 x 35mm    54+5PCS</p>	<p><b>B</b></p>  <p>Ø15 x 9mm    54+5PCS</p>	<p><b>C</b></p>  <p>Ø8 x 30mm    32+3PCS</p>	<p><b>D</b></p>  <p>Ø4 x 35mm    11+2PCS</p>
<p><b>E</b></p>  <p>Ø4 x 30mm    36+3PCS</p>	<p><b>F</b></p>  <p>Ø3.5 x 12mm    84+6PCS</p>	<p><b>G</b></p>  <p>Ø3.5 x 12mm    26+2PCS</p>	<p><b>H</b></p>  <p>Ø3.5 x 25mm    6+1PCS</p>
<p><b>I</b></p>  <p>3SETS</p>	<p><b>J</b></p>  <p>4SETS</p>	<p><b>K</b></p>  <p>1PC</p>	
<p><b>L</b></p>  <p>SAFETY STRAP KIT    1SET</p>	<p><b>M</b></p>  <p>CL    CR    DL    DR</p> <p>L300mm</p> <p>7 SETS</p>		
<p><b>N</b></p>  <p>Ø4 x 45mm    12+2PCS</p>	<p><b>O</b></p>  <p>1PC</p>		

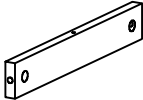
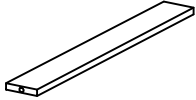
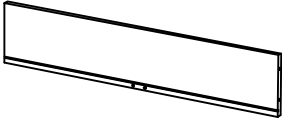
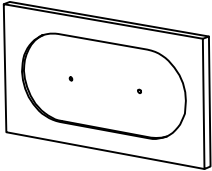
## ASSEMBLY MATERIAL

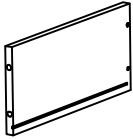
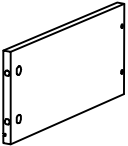
Item no.	Reference Image	QTY.
①		1
②		1
③		1
④		1
⑤		2
⑥		1
⑦		1
⑧		1
⑨		1

Item no.	Reference Image	QTY.
⑩		1
⑪		2
⑫		3
⑬		4
⑭		4
⑮		3
⑯		3
⑰		7
⑱		7

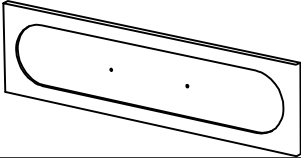
## ASSEMBLY MATERIAL

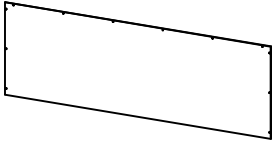
Item no.	Reference Image	QTY.
19		3
20		4
21		4
22		2

## How to use the cam lock system

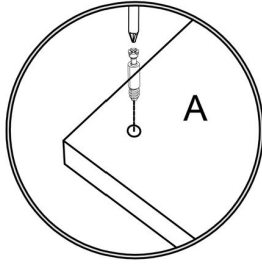

1. Screw cam bolt into panel

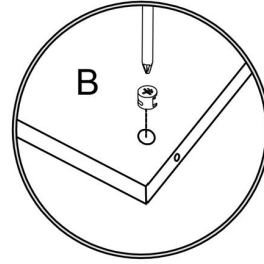

2. Push cam into panel - arrow feature on cam top points to panel edge

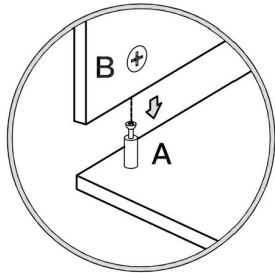

3. Align cam bolt(s) with cam(s) and insert all the way into cross-bored hole(s)

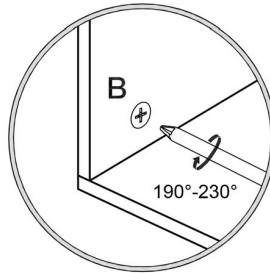

4. Rotate cam(s) clockwise 190°-230° to lock panels together

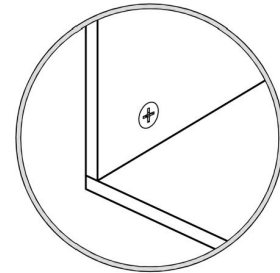

5. Panels should be tight against each other and connection should be rigid

Insert the wood dowel [C] at least half way by tapping lightly with a rubber mallet, IF NECESSARY.

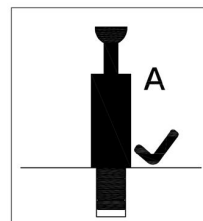
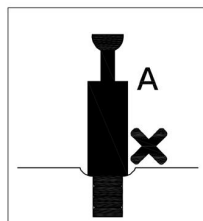
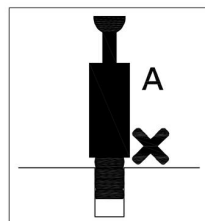
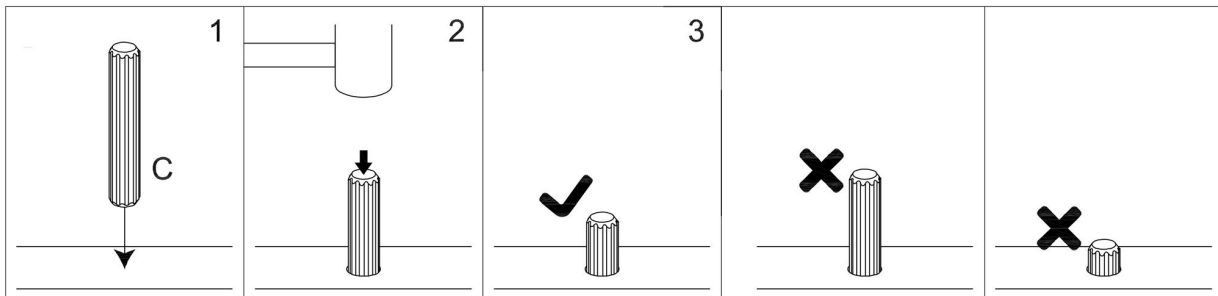

### **⚠ WARNING**

- Unit must be placed on a level surface or leveled with included hardware (when applicable).
- Do not sit or stand on or allow children to climb, sit or stand on the assembled product.
- For safety reasons, it is imperative that this unit be mounted to the wall.
- Do not use without installing the tip restraint.
- Unit can tip over causing severe injury or death.
- Do not exceed the recommended weight limits.
- Evenly distribute the weight on each level and always keep the heavier loads on the bottom.
- Before cutting, drilling or hammering into any wall or floor surface, verify the location of electrical, plumbing and gas lines. Cutting may cause serious injury.

# Step 1

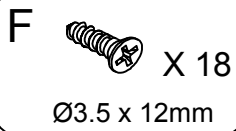

First secure the two screws with pre-drilled holes to ensure the rail is properly positioned.  
Then, install the first reinforcement screw (which has no pre drilled hole) to enhance overall stability.

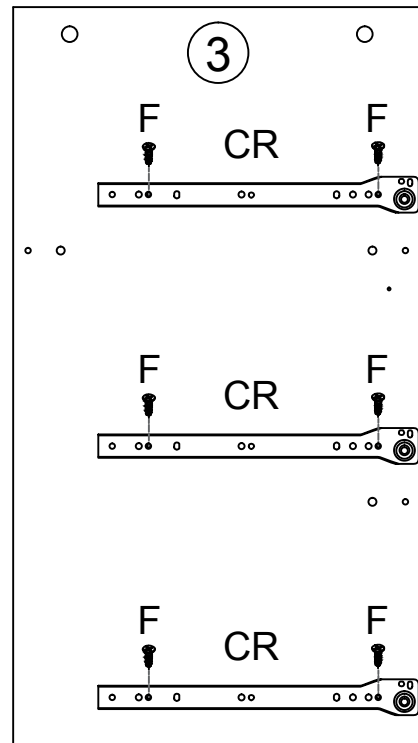
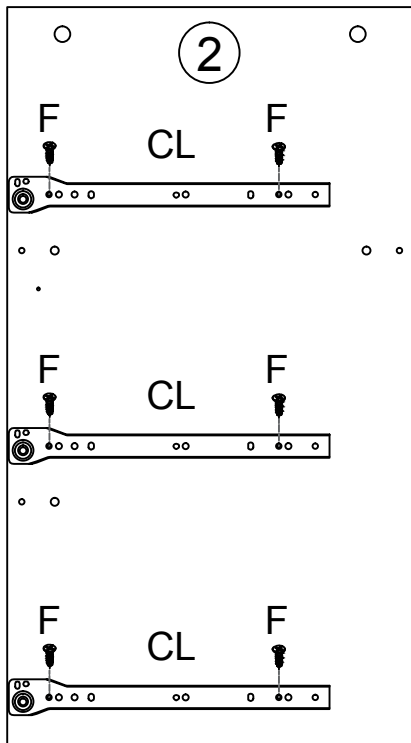
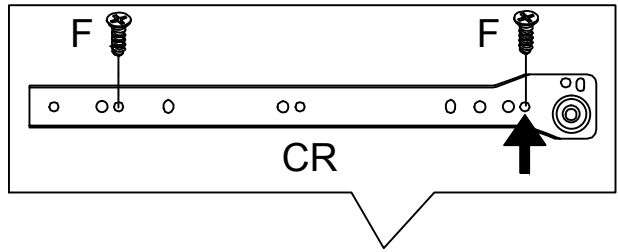
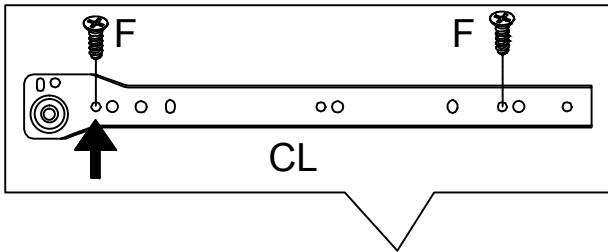

Step 2

F  X 12  
Ø3.5 x 12mm

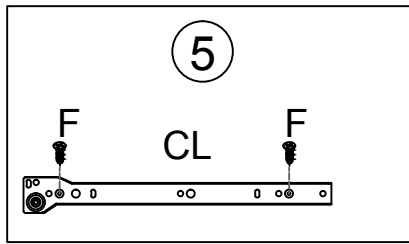
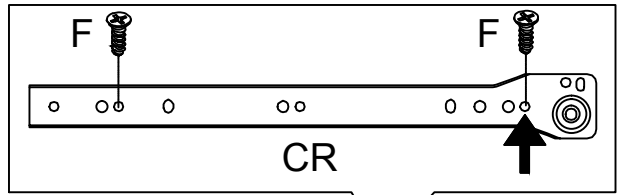

x2

180°

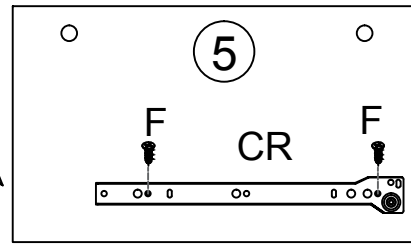

x2

Step 3

F  X 12  
Ø3.5 x 12mm

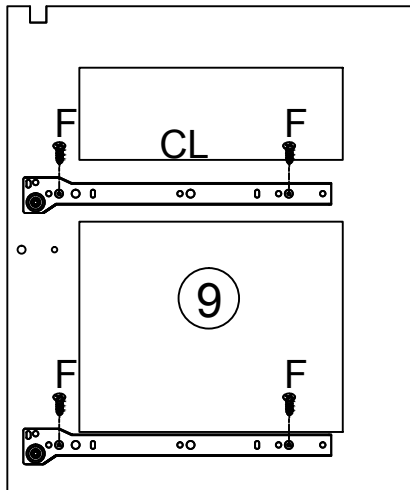
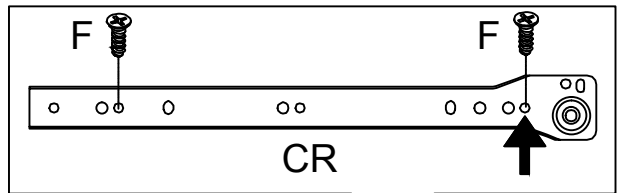
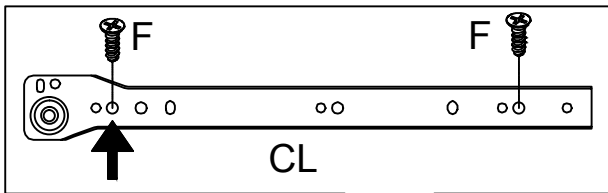

180°

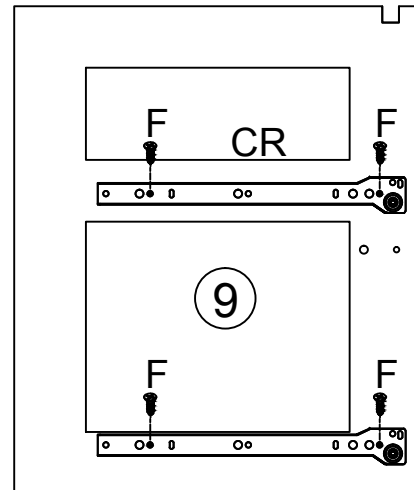

Step 4

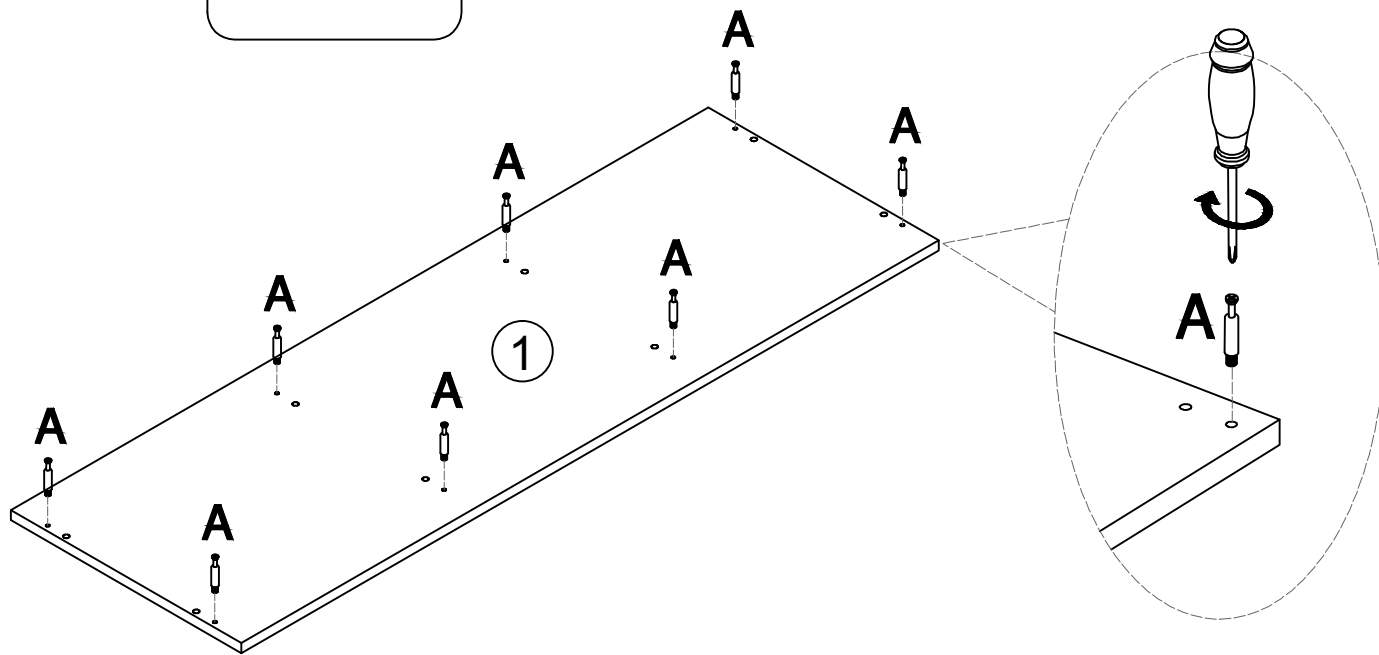
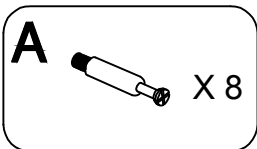

Step 5

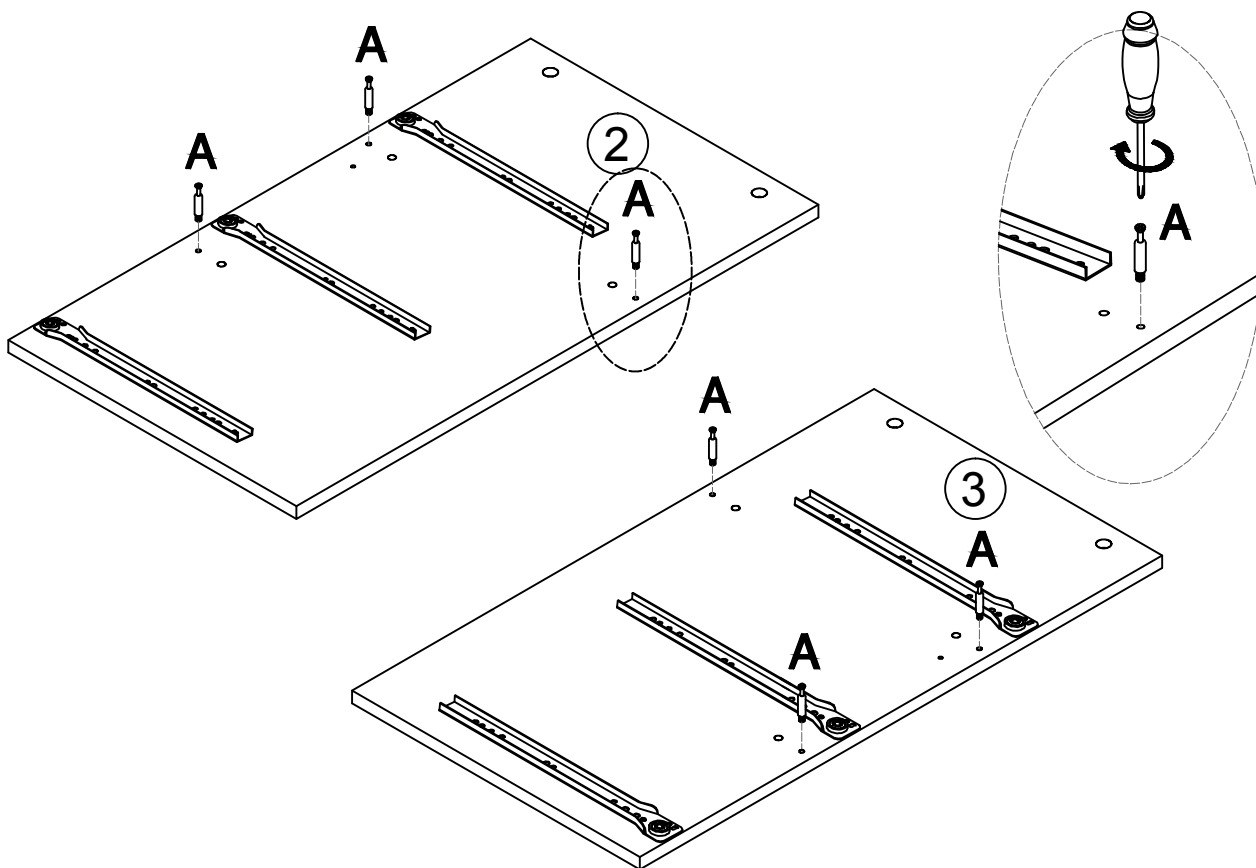
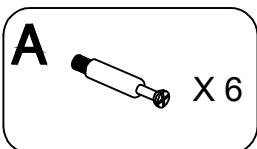

Step 6

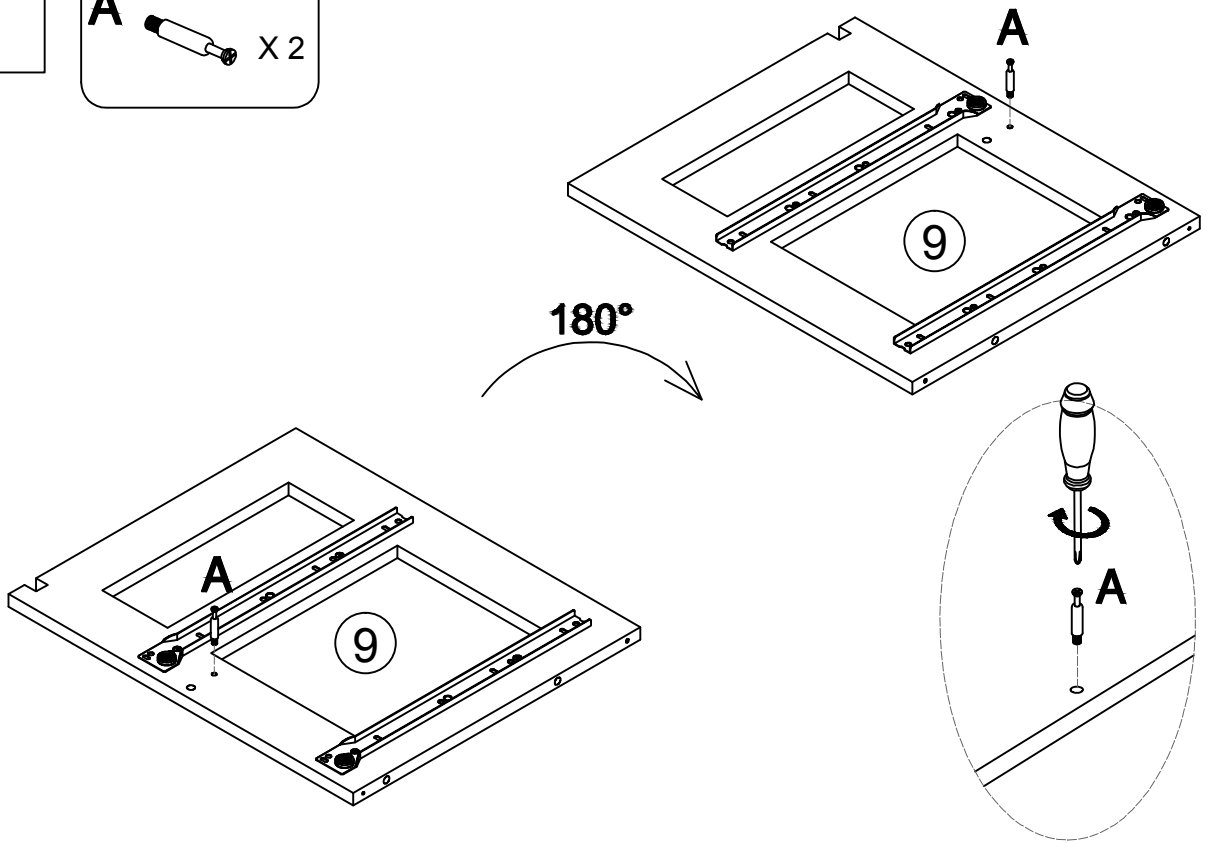
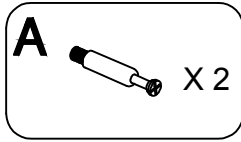

Step 7

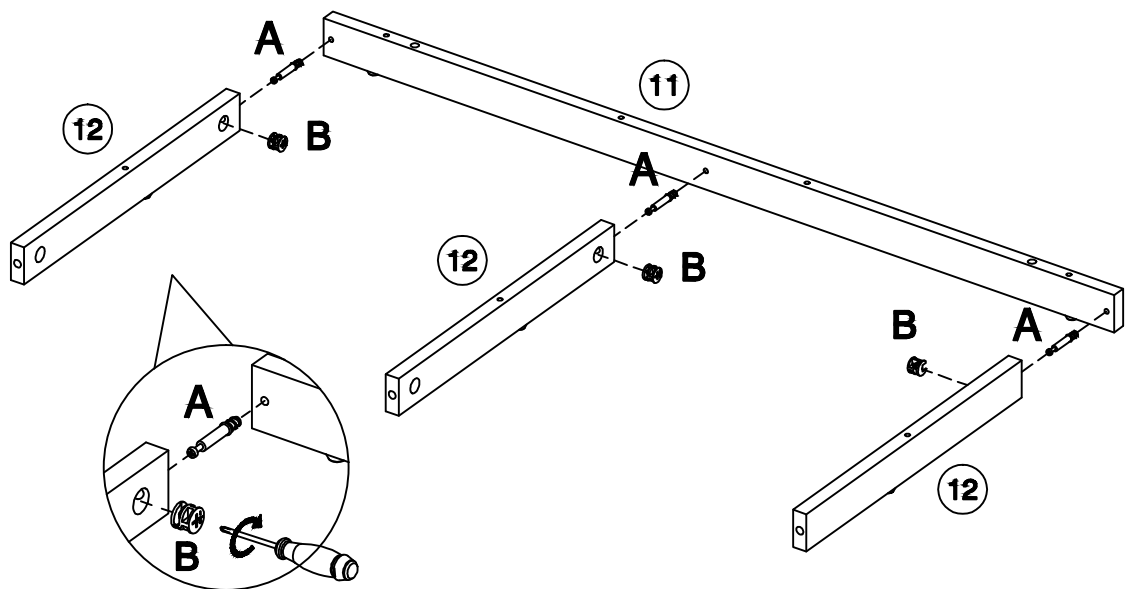
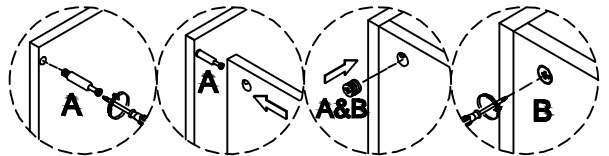
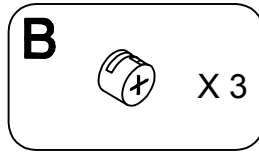
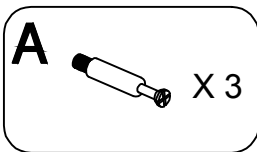

Step 8

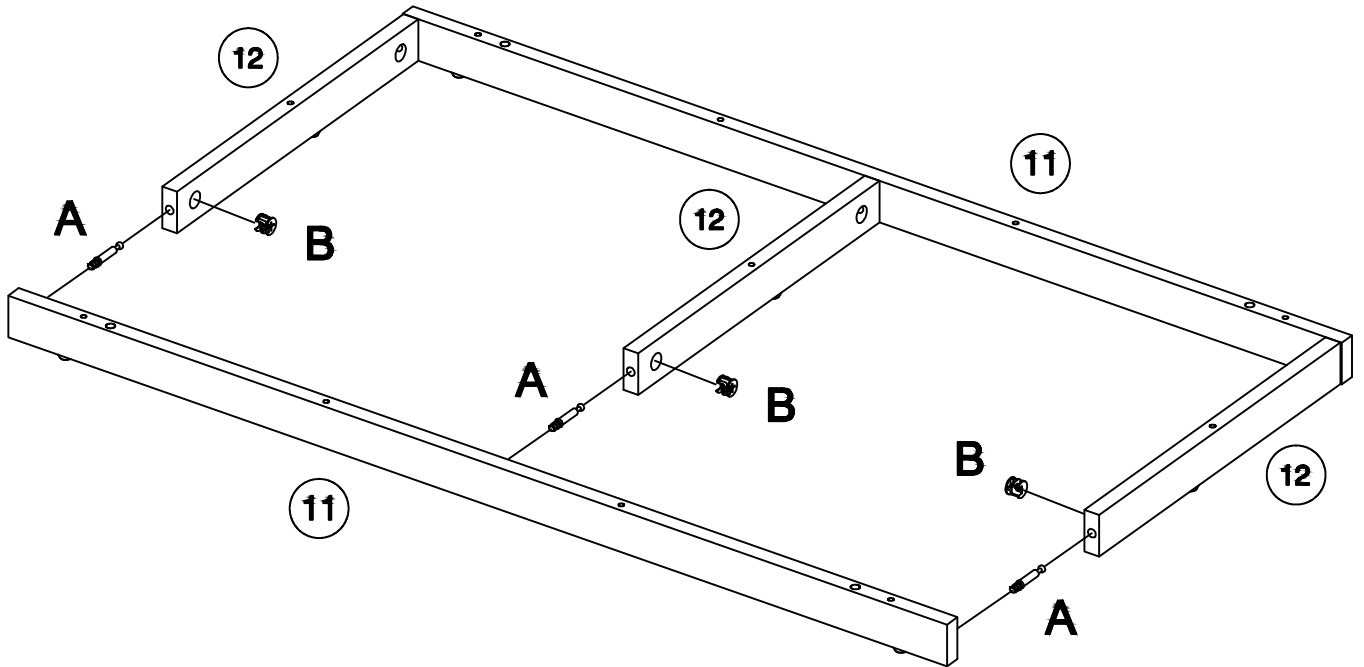
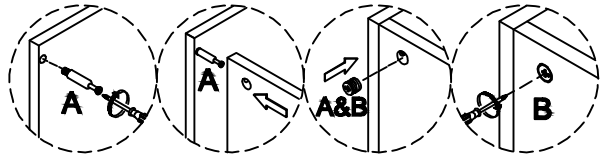
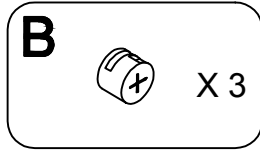
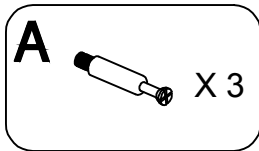

Step 9

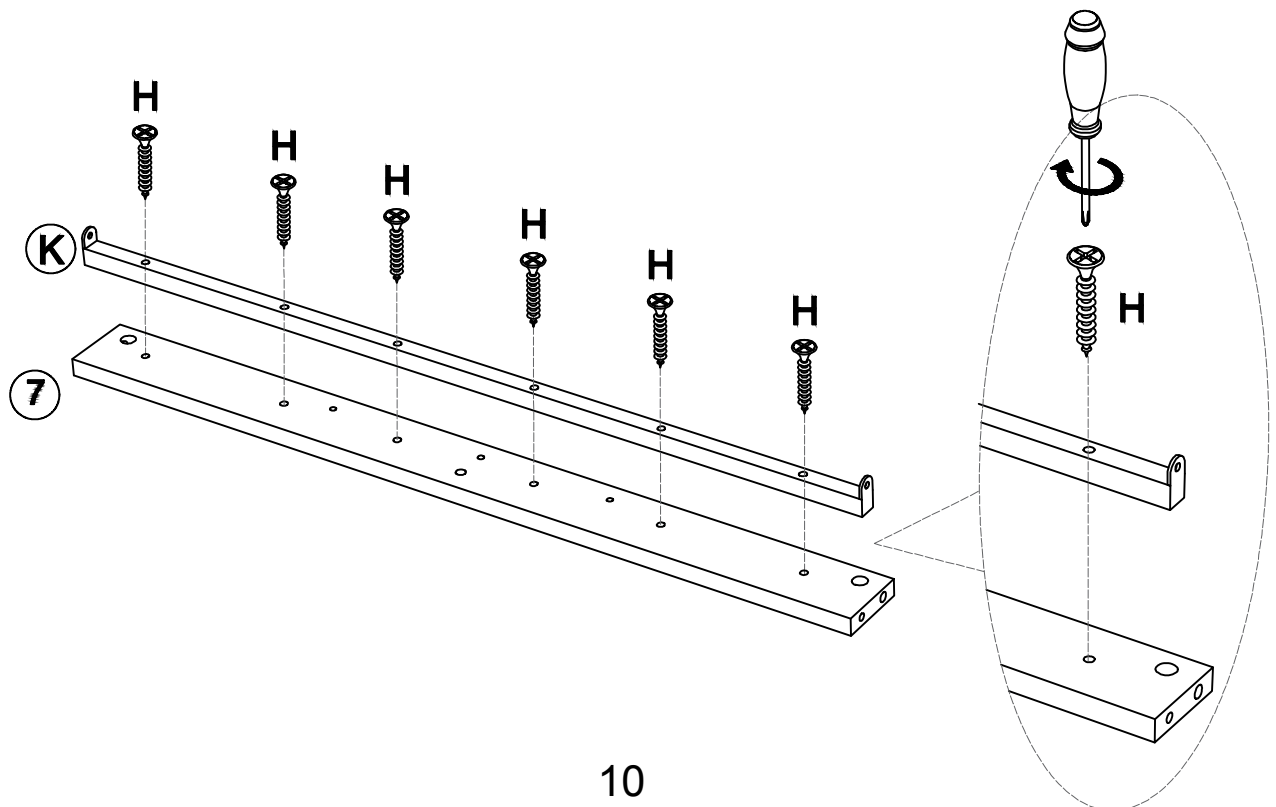
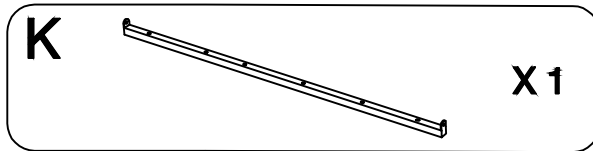
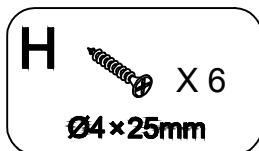

Step 10

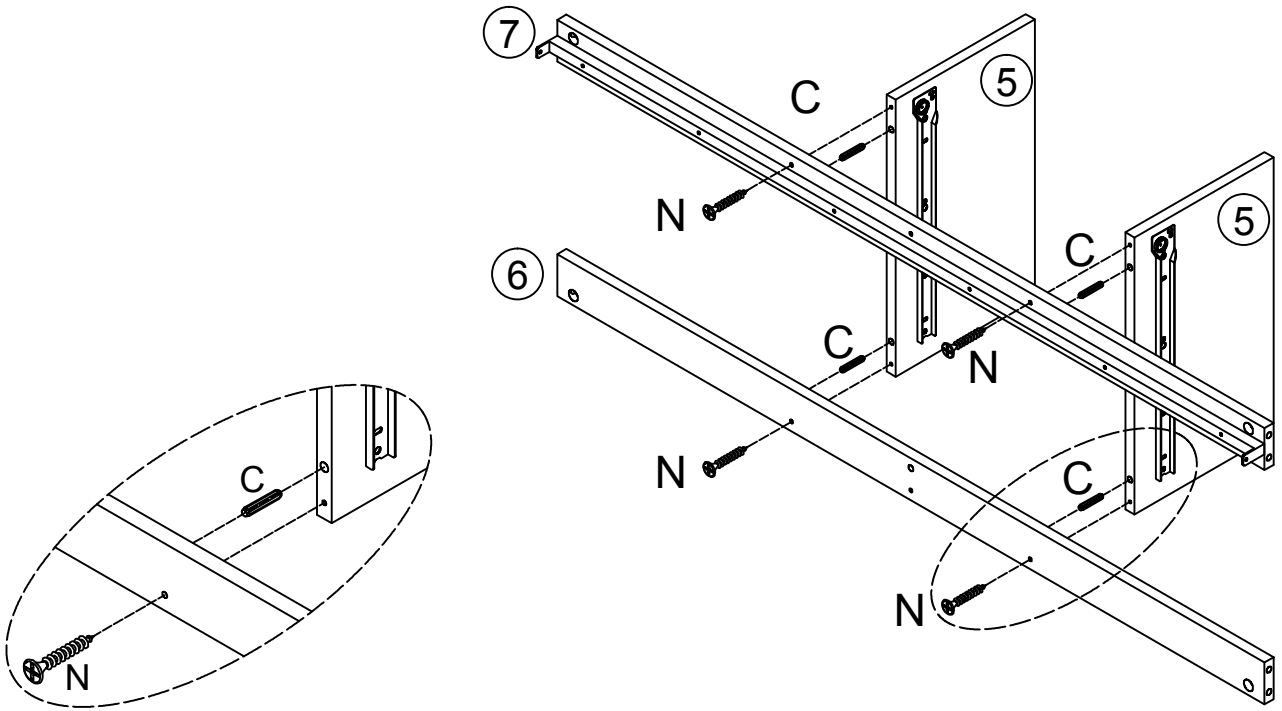
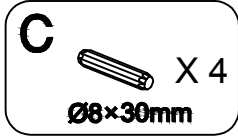

Step 11

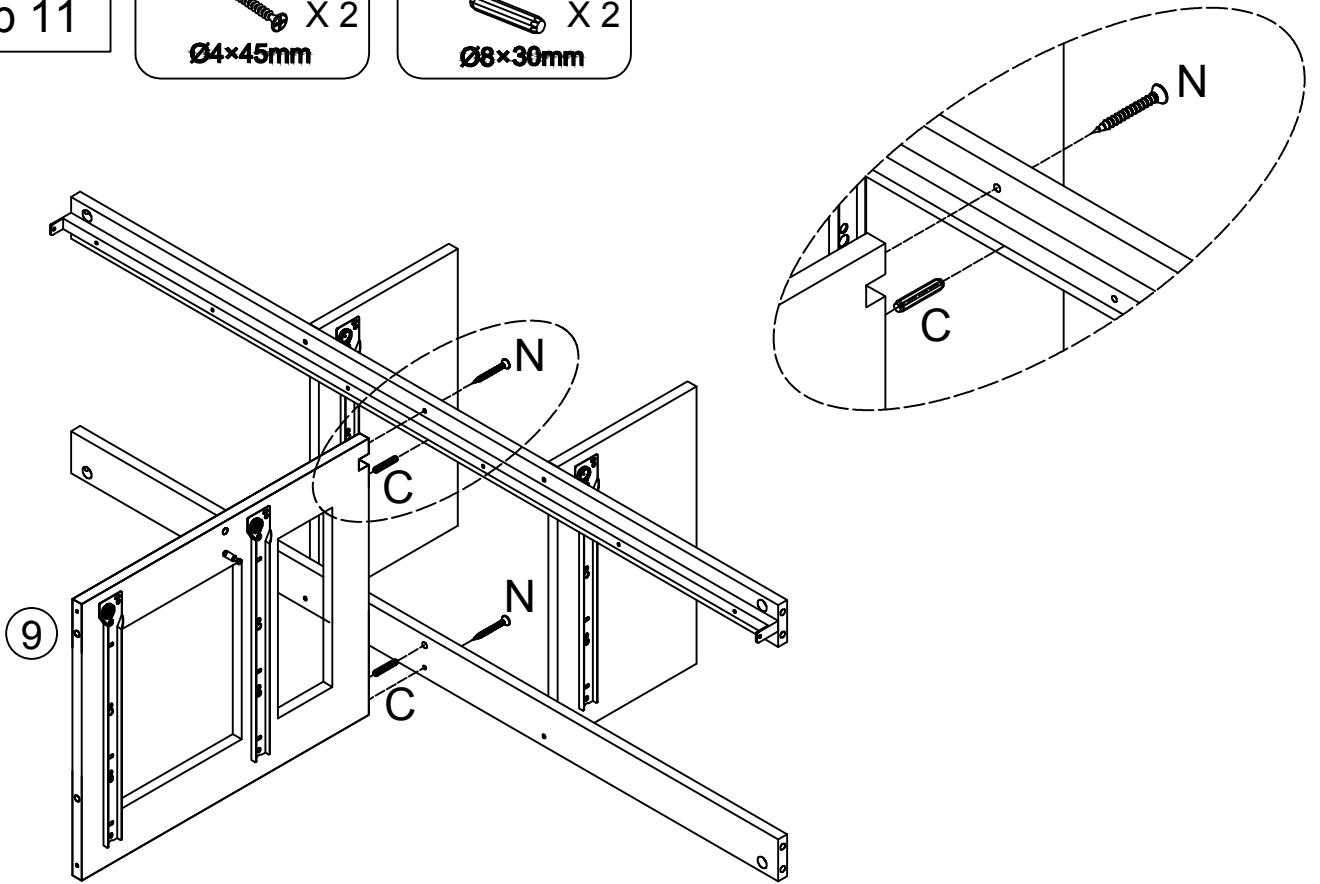
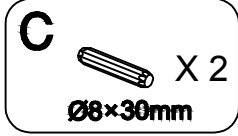

Step 12

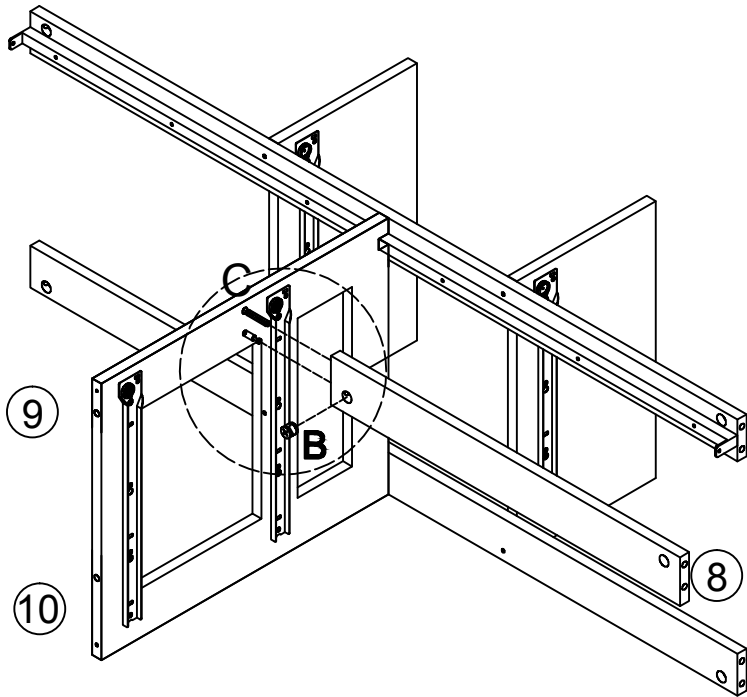
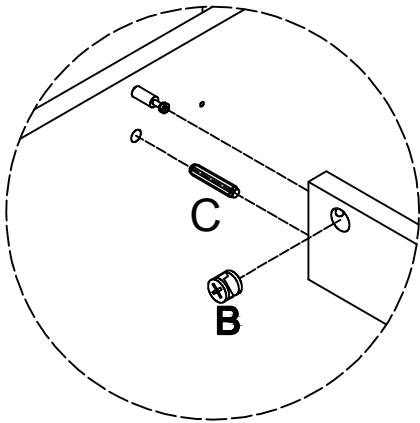
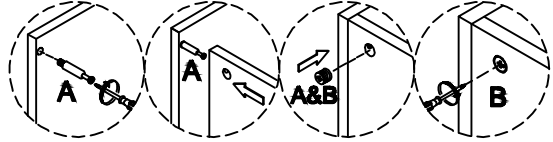
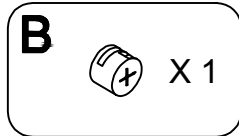
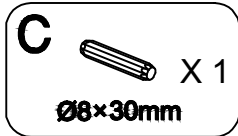

Step 13

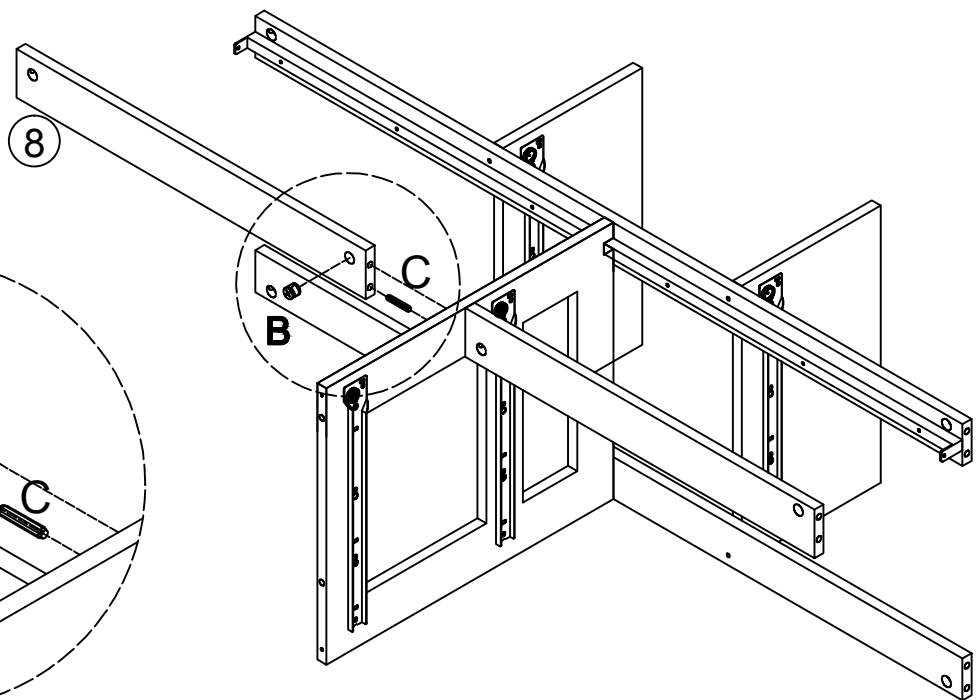
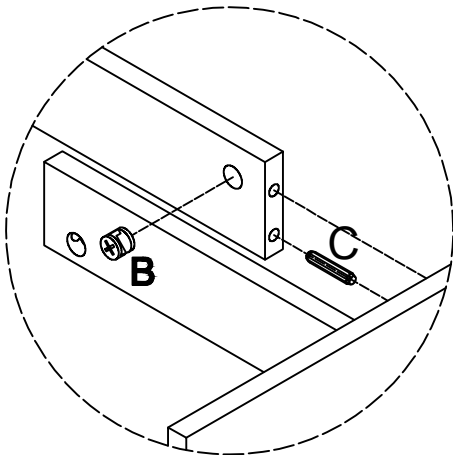
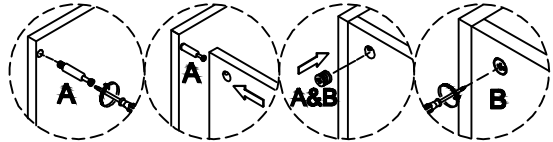
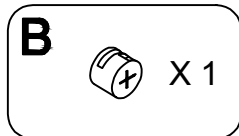
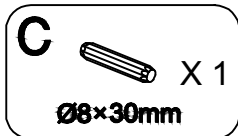

Step 14

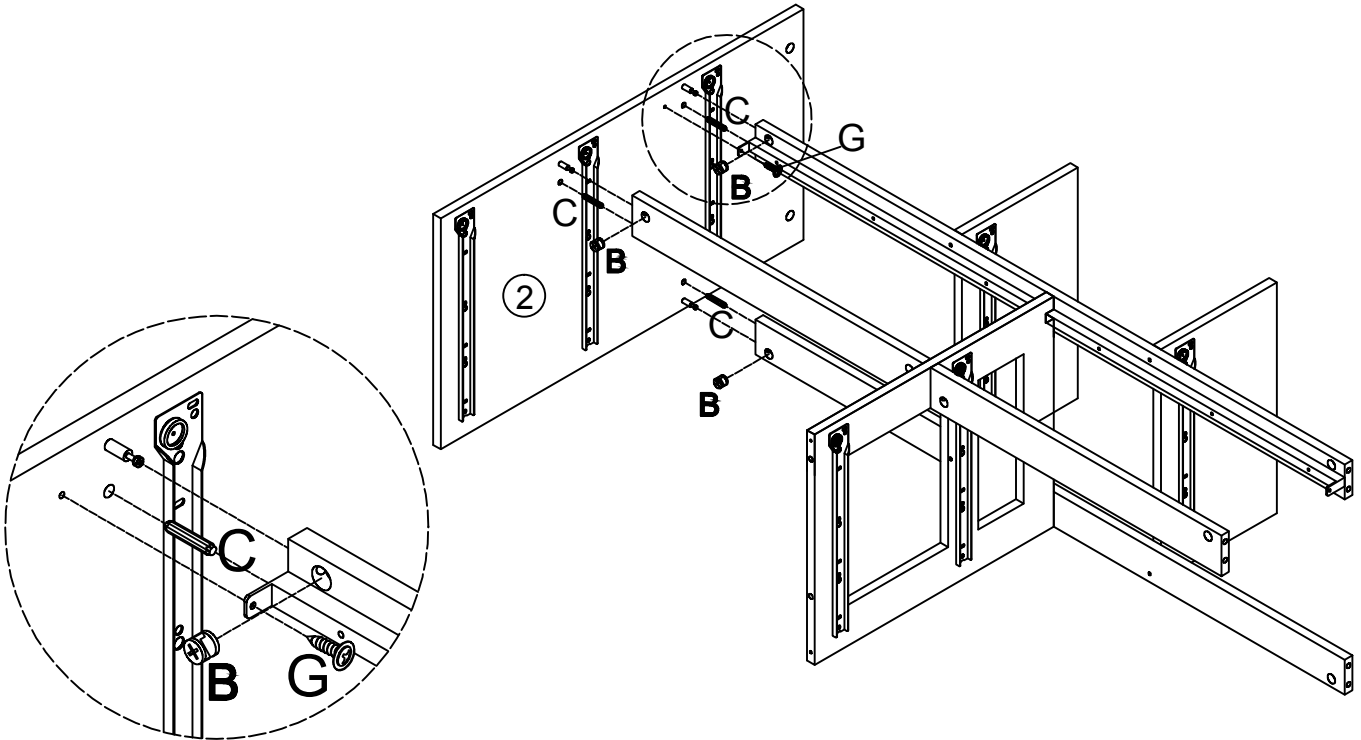
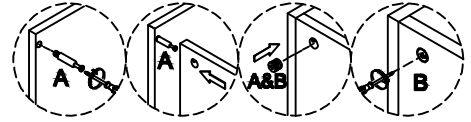
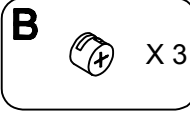
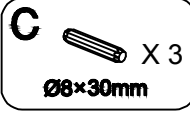

Step 15

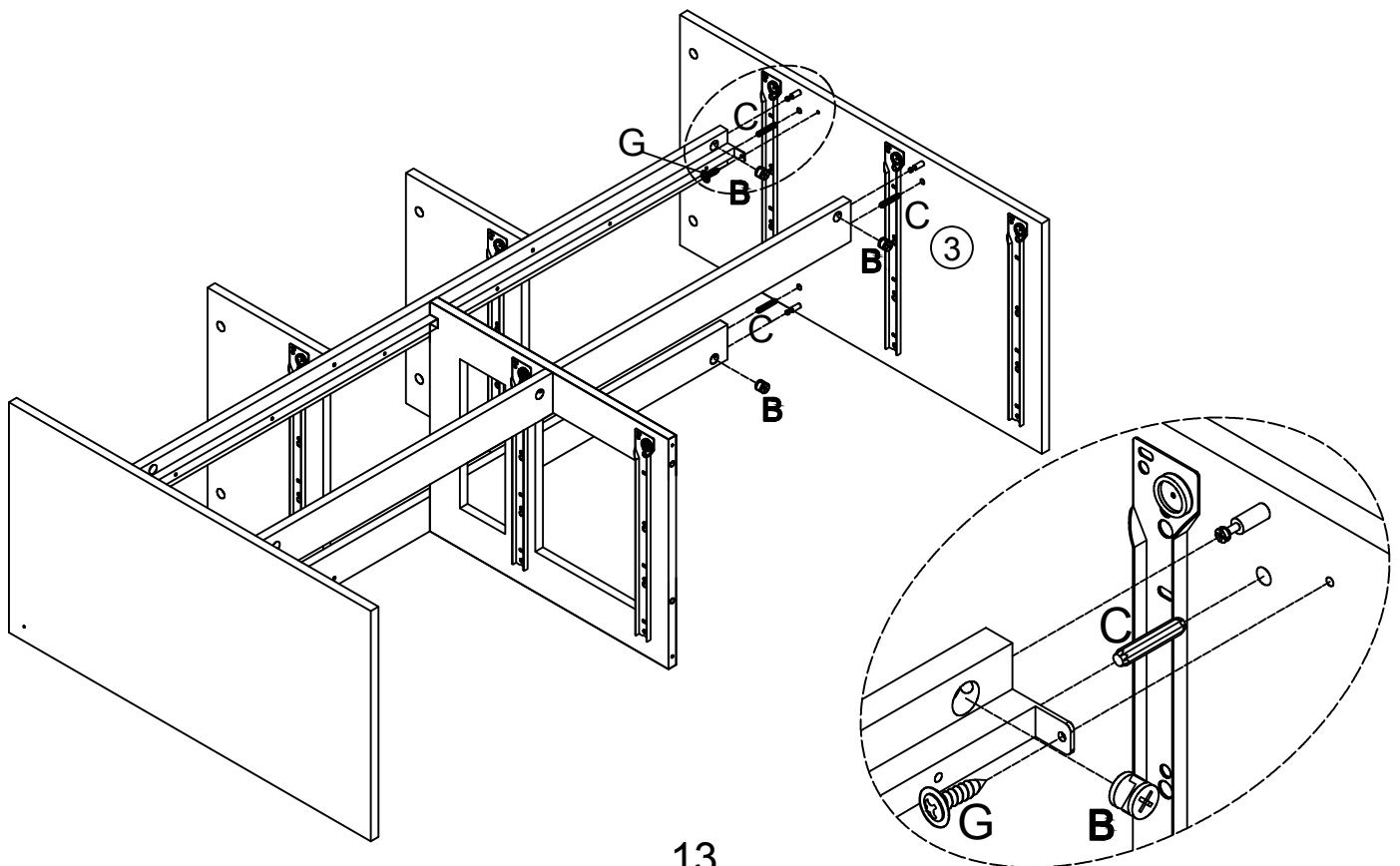
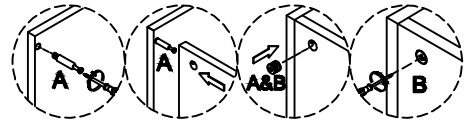
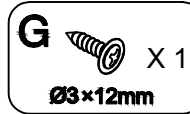
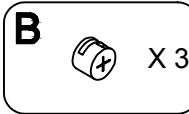
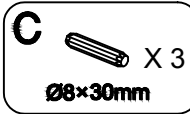

Step 16

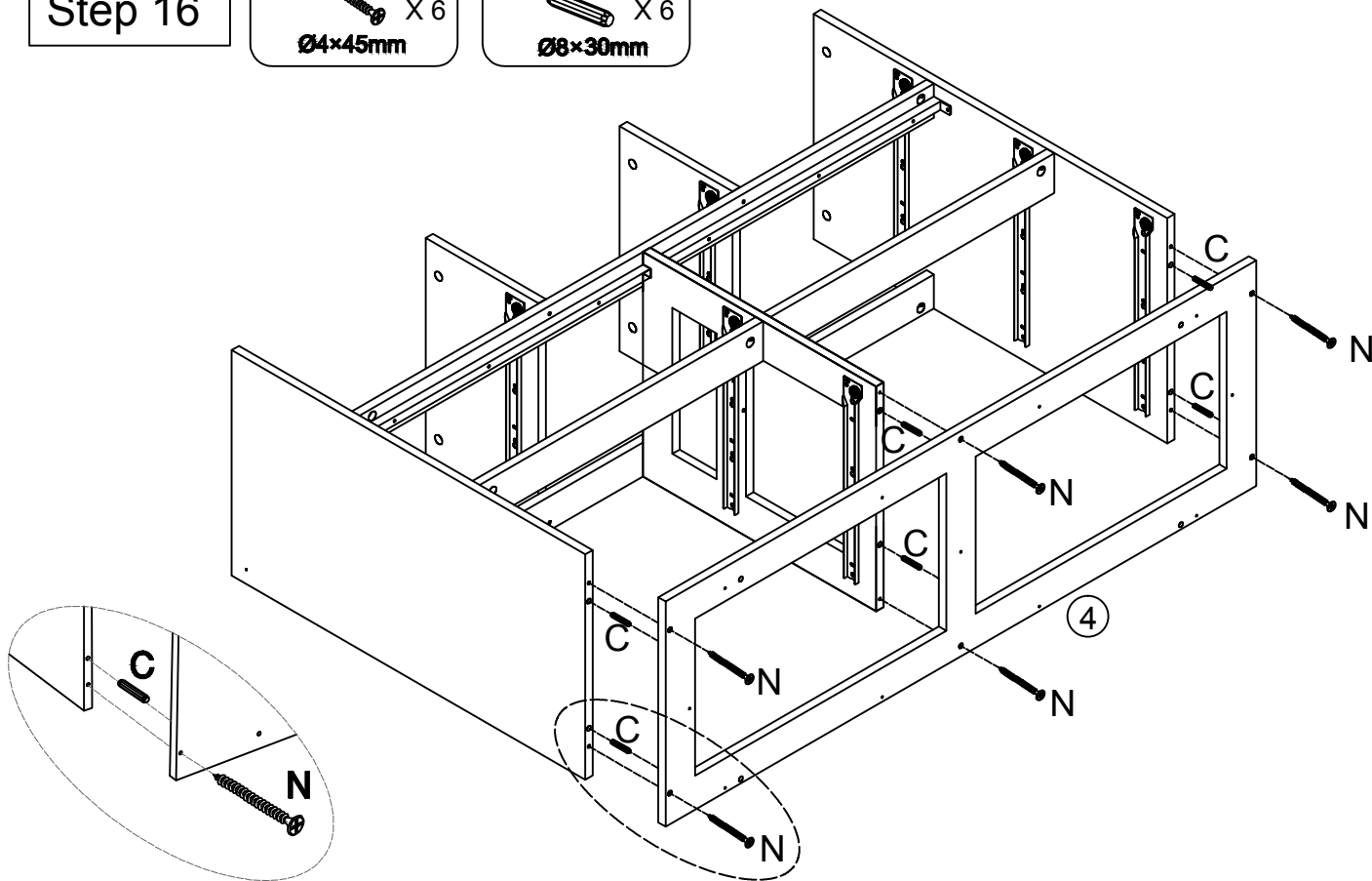
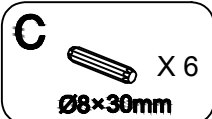

Step 17

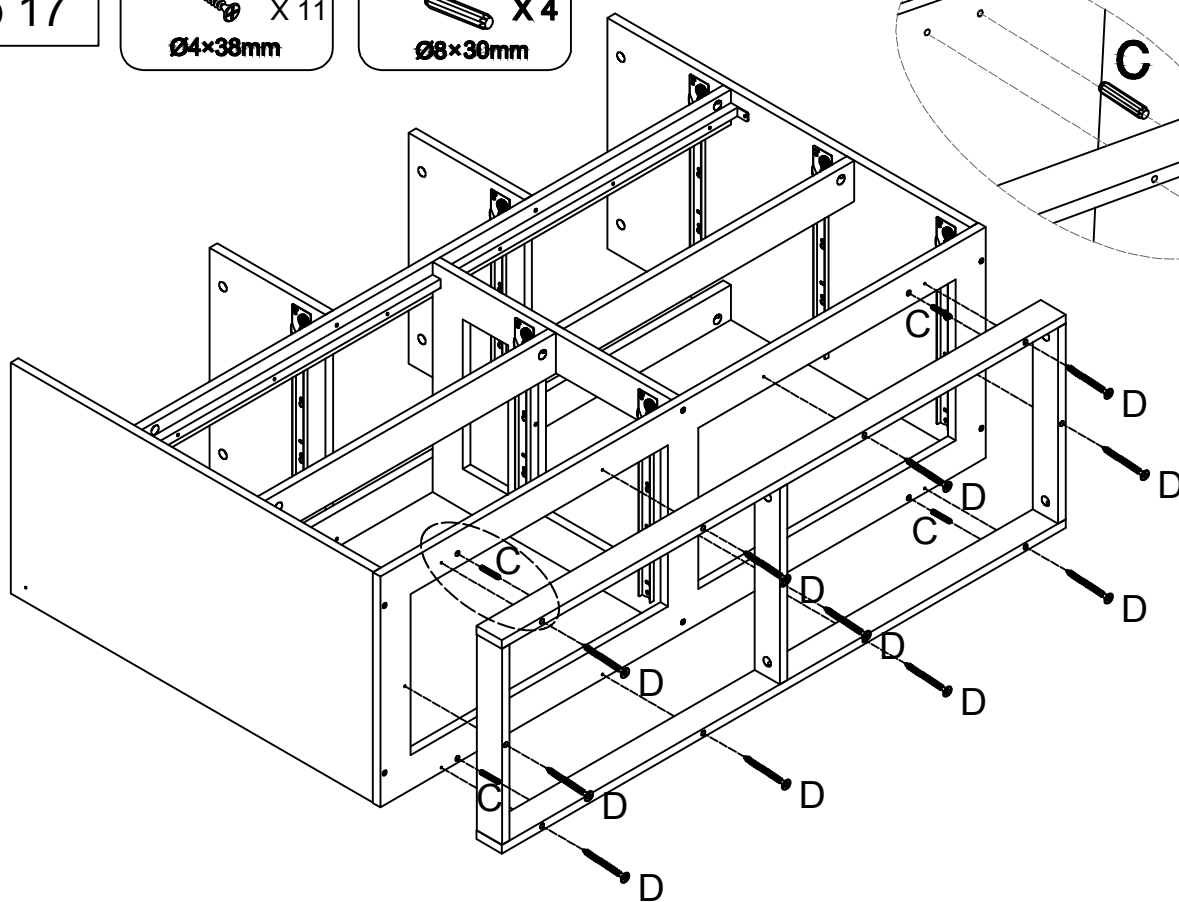
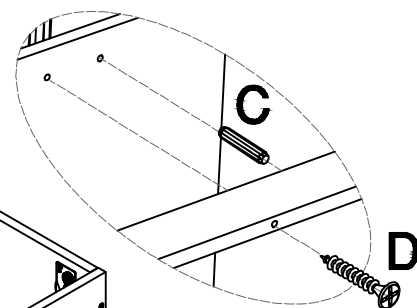
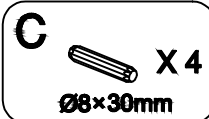

Step 18

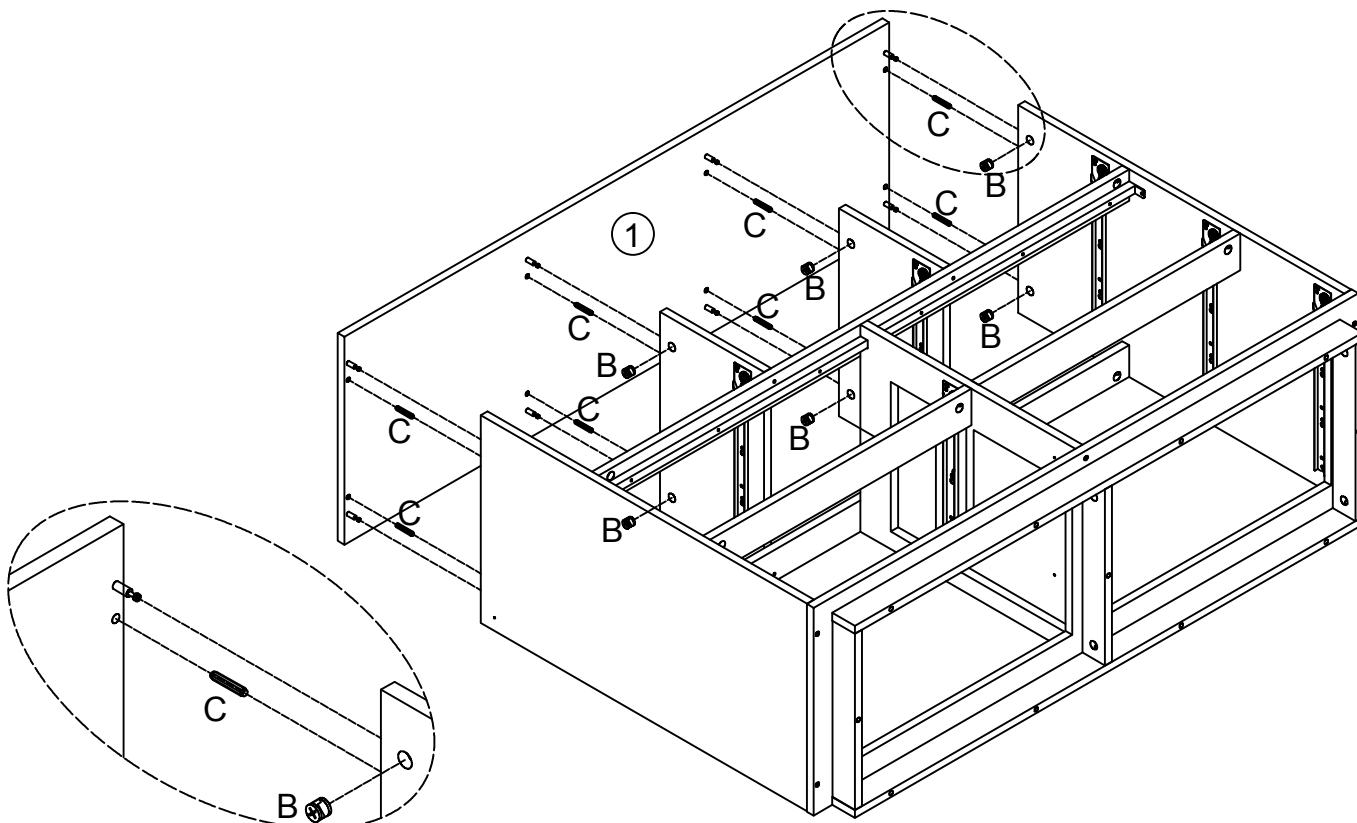
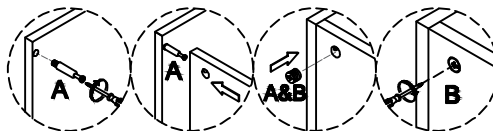
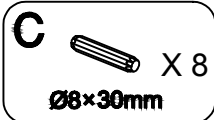
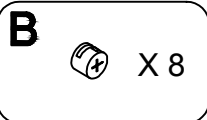

Step 19

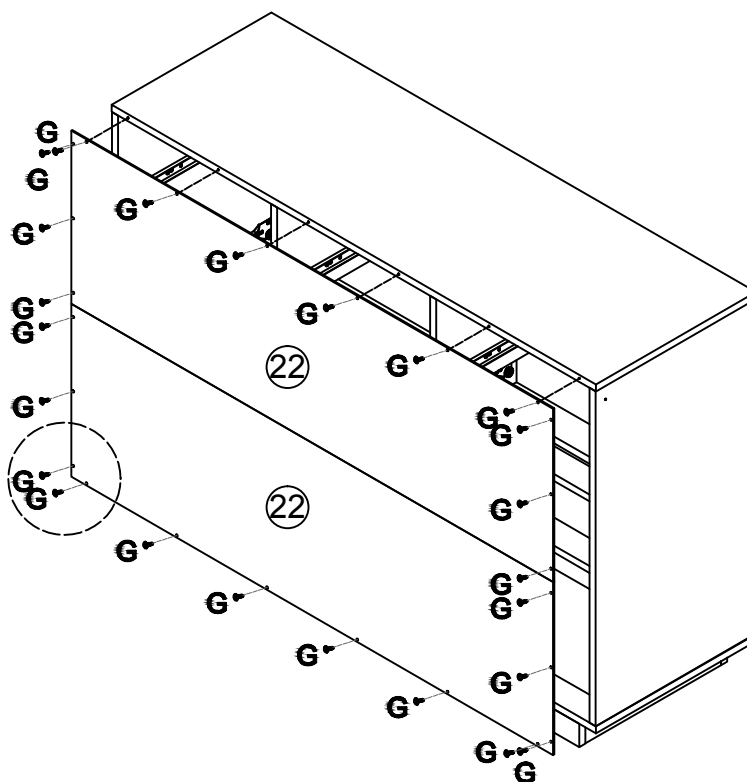
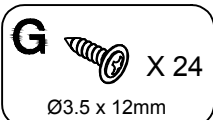

Step 20

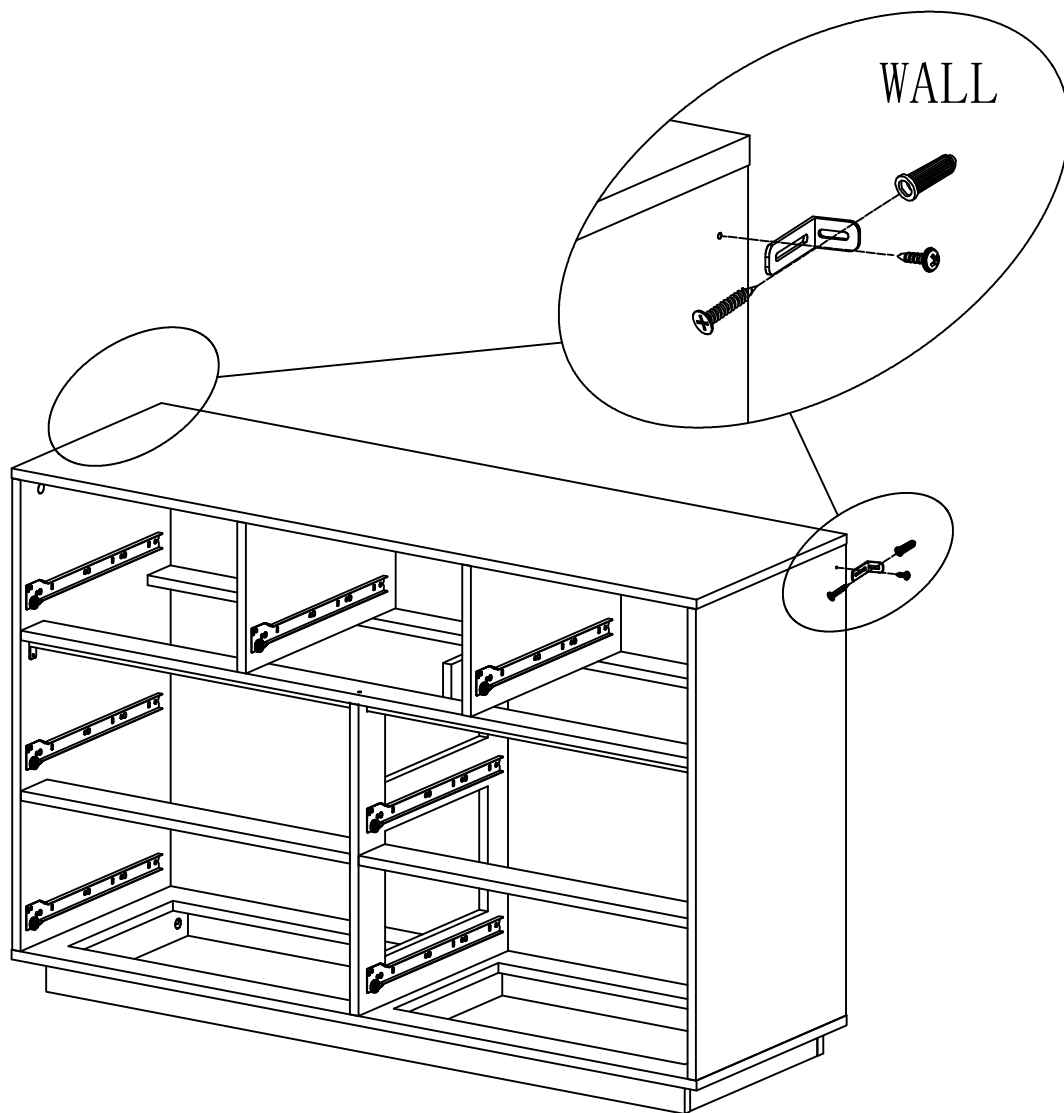
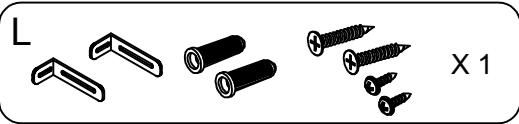

Step 21

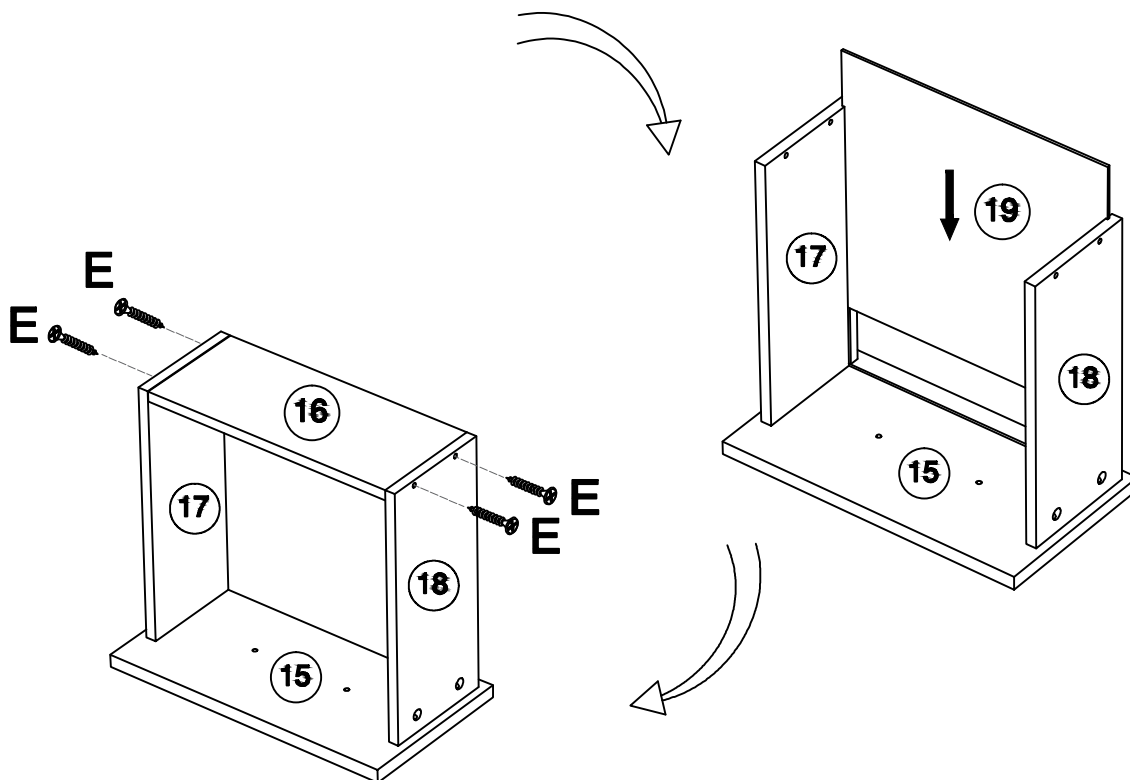
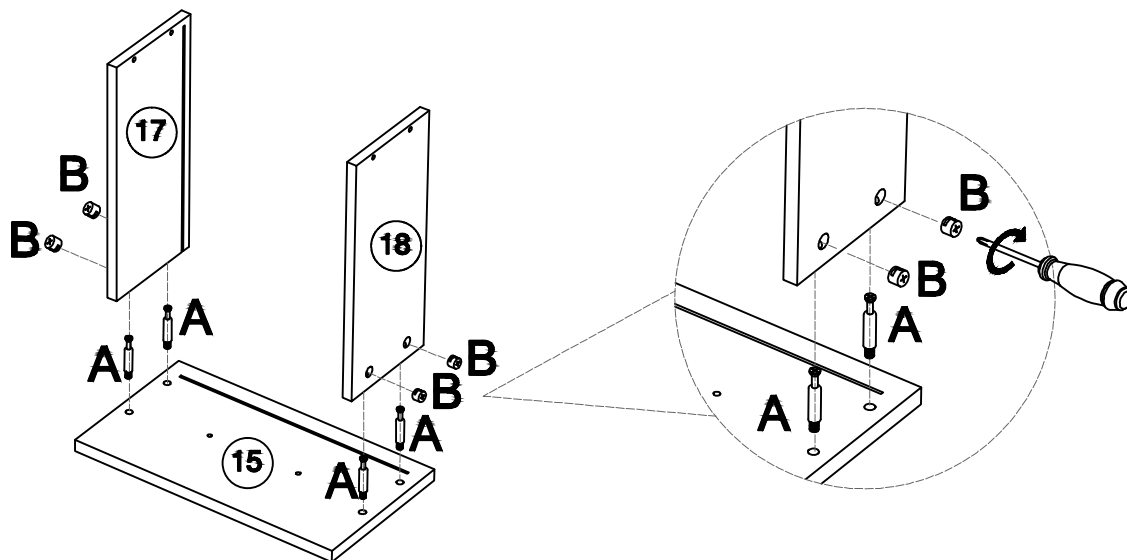
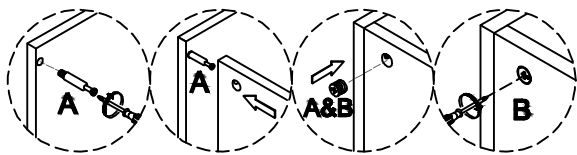
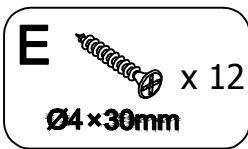
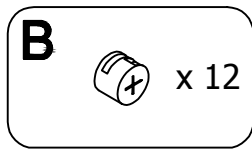
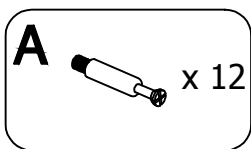

x 3

# Step 22

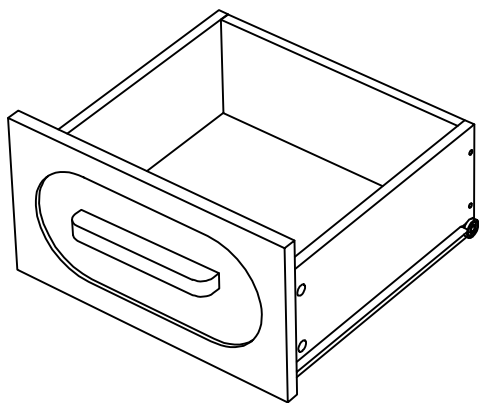
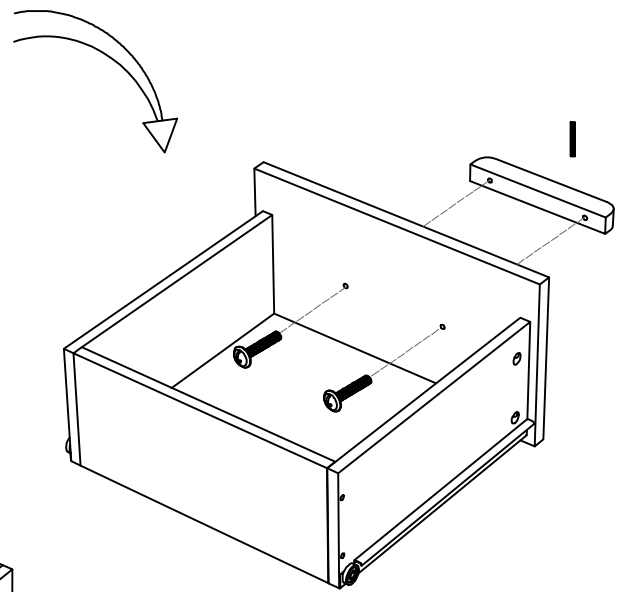
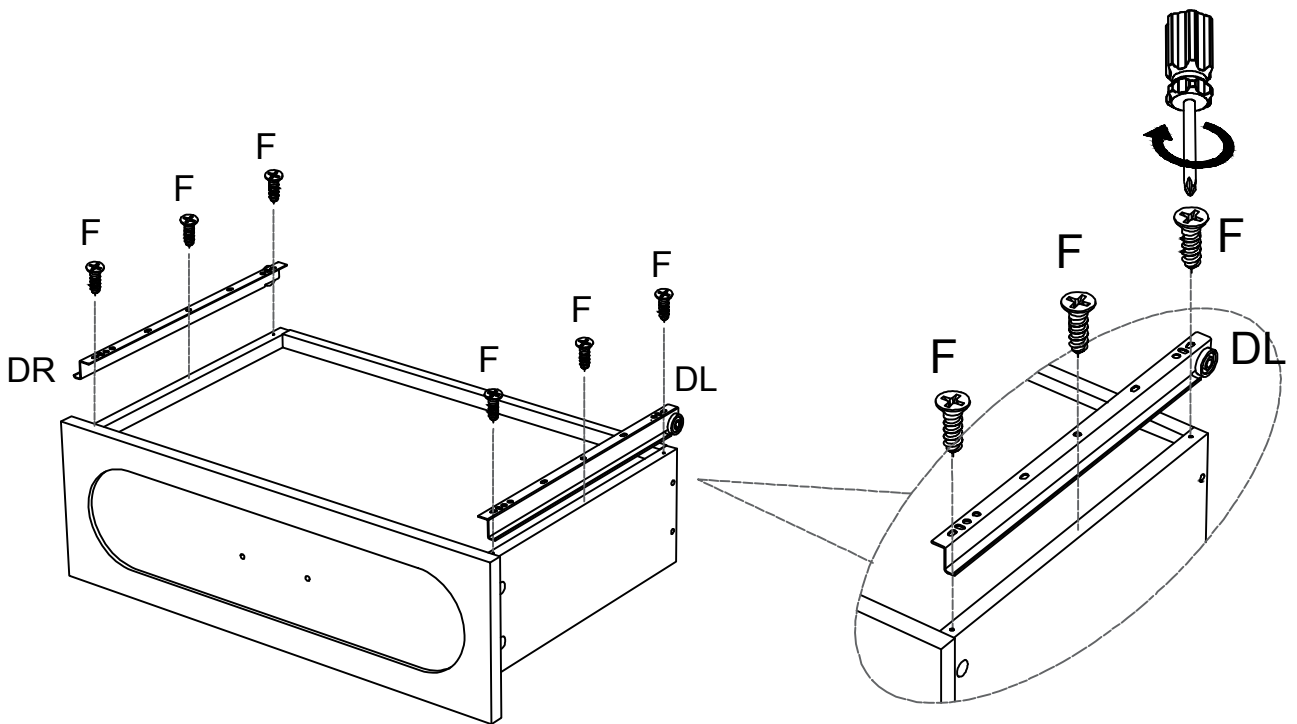
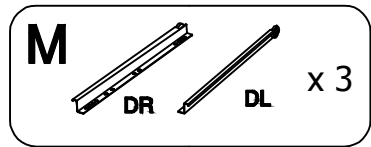
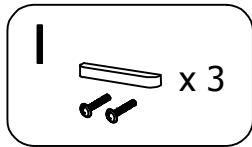
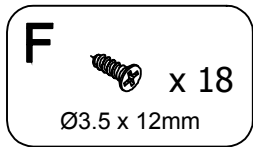

x 3

Step 23

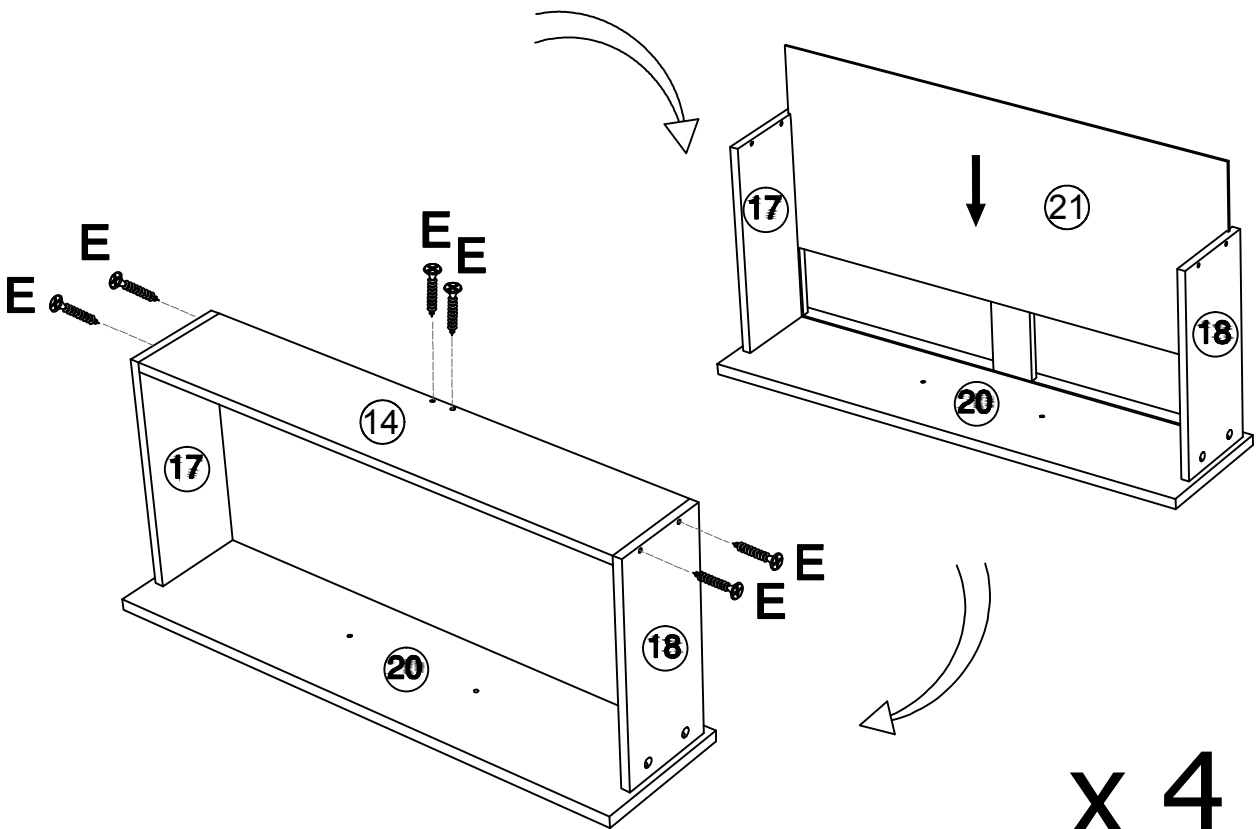
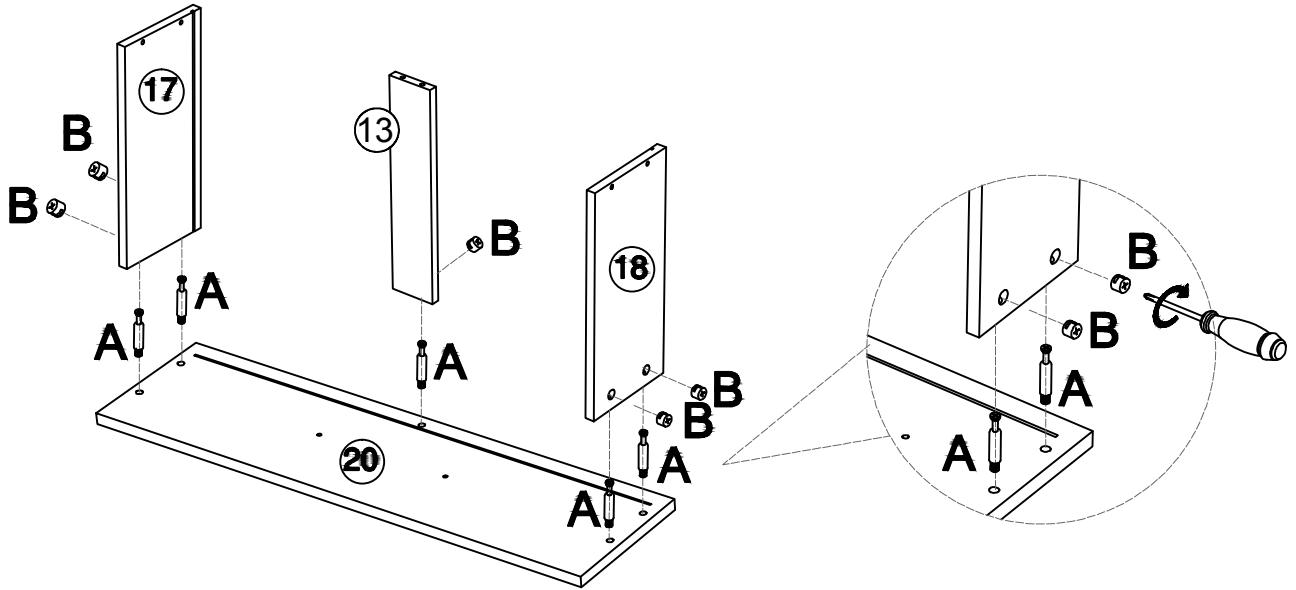
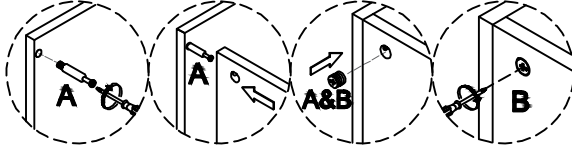
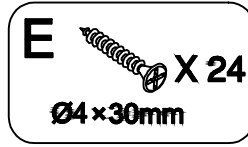
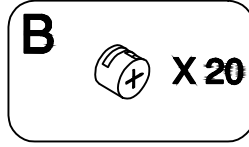
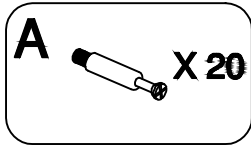

Step 24

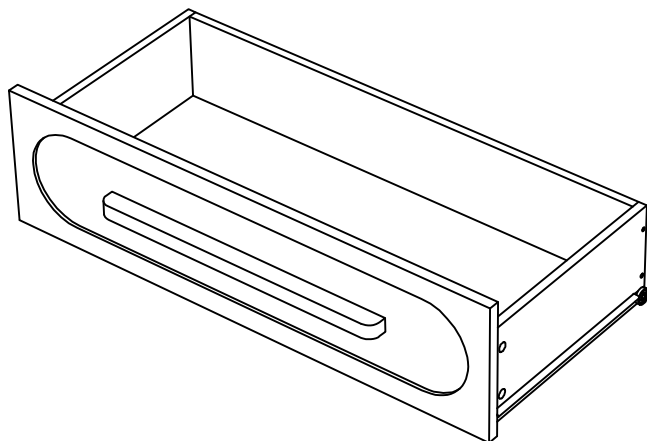
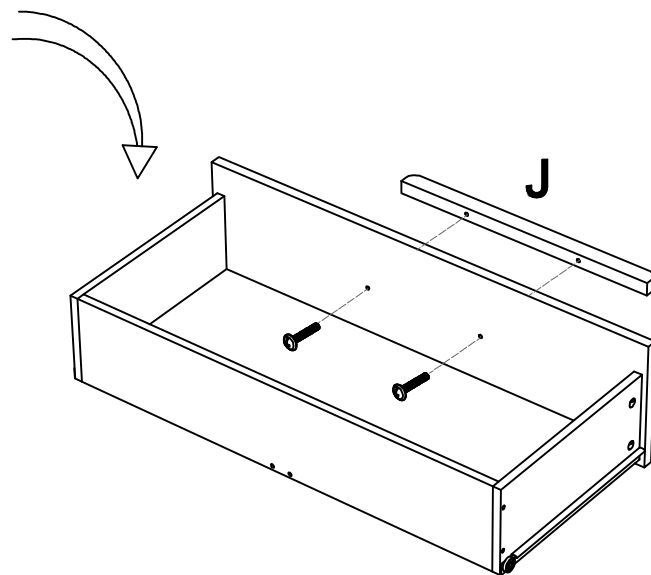
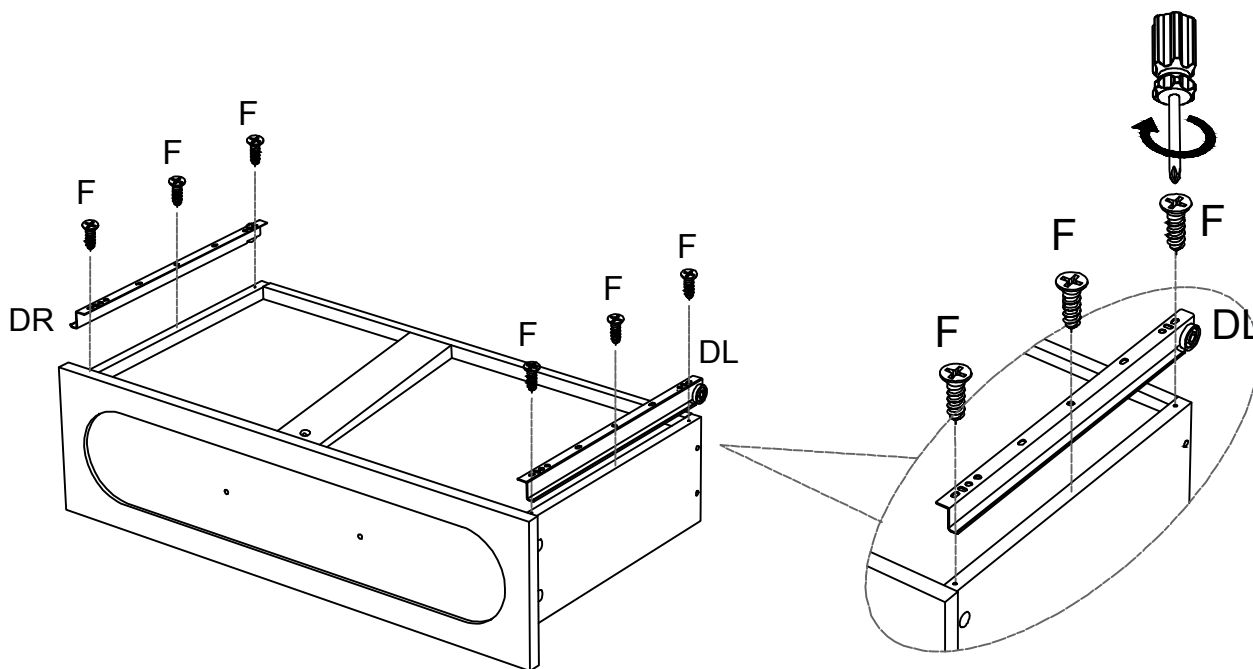
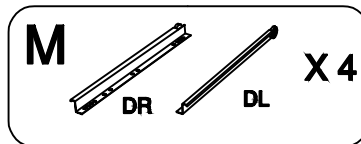
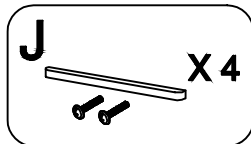
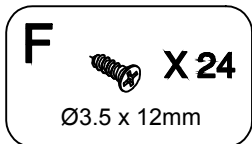

**x 4**

Step 25

