

USER MANUAL

Entryway Cabinet Model: JY-260114

TOOLS REQUIRED

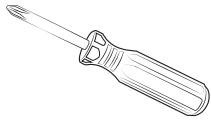

Phillips screwdriver
(Not included)

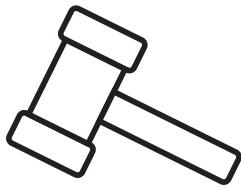

Hammer
(Not included)

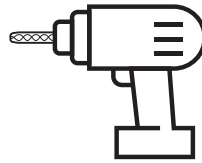

Drill
(Not included)

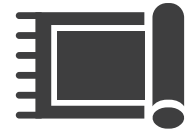

Protective blanket
(Not included)



ATTENTION

Keep children and pets away while assembling.



How to use cam locks

CAM LOCK FASTENING SYSTEM

This Cam Lock Fastening System will be used throughout the assembly process.

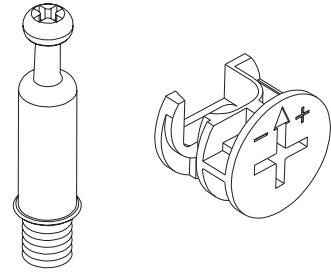

1

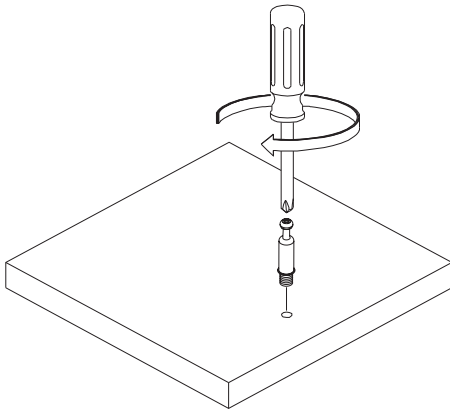

2

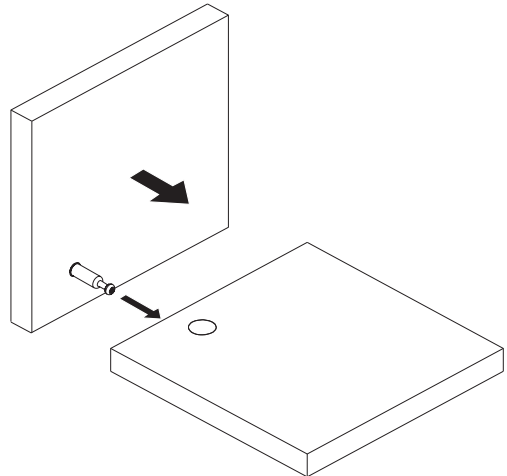

3

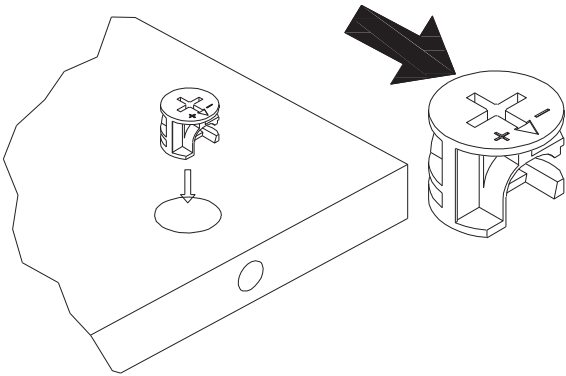

4

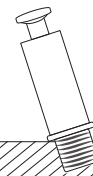
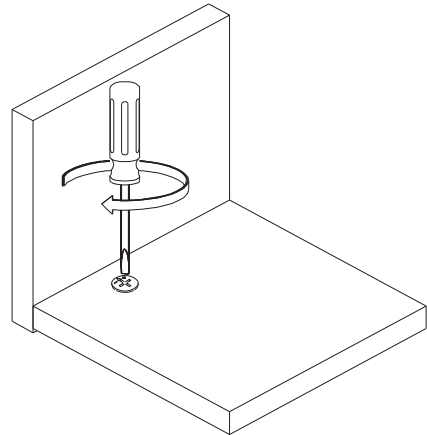

INTRODUCTION

Thank you for choosing our products. Please read the instructions carefully and keep them for future reference. If you need further assistance, please contact our customer service online via email.

PRECAUTIONS

1. When installing the product, use a soft underlay (such as carpet or cardboard) to avoid scratching or damaging the surface of the product.
2. Please try to use a manual screwdriver instead of electric screw driver. A manual screwdriver can be used to better control the tightness of the screws.
3. Do not use any glue.
4. The product is unstable before it is assembled. Please pay attention to the product installation sequence.
5. The structure of this product can not meet the requirements of the placement of heavy items and children climbing.





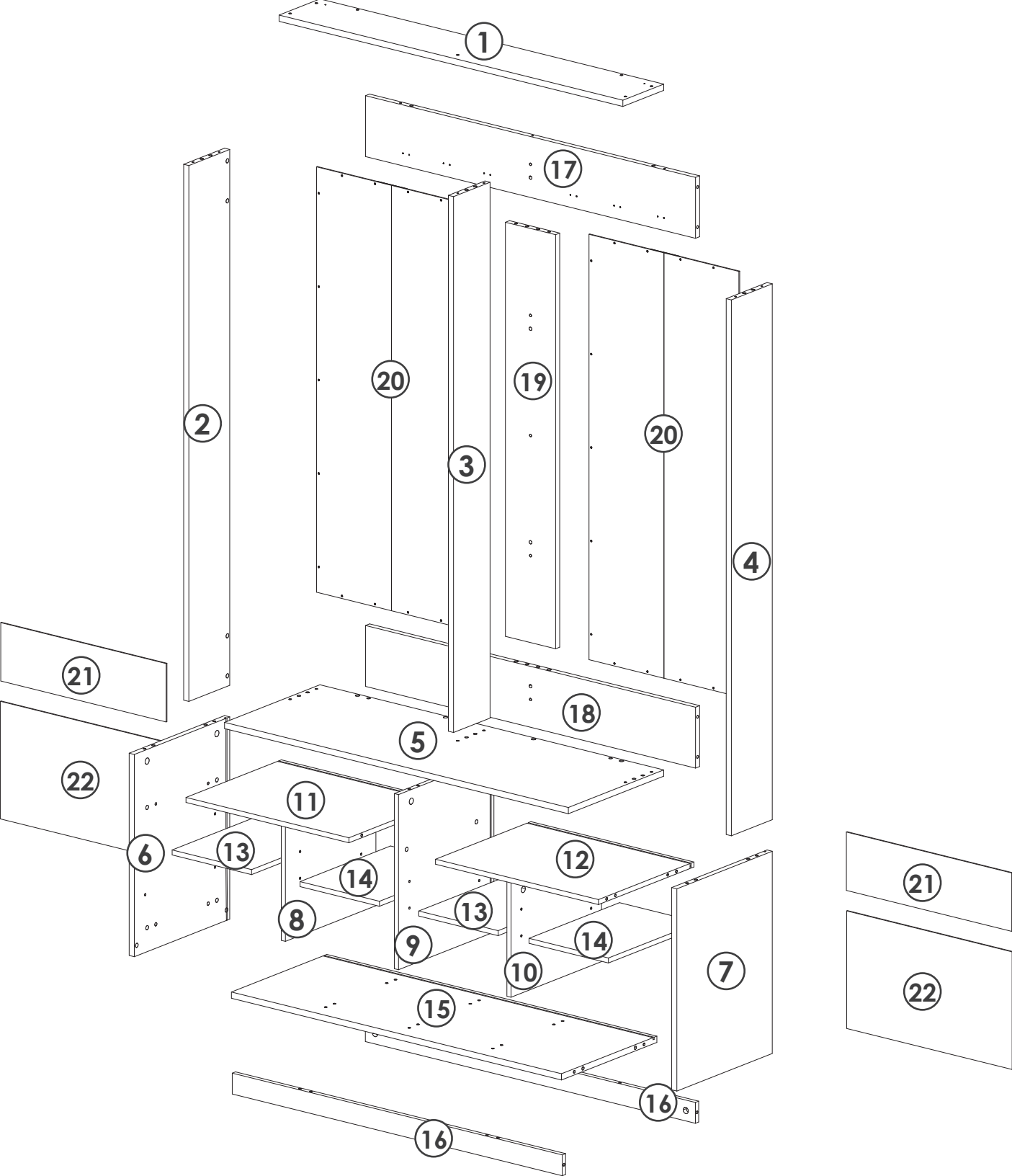

WARRANTY

We provides an **18 Month** Warranty on all products starting from the date of original purchase. If the product has any manufacturing defect, please contact customer service via email with your order number and other details to the problem. We will send you further information about the return or exchange.

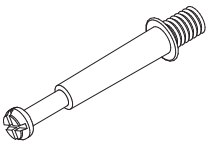
PACKAGE CONTAINS

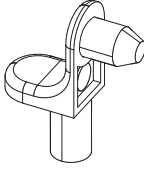
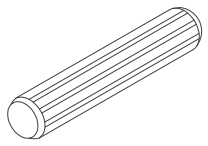
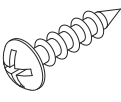
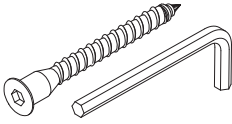

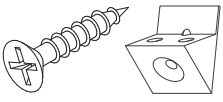
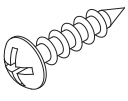
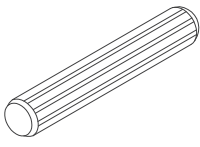
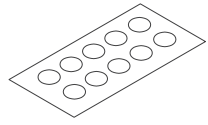
HARDWARES LIST

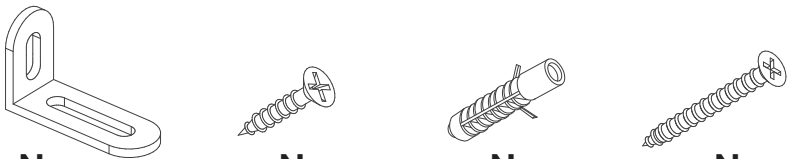
<p>A x42</p>  <p>M6*35mm</p>	<p>B x42</p>  <p>M15*10mm</p>	<p>C x16</p> 	<p>D x36</p>  <p>M8*40mm</p>
<p>E x12</p>  <p>M3.5*14mm</p>	<p>F x26/x1</p>  <p>M5*40mm/#3</p>	<p>G x10</p>  <p>Ø12*5mm</p>	<p>H x8</p> 
<p>J x36</p>  <p>M3.5*16mm</p>	<p>K x16</p>  <p>M6*40mm</p>	<p>L x6</p>  <p>21mm</p>	<p>M x6</p> 
<p>N x2</p>  <p>N1 N2 N3 N4</p>			

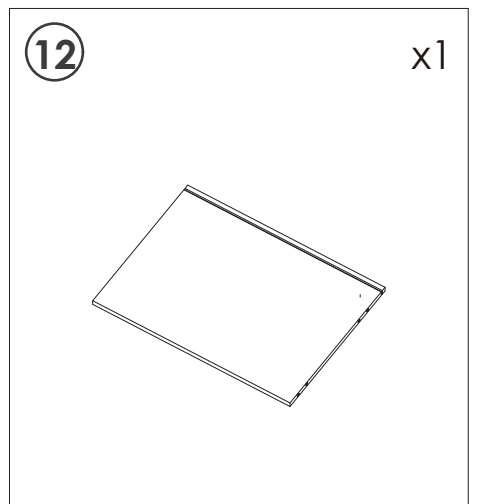
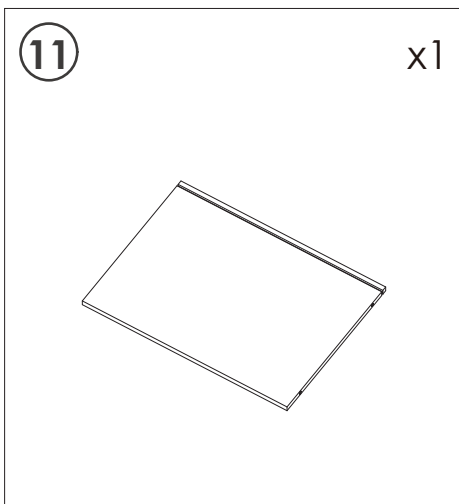
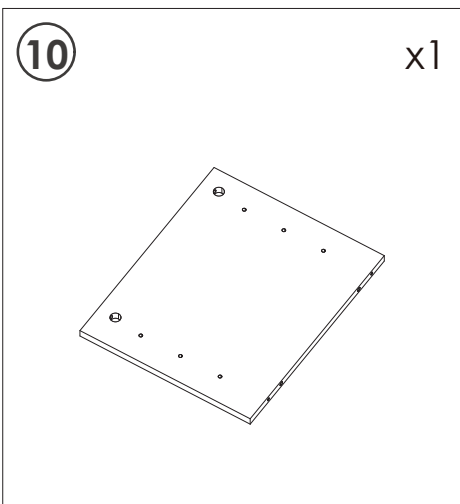
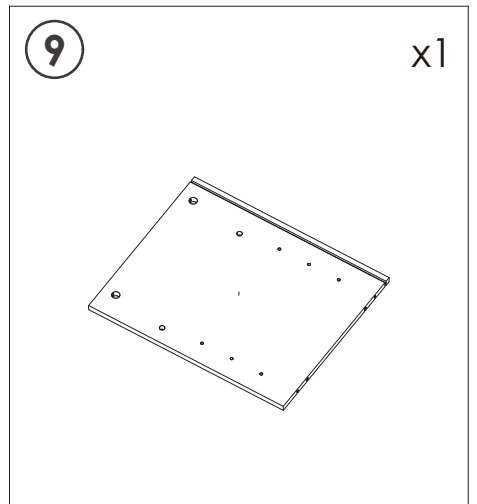
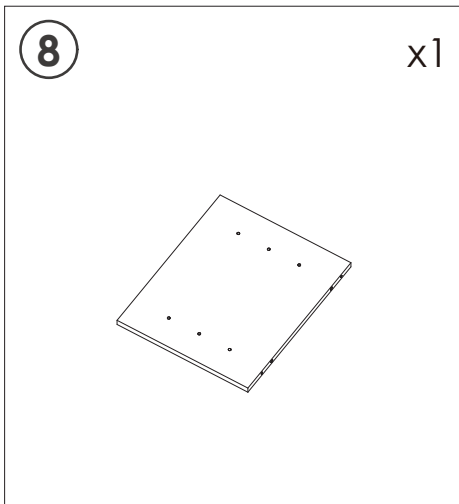
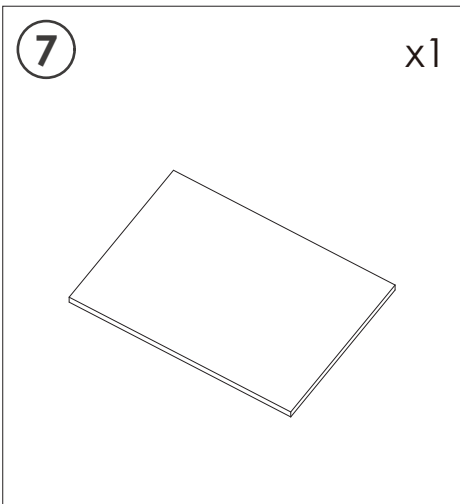
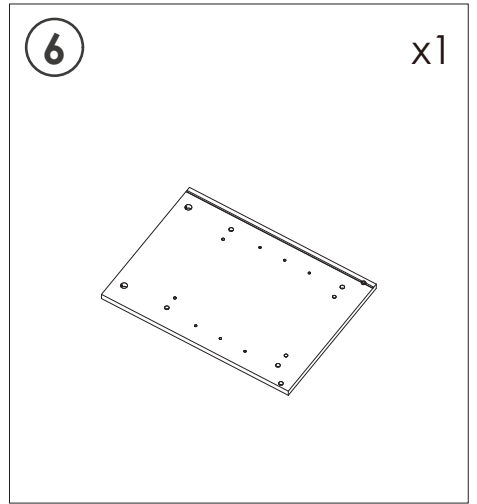
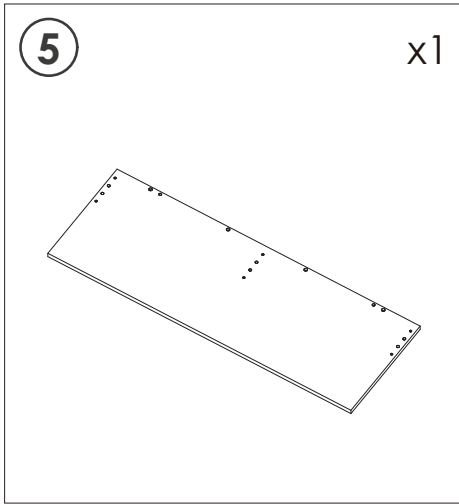
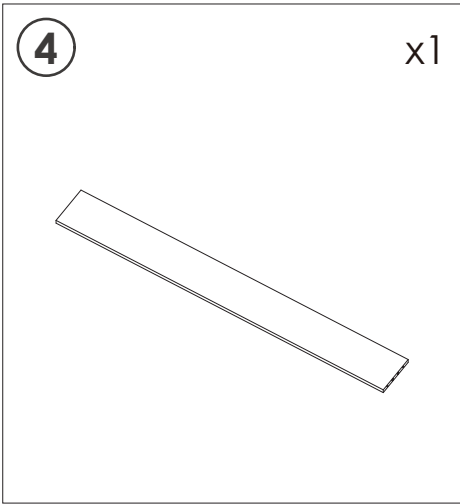
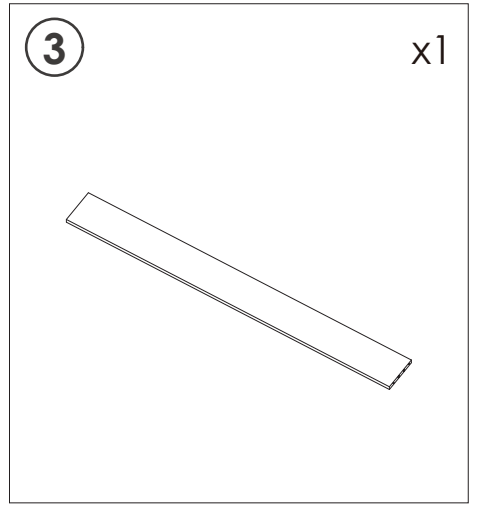
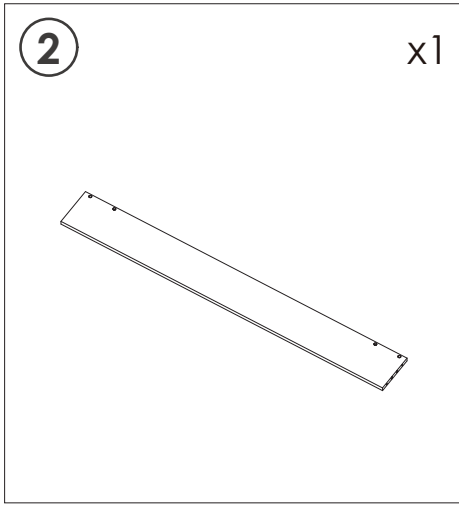
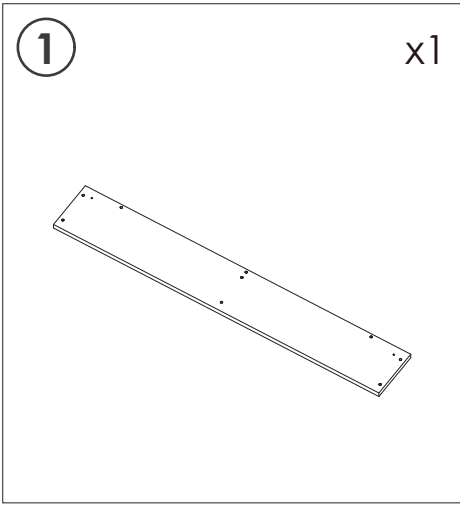

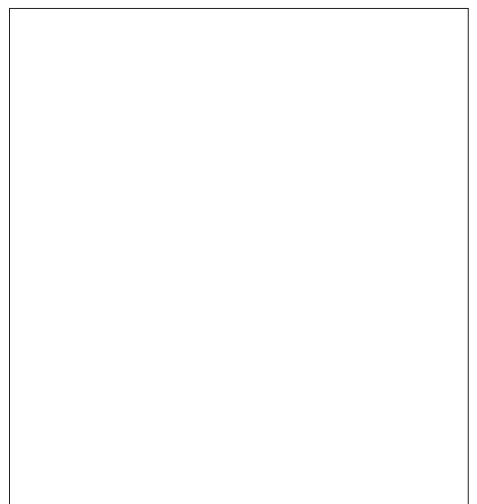
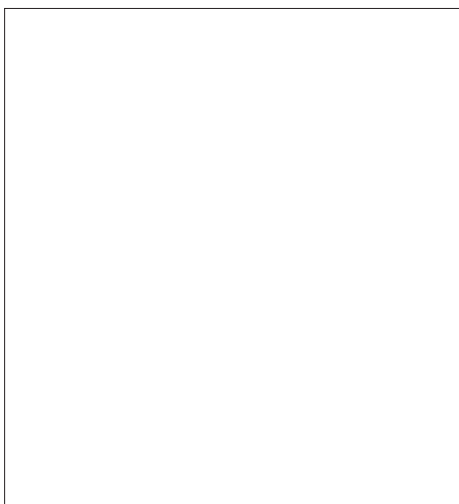
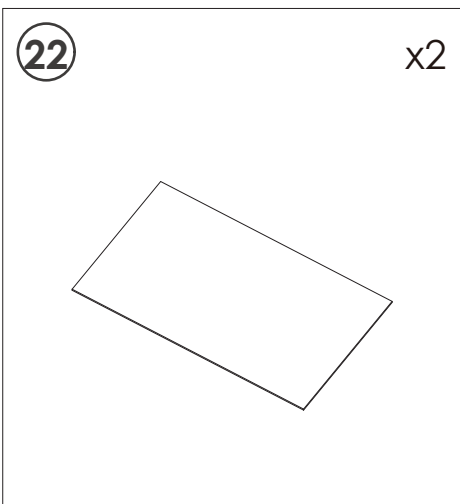
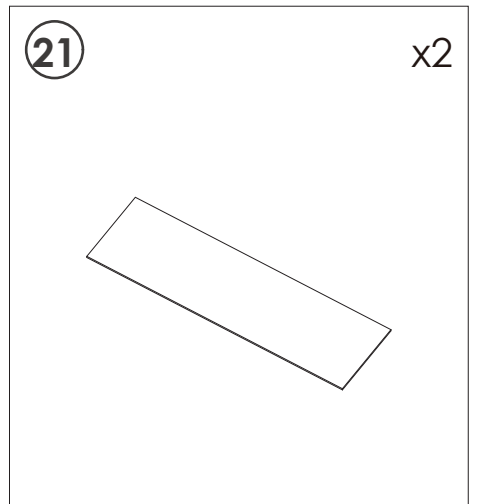
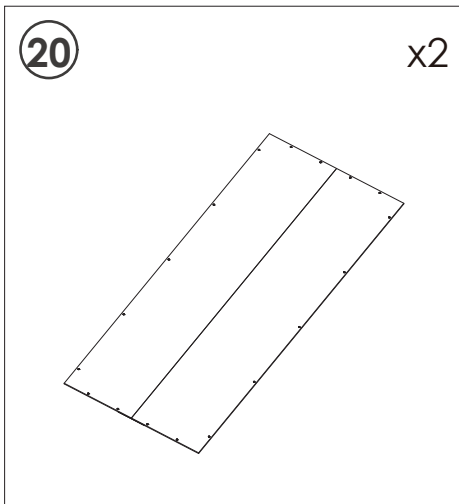
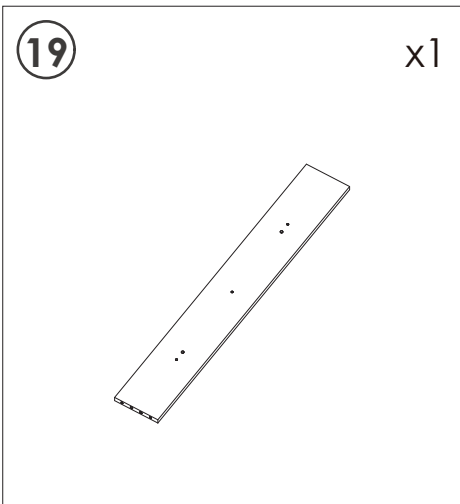
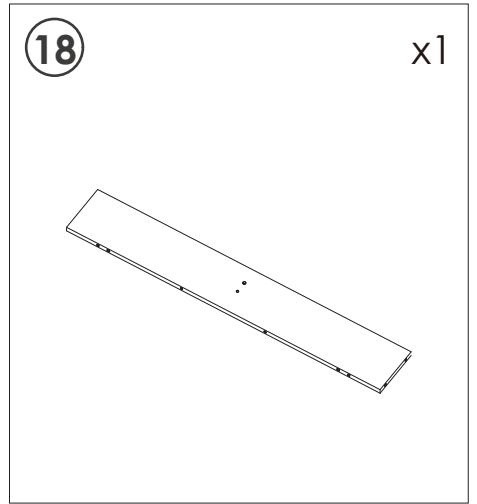
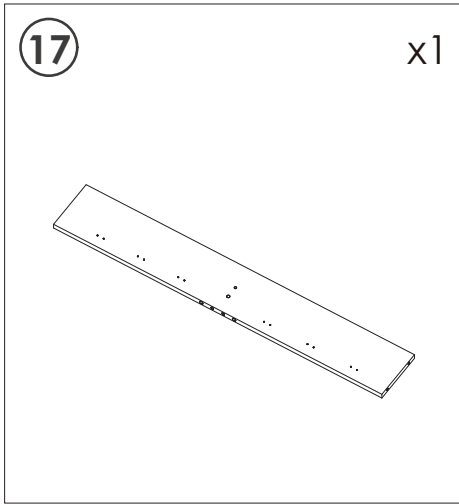
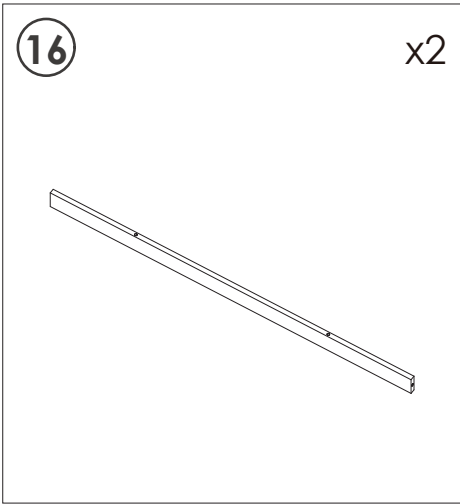
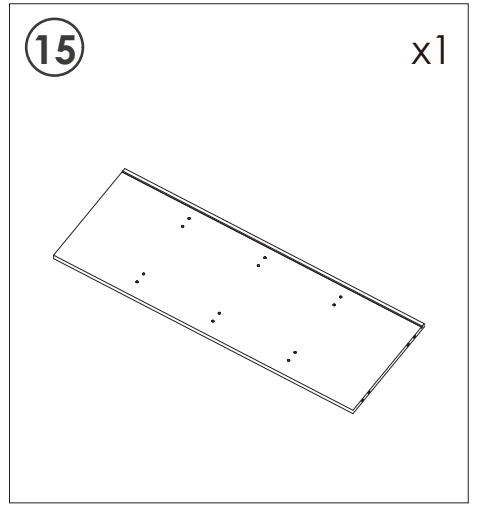
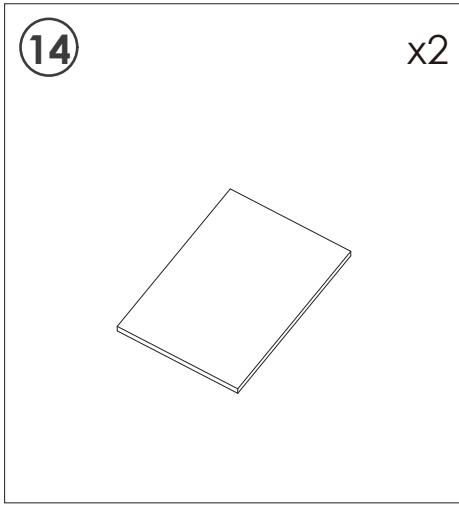
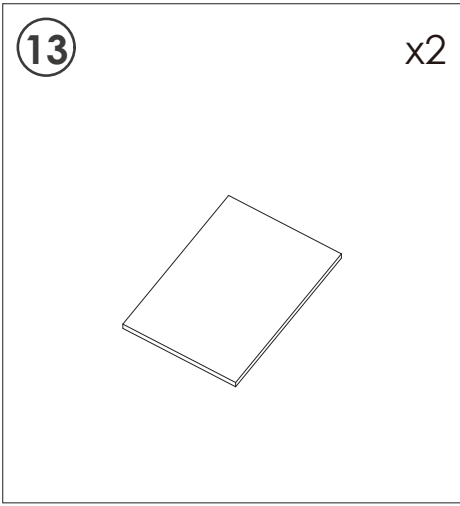

INSTALLATION INSTRUCTION

01

A x2pcs



M6*35mm

B x2pcs



M15*10mm

K x4pcs

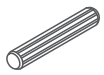

M6*40mm

Installation method of three
in one rod and buckle

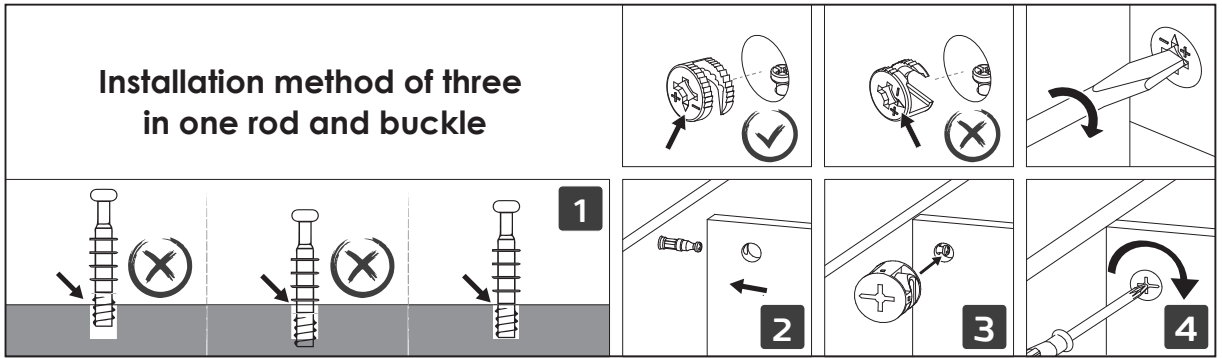

Correct panel numbering.

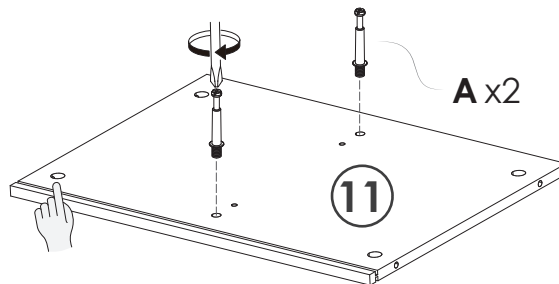
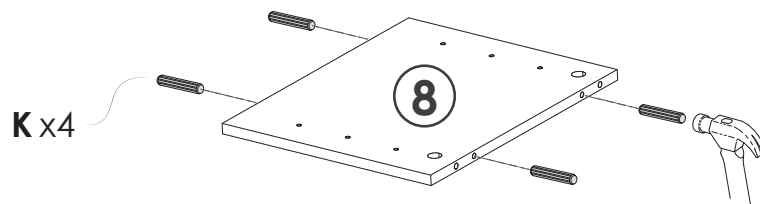

Note: The finger position
should be consistent
during installation.

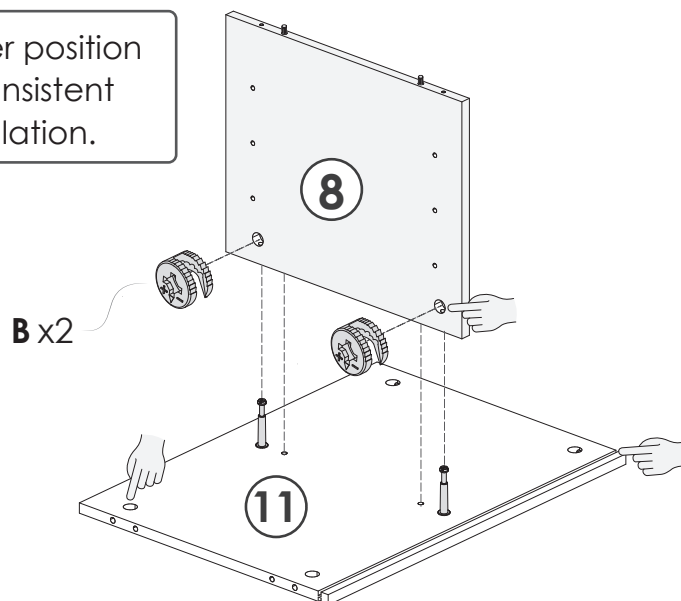

02

A x2pcs



M6*35mm

B x2pcs



M15*10mm

K x4pcs

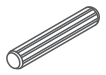

M6*40mm

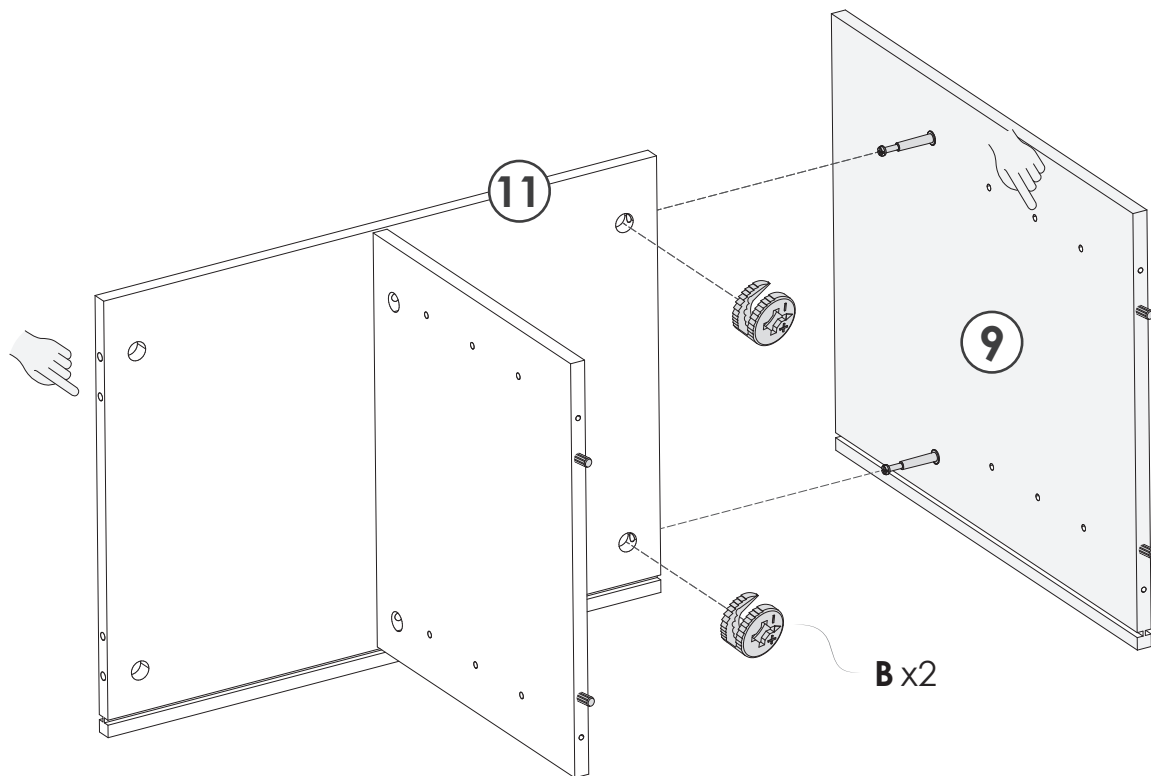
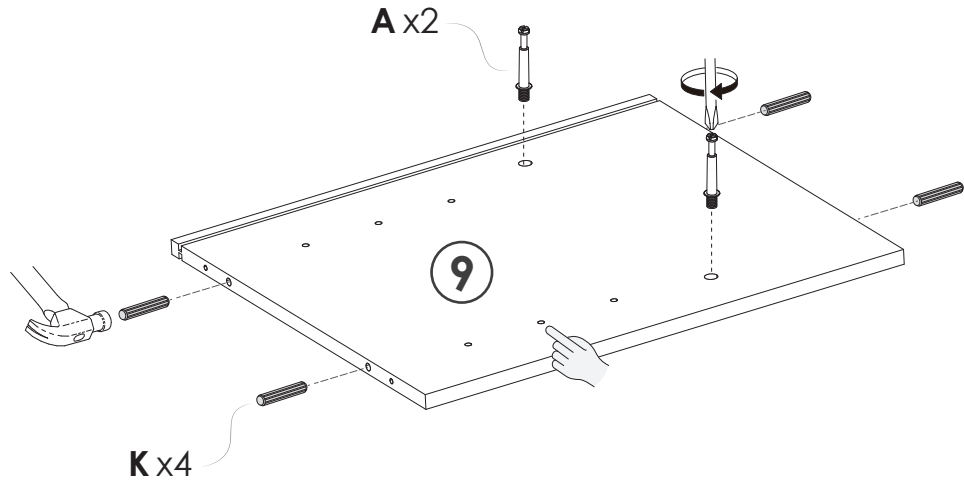

03

A x2pcs

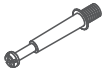

M6*35mm

B x2pcs



M15*10mm

K x4pcs

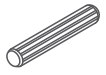

M6*40mm

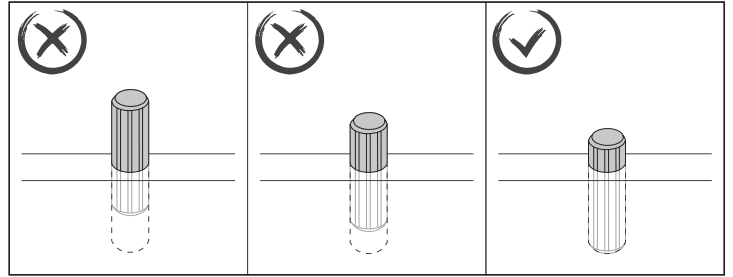
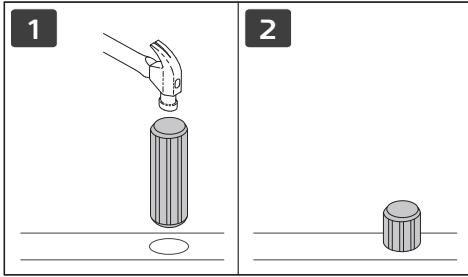

Correct panel numbering.

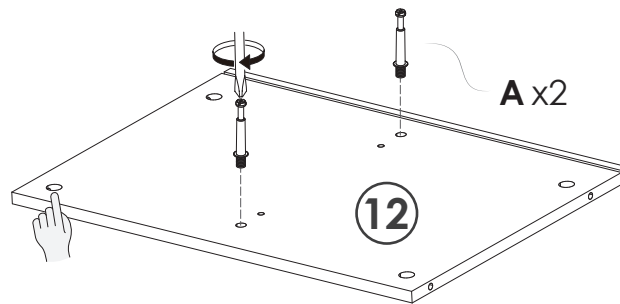
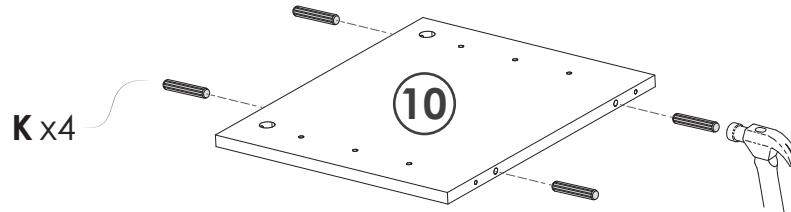

Note: The finger position should be consistent during installation.

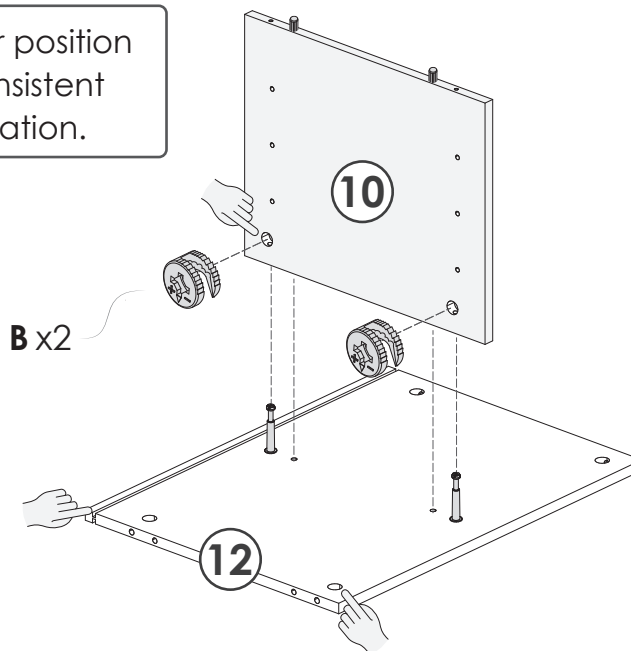

04

A x2pcs



M6*35mm

B x2pcs



M15*10mm

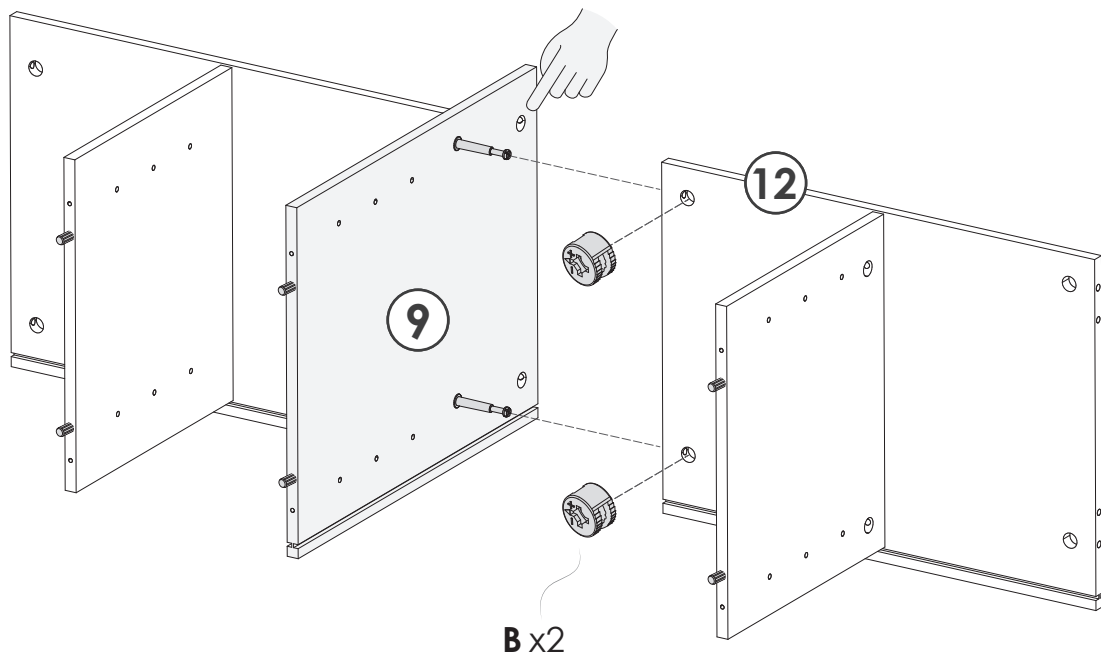
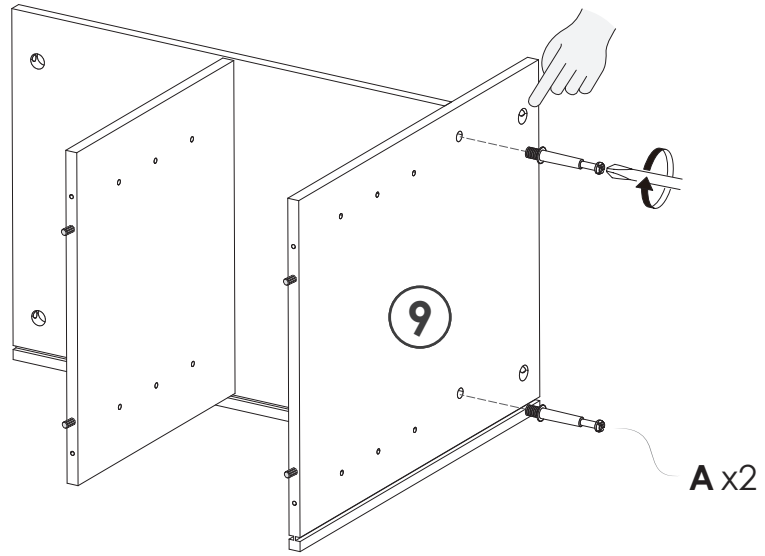

05

F x6pcs

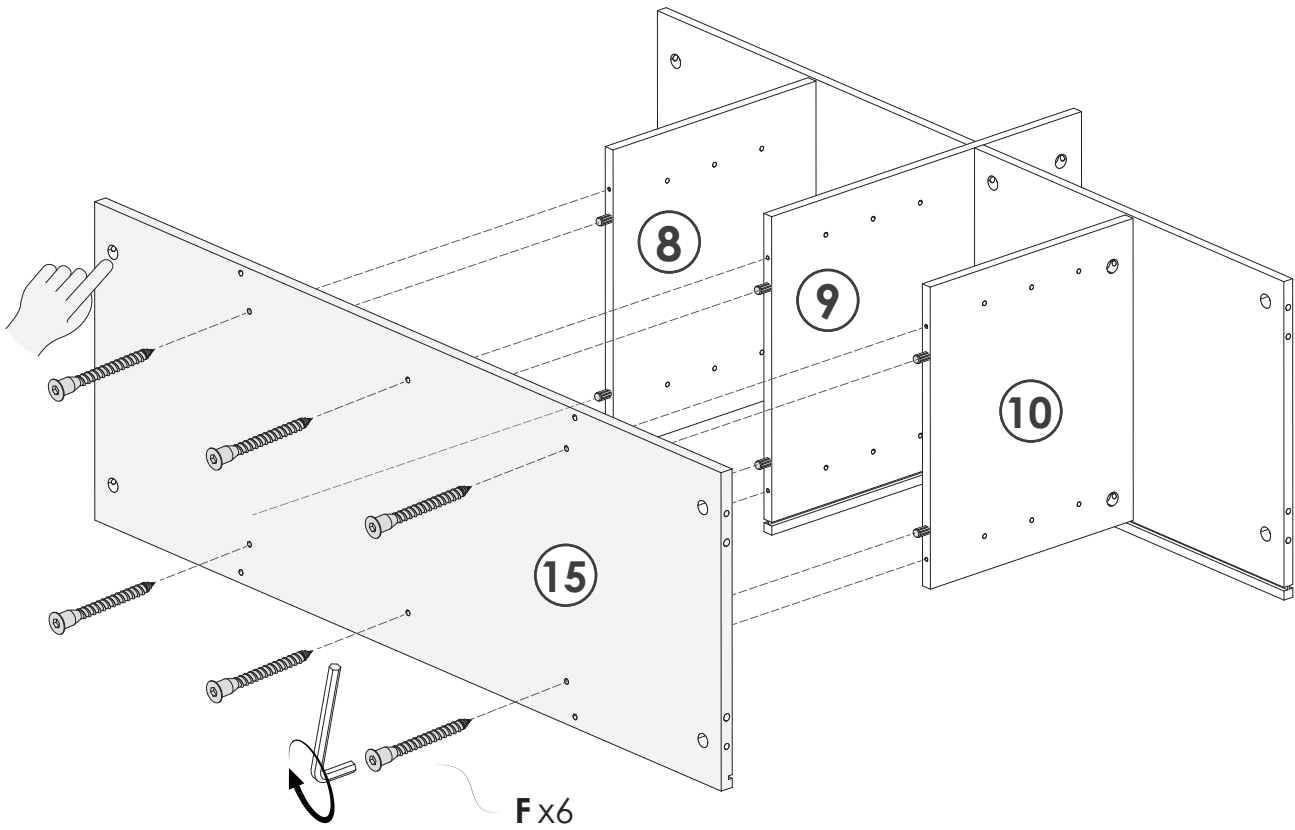
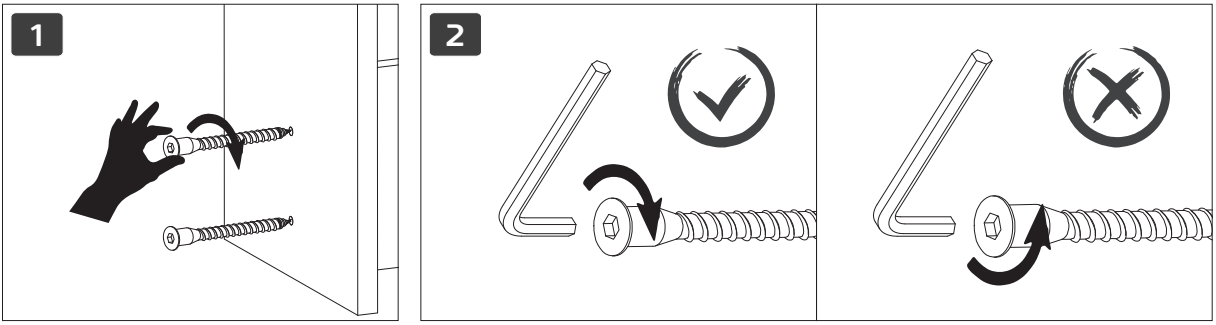

06

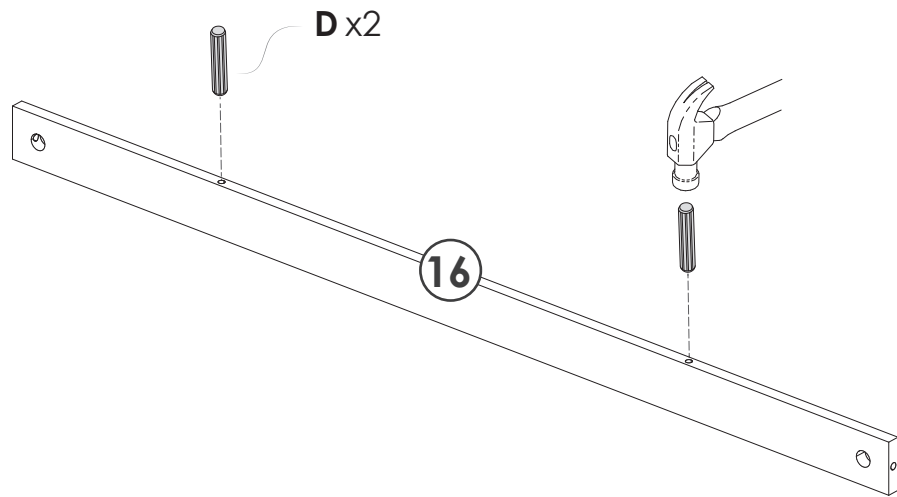
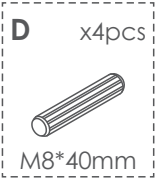

x2

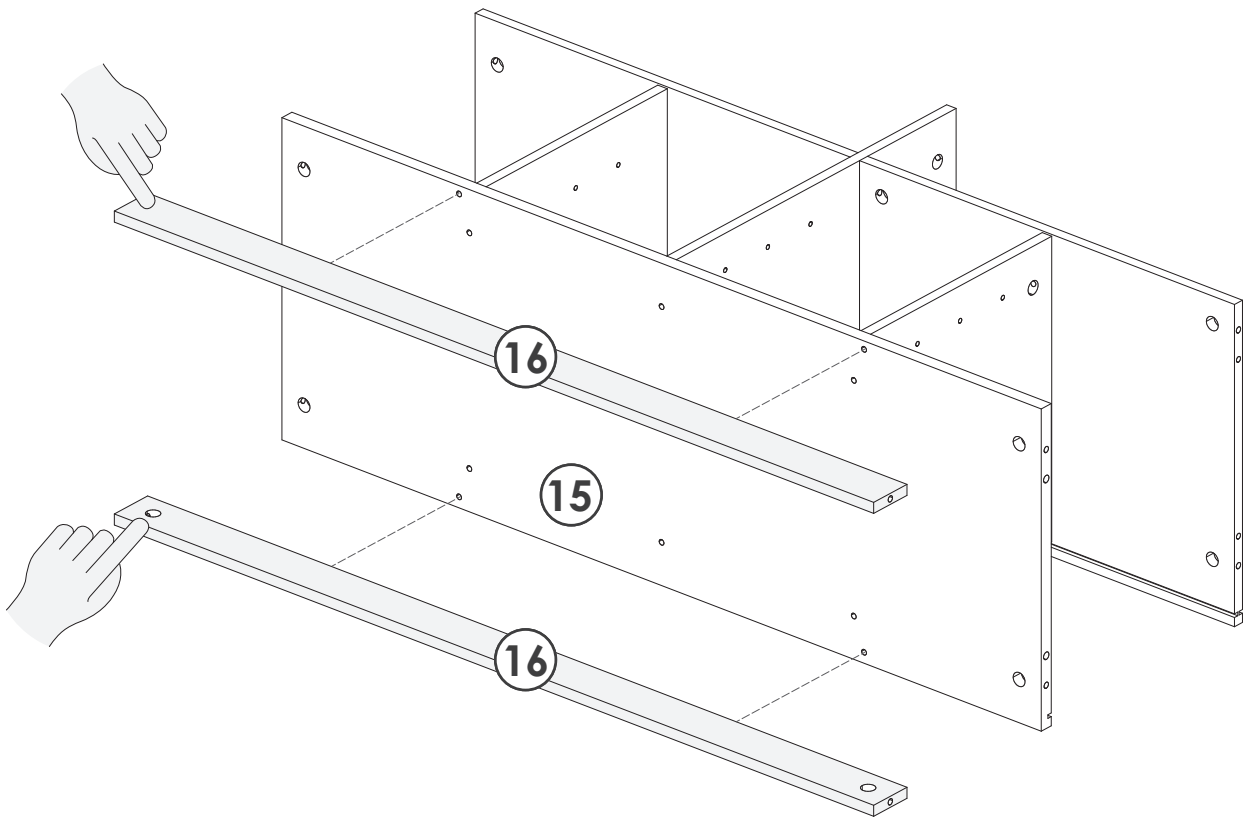

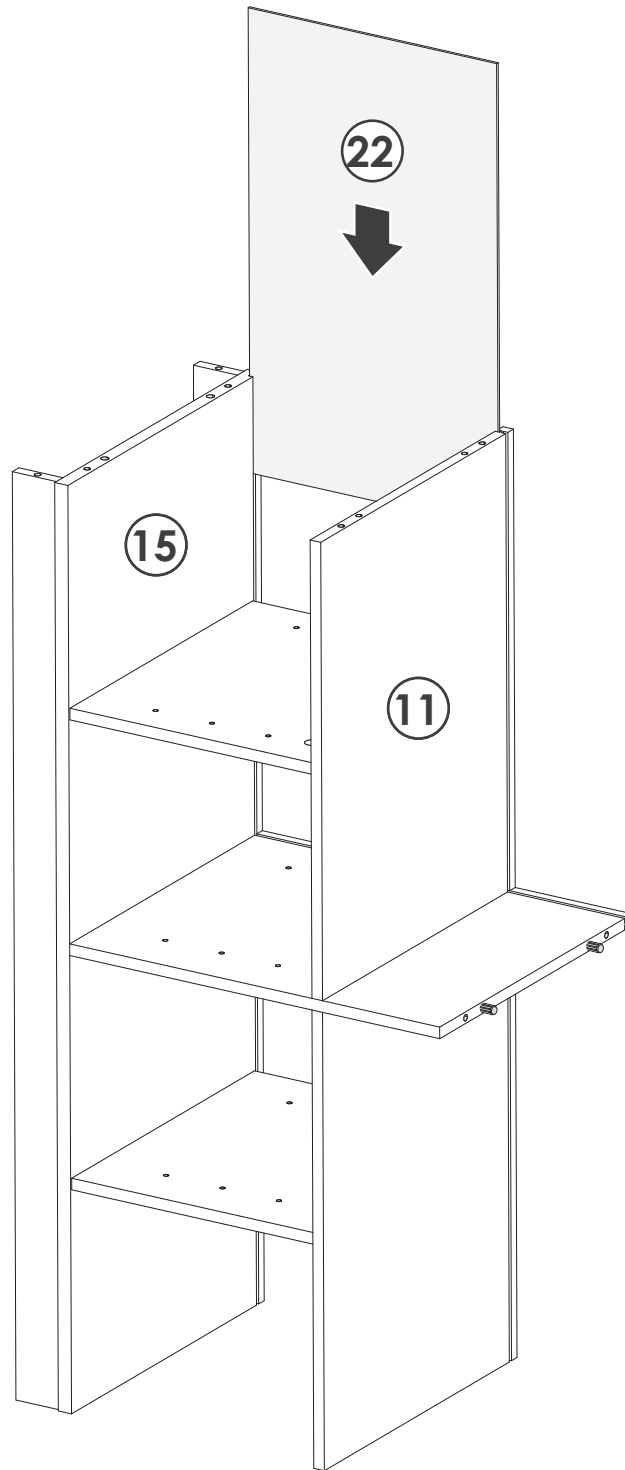

08

D x2pcs

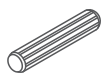

M8*40mm

K x2pcs

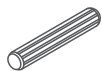

M6*40mm

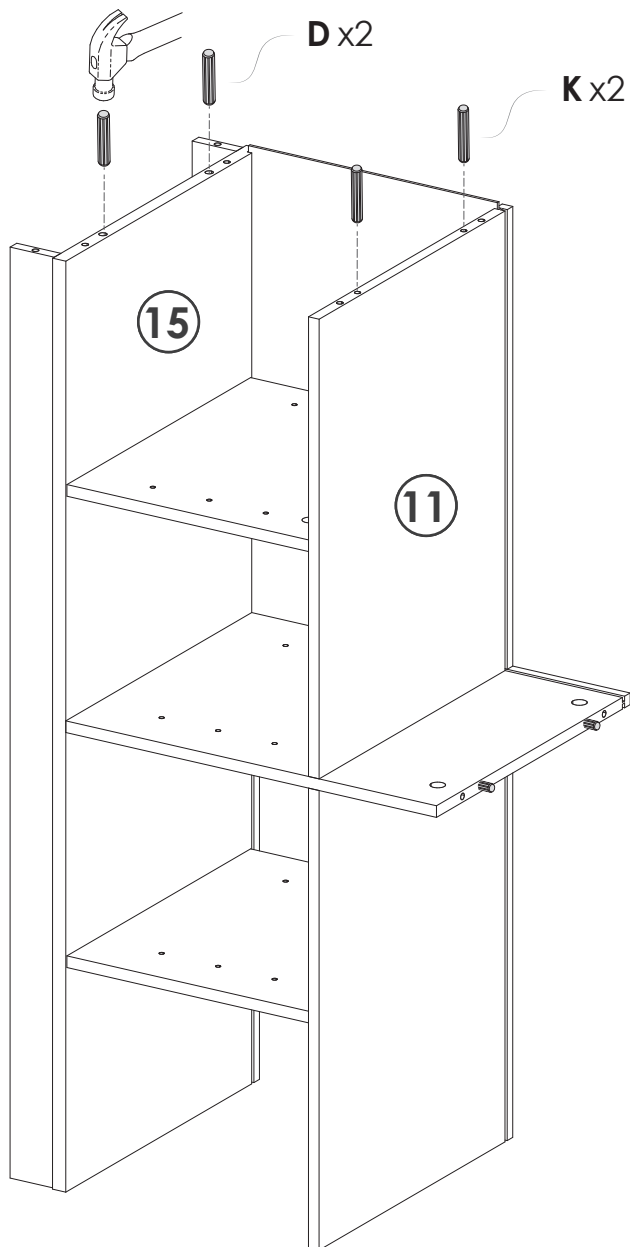

09

A x6pcs



M6*35mm

B x6pcs



M15*10mm

D x2pcs

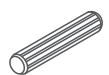

M8*40mm

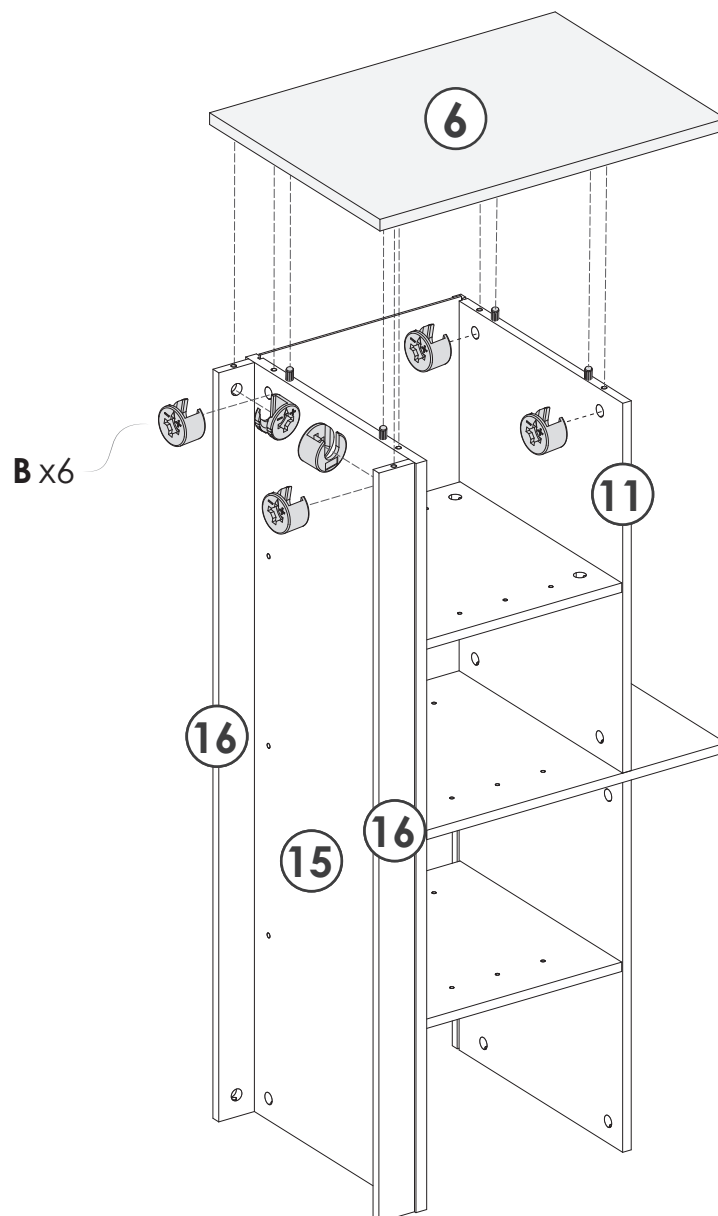
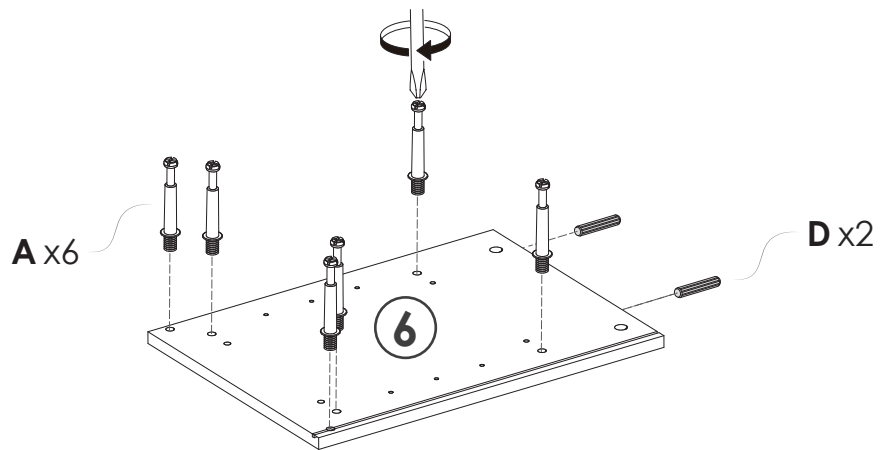

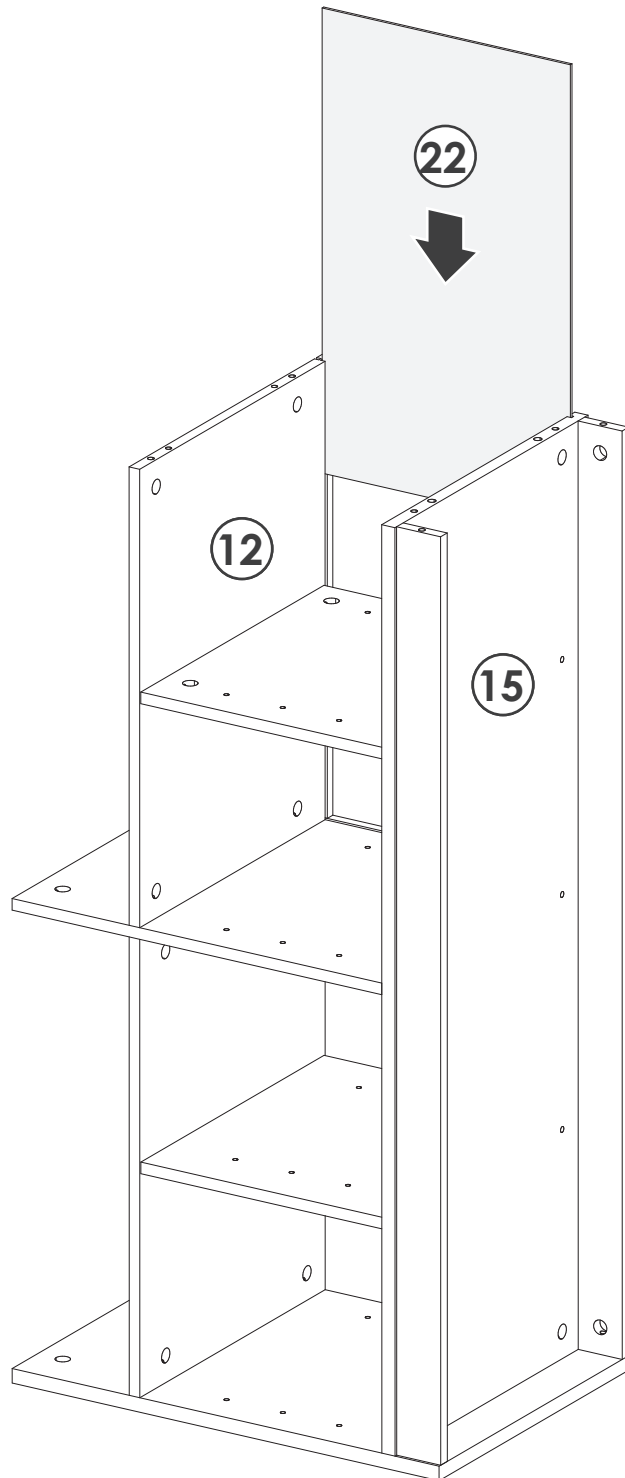

11

D x2pcs

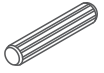

M8*40mm

K x2pcs

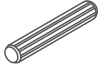

M6*40mm

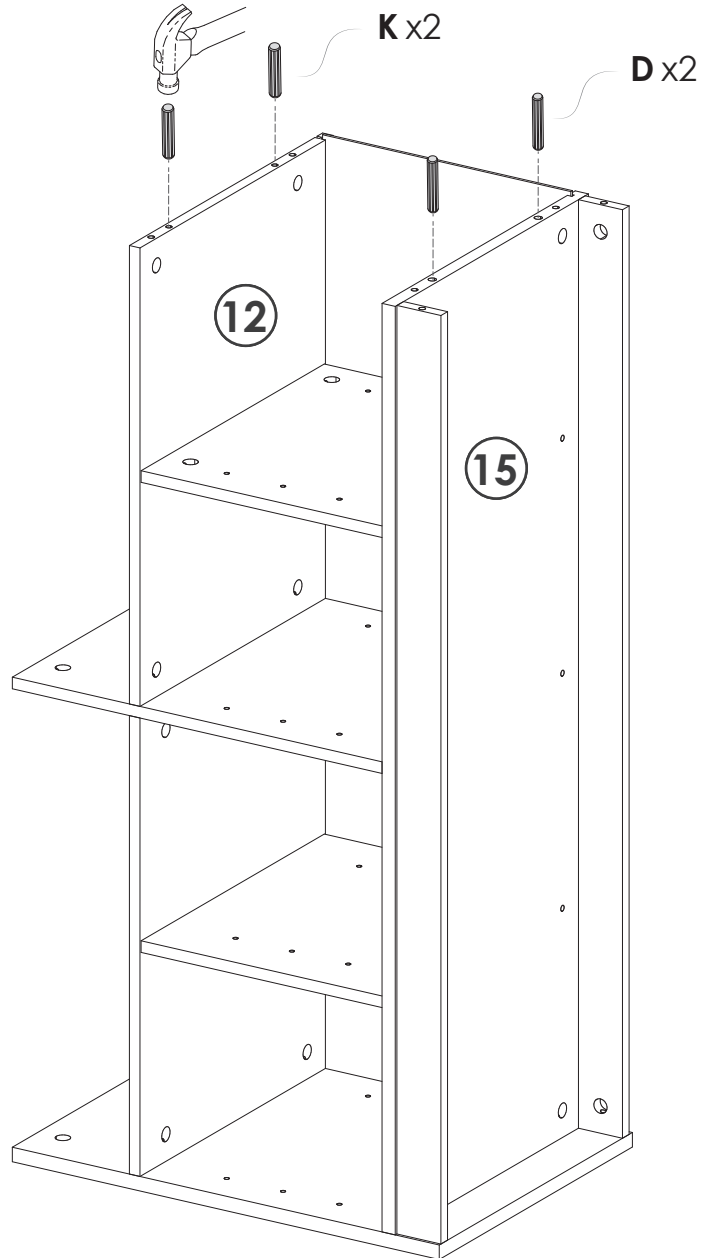

12

A x6pcs

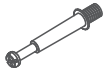

M6*35mm

B x6pcs



M15*10mm

D x2pcs

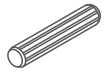

M8*40mm

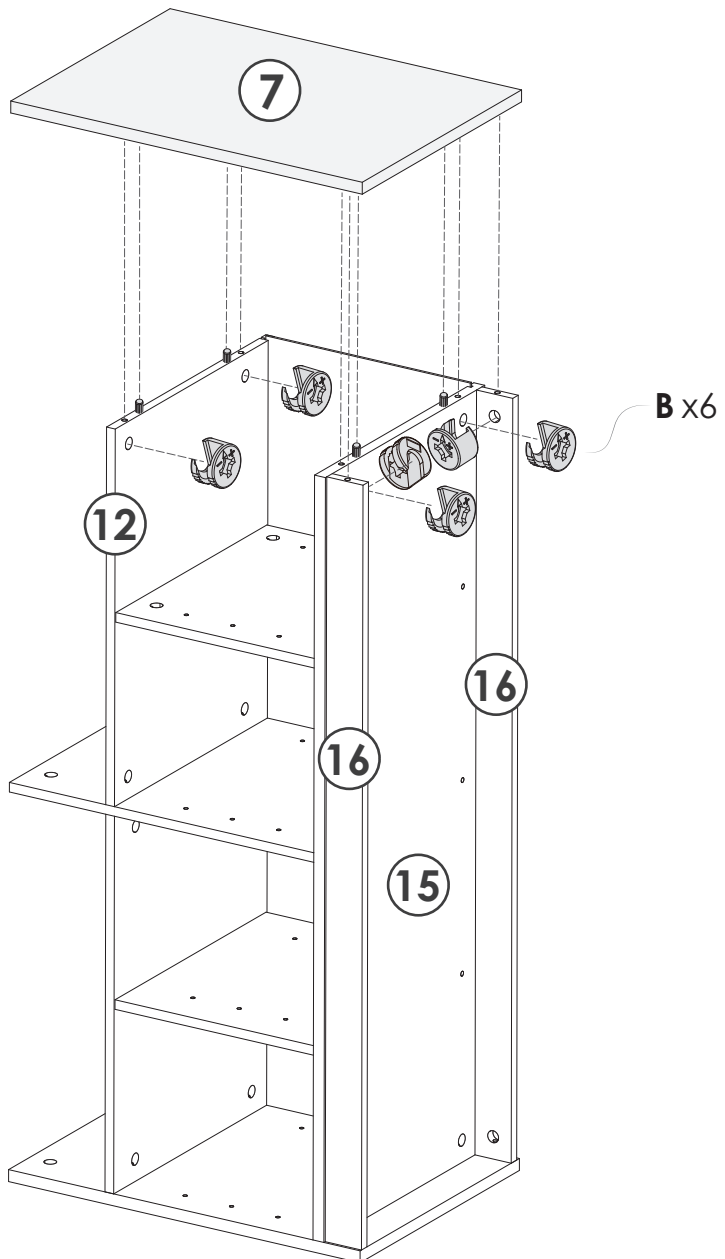
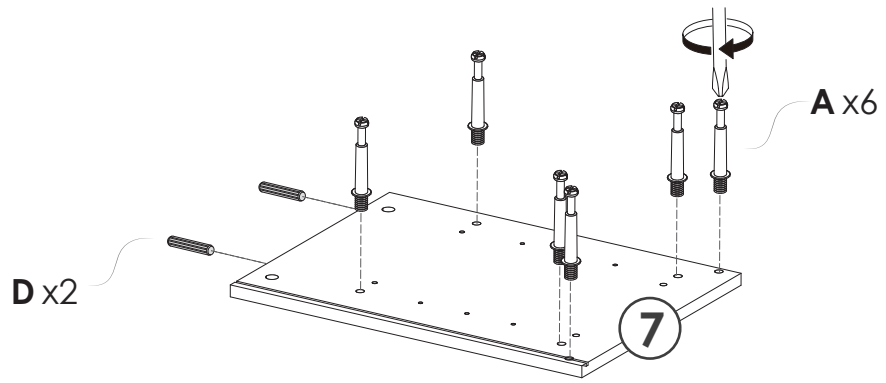

13

G x10pcs

Ø12*5mm

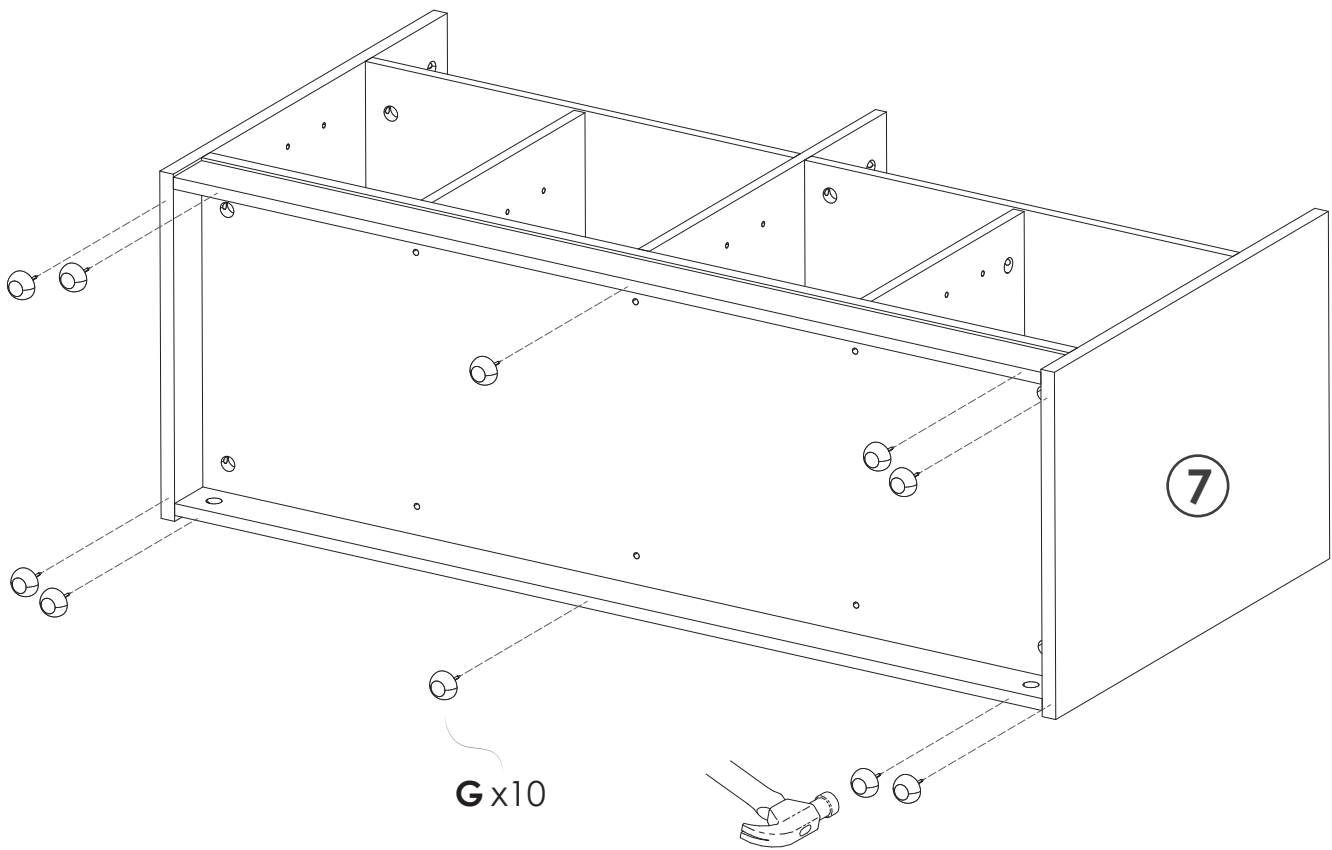
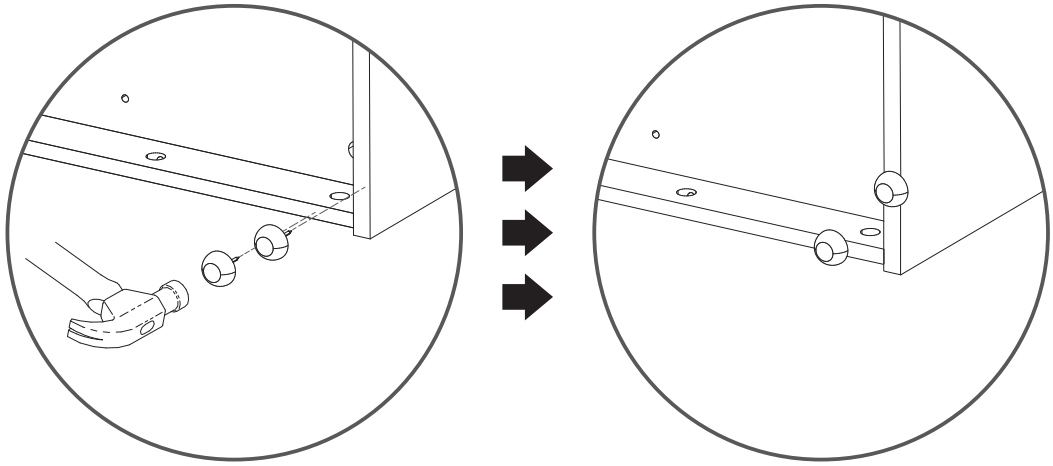

14

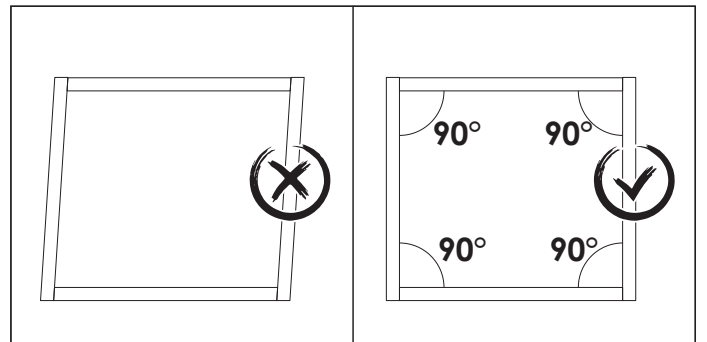
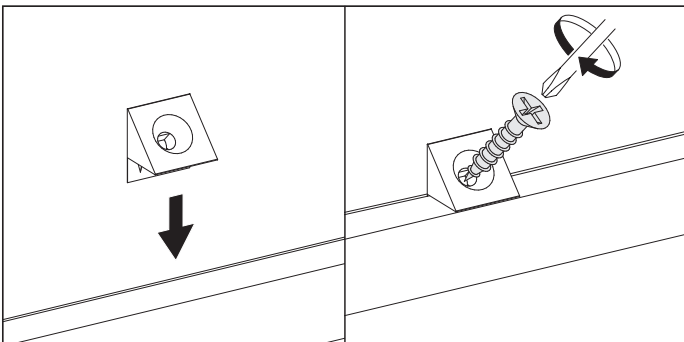
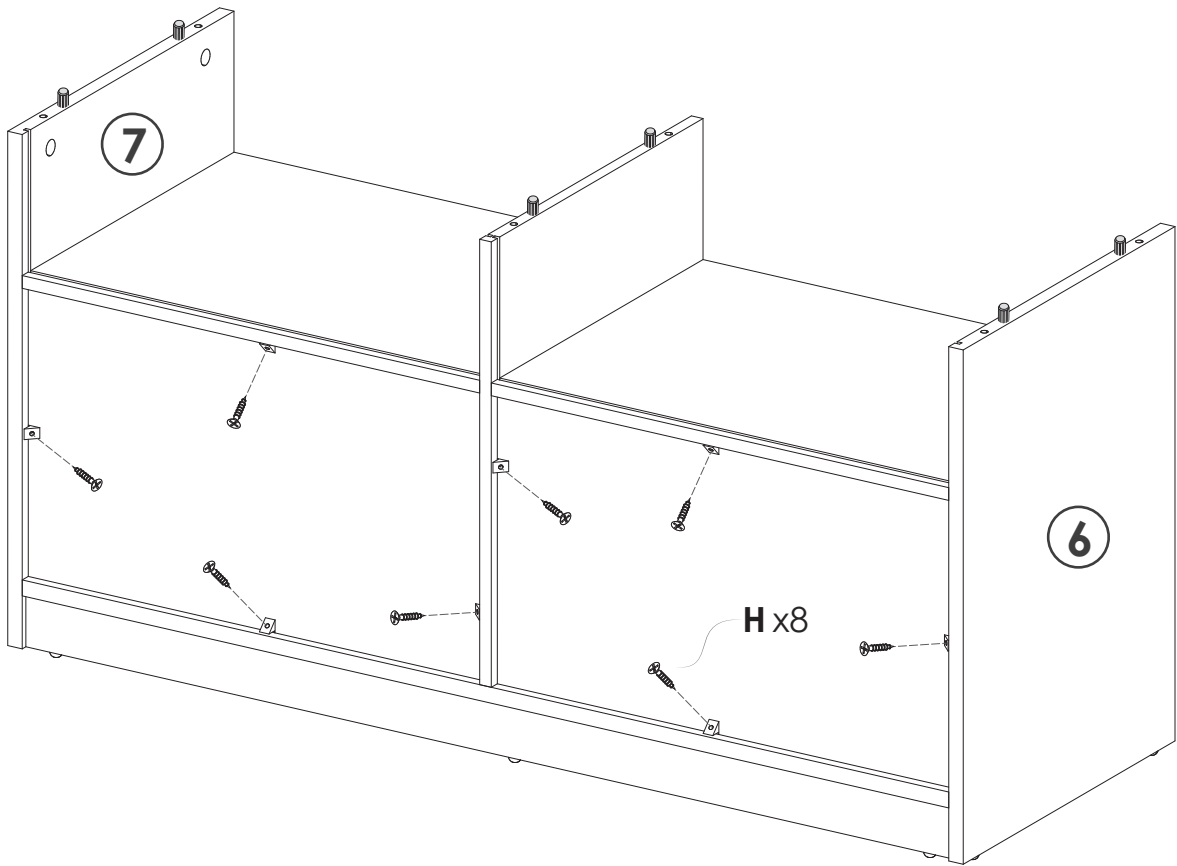
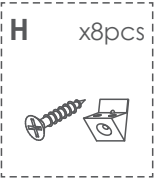

15

A x4pcs



M6*35mm

D x4pcs

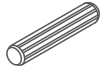

M8*40mm

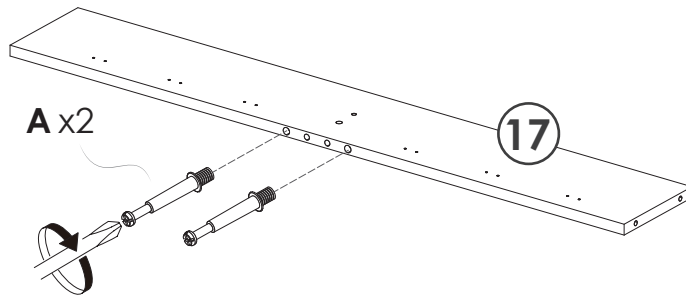

A x2

17

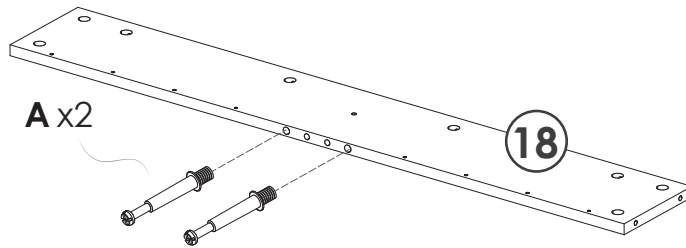

A x2

18

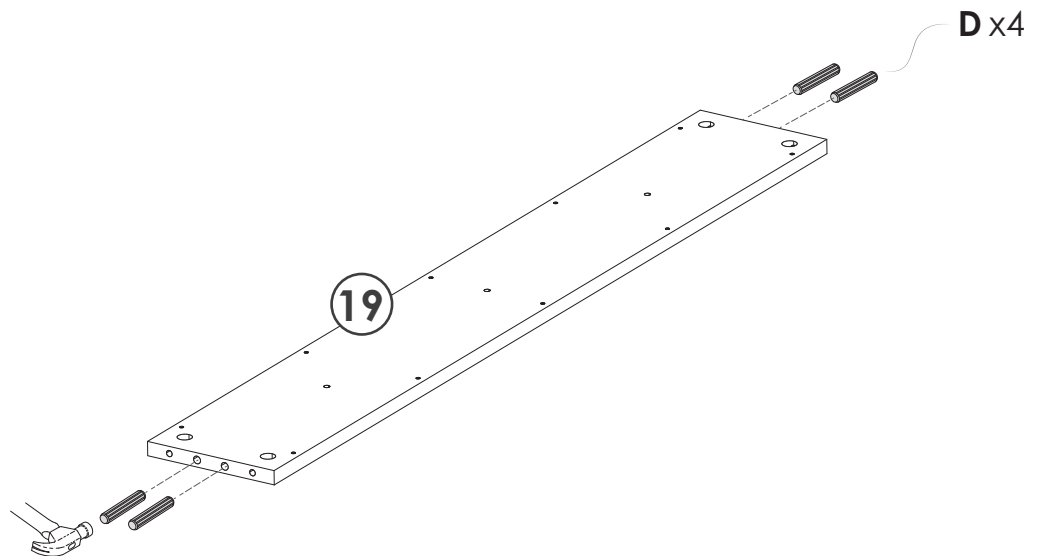

D x4

19

16

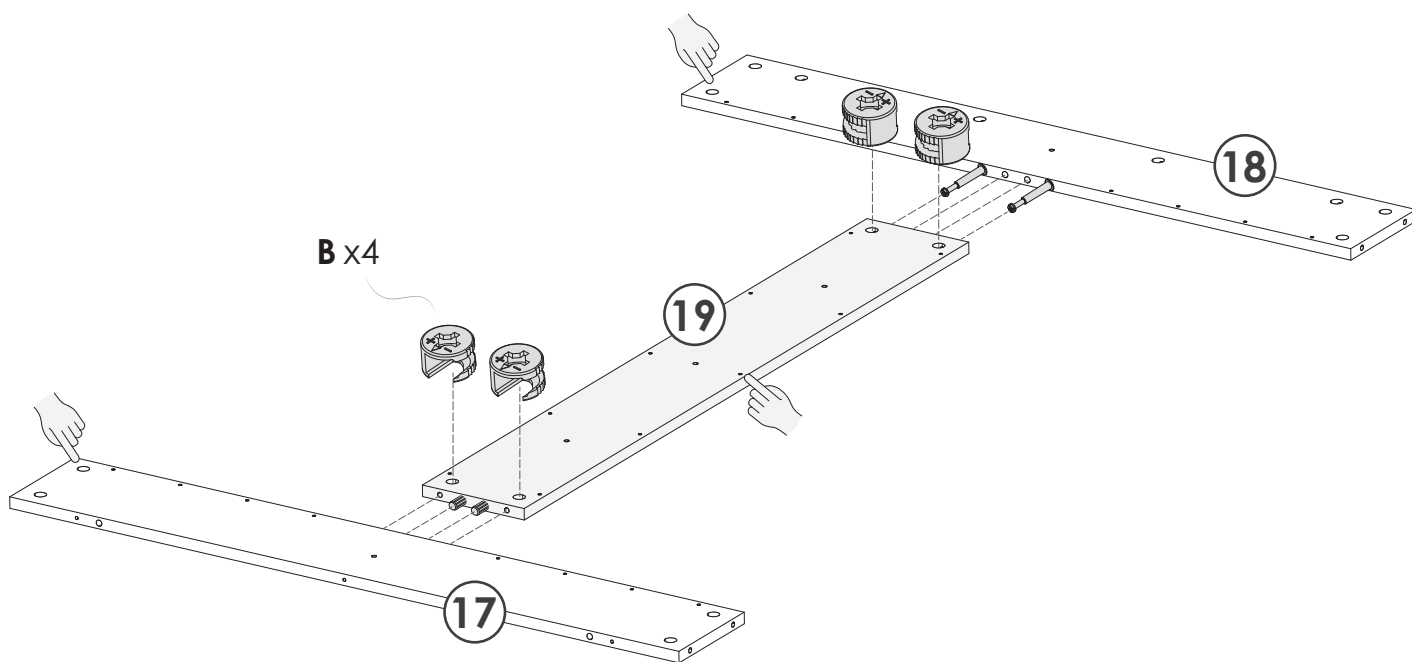
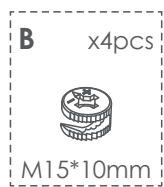

17

A x8pcs

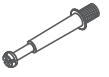

M6*35mm

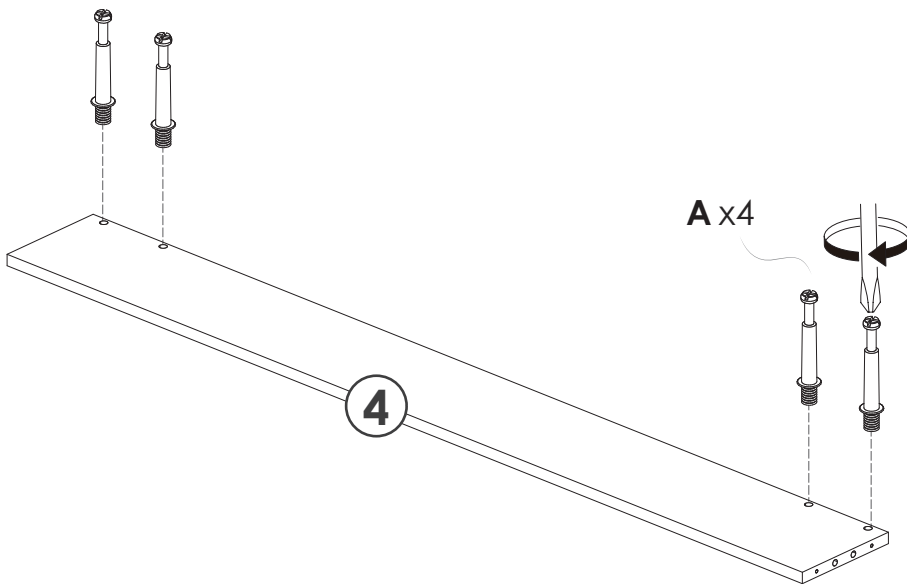
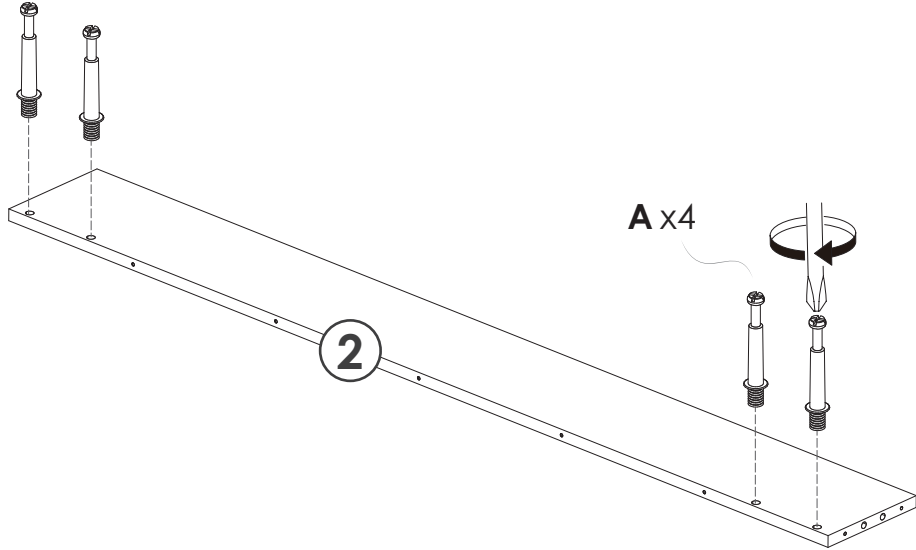

18

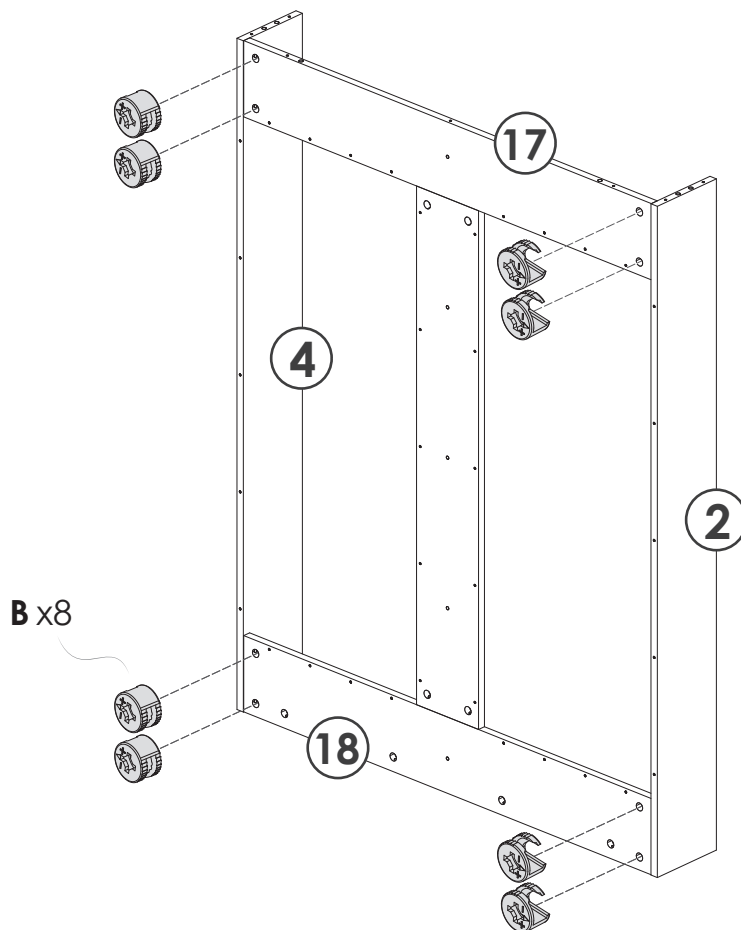
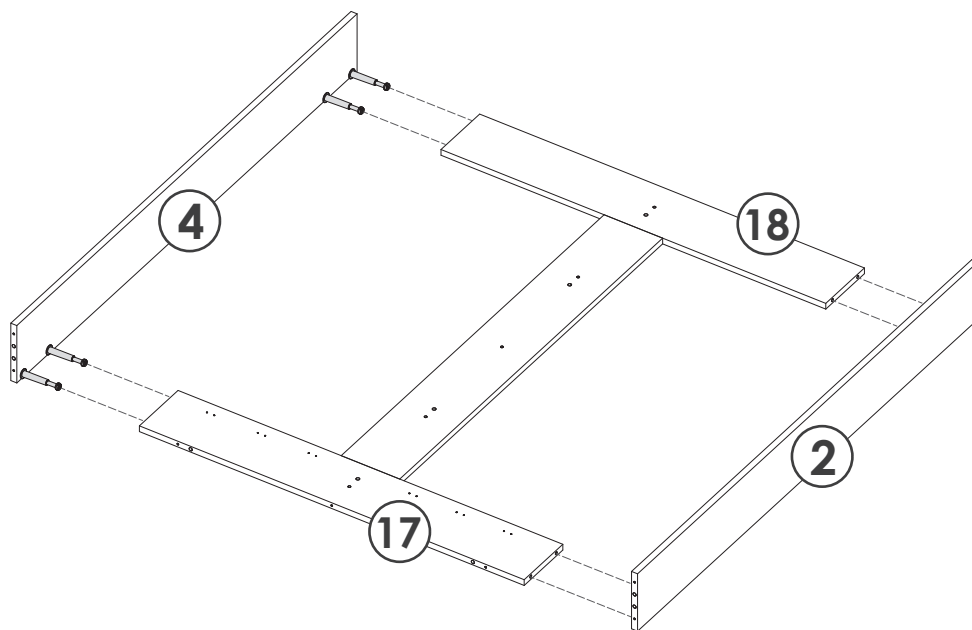
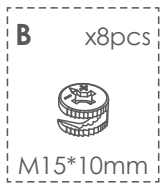

19

D x4pcs

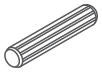

M8*40mm

F x5pcs



M5*40mm/#3

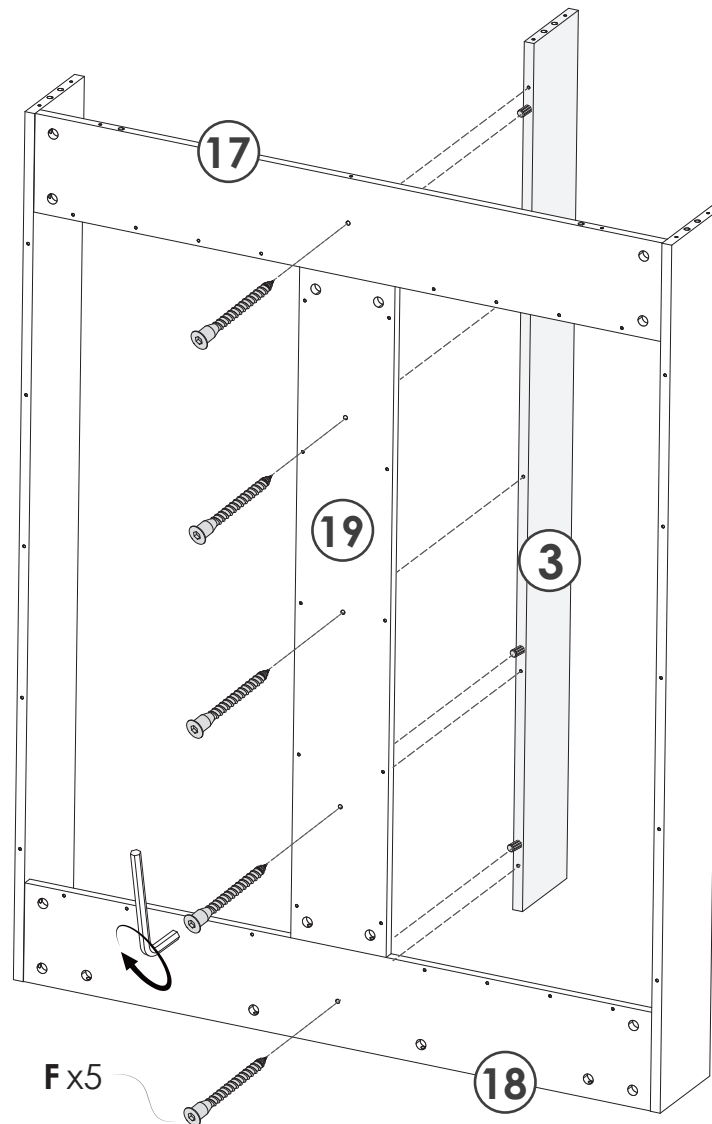
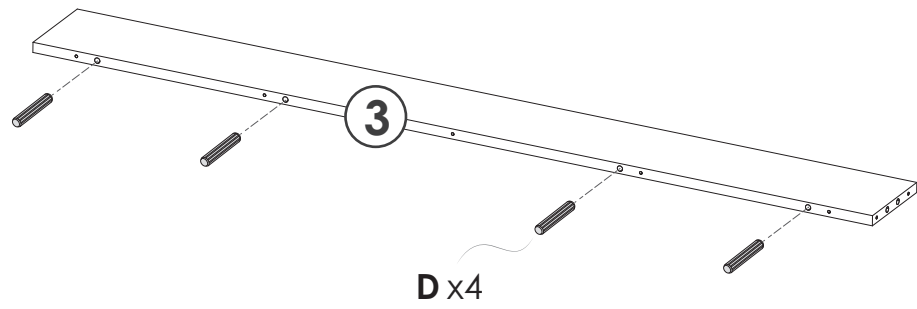

20

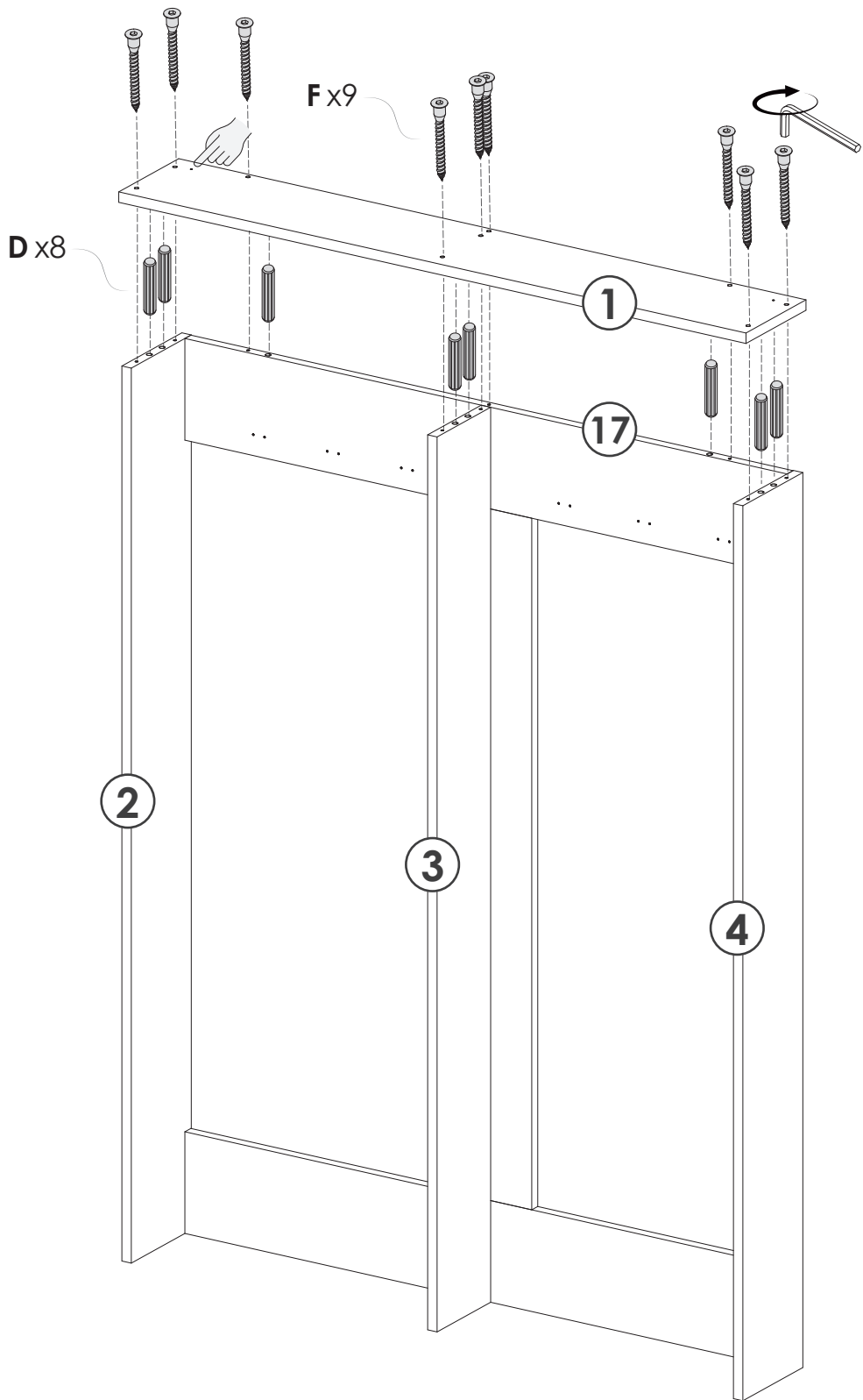
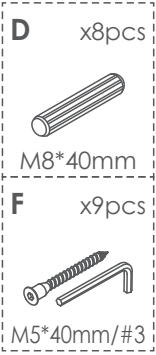

21

J x36pcs



M3.5*16mm

D x8pcs

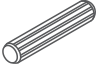

M8*40mm

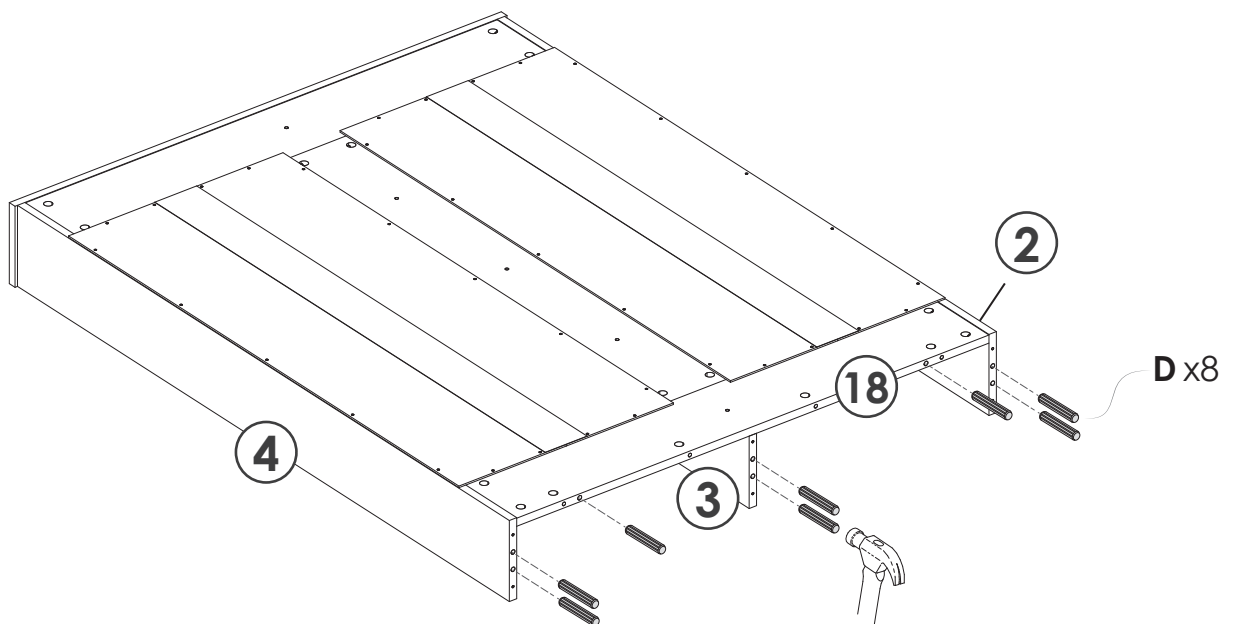
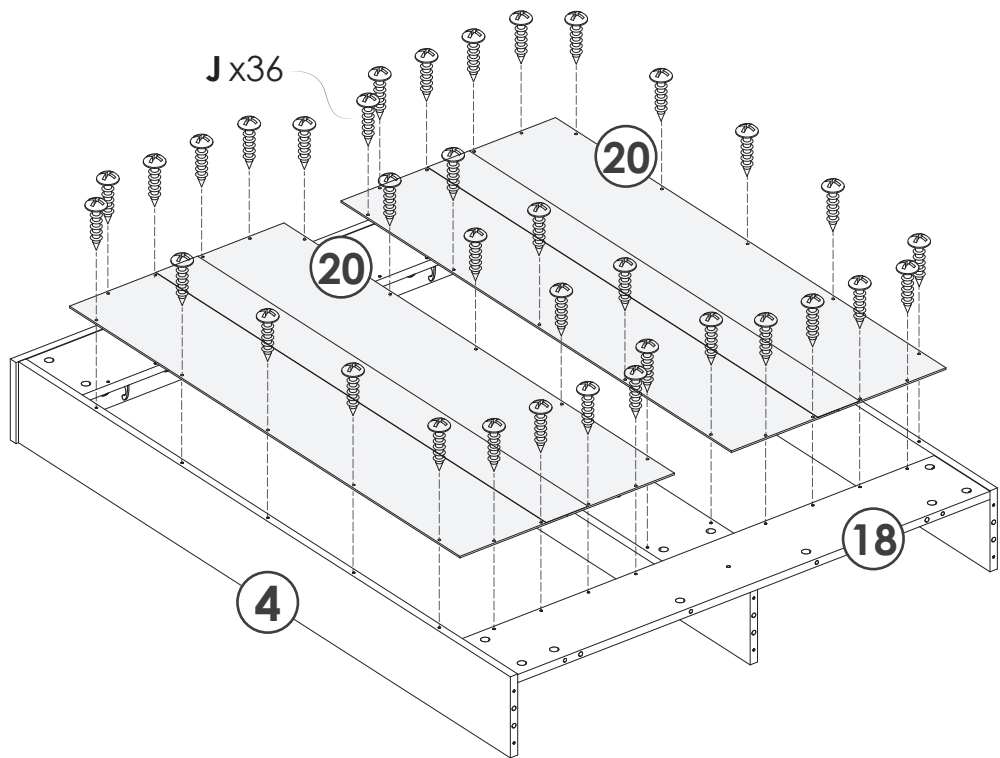

22

A x4pcs



M6*35mm

B x4pcs



M15*10mm

F x6pcs



M5*40mm/#3

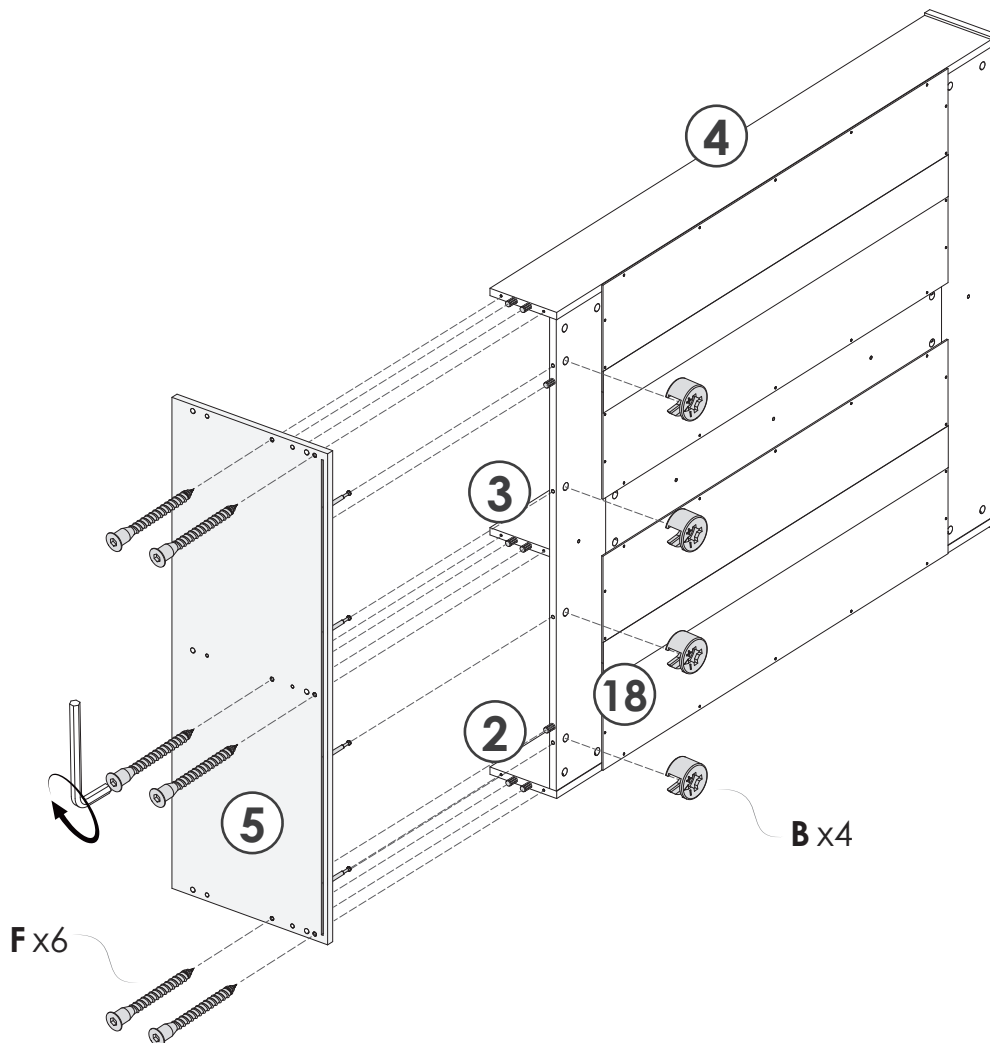
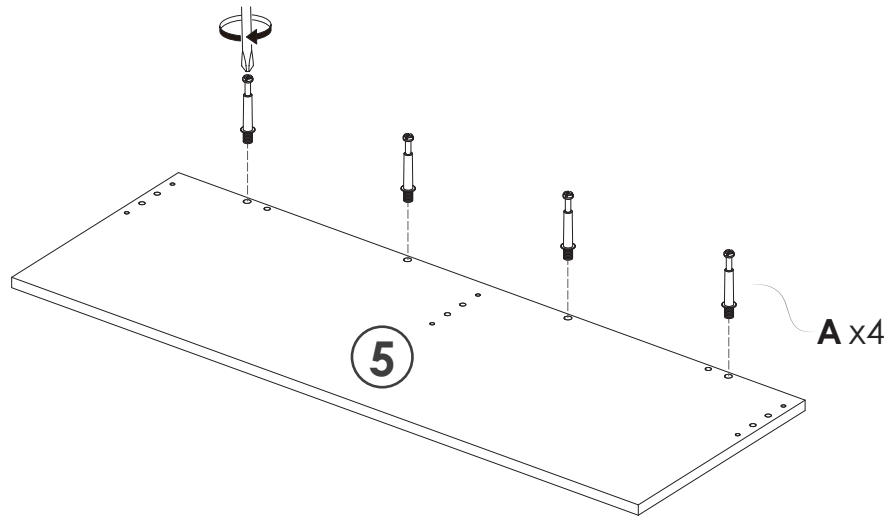

23

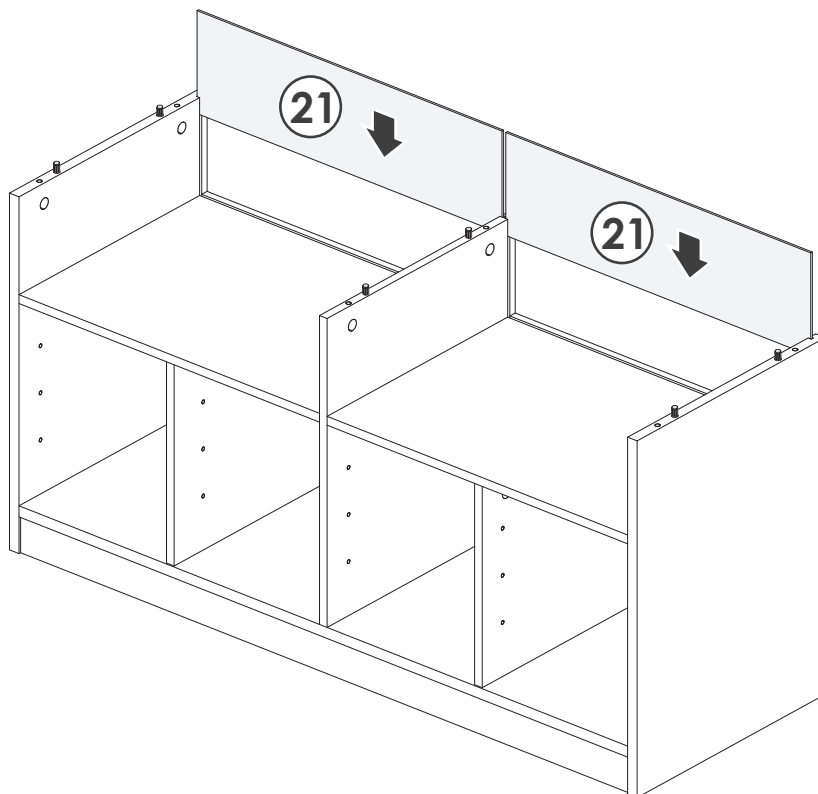
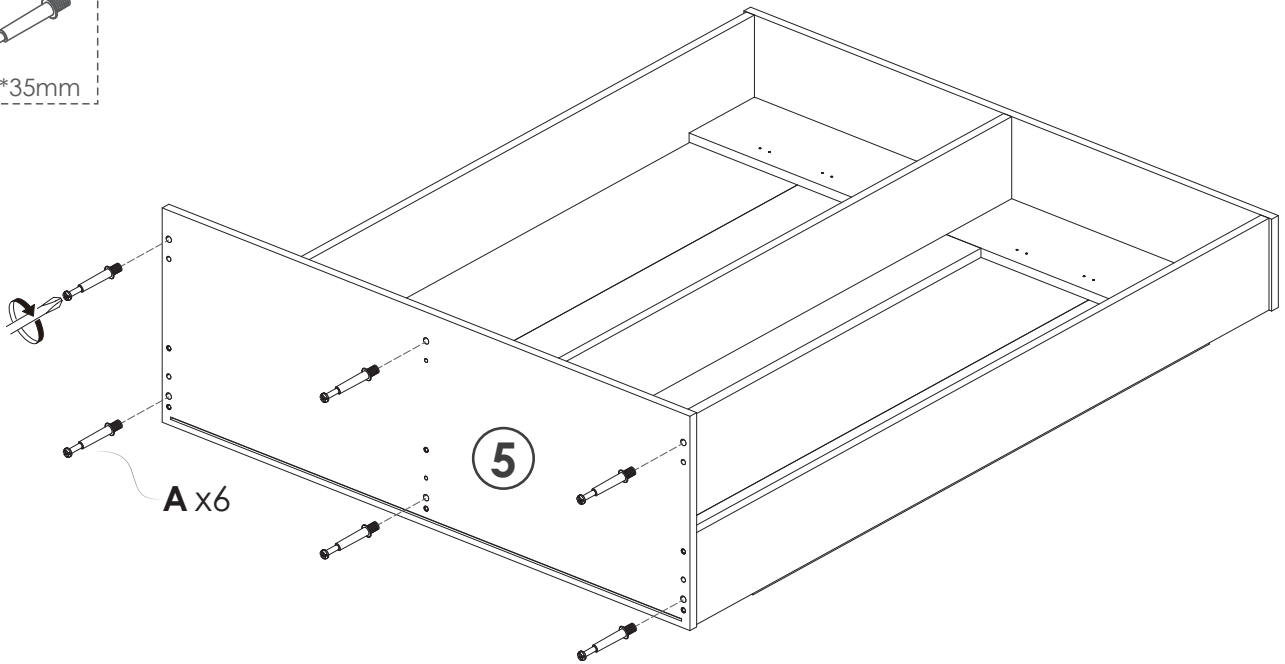
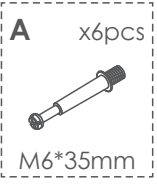

24

B x6pcs



M15*10mm

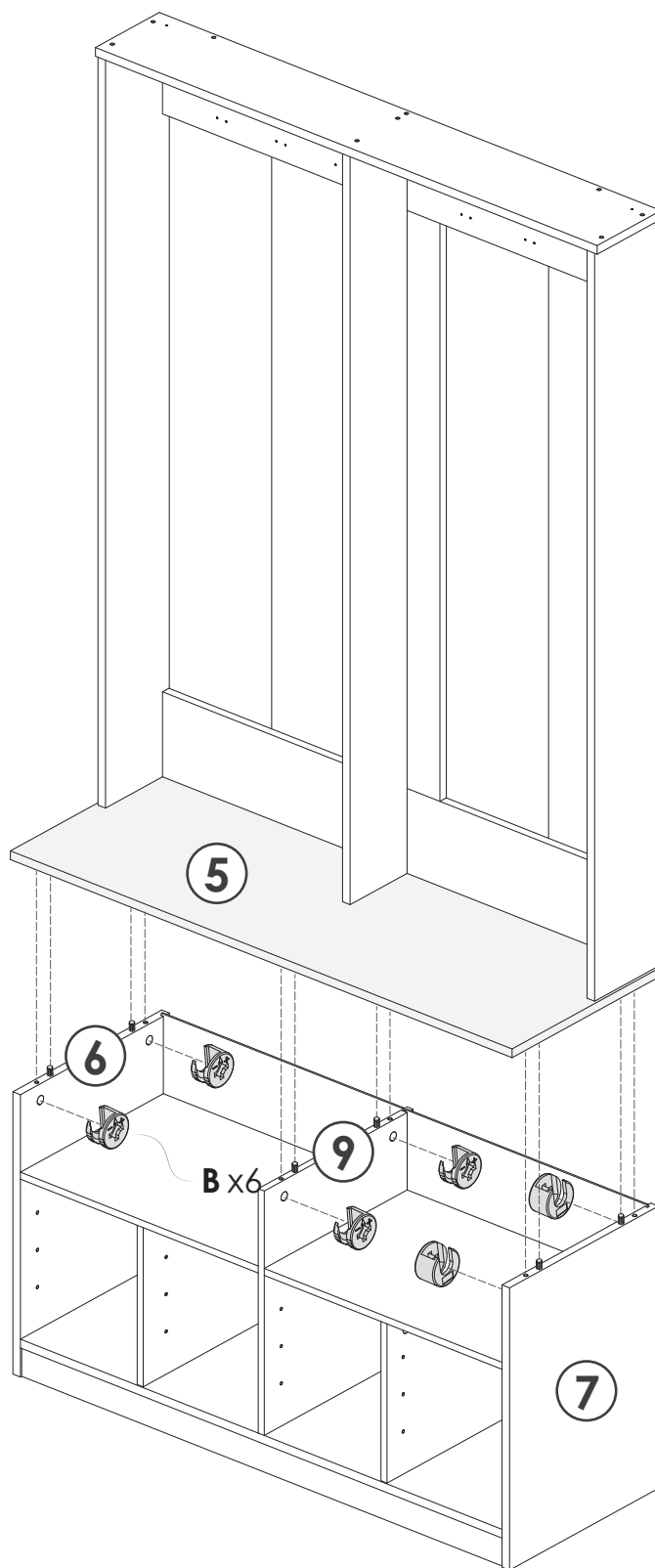

25

E x12pcs



M3.5*14mm

M x6pcs

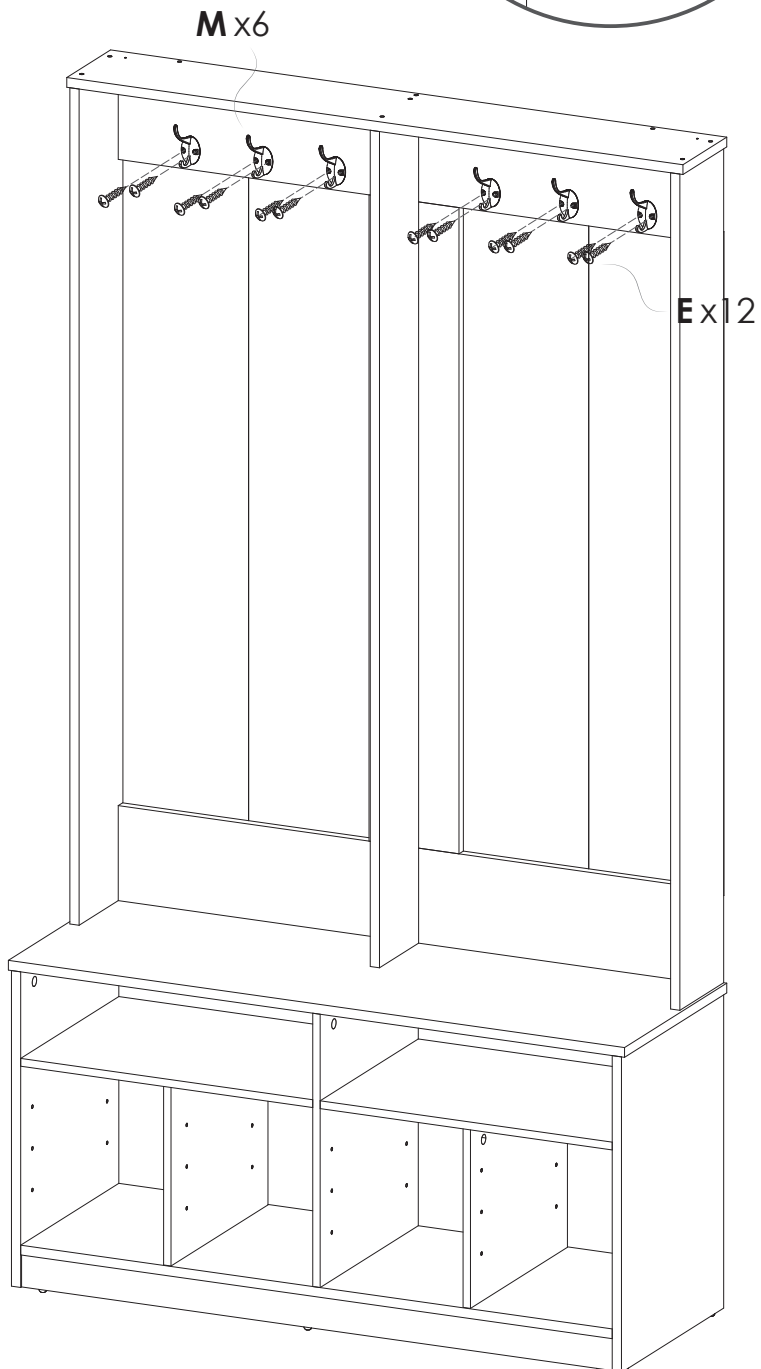
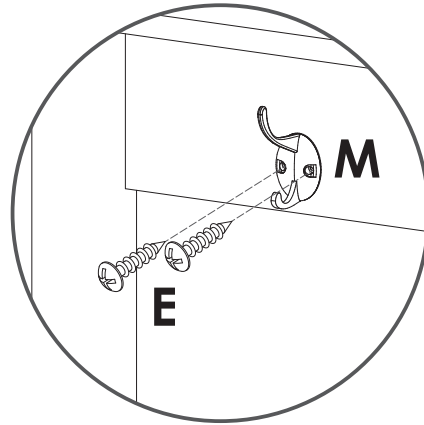

26

C x16pcs

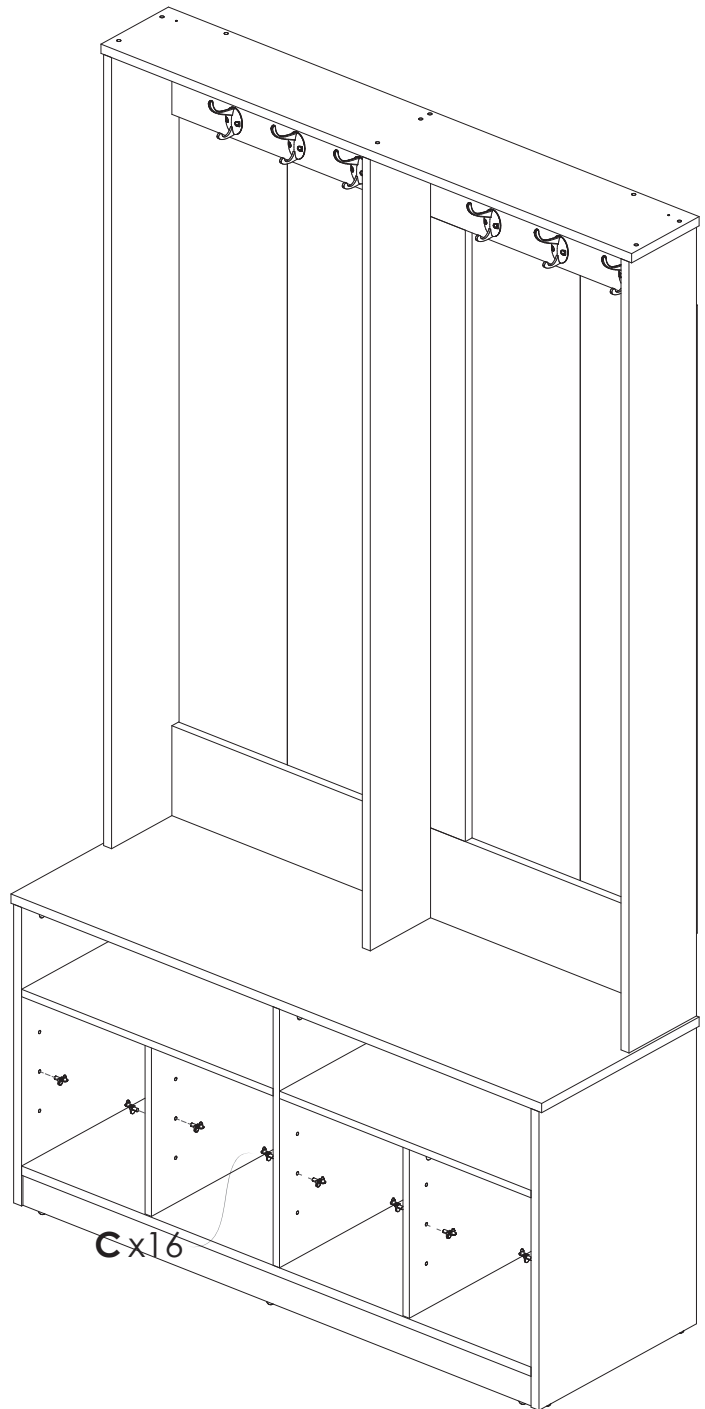
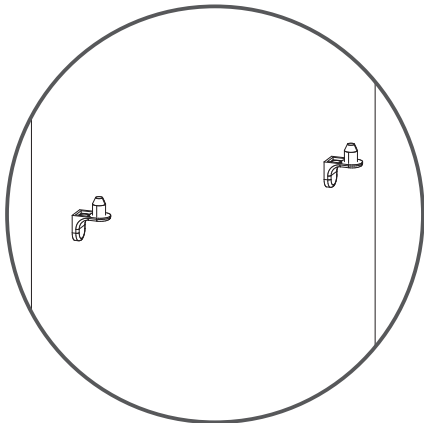
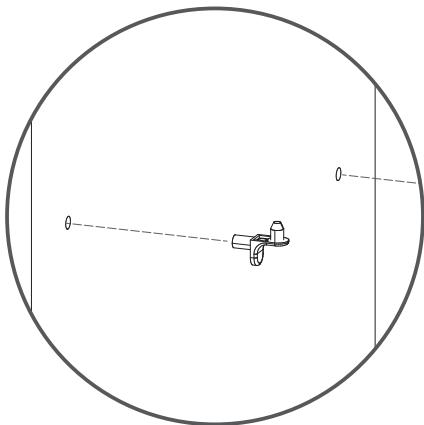

27

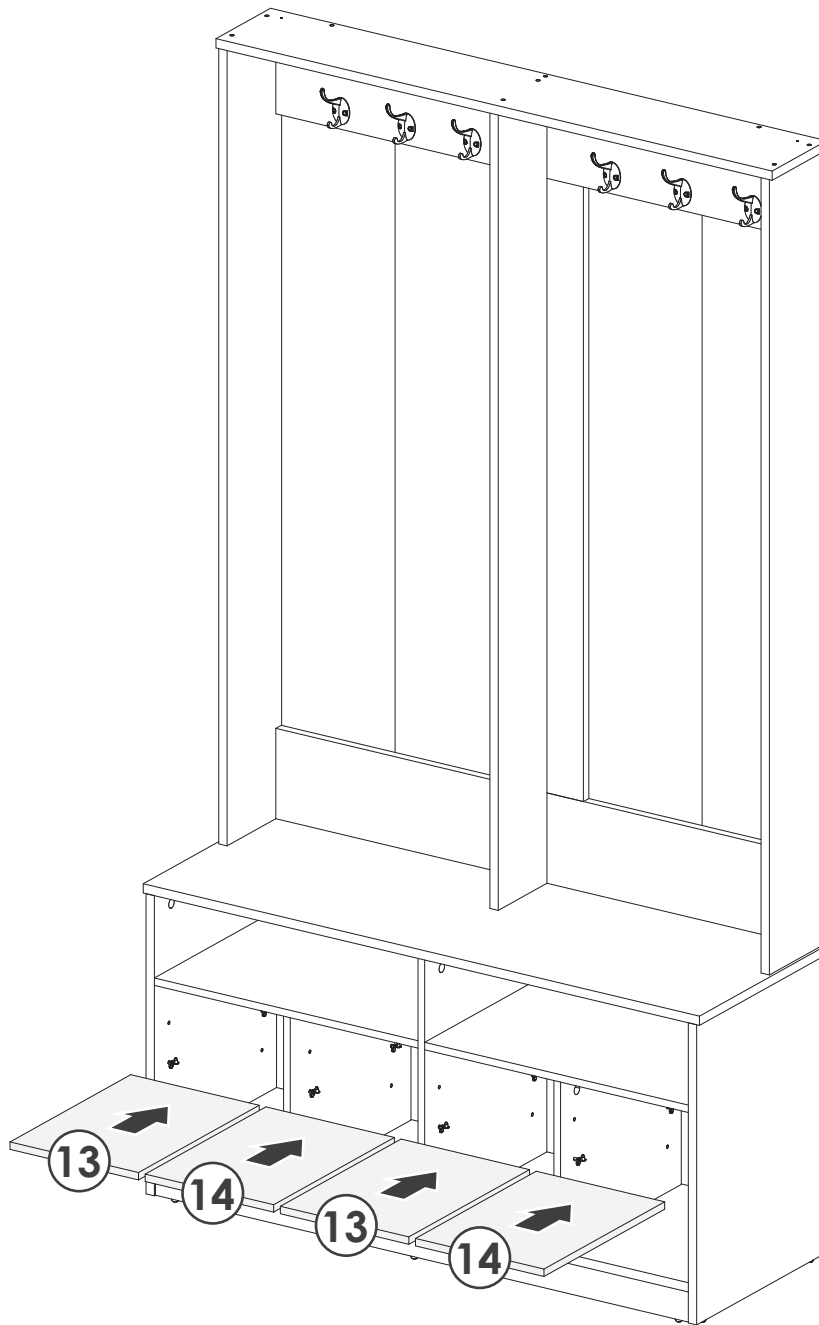
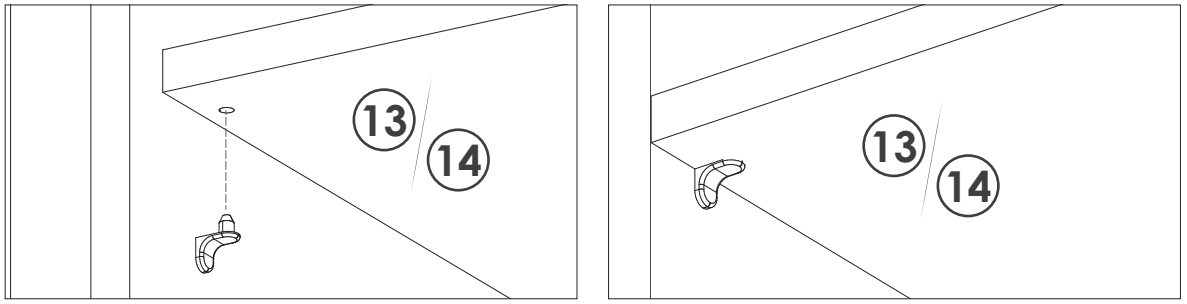

28

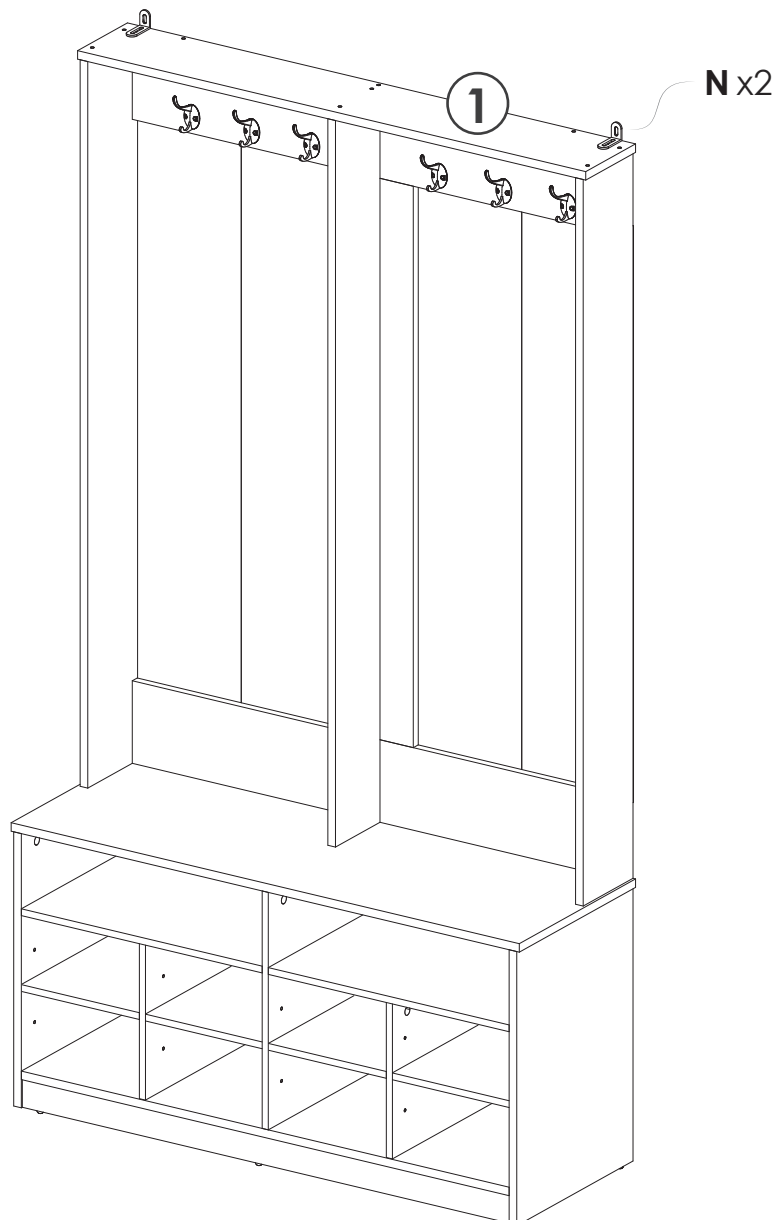
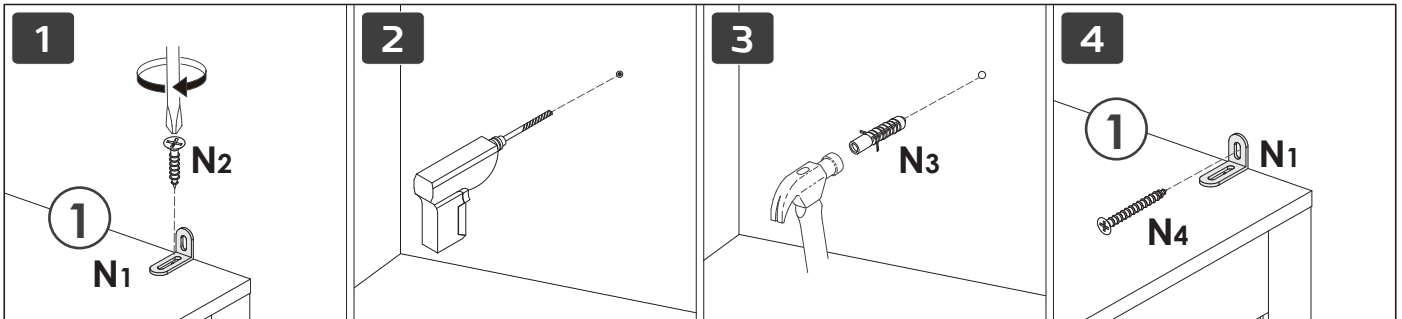
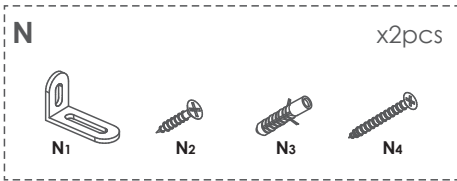

29

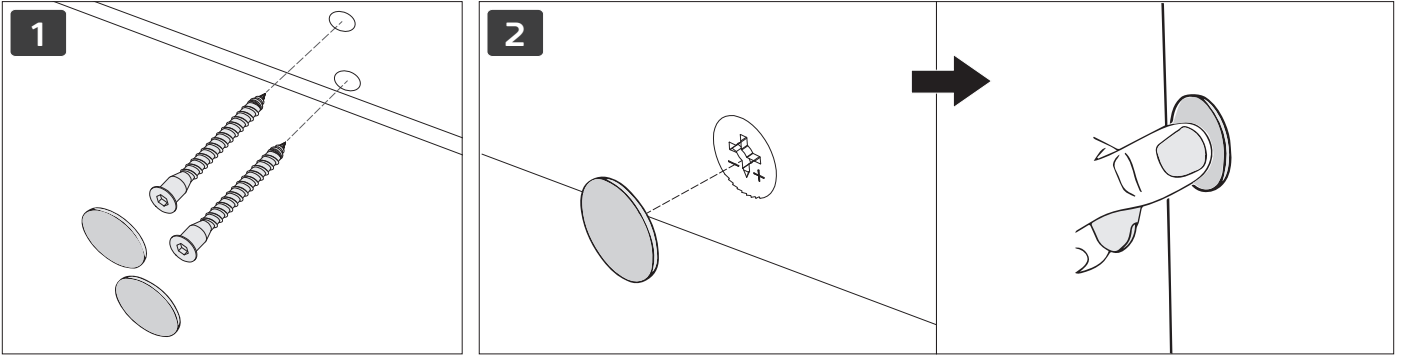

Add L fittings to all exposed holes on the front of the product

