

BED DRAWER SET OF 2

TWIN/FULL ASSEMBLY INSTRUCTIONS

Before assembling your bed drawer, please read through these instructions carefully, familiarize yourself with the different parts.

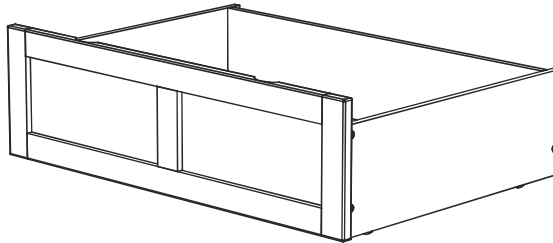
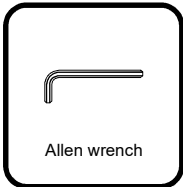

NOTE: WE INCLUDE SPARE HARDWARE IN CASE DAMAGE OCCURS DURING ASSEMBLY.

HARDWARE



(A) JCB M6 X 1" (25mm) - 16 pcs
Spare - 1 pc



(B) Wood Screw X 1 1/4" (32mm) - 4 pcs
Spare - 1 pc



(C) Allen wrench - 1 pc
Spare - 1 pc

PARTS LIST

- (01) HARDWARE 1 BOX**
- (02) DRAWER FACE 1 PC**
- (03) DRAWER SIDE 2 PCS**
- (04) DRAWER BACK 1 PC**
- (05) DRAWER BOTTOM 2 PCS**
- (06) DRAWER MIDDLE 1 PC**
- (07) DRAWER CENTER SUPPORT 1 PC**

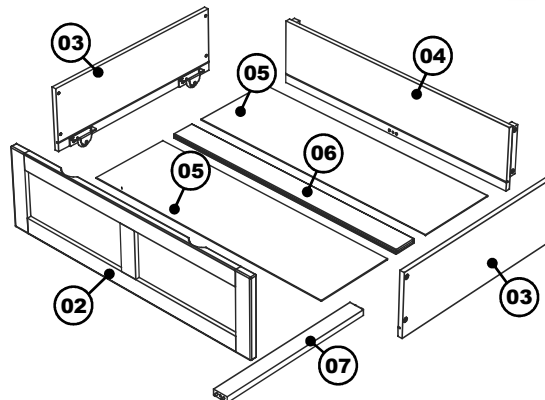

Step 1

Lay the drawer face (02) on smooth, flat surface so the drawer bottom (05) groove is facing upwards. Attach the drawer sides (03) to drawer face (02) using JCB M6 X 1" (A). Align groove inside drawer side with groove in drawer face. Tighten with Allen wrench (C).

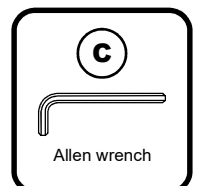
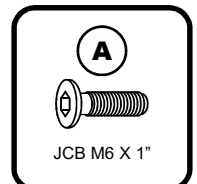
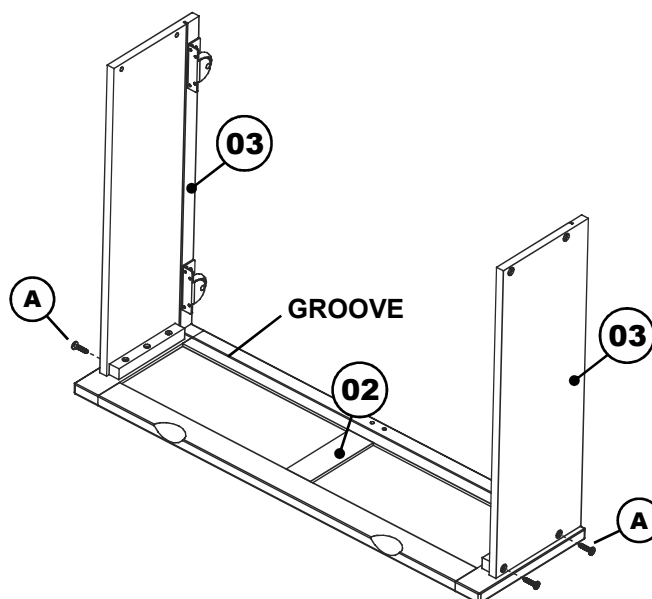

BED DRAWER SET OF 2

TWIN/FULL

Step 2

Guide the drawer bottoms (05) and drawer middle (06) in carefully so that they align inside grooves. Be sure it fits fully into the face and side groove before attaching the drawer back (04).

Attach drawer center support (07) to bottom of drawer face using wood screw 1 1/4" (B). Tighten with Phillips head screw driver. (Customer supplied)

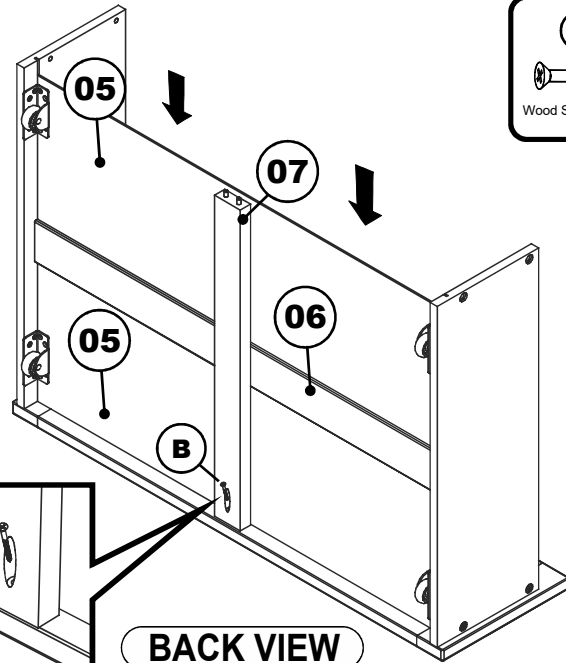
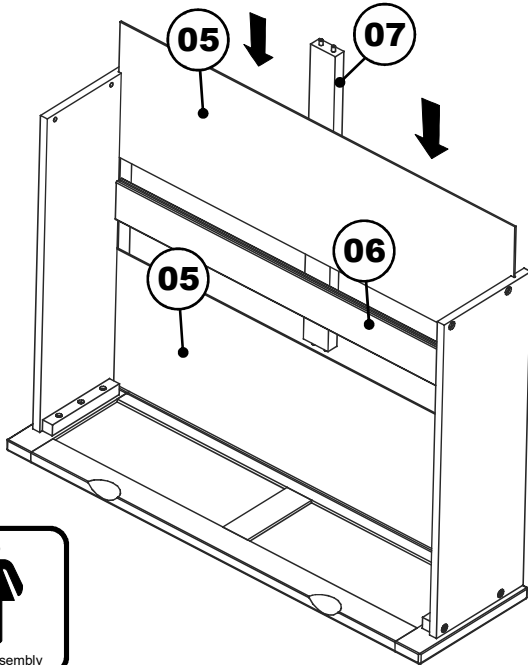

BACK VIEW

Step 3

Attach drawer back (04) to bed drawer assembly as shown. Use JCB M6 X 1" (A). Tighten with Allen wrench (C). Use wood screws 1 1/4" (B) to finish attaching drawer center support (07) to drawer back (04). Tighten with Phillips head screw driver. (customer supplied)

Step 4

Lastly, insert bed drawer to the bed as shown below.

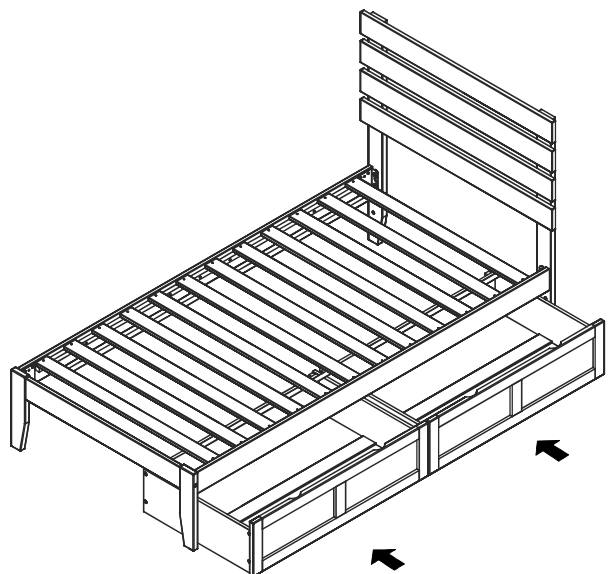
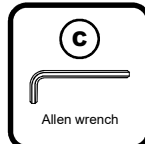
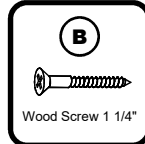
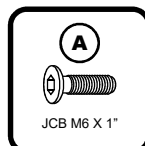
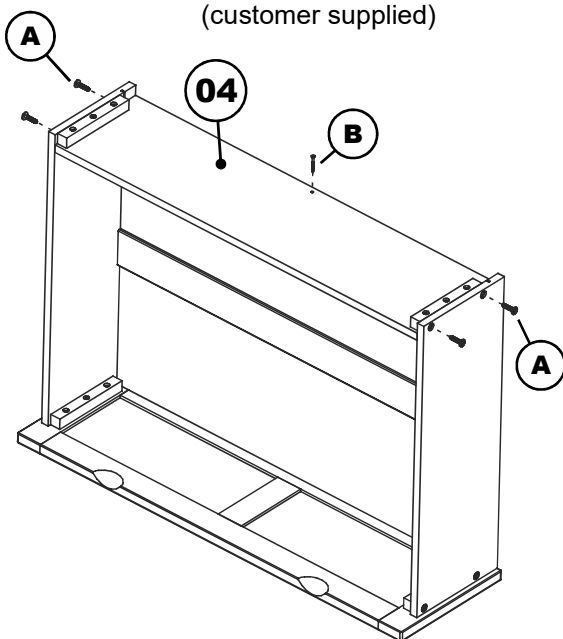

Congratulations!

Your bed drawer is now ready for use.

We recommend that you periodically recheck that all screws are tight to ensure lasting safety.