

EN_IMPORTANT, RETAIN FOR FUTURE REFERENCE: READ CAREFULLY.

USING CAM LOCK AND QUICKFIT

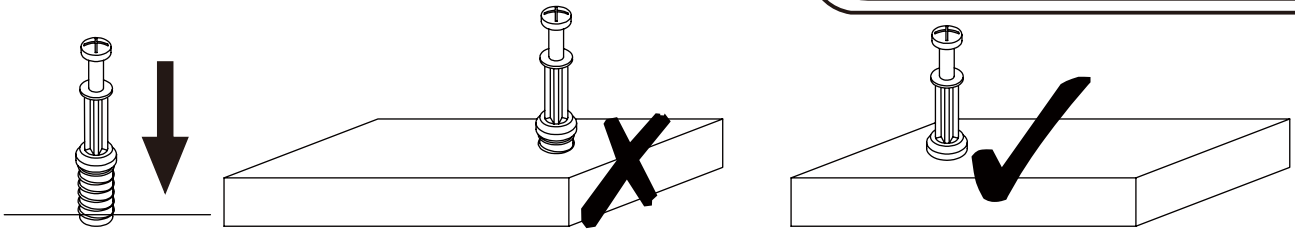

EN_QUICKFIT: Tighten quickfit until shoulder is flush with panel. Do not overtighten or undertighten.

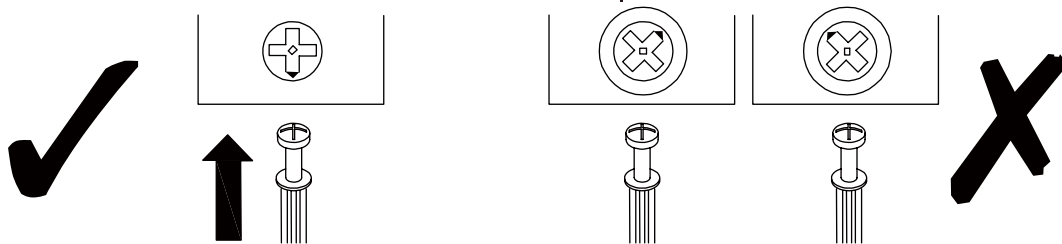

EN_CAM LOCK: When fitting cam lock, ensure starting position is correct before you insert connecting quickfit.

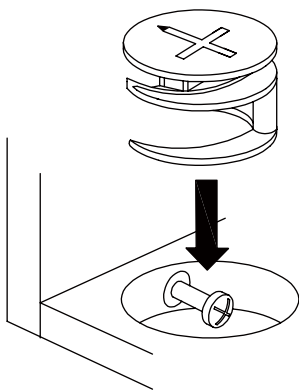

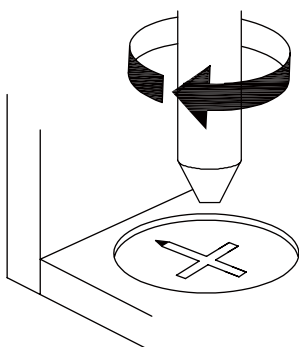

EN_Quickfit head should be in the centre of the cam lock when the two panels are joined.
Cam lock should be inserted before quickfit.



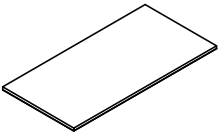
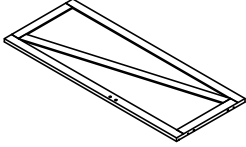
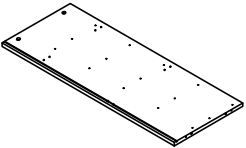
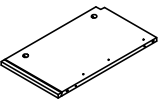
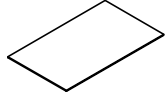
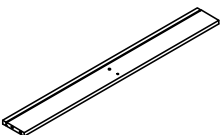
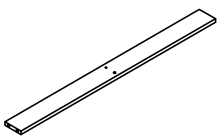
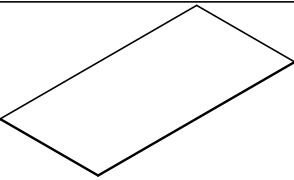
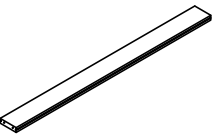
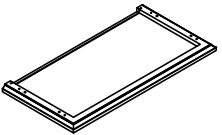

EN_Turn cam lock clockwise to tighten.

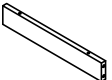

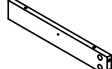
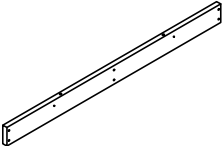
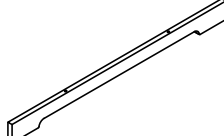
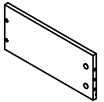
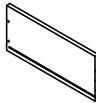
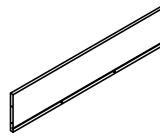
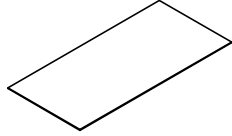
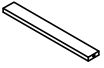

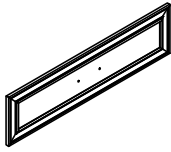
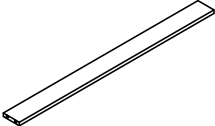
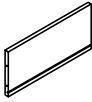
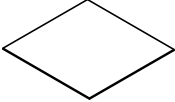
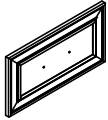
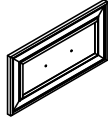



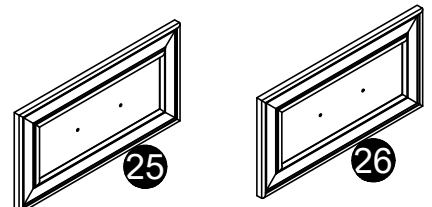
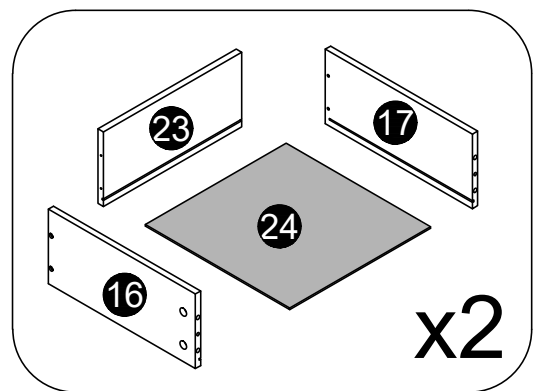
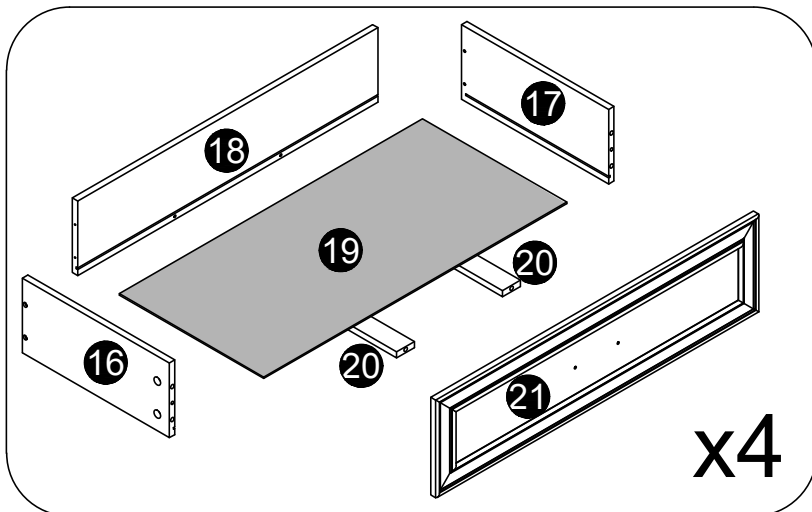
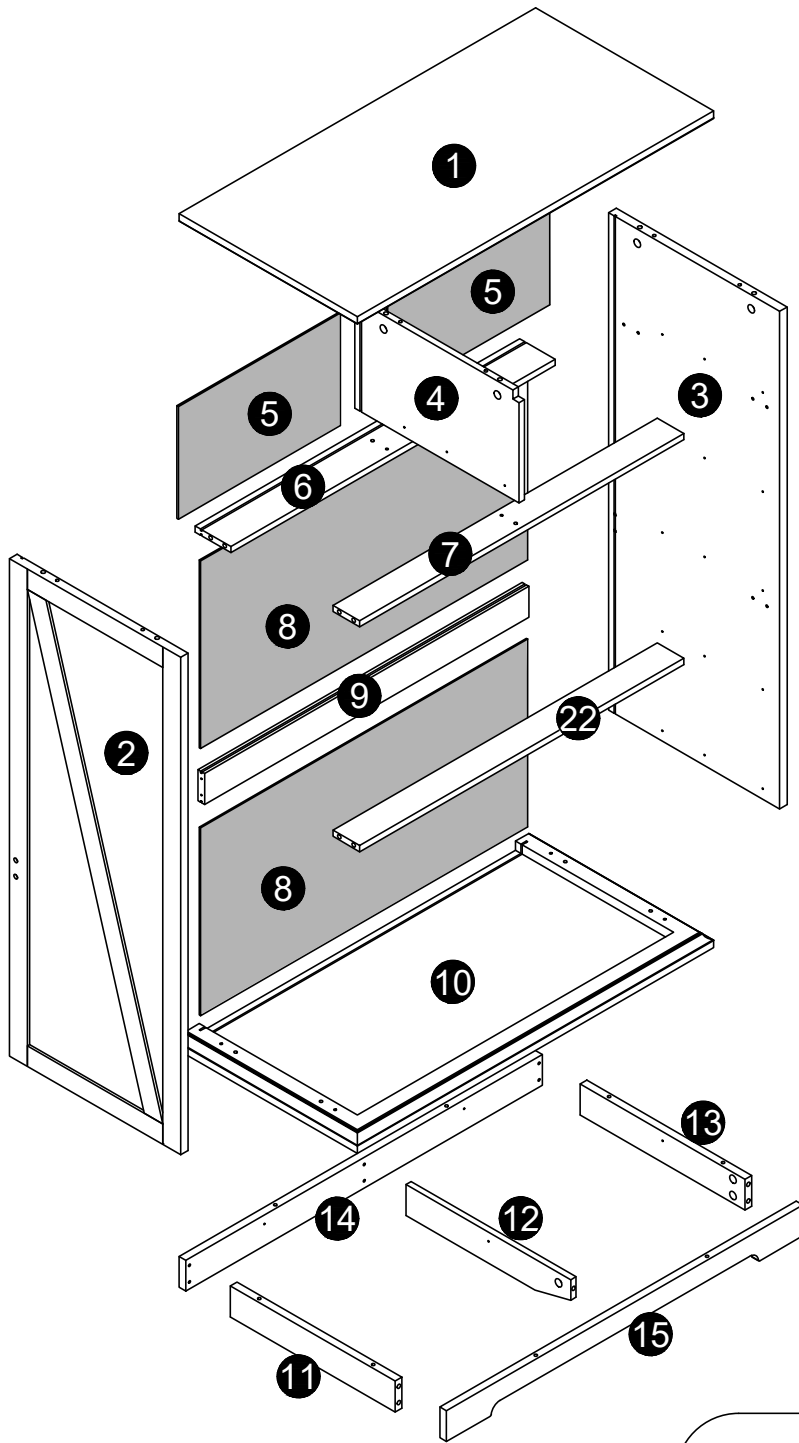

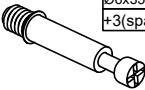
PACKING DELALS

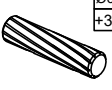
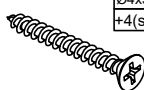

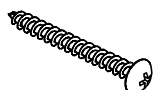
NO.	PARTS	QTY	SPARE
①		x1	
②		x1	
③		x1	
④		x1	
⑤		x2	
⑥		x1	
⑦		x1	
⑧		x2	
⑨		x1	
⑩		x1	

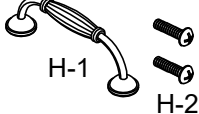
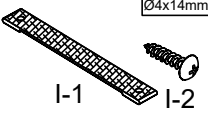
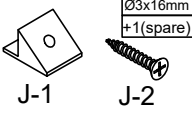
NO.	PARTS	QTY	SPARE
⑪		x1	
⑫		x1	
⑬		x1	
⑭		x1	
⑮		x1	
⑯		x6	
⑰		x6	
⑱		x4	
⑲		x4	
⑳		x8	

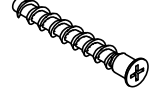
NO.	PARTS	QTY	SPARE
②1		x4	
②2		x1	
②3		x2	
②4		x2	
②5		x1	
②6		x1	
	 Hardware Kit	x1	

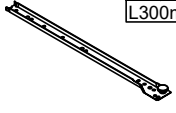
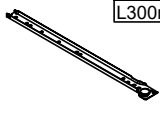
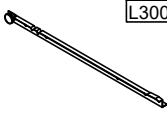
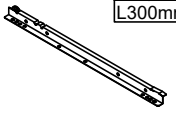

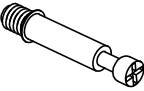
 A x55 Ø6x35mm +3(spare)	 B x55 Ø15x10mm +3(spare)	 C x32 Ø6x30mm +3(spare)	 D x42 Ø4x35mm +4(spare)	 E x86 +8(spare)	 F x4
 G x7	 H x6 H-1 H-2	 I x2 Ø4x14mm I-1 I-2	 J x16 Ø3x16mm +1(spare) J-1 J-2	 K x2 Ø6x30mm	 L x4
 M x4 Ø15mm +1(spare)	 N x12	 CL x6 L300mm	 CR x6 L300mm	 DL x6 L300mm	 DR x6 L300mm

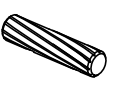
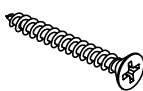
 A x8	 B x8	 C x4	 D x8
--	--	--	--

01

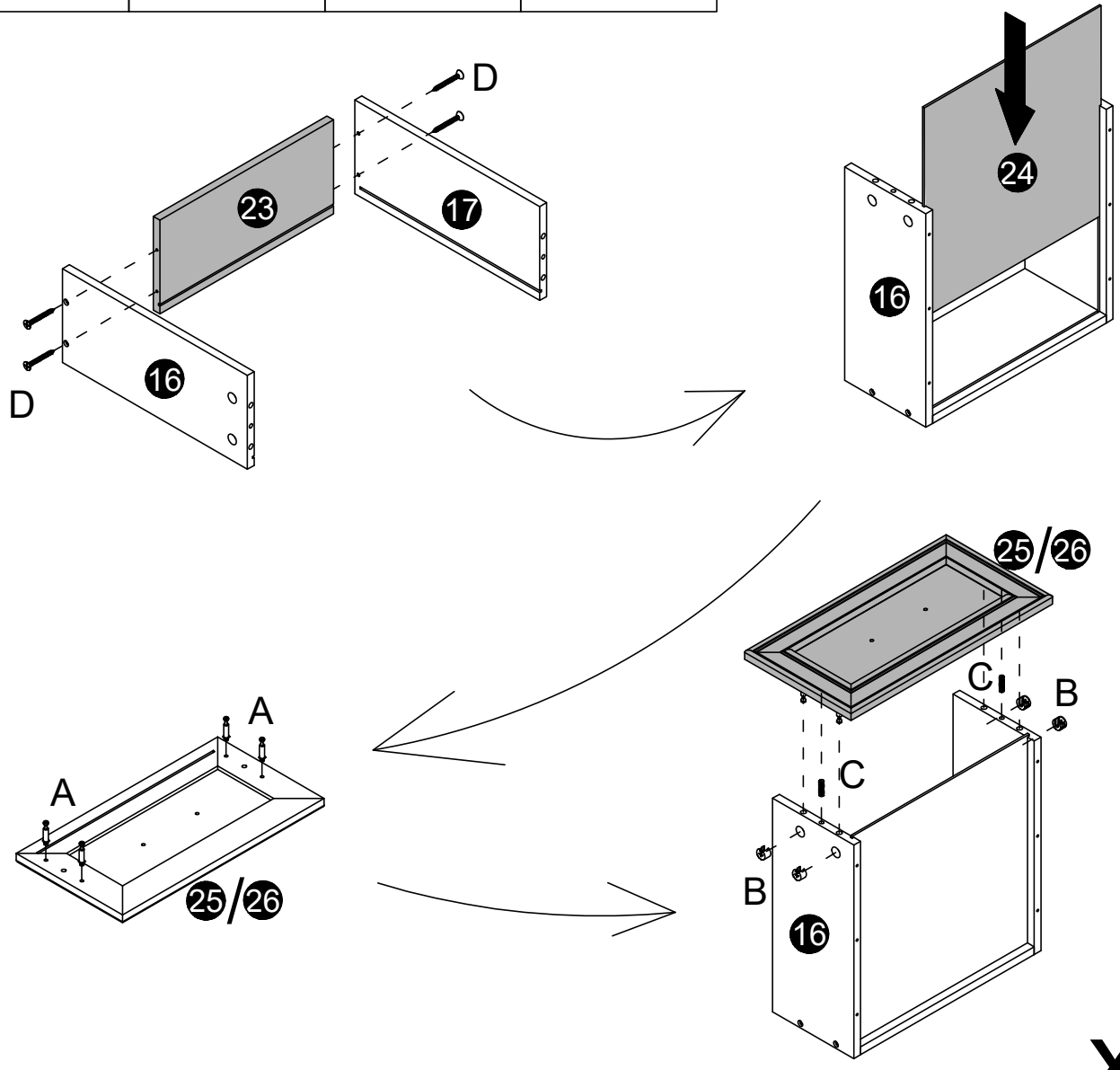

x2

A x24

B x24

C x8

D x24

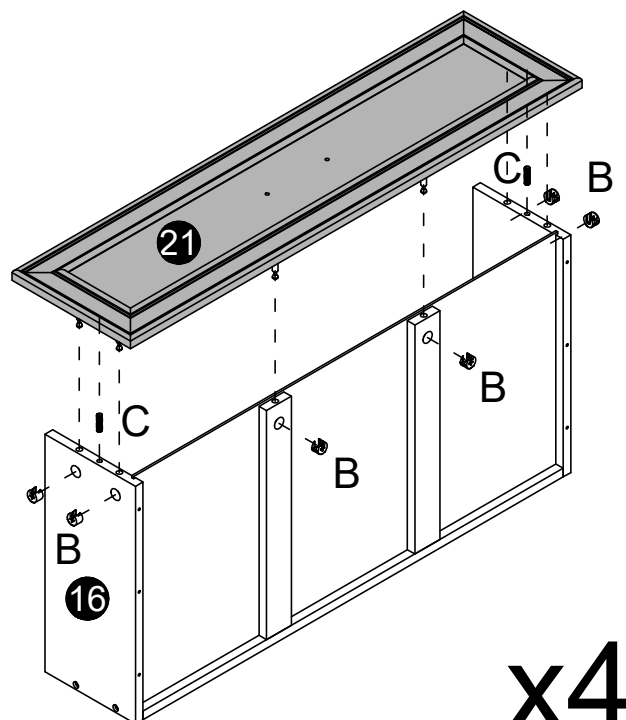
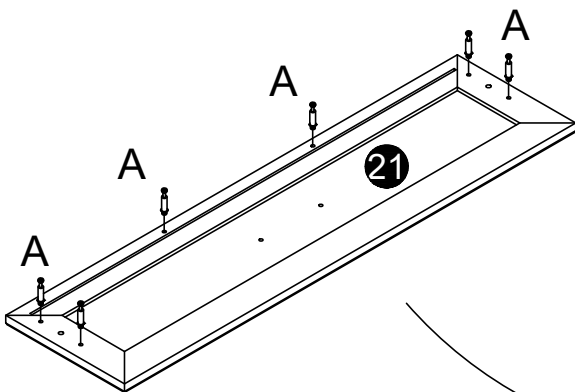
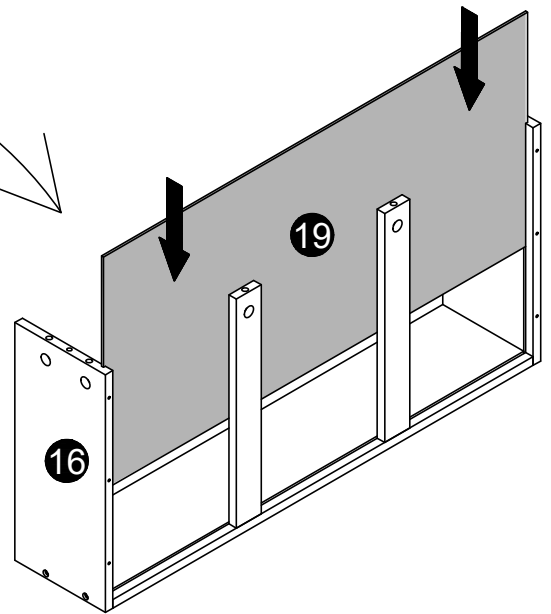
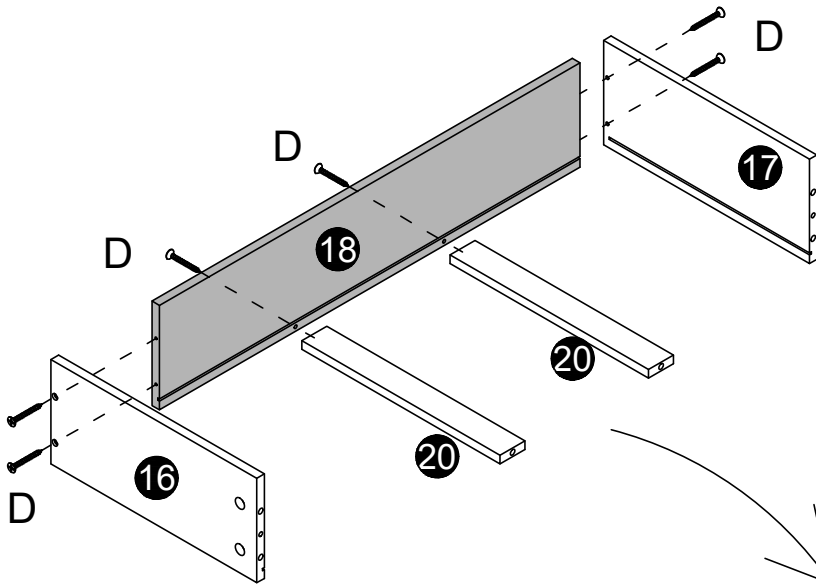
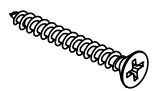
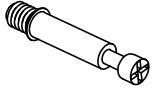

x4

E x24

DL x4

DR x4

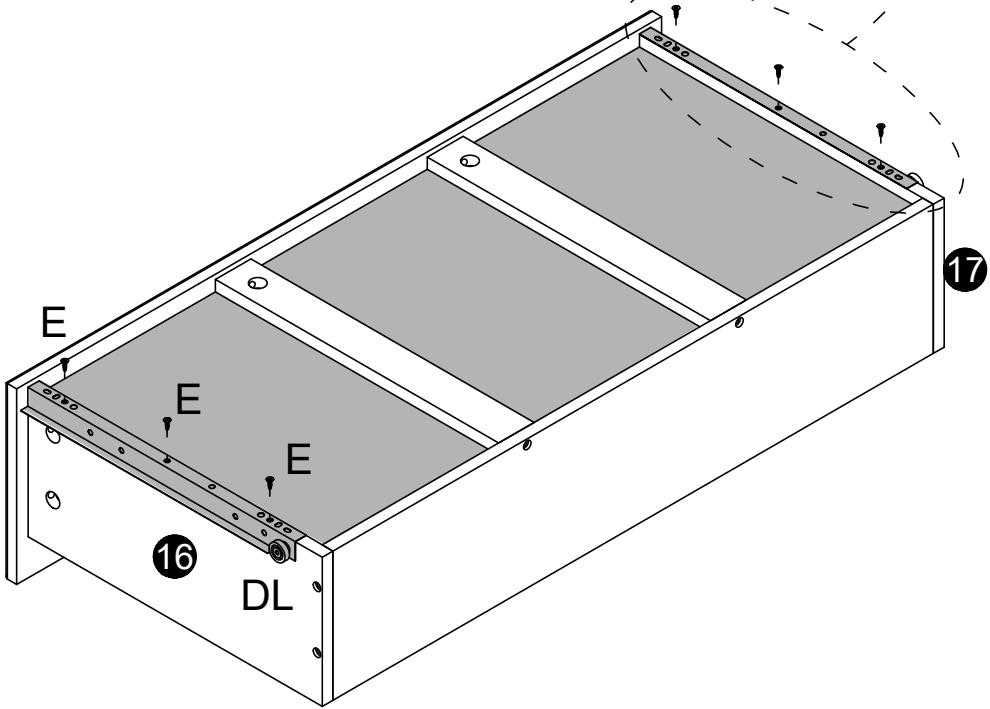
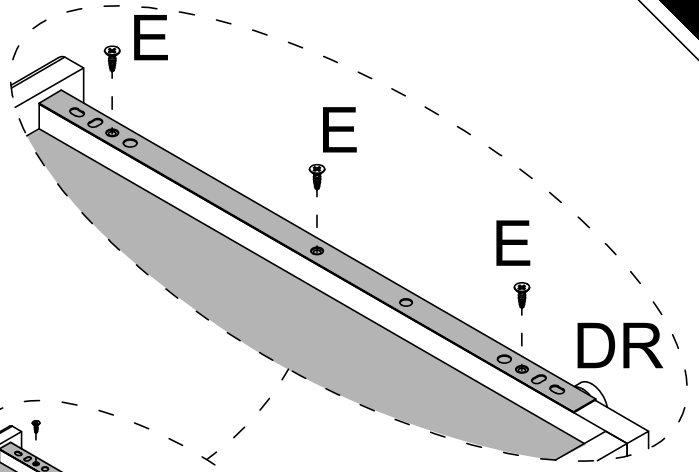
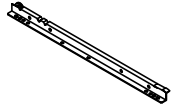
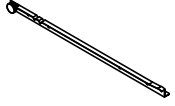

x4

H x4

N x8

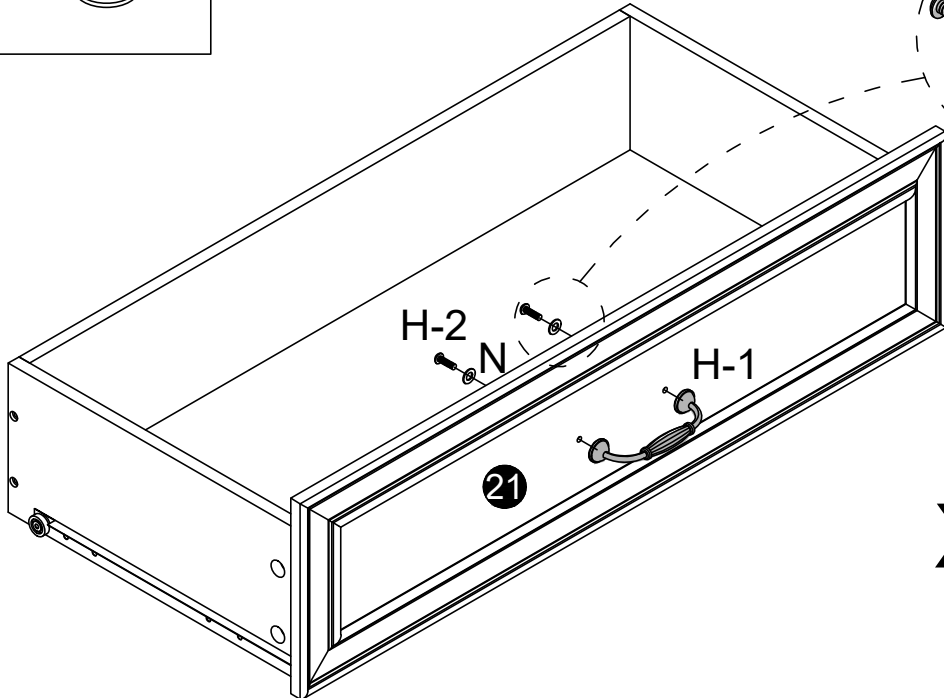
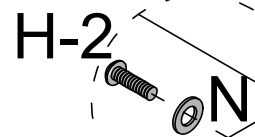
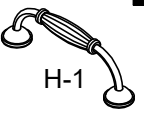

x4

A x12

E x30

CL x5

CR x5

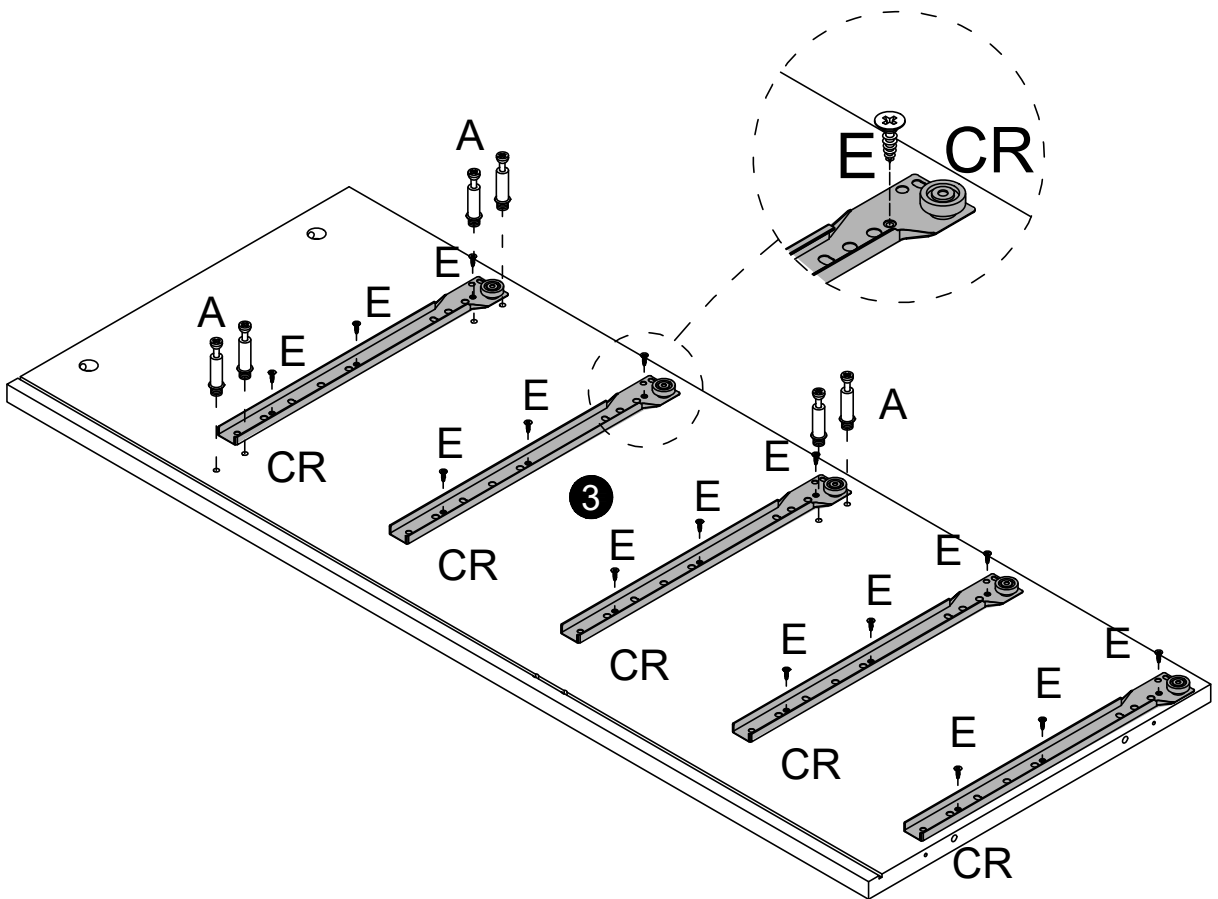
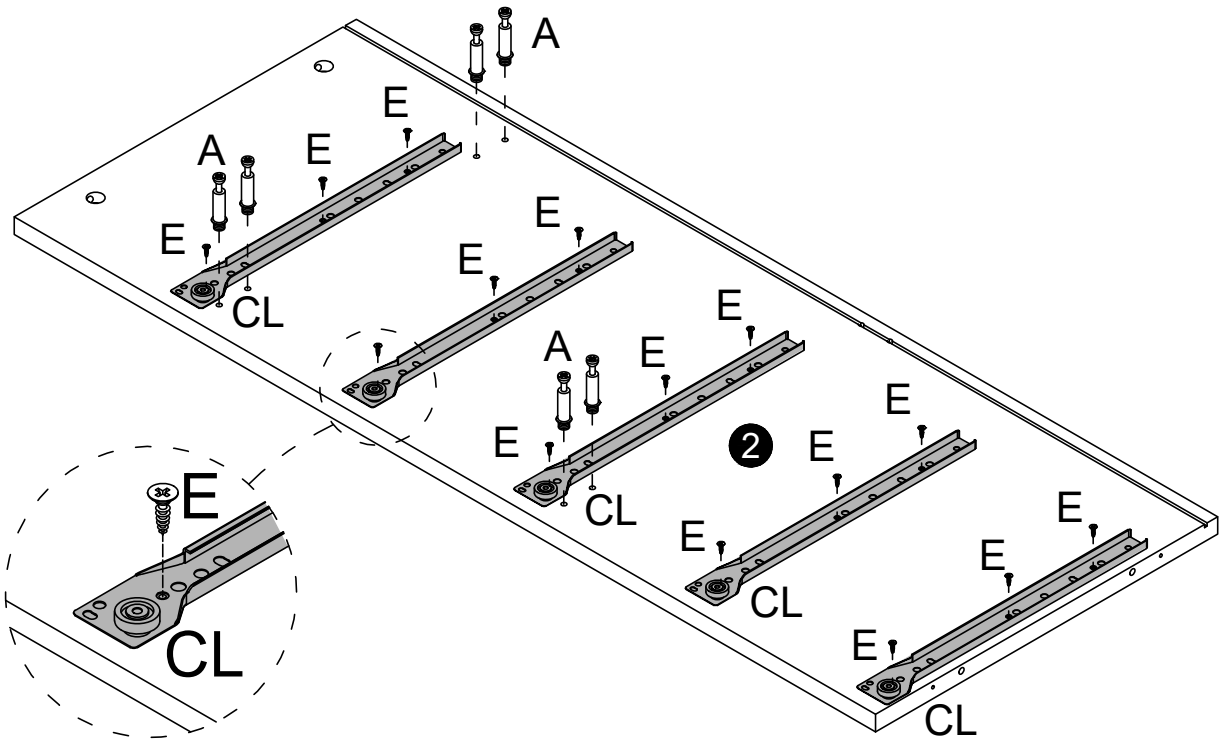
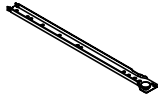
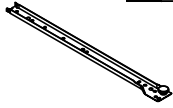
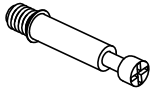

E x6

CL x1

CR x1

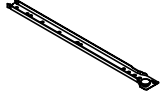
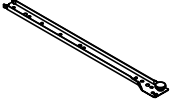

! Second hole

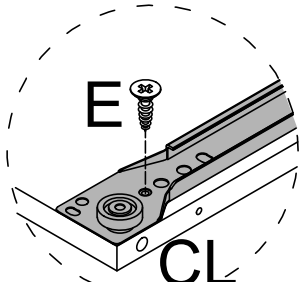
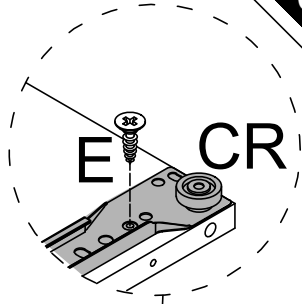

180°

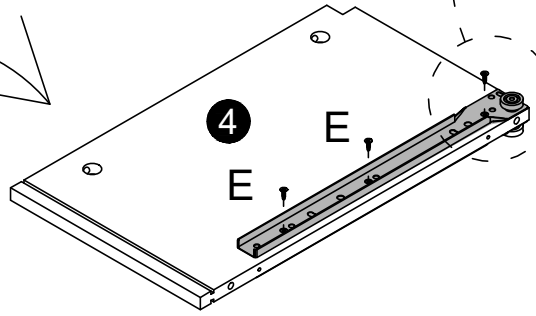
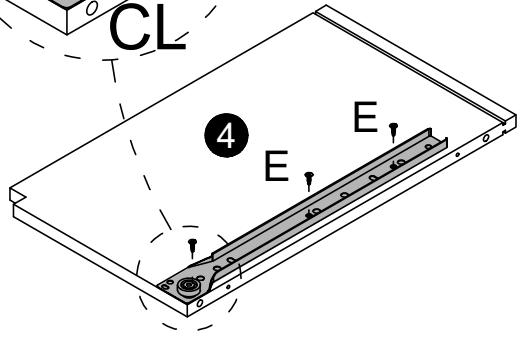

B x6

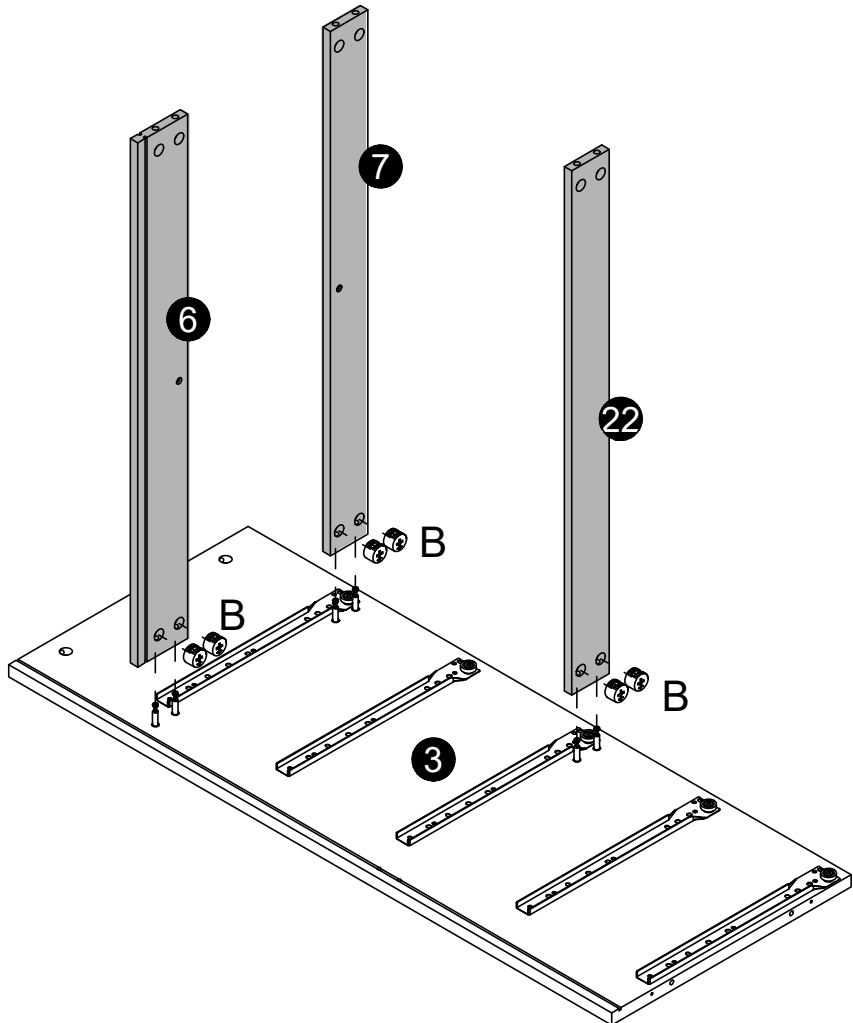

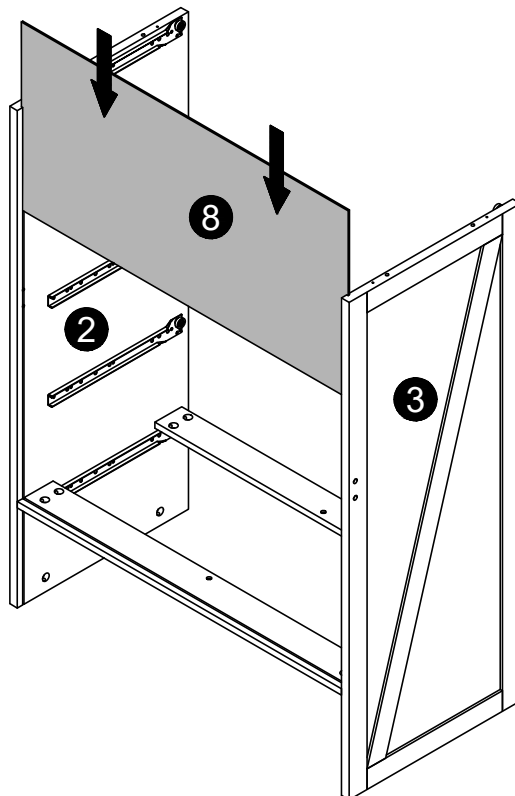
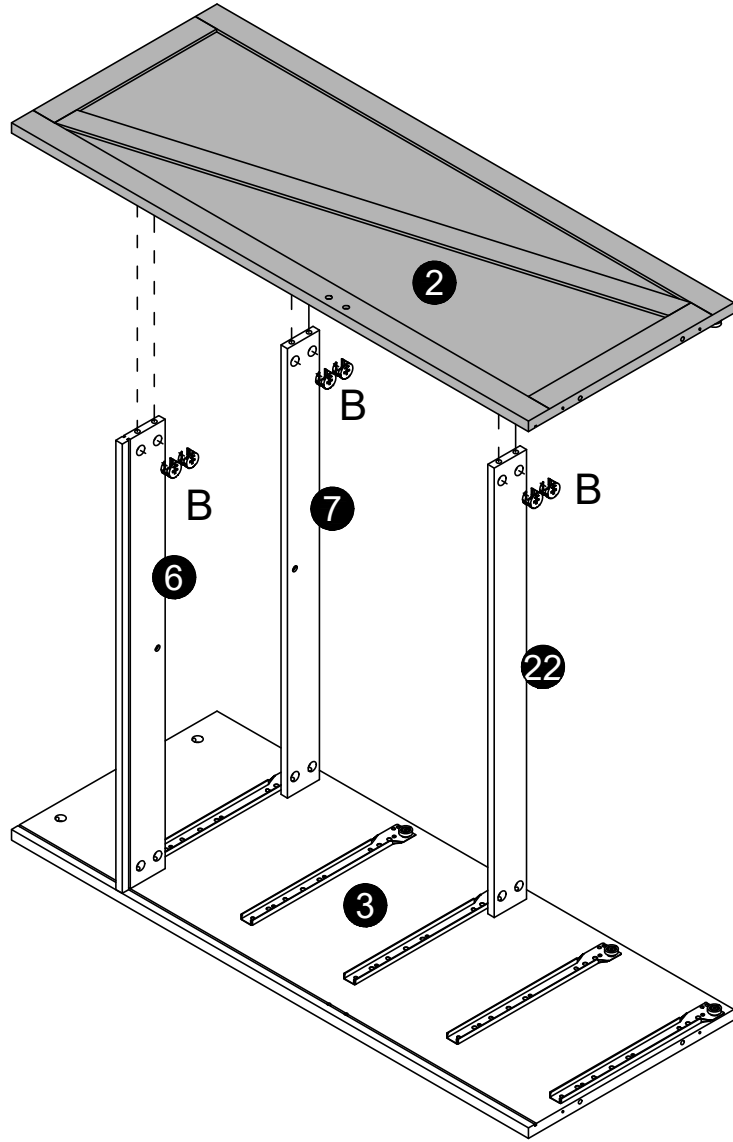

L x4

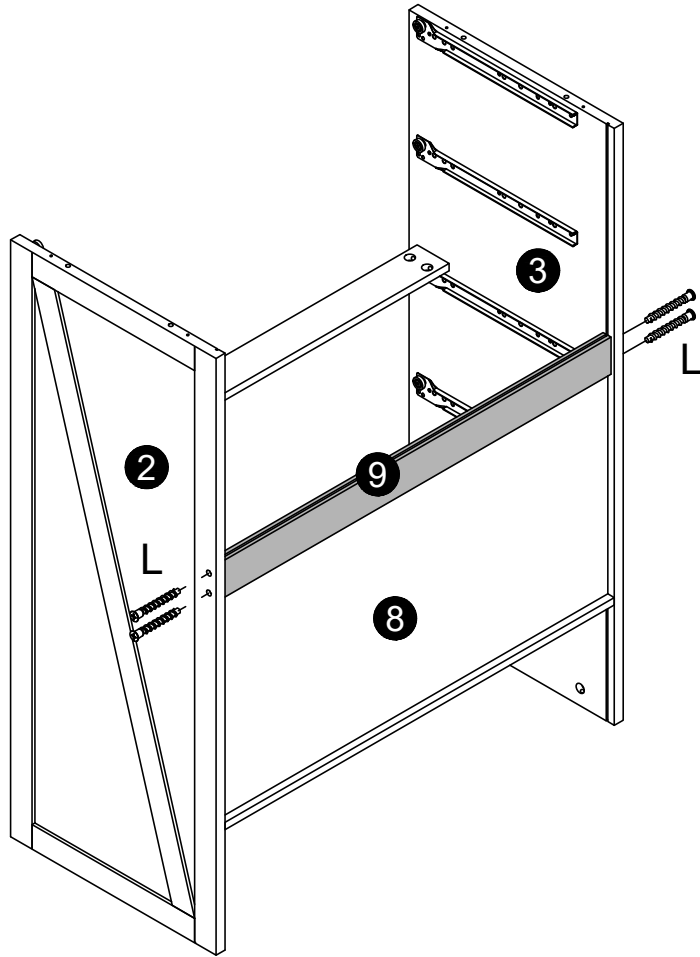
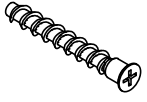

C x4

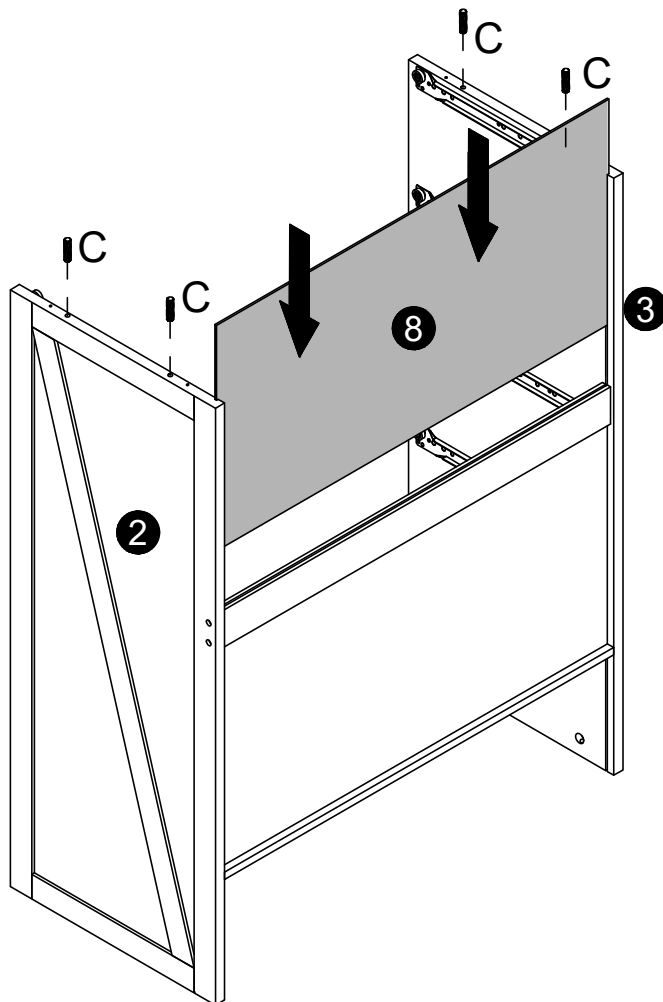

F x4

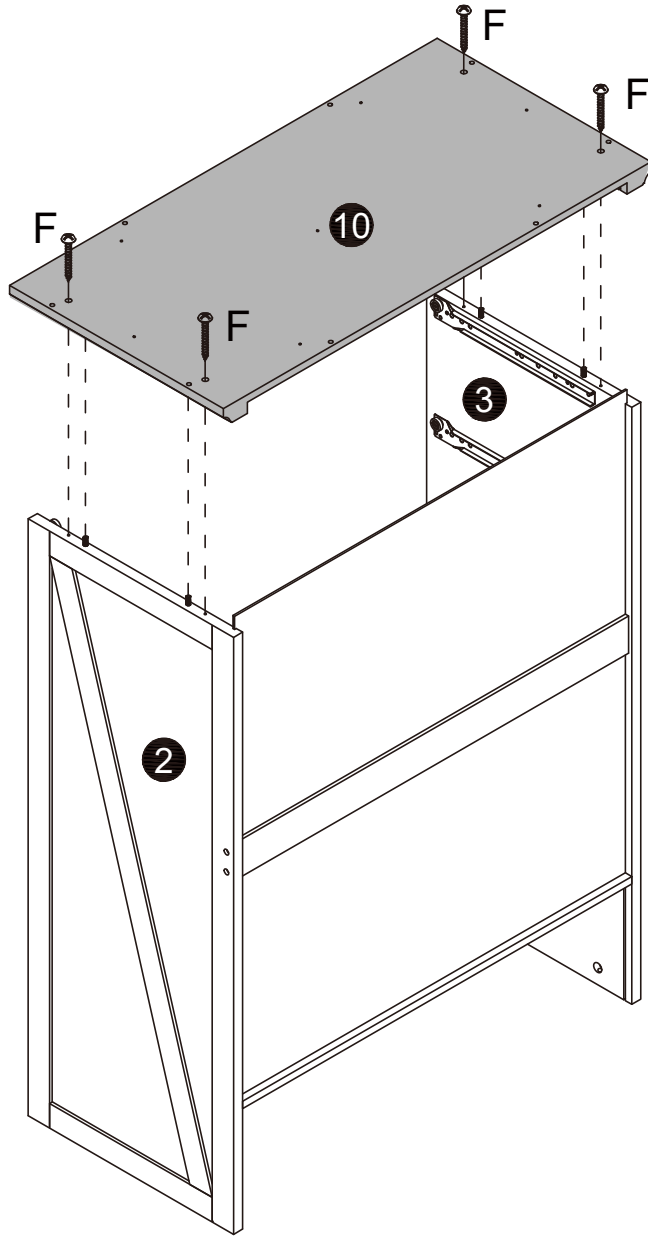
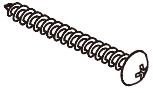

A x5

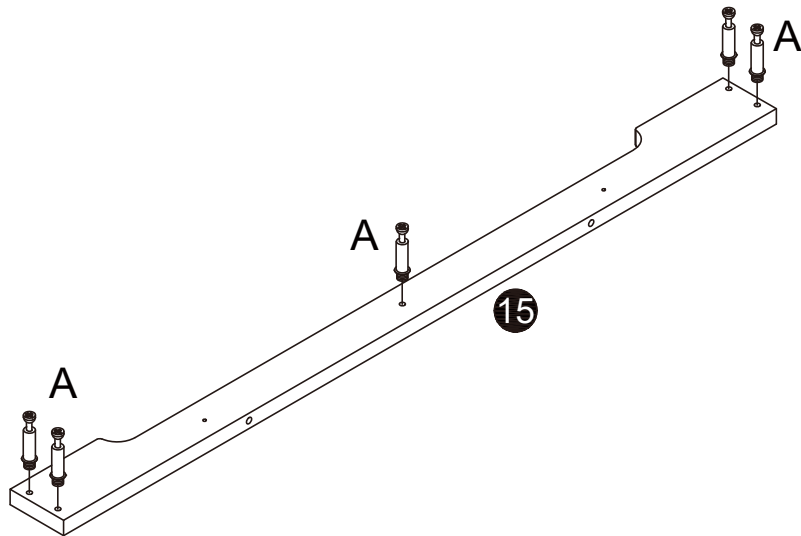
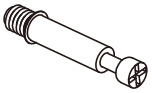

B x5

D x6

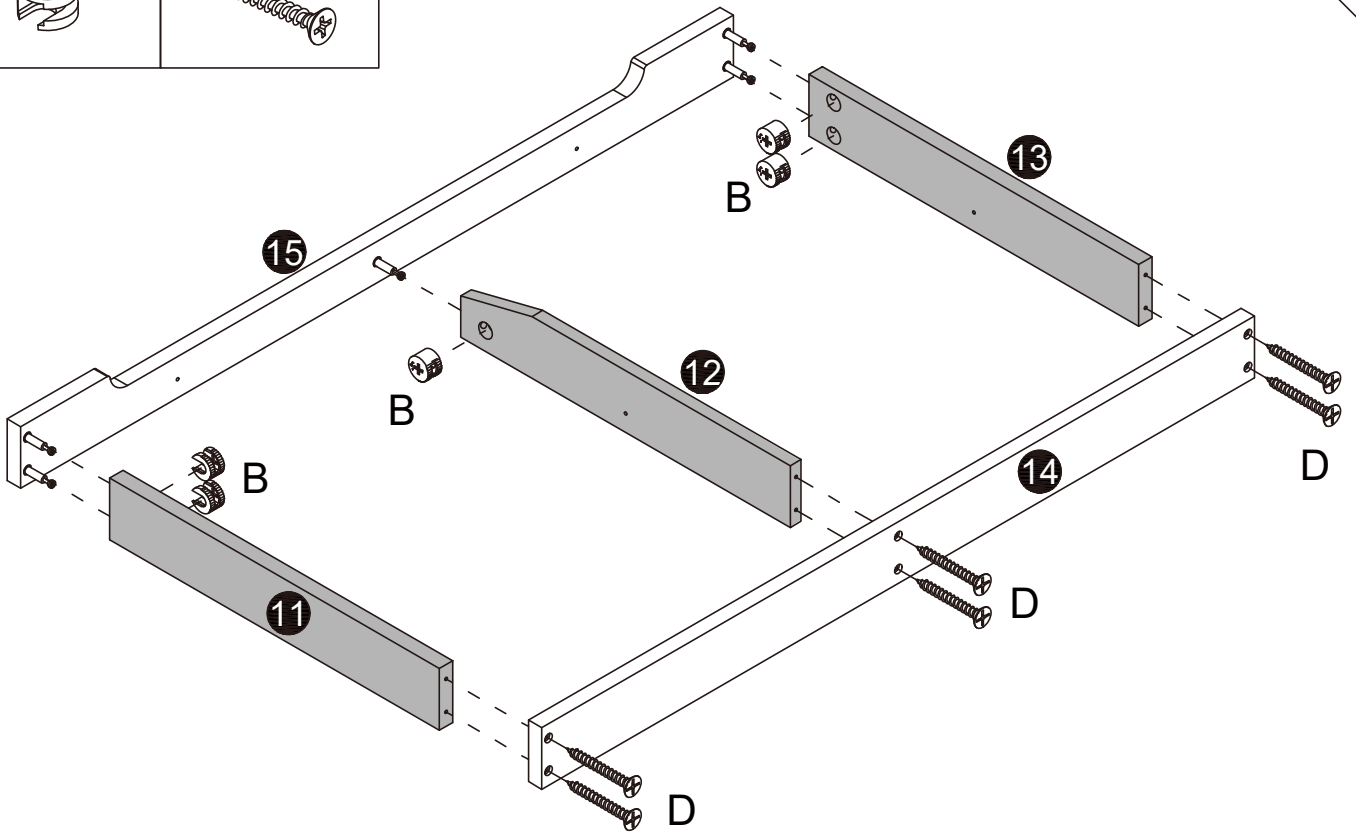
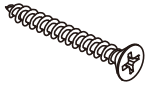

E x7

G x7

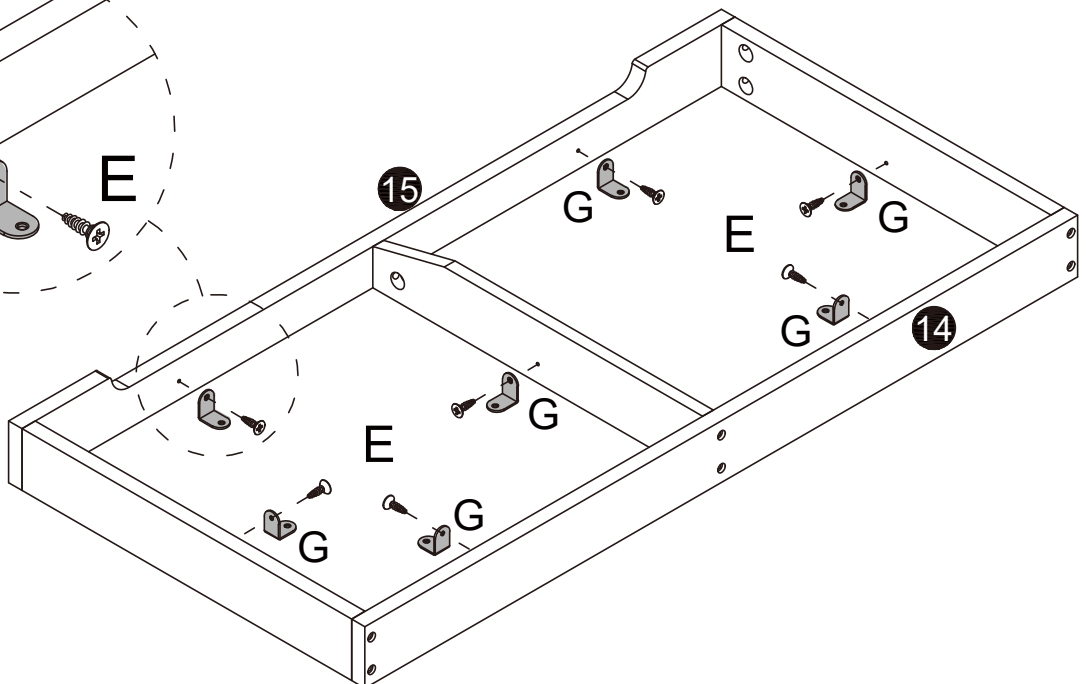
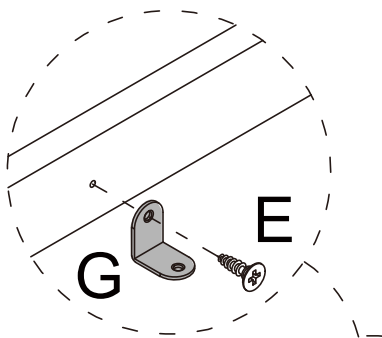

C x8

E x7

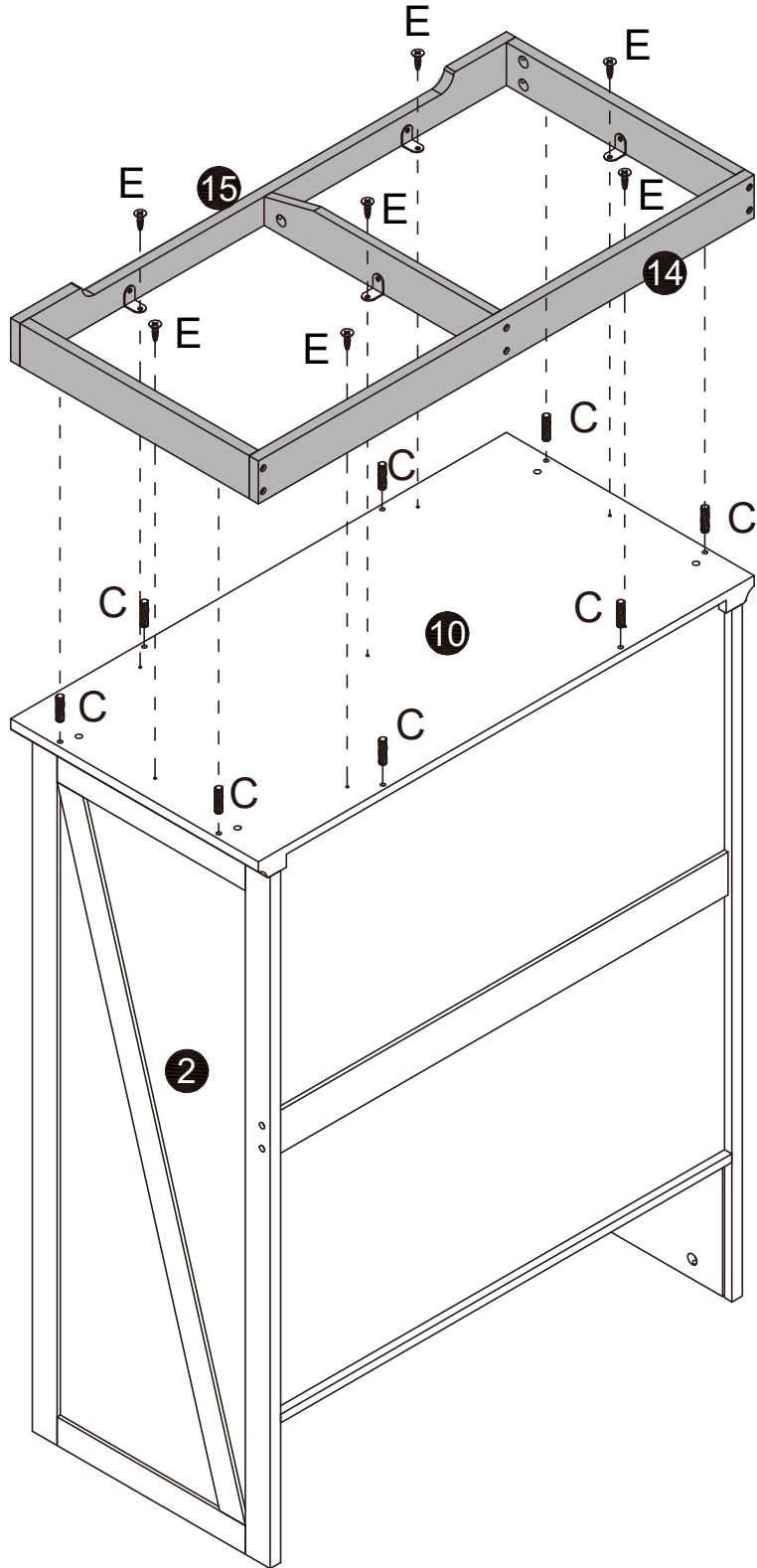

C x2

D x2

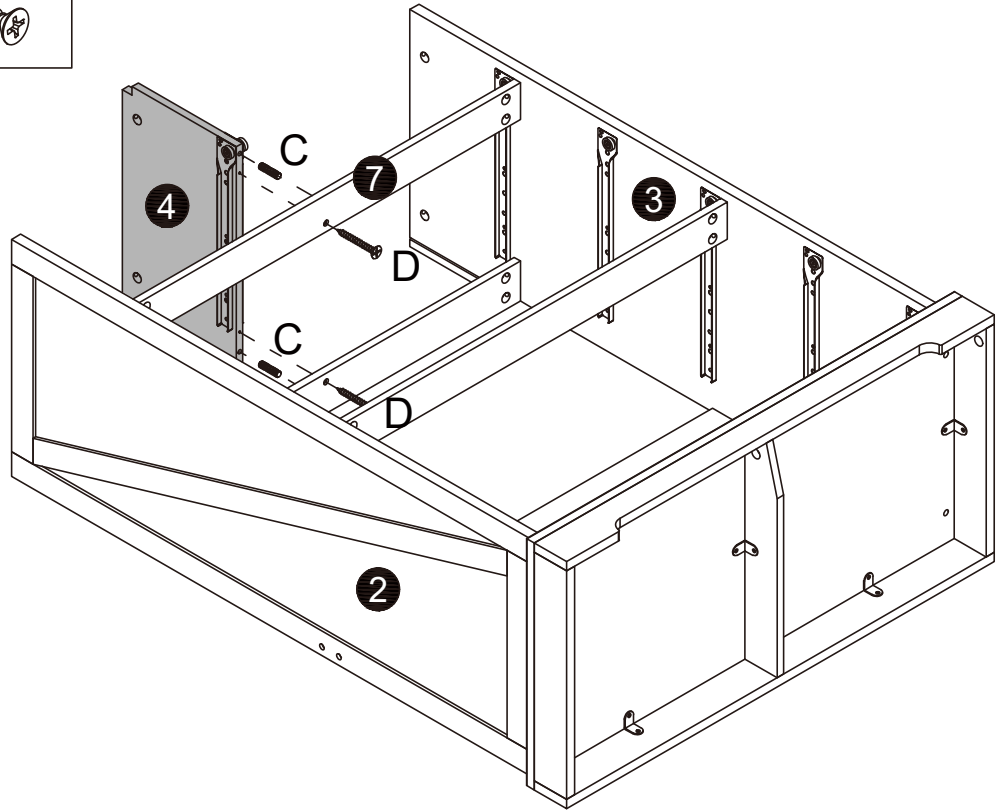
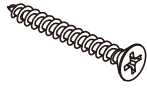

C x6

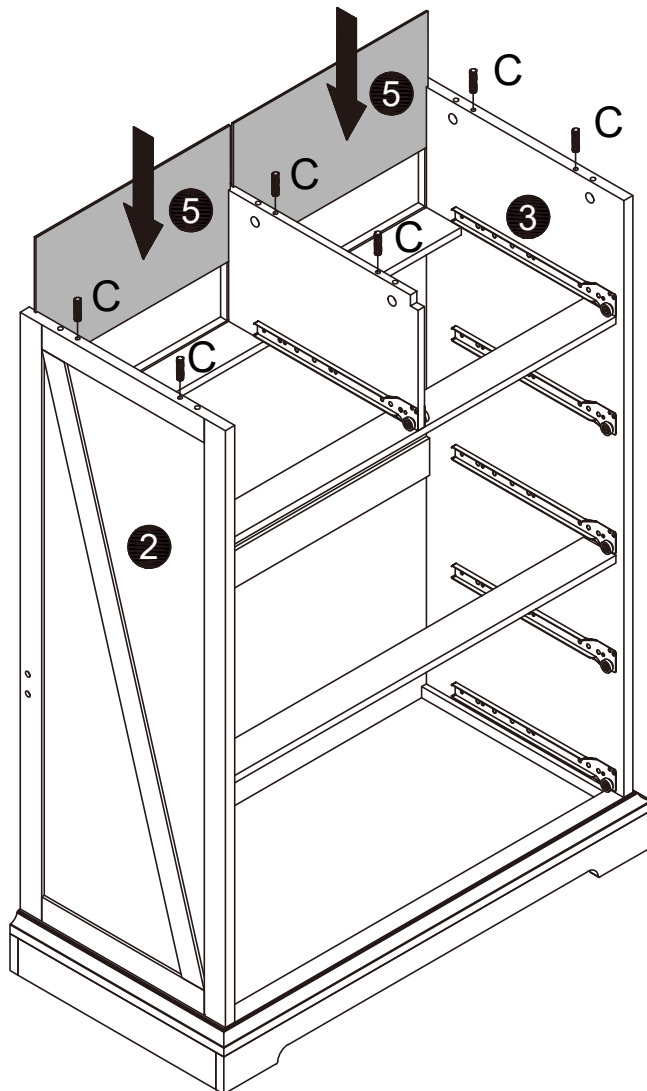
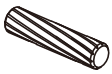

A x6

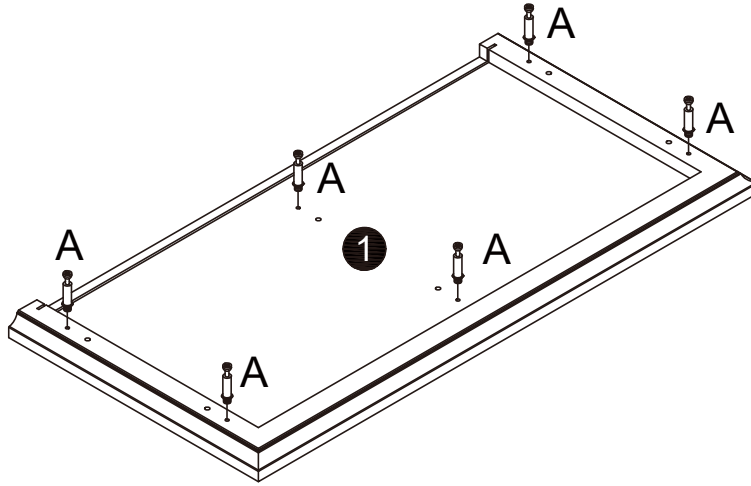
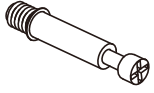

B x6

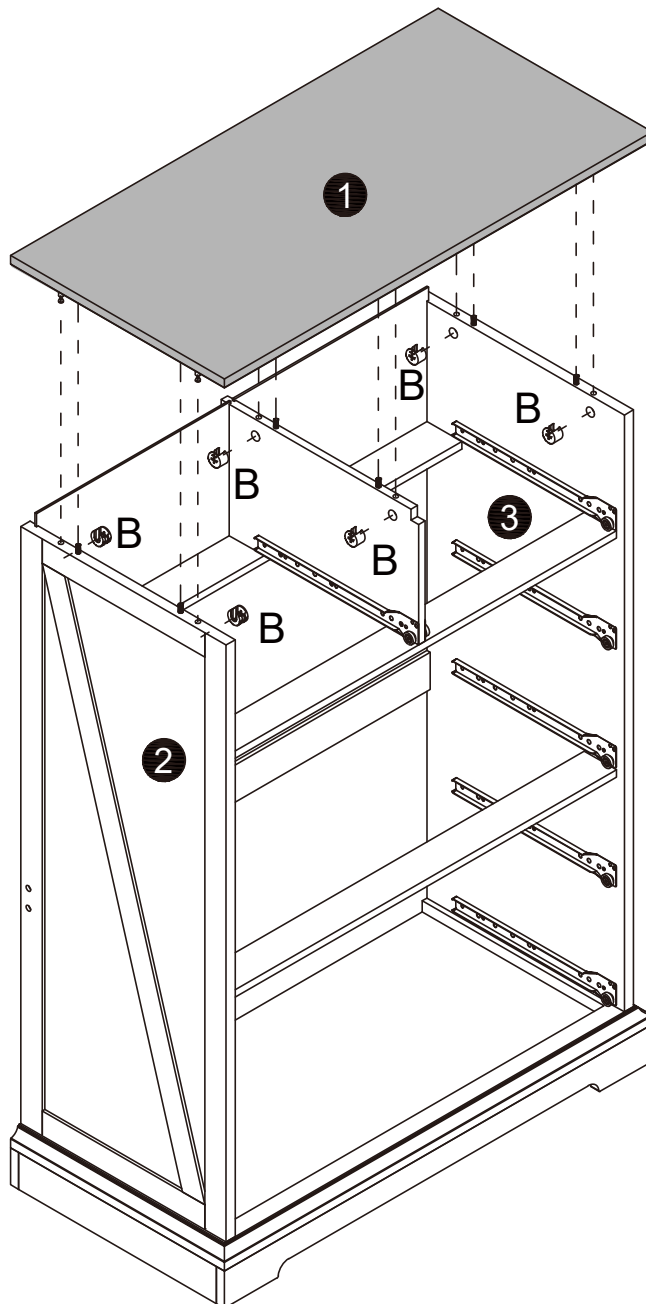

J x16



J-1



J-2

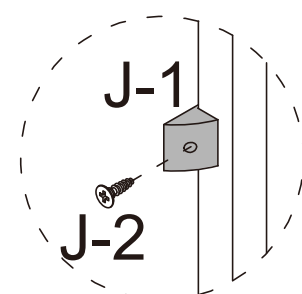
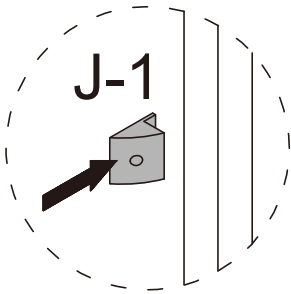
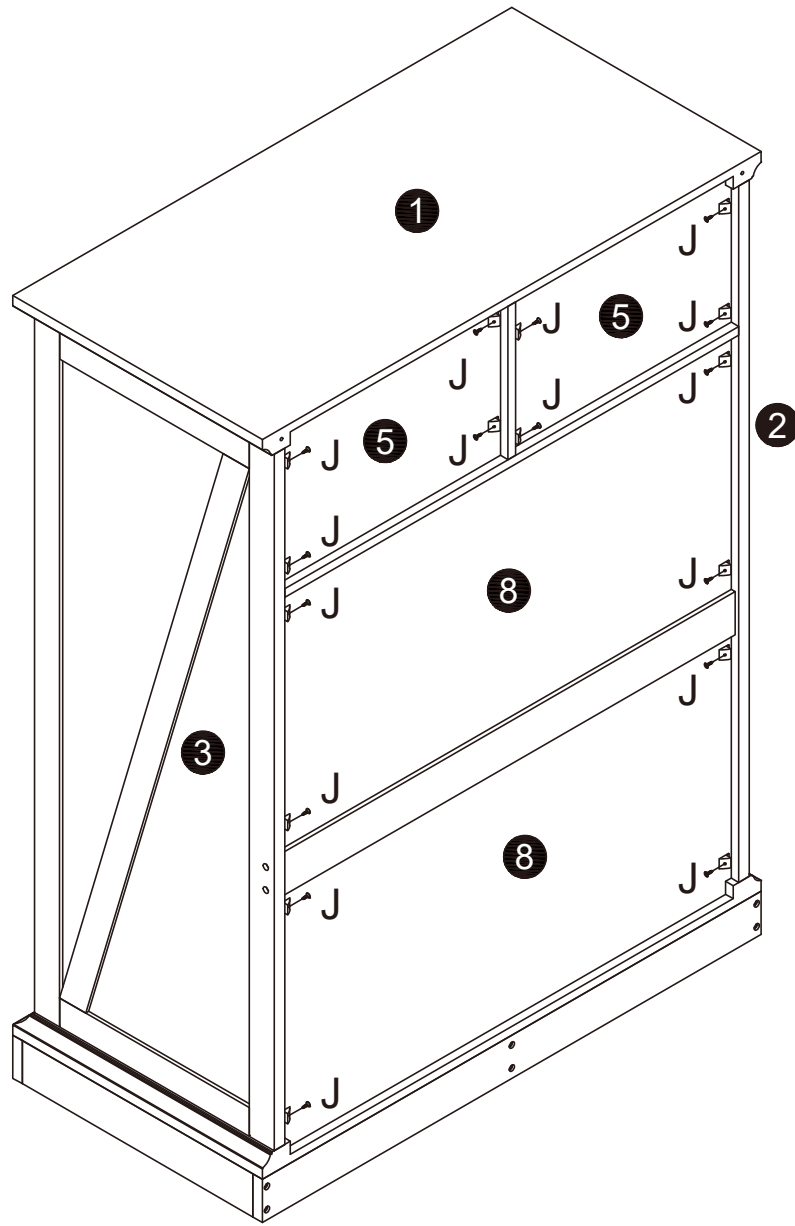

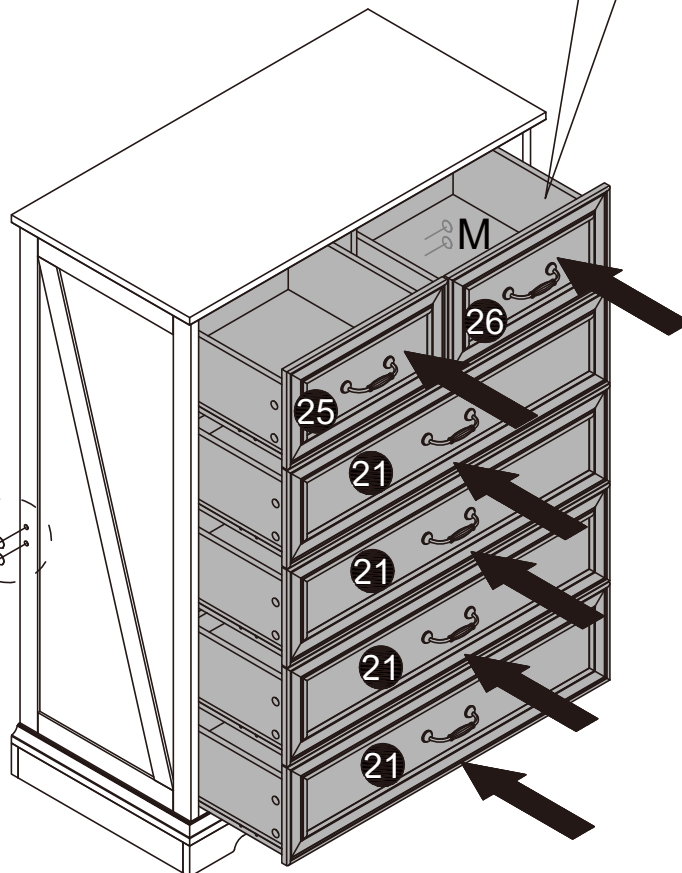
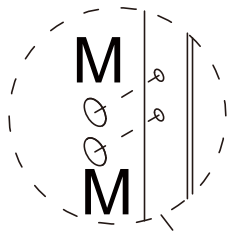
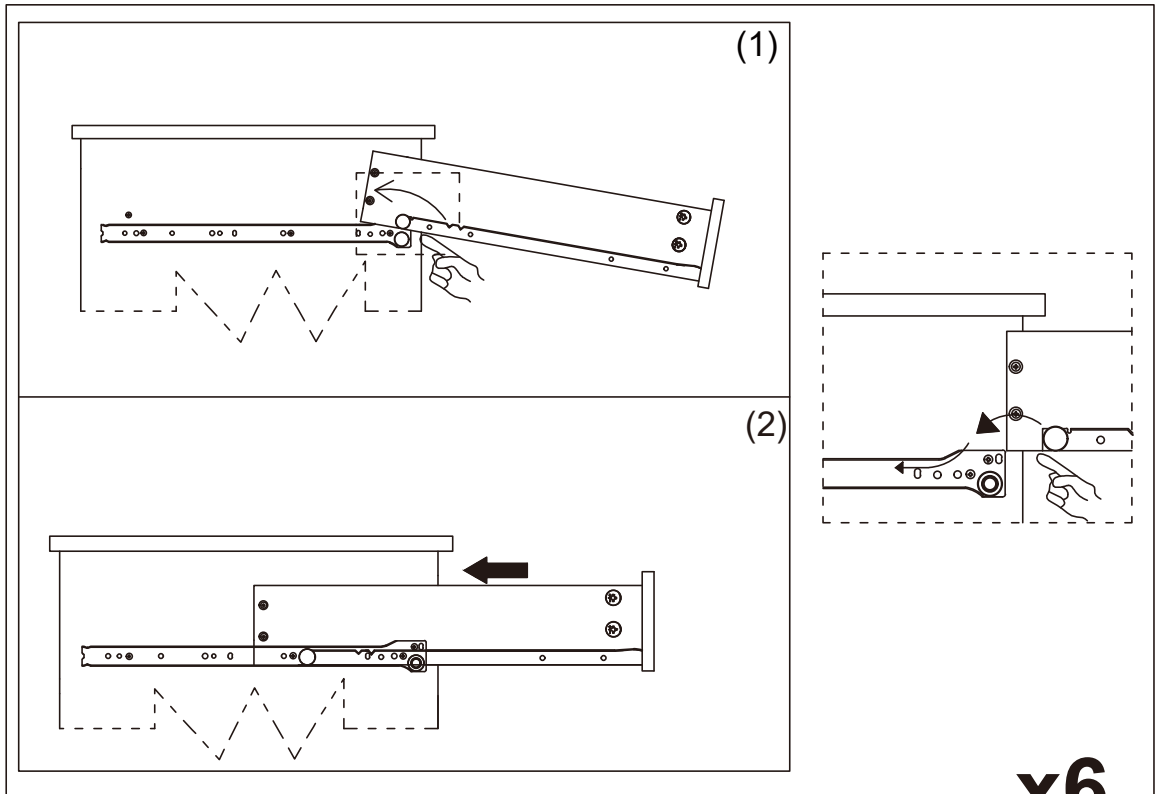

D x2

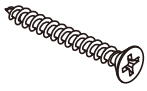

I x2

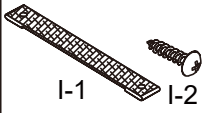

K x2

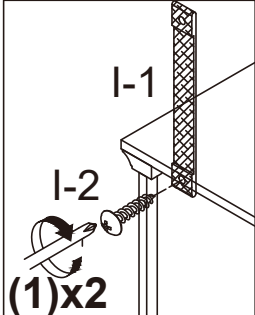
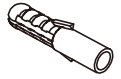

First fix the anti-rewind screw in the reserved hole of the product.

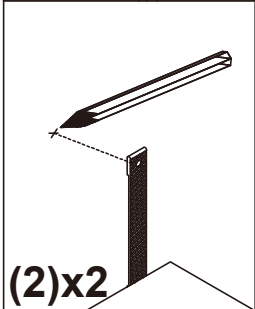

then, use a ruler to measure the approximate height of the product on the wall, and then mark it with a pen.

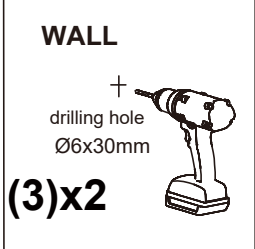

Then use a tape drill to make holes in the wall that are suitable for the product screws.

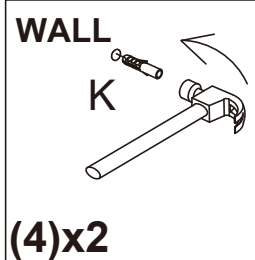

Then, put the expansion bolt into the hole

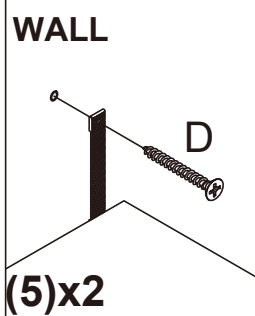

Finally, pass the matching screws through the "anti-rewind" and tighten them to fix them on the wall.

WALL

