

INSTALLATION INSTRUCTIONS

*The vessel and faucet set is not included

DIMENSIONS

Unit:inch

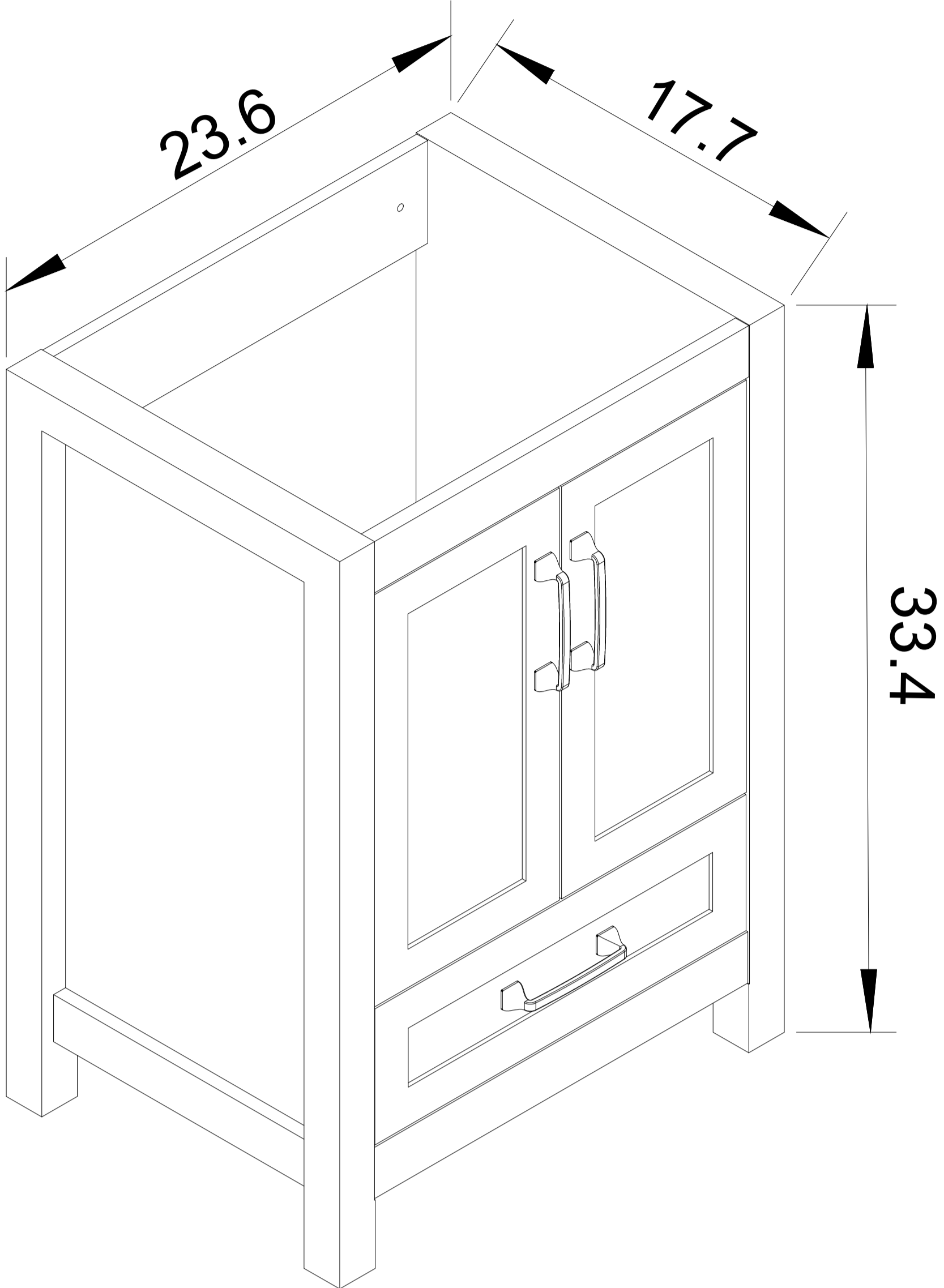

ASSEMBLY DIAGRAM

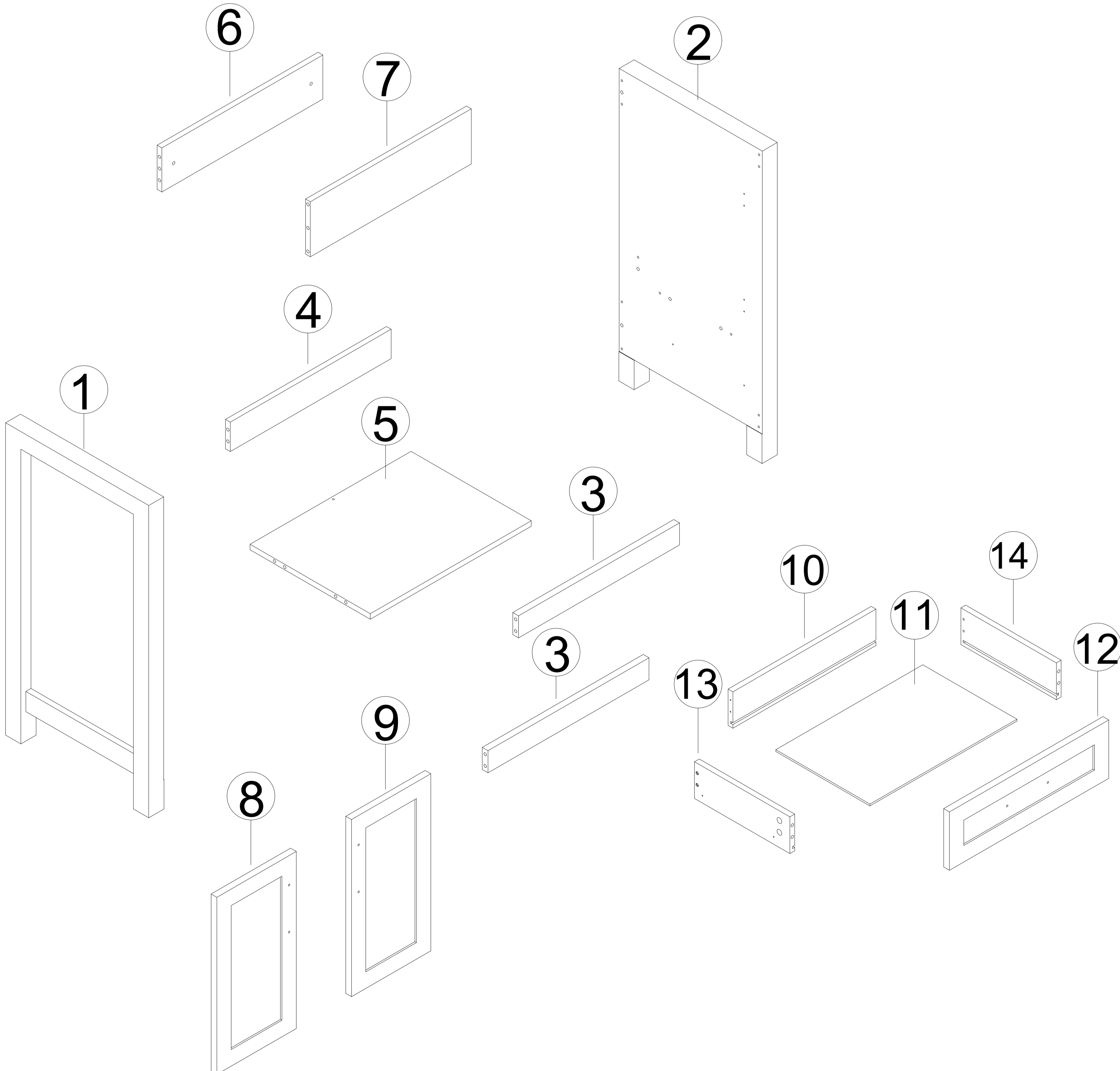

PARTS LIST

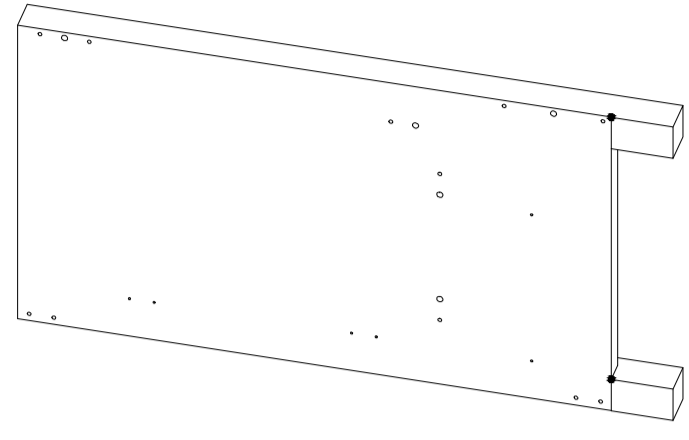
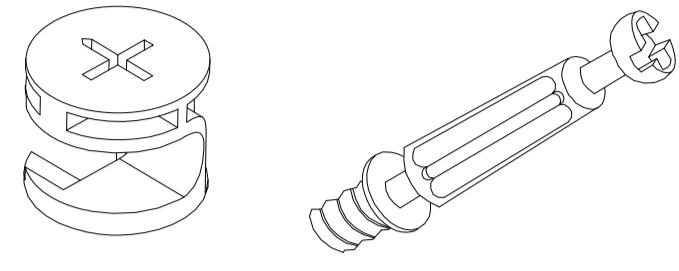
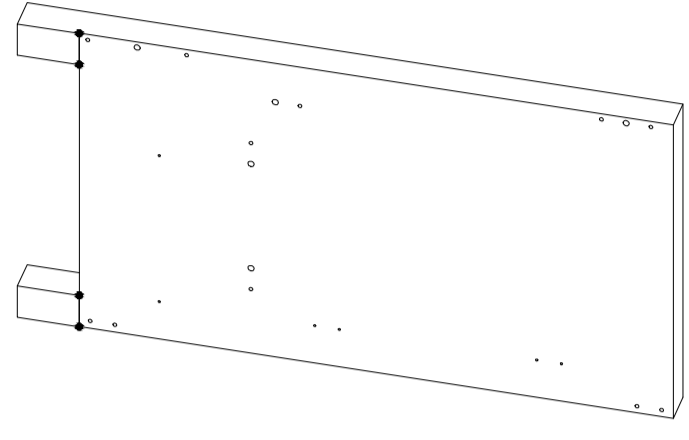
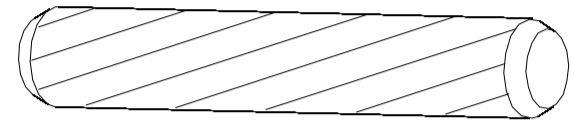
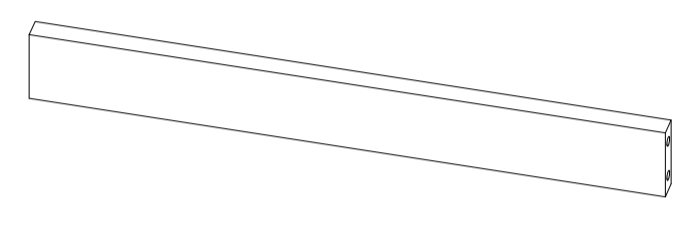
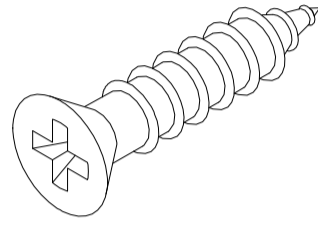
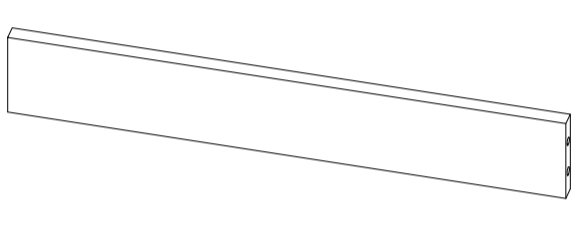
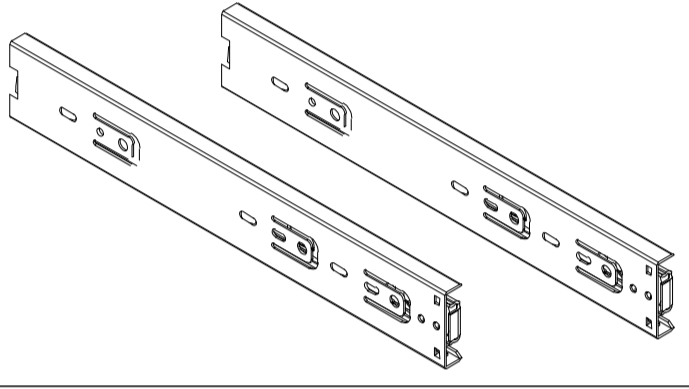
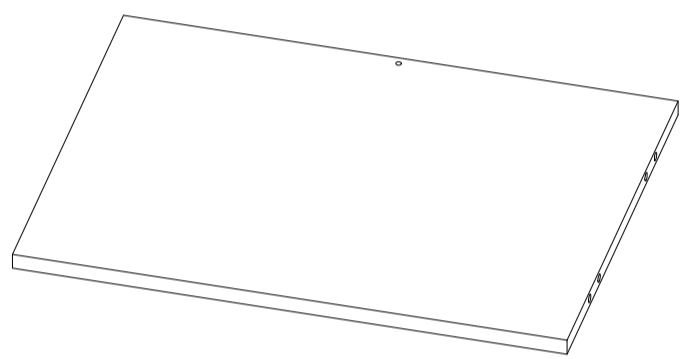
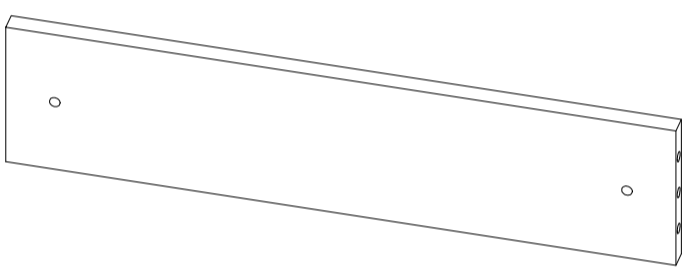
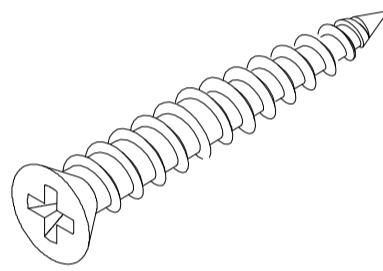
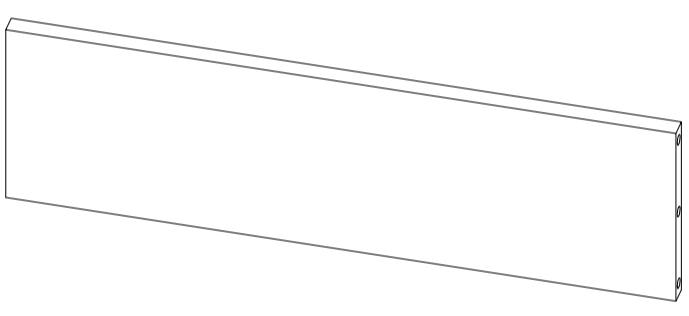
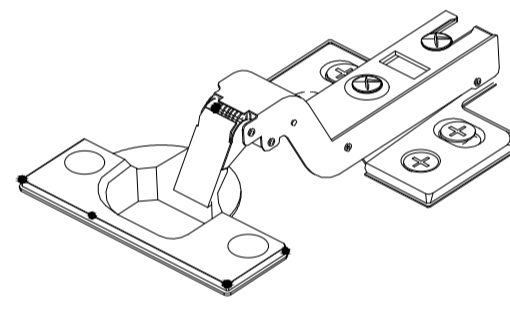
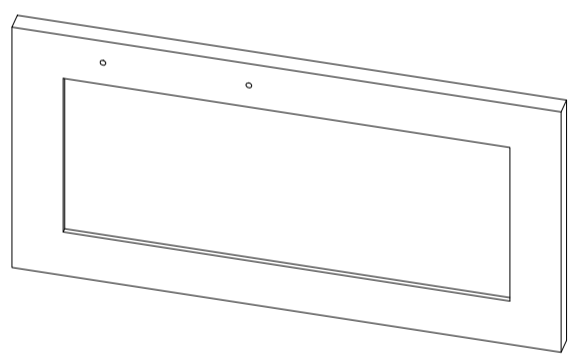
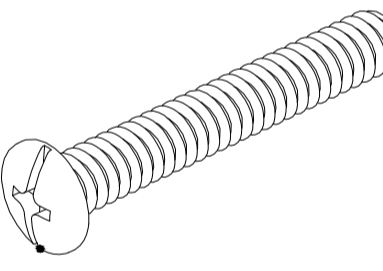
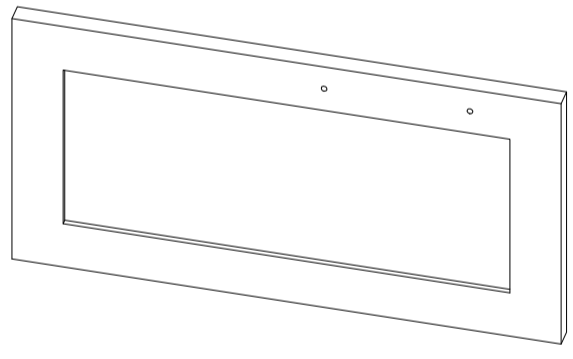
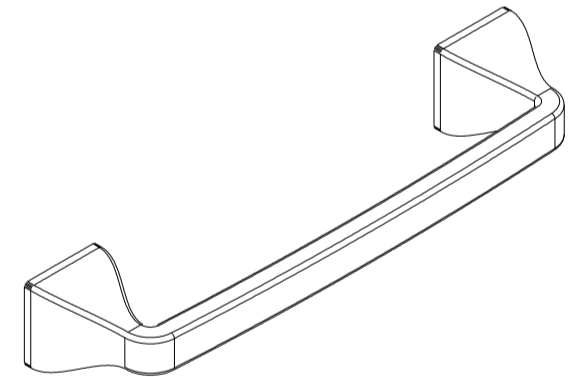
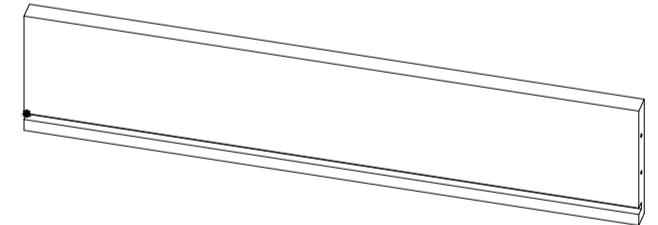
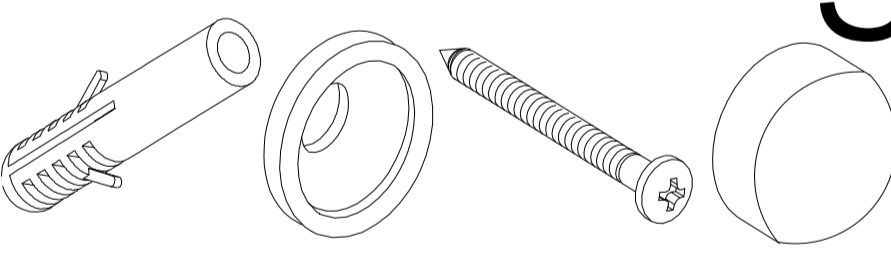
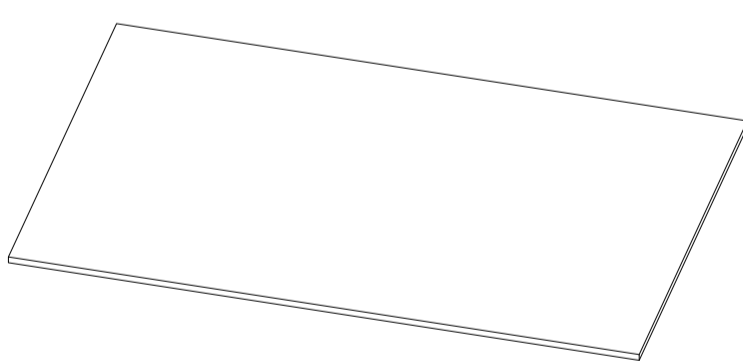
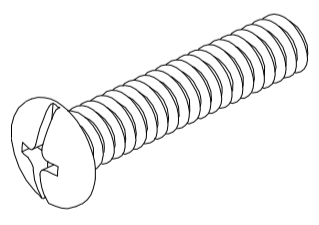
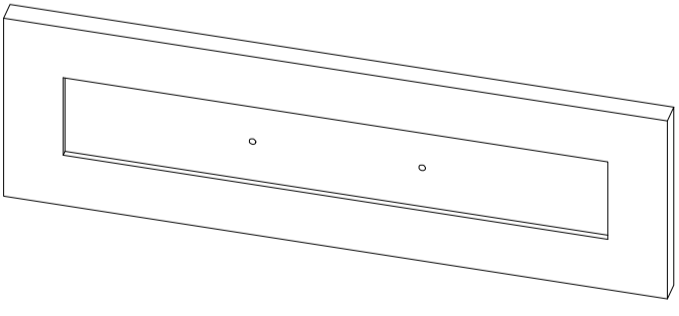
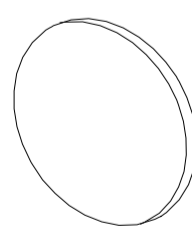
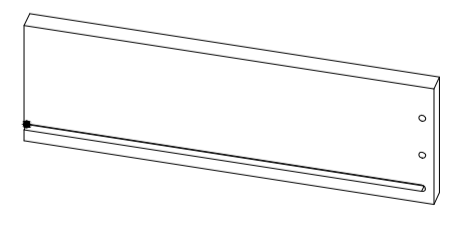
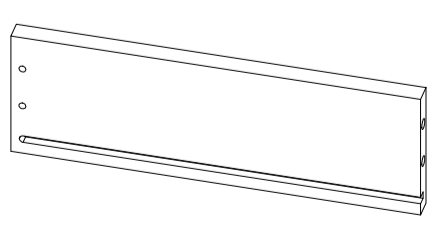
PARTS LIST			HARDWARE LIST		
No.	Description	QTY	No.	Description	QTY
1		1	A	 Three-in-one Connector	27
2		1	B	 Wood Plug	10
3		2	C	 Screws M4*14	36
4		1	D	 Slider	1
5		1			
6		1	F	 Screws M4*35	4
7		1	G	 Hinges	4
8		1	H	 Handle Screws M4x22	4
9		1	J	 Handle	3
10		1	K	 Screws For Fix On The Wall M4*35	2
11		1	L	 Handle Screws M4x16	2
12		1	M	 Cover	27
13		1			
14		1			

CAUTION: Please confirm the parts list before installtion

YOU MAY NEED (NOT SUPPLIED)

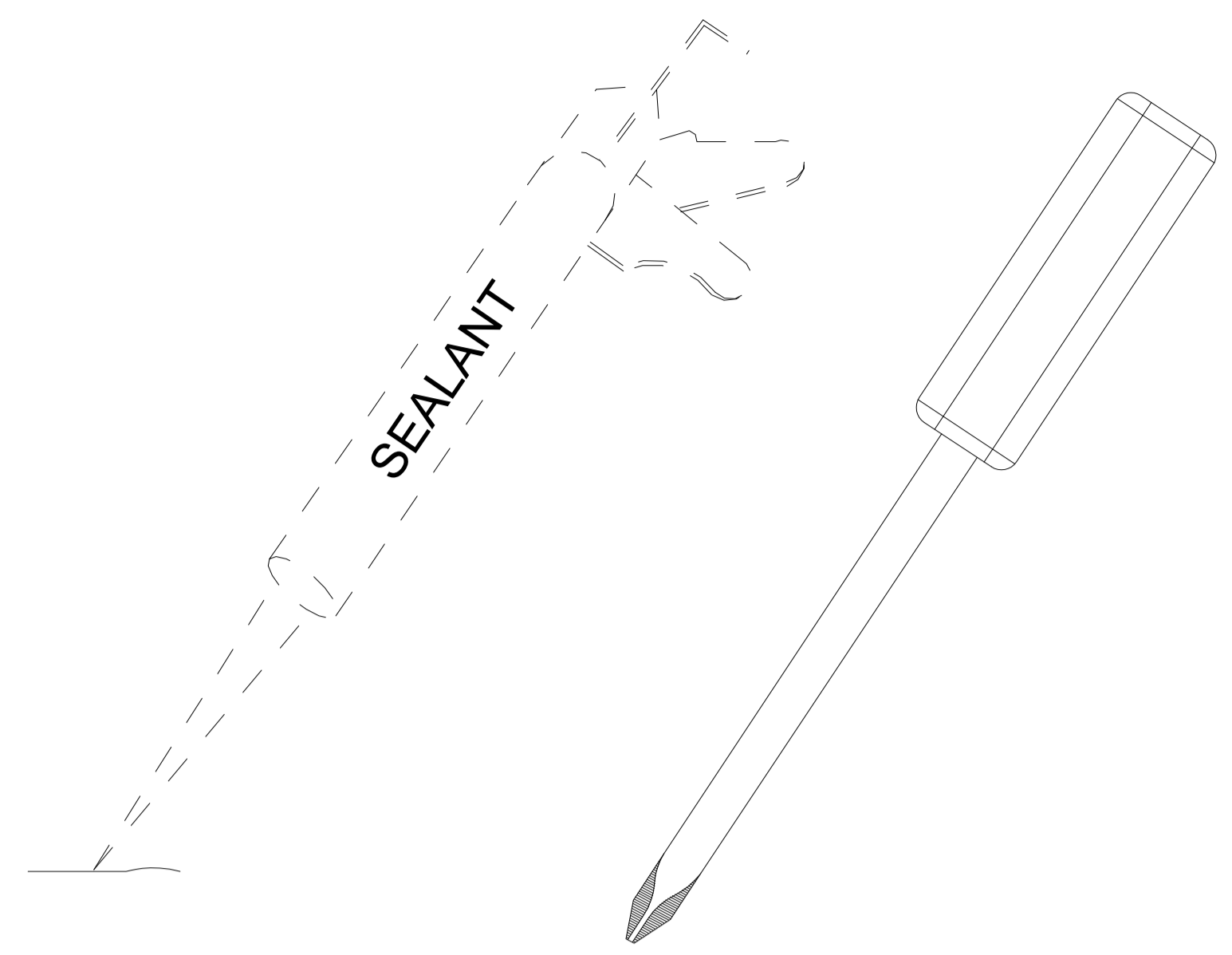
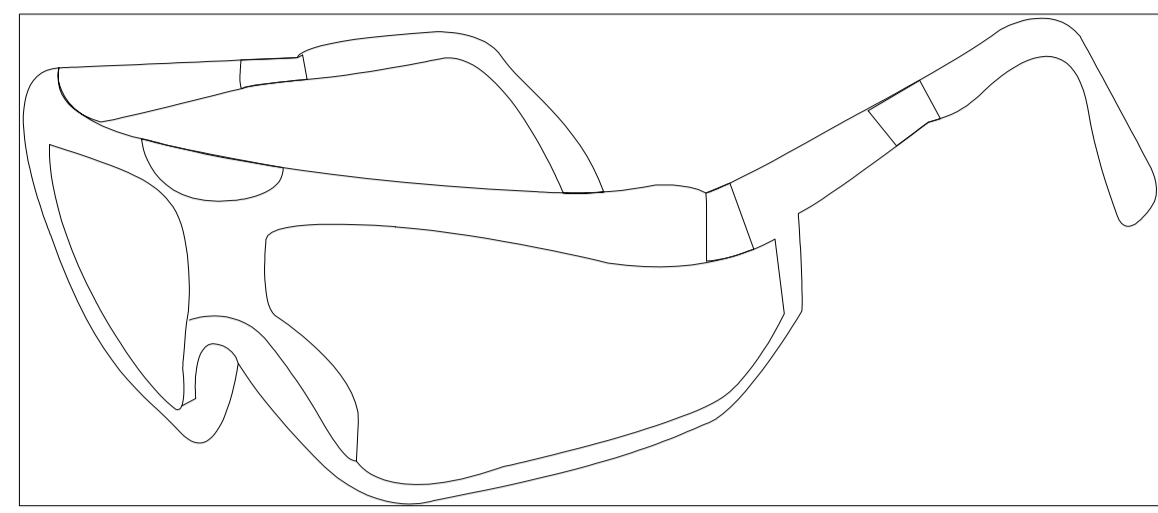
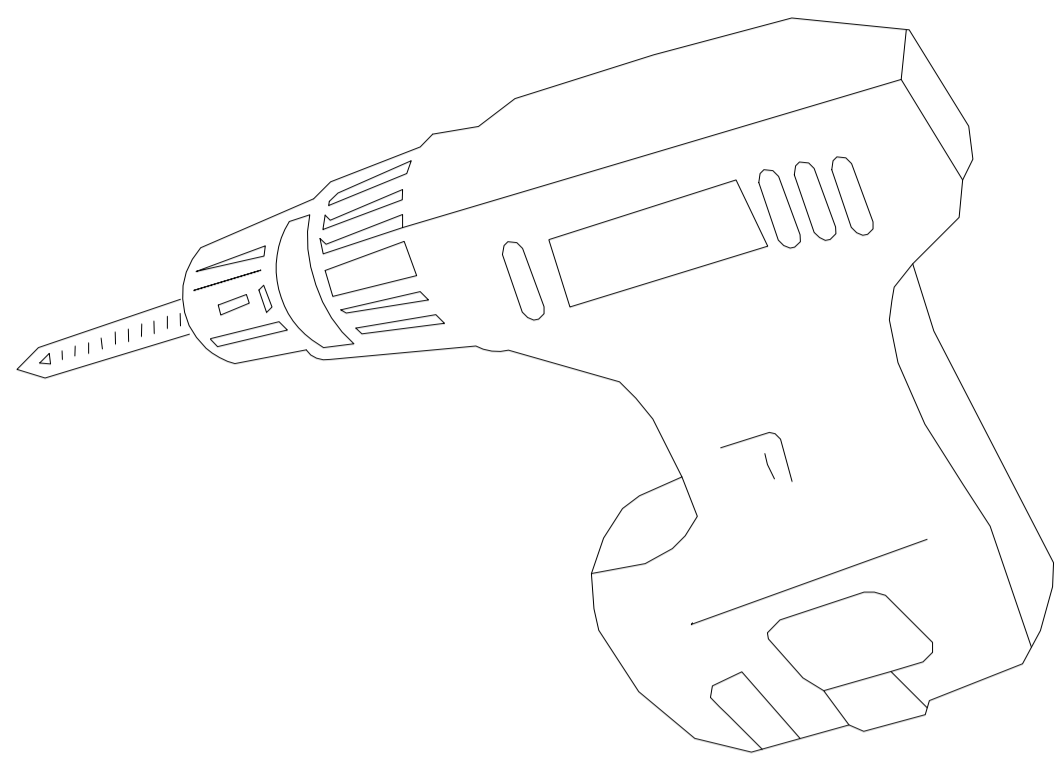

INSTALLATIONS

STEP 1

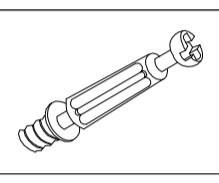
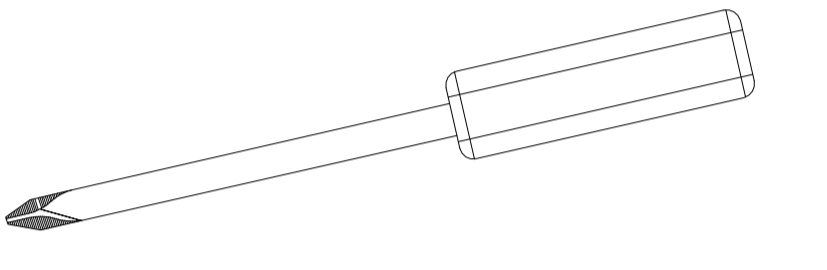
HARDWARE LIST		
A	 27PCS	

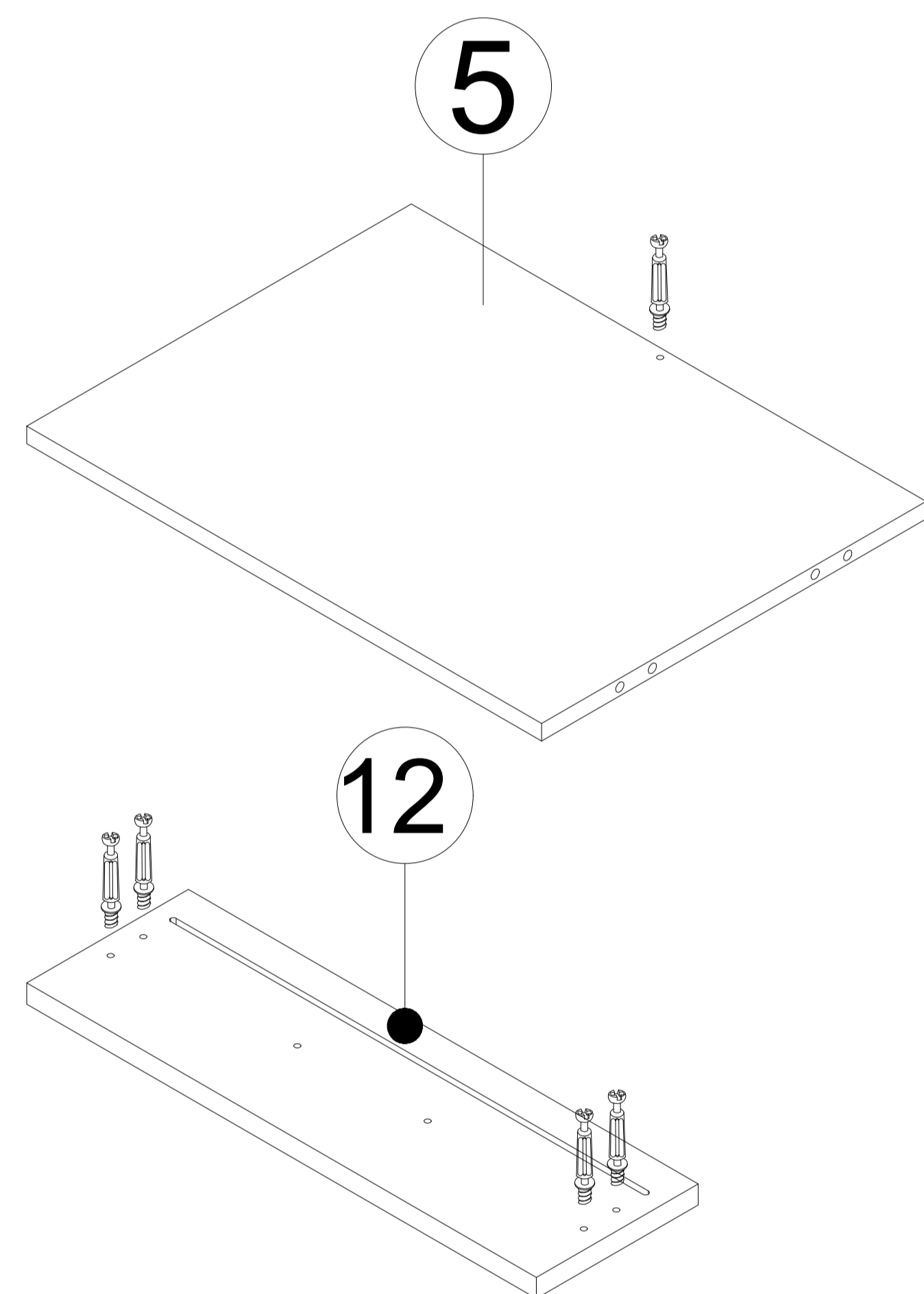
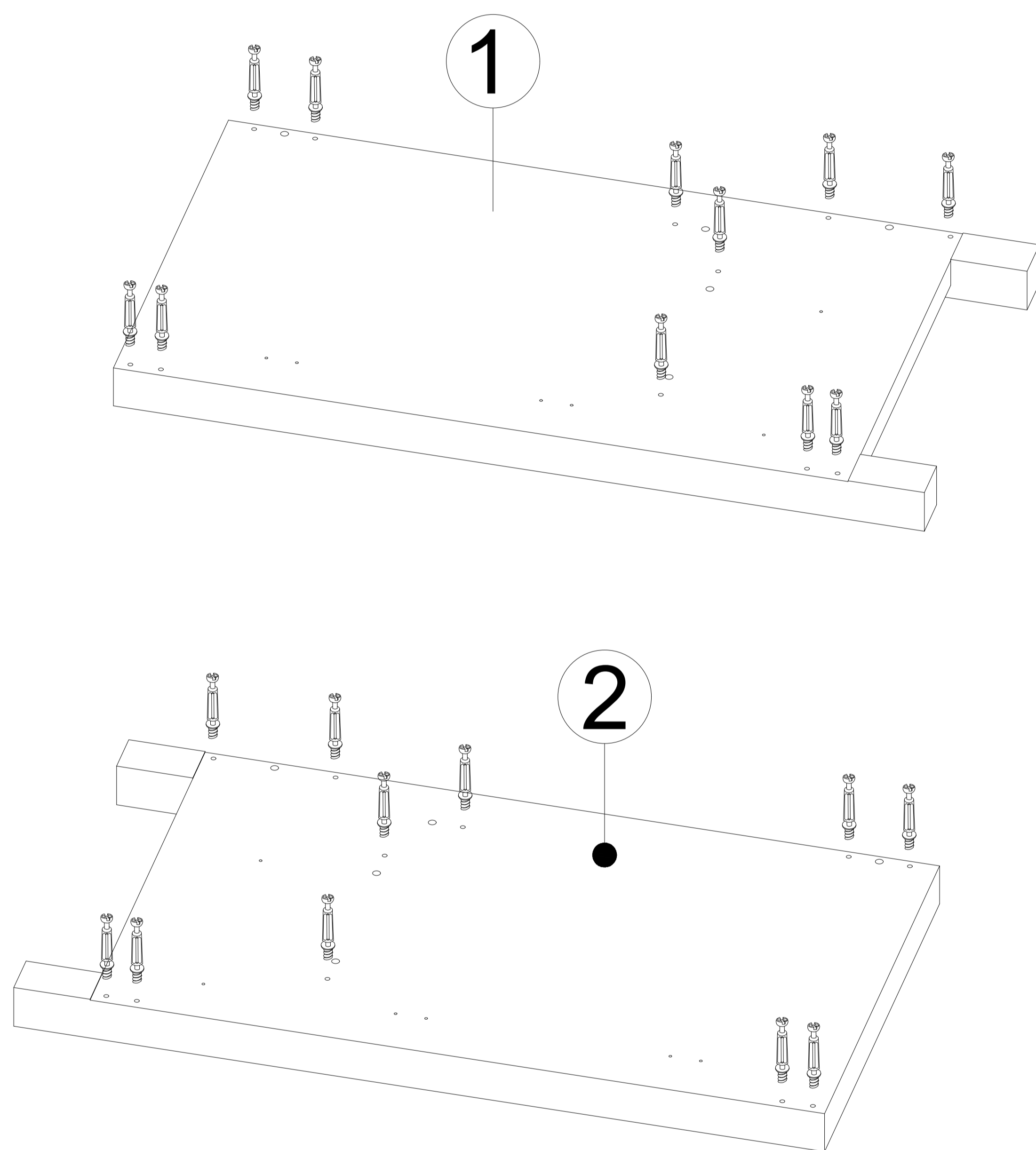
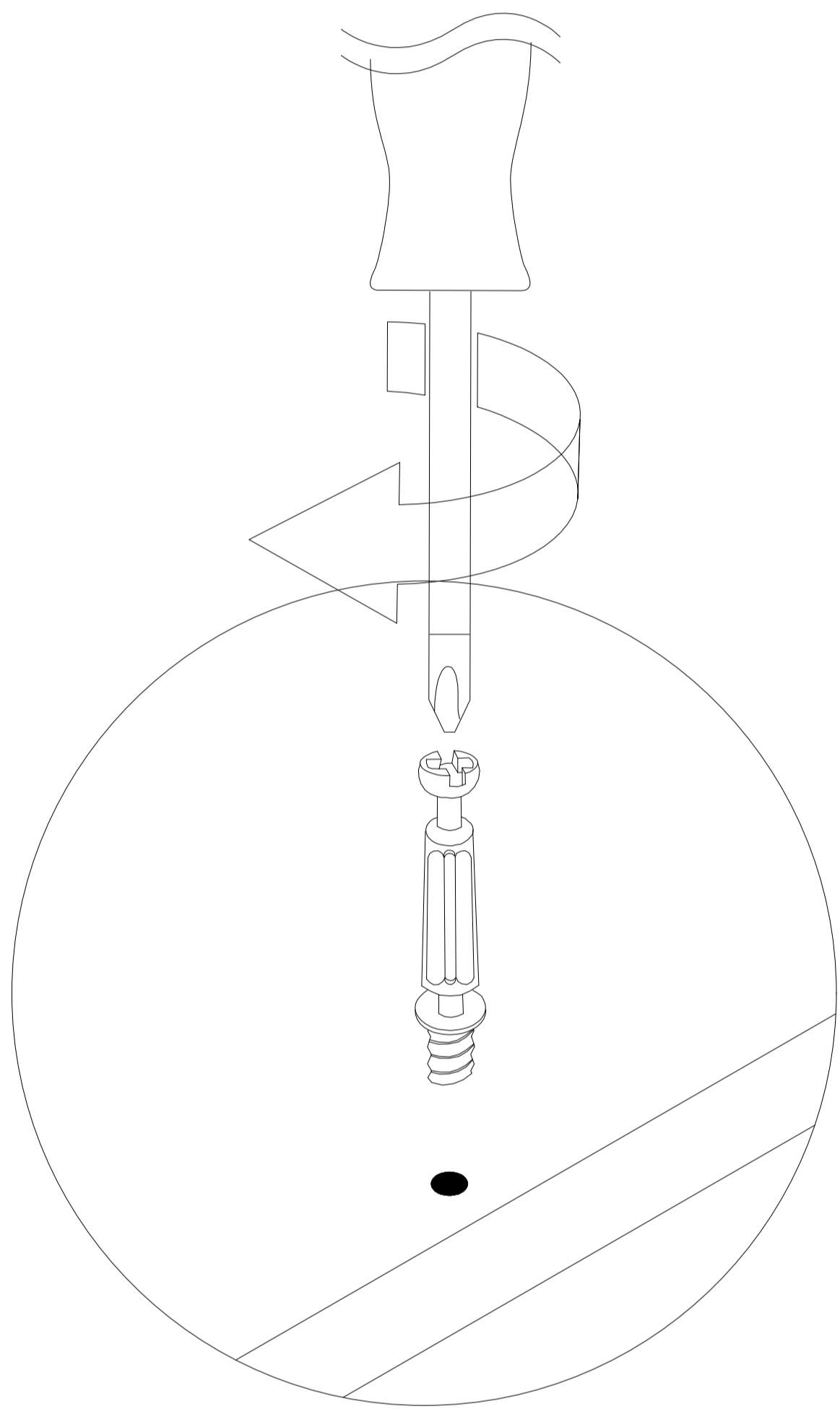

Insert the Cam Screw into the shelves above.

STEP 2

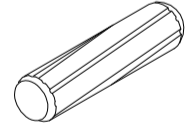
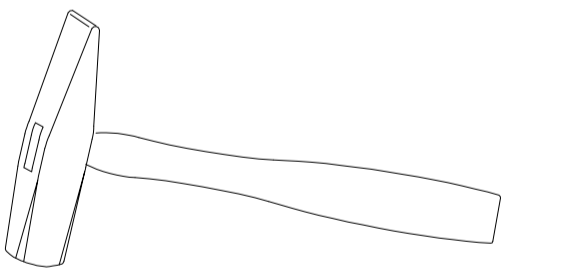
HARDWARE LIST		
B	 10PCS	

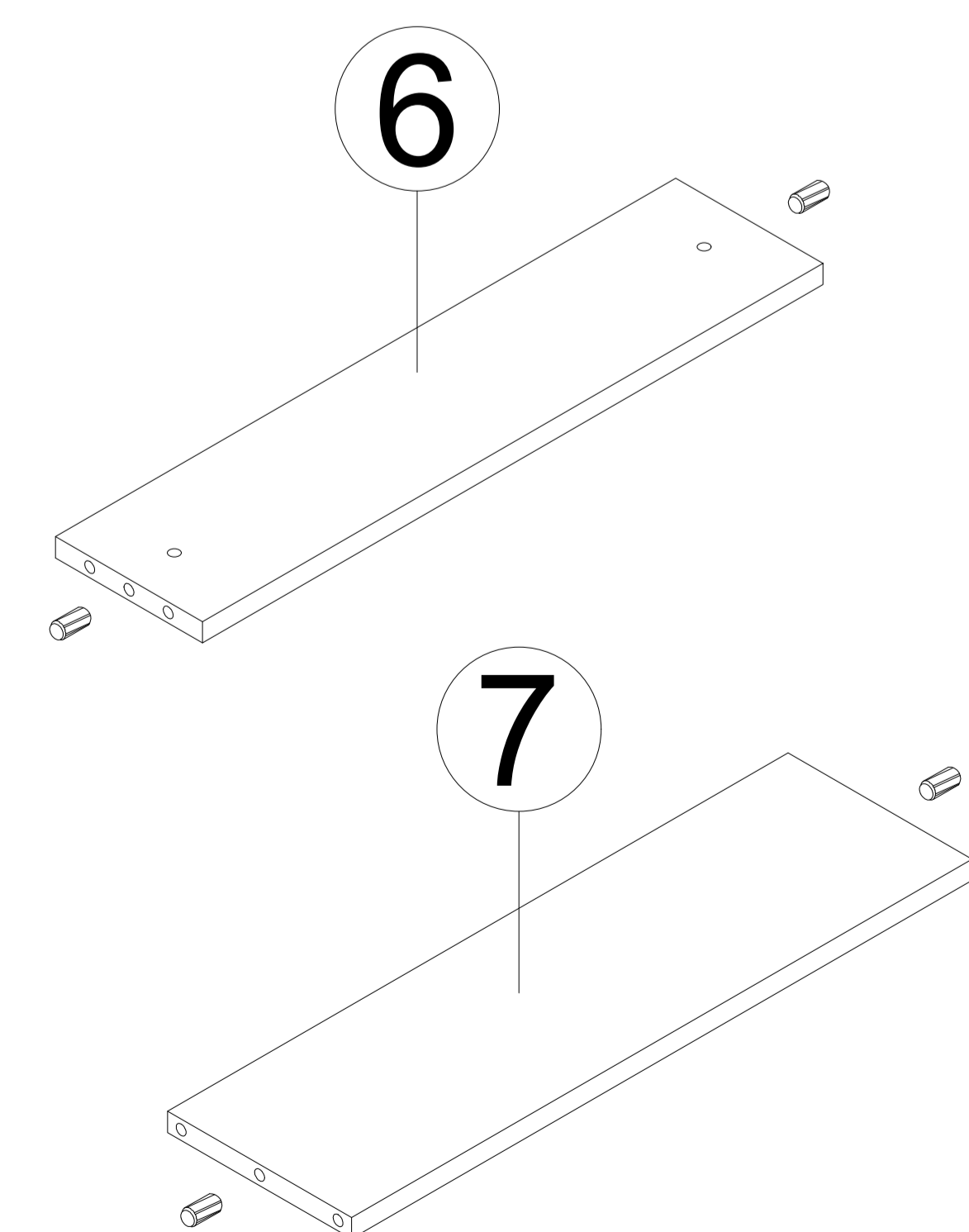
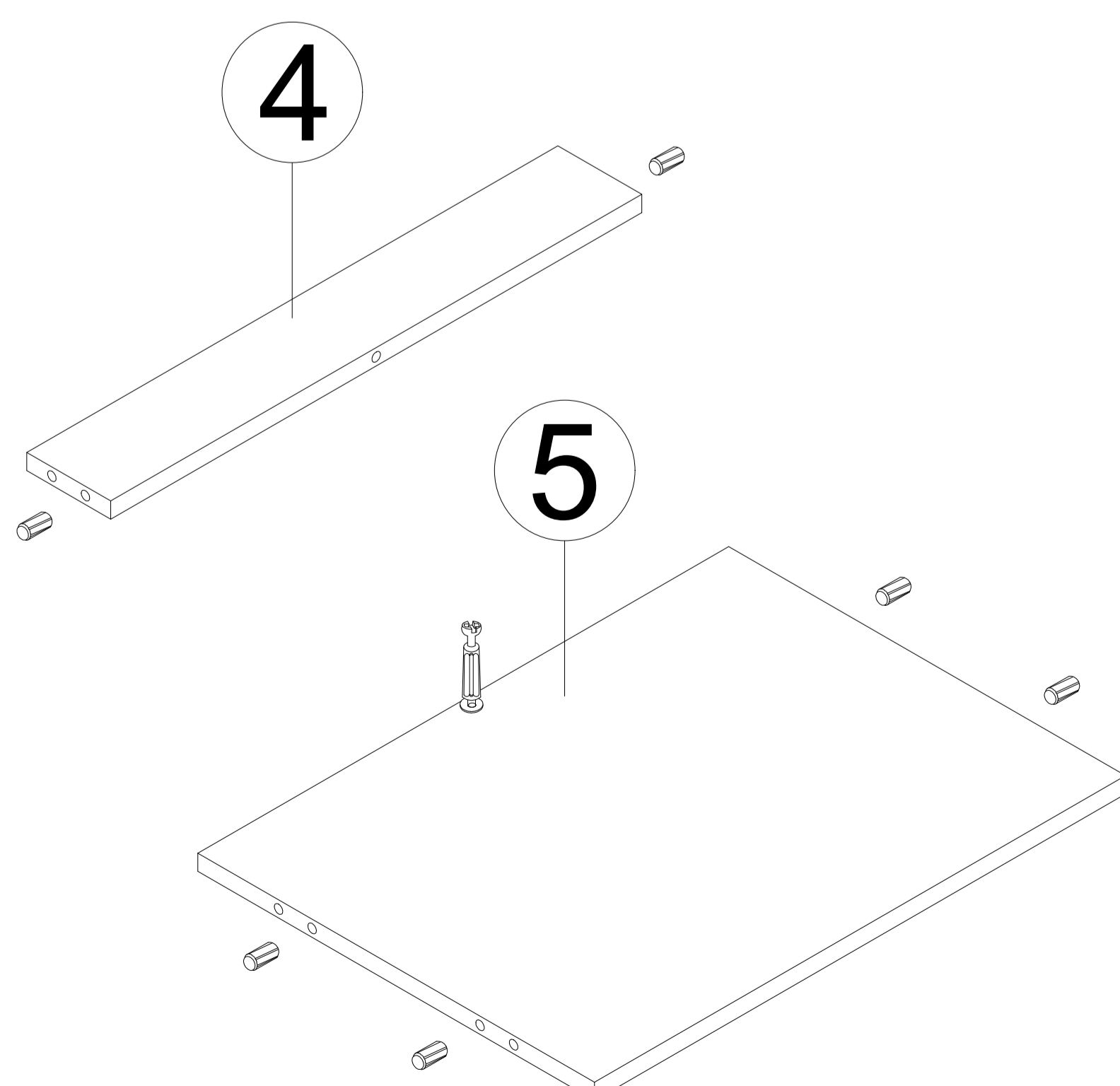
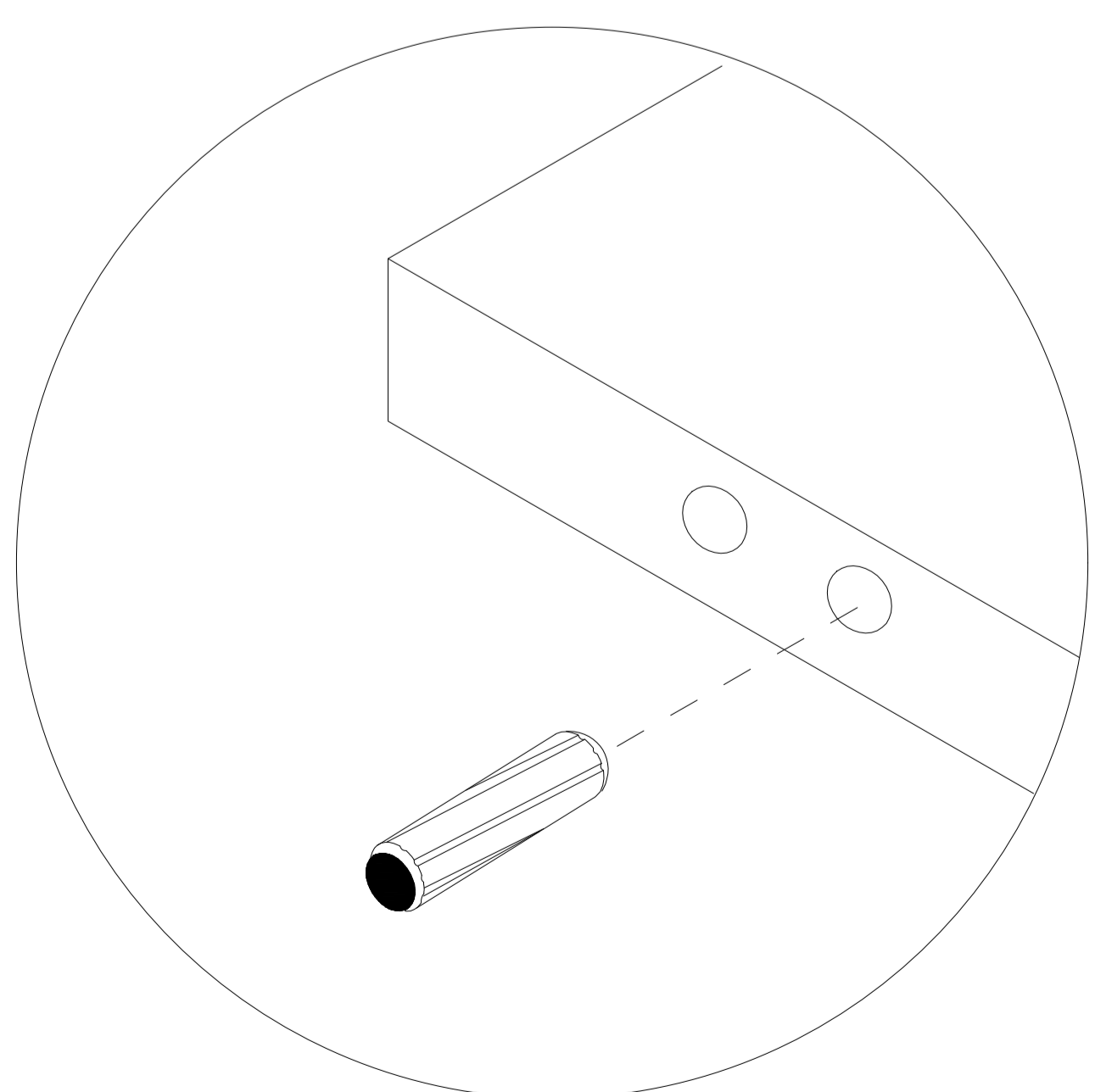

Insert the wooden dowel pins into the shelves.

STEP 3

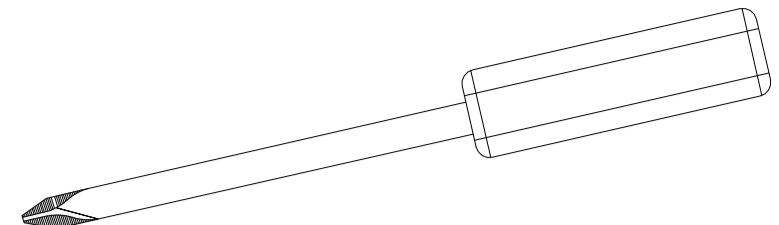
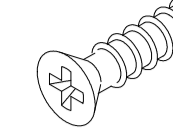
D		2PCS	
C		6PCS	

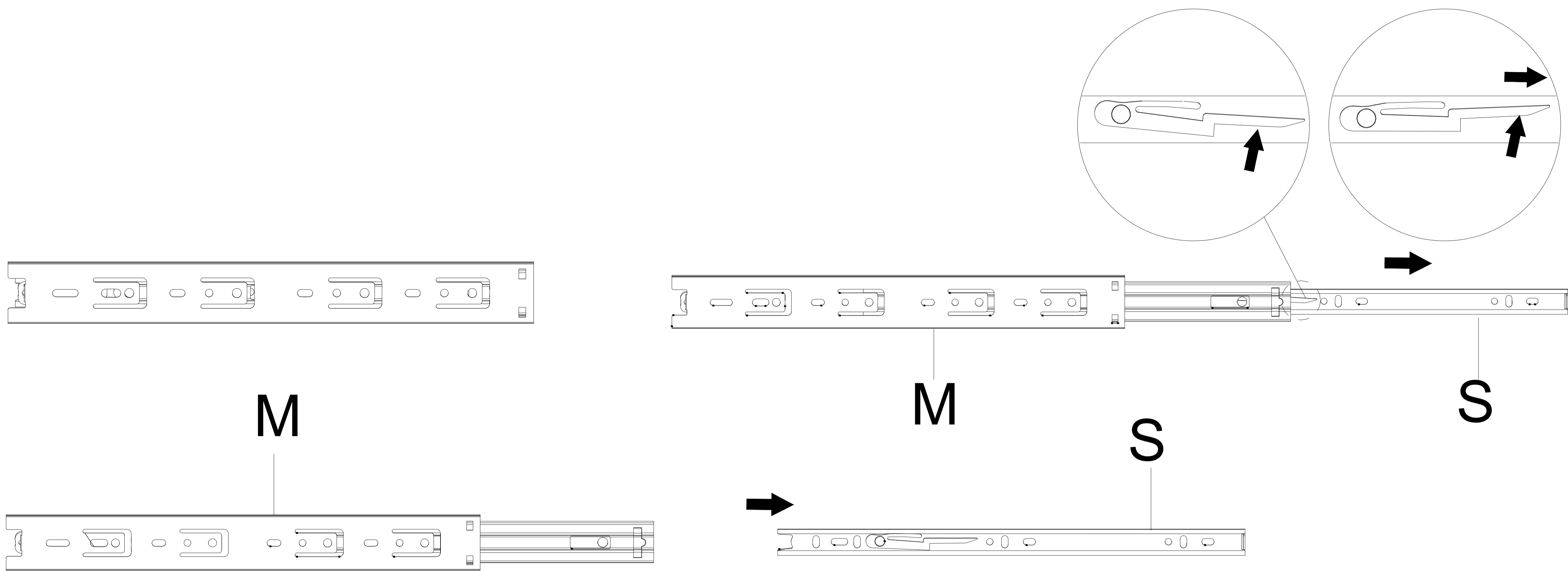

eplis eup epAep o4 jno lind ueup'evey fupssesd deey

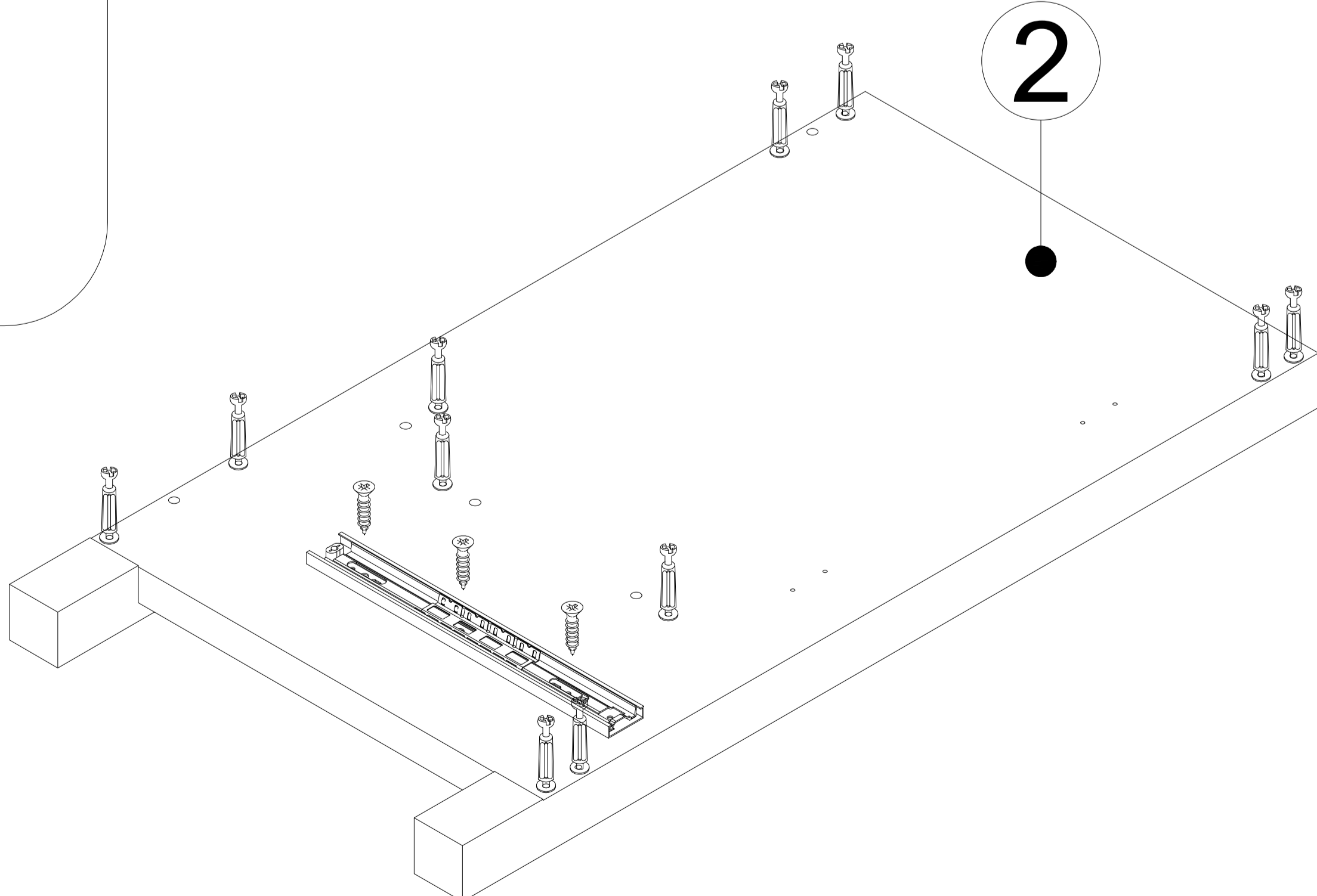
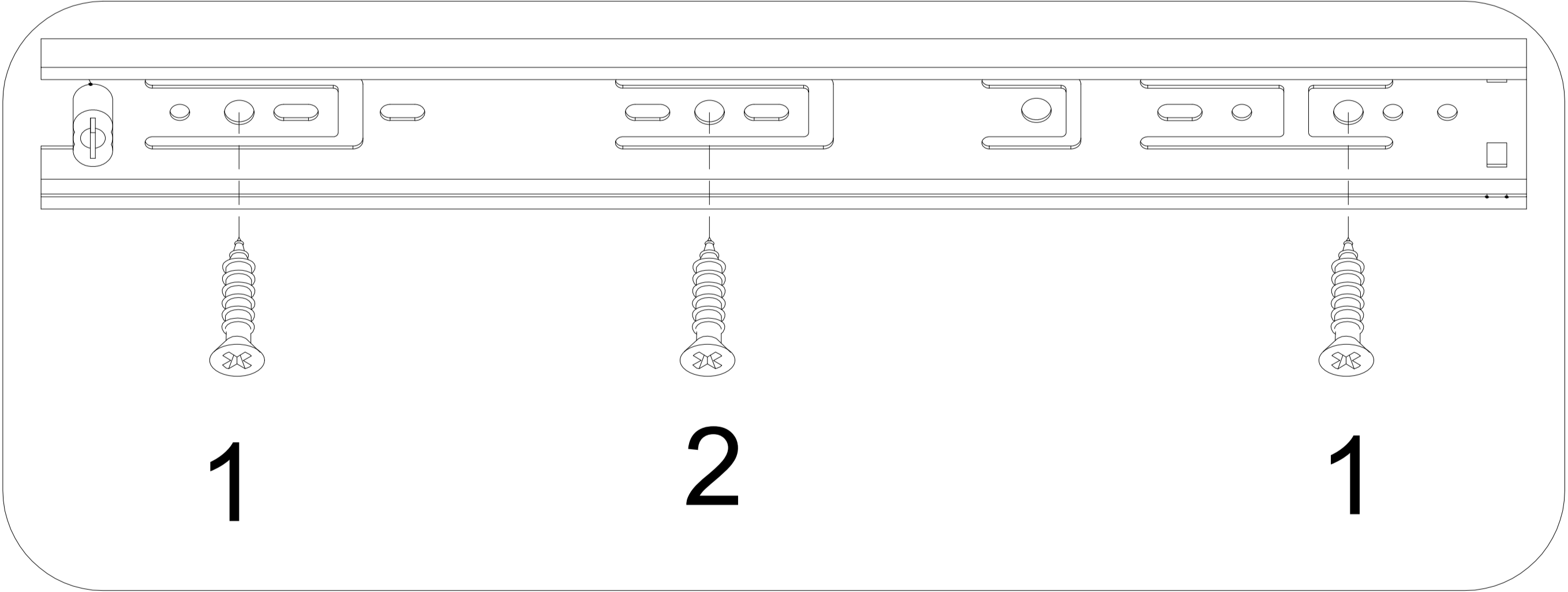
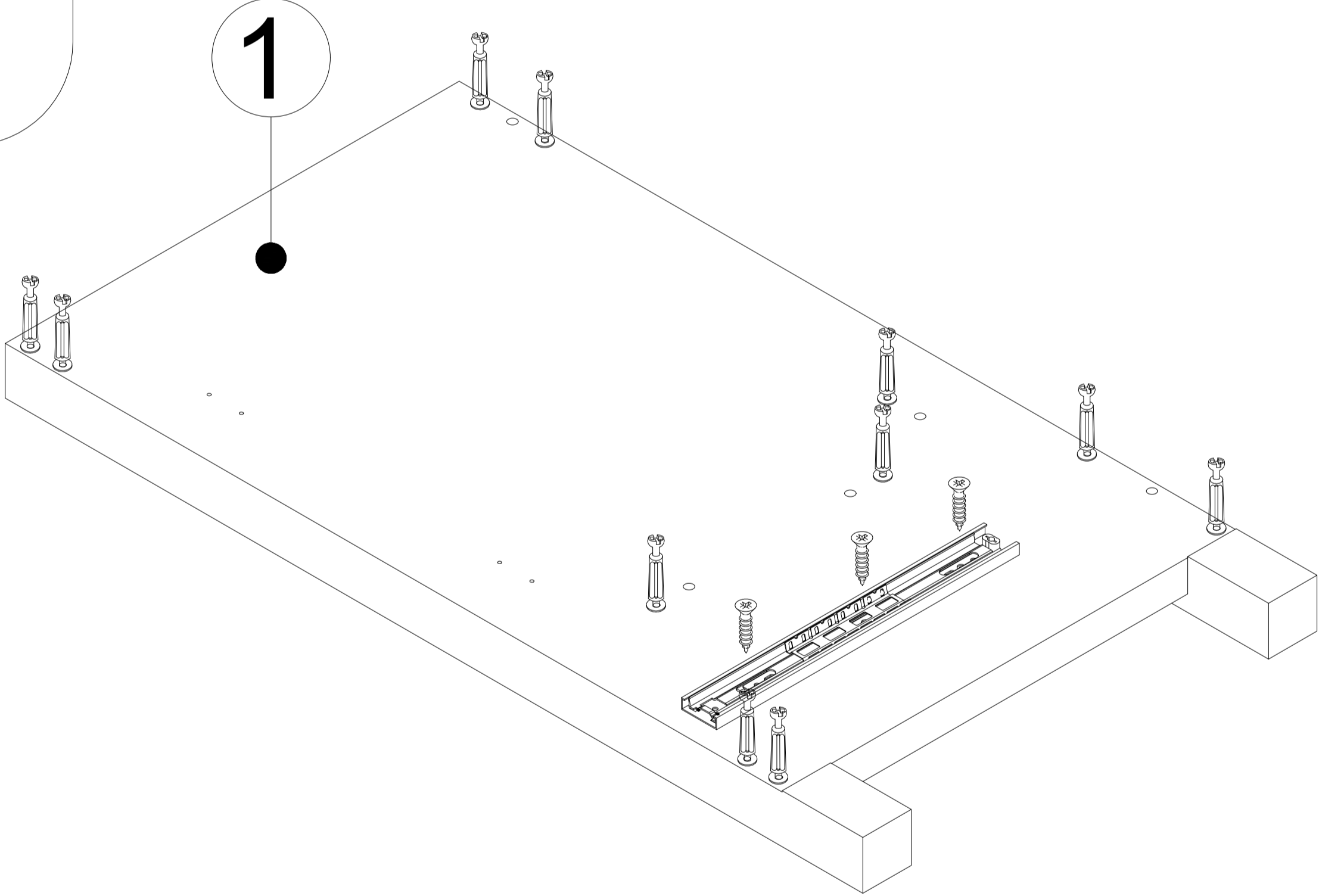
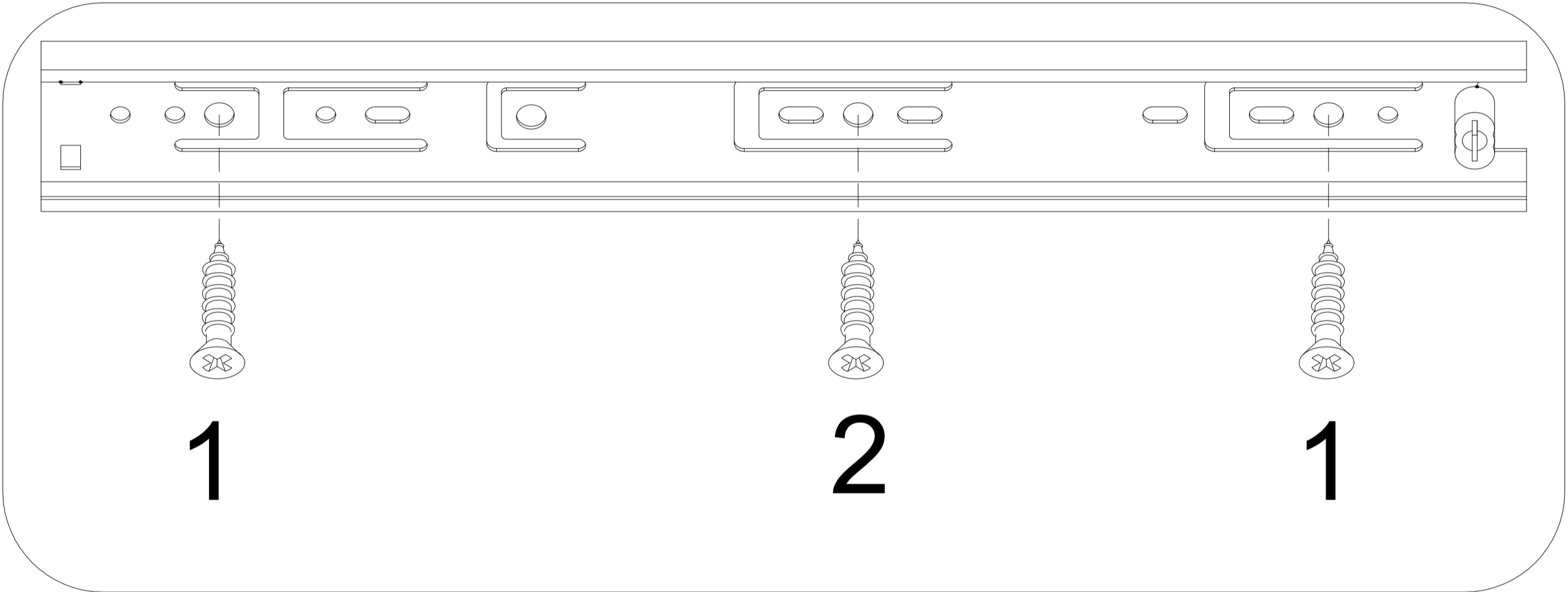

- Refer to the illustration to fix the Slide rails to the board #1 and #2 with screws.

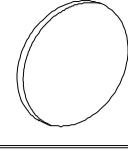
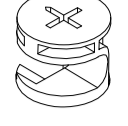

STEP 4

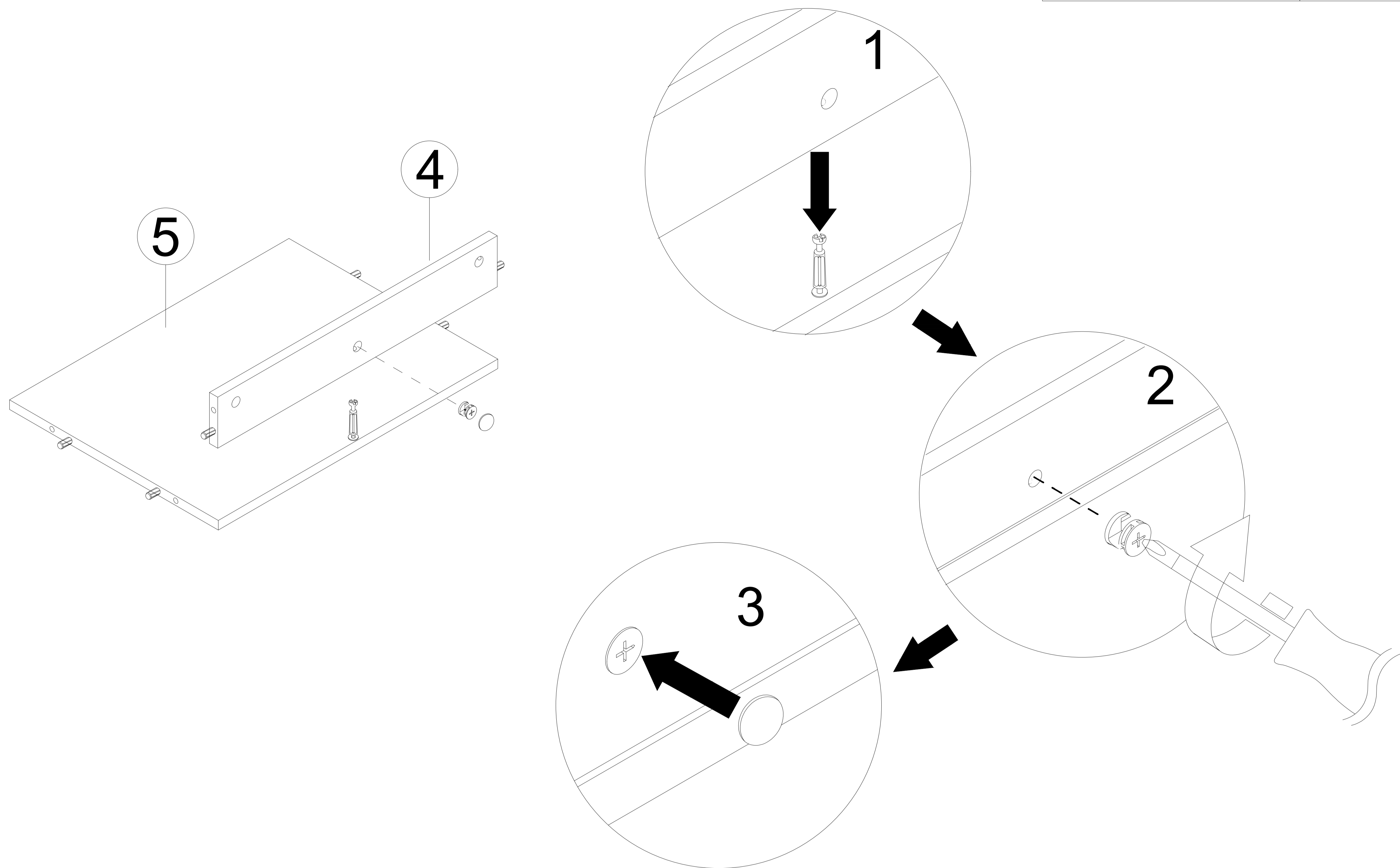
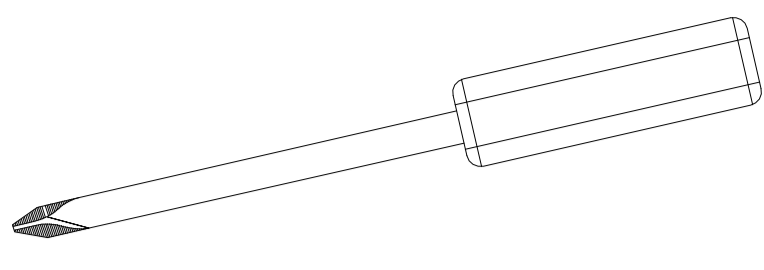
HARDWARE LIST		
M		1PCS
A		1PCS

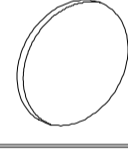

- Insert shelves #4 and #5 downwards to their corresponding positions. Then tighten the cam lock with the cover.

STEP 5

HARDWARE LIST		
M		11PCS
A		11PCS

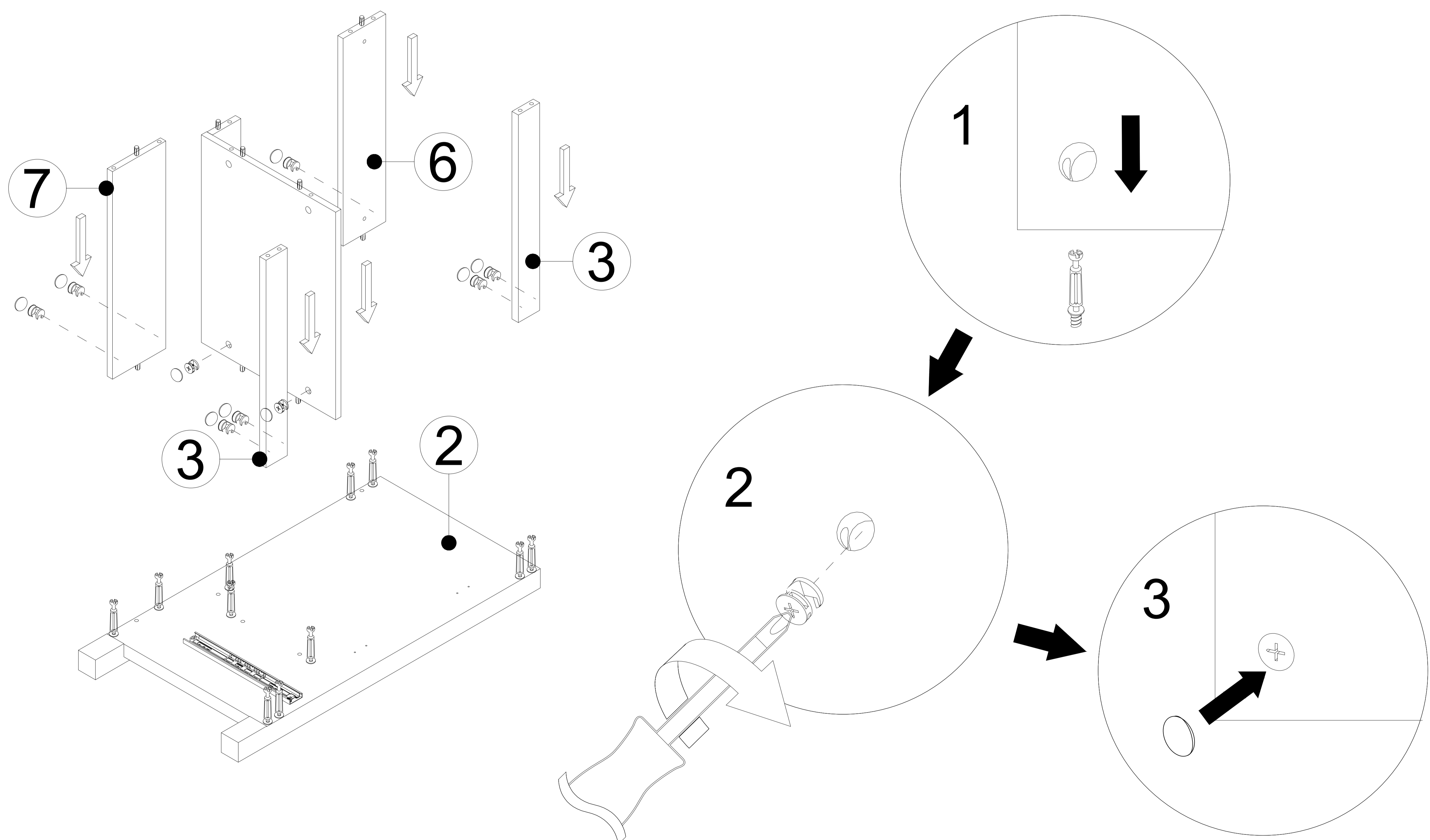
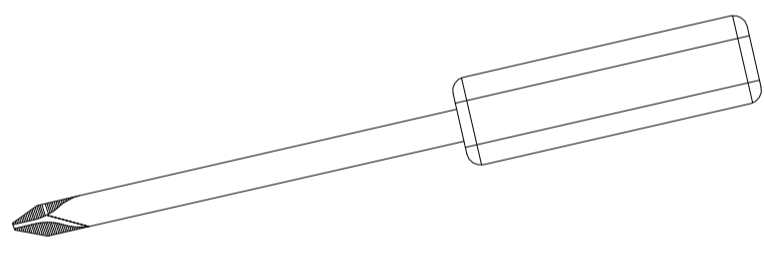

- Refer to the illustration, insert the shelves #3, #6, #7 and already assembled #4, #5 on the shelf #2. Then tighten the cam lock with the cover..

STEP 6

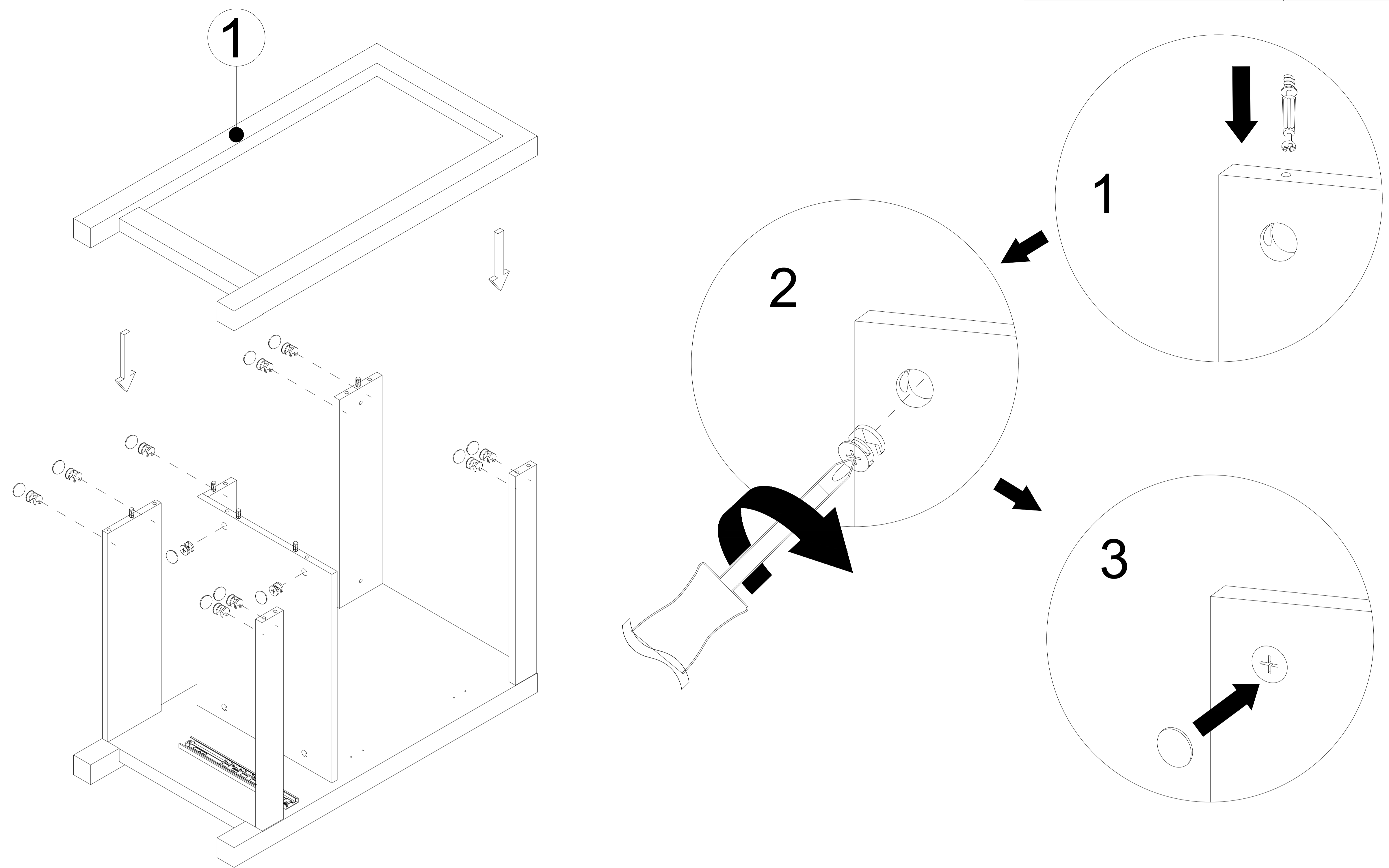

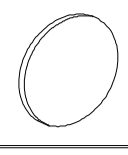
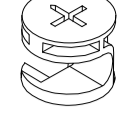
HARDWARE LIST		
M		11PCS
A		11PCS

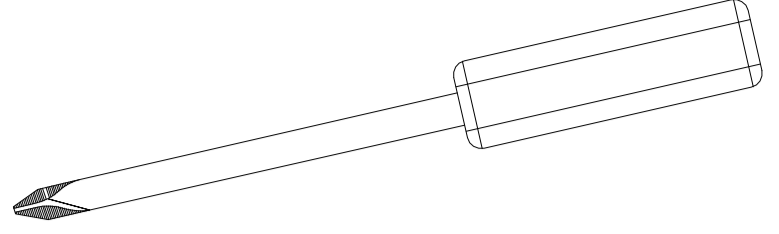

- Refer to the illustration, Install shelf #1 on the cabinet. Then tighten the cam lock with the cover.

STEP 7

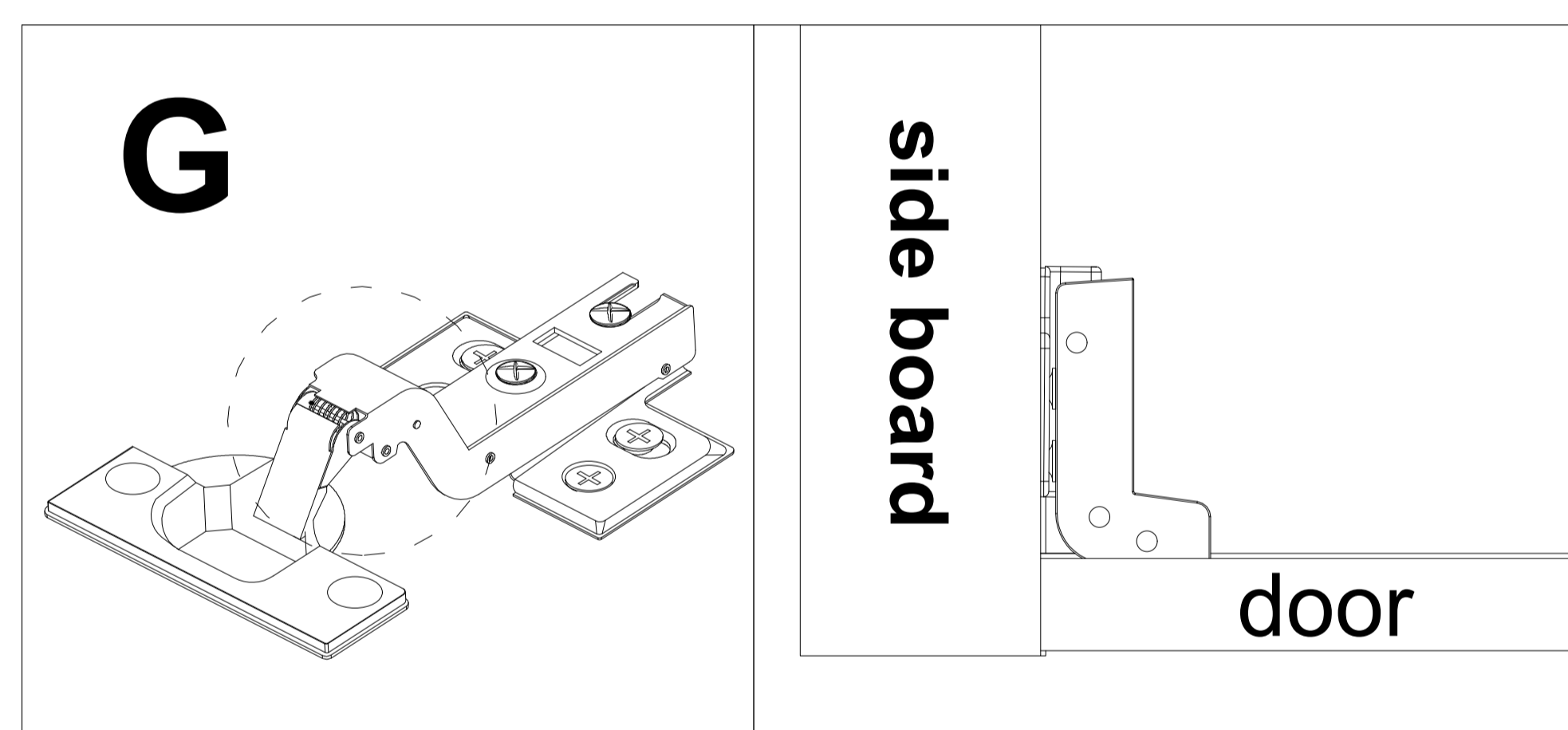

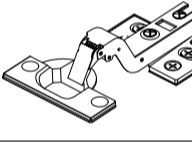
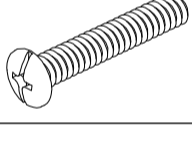
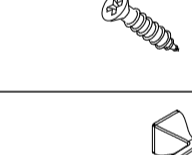
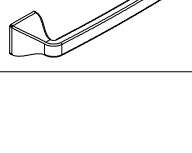
HARDWARE LIST		
G		4PCS
H		4PCS
C		24PCS
J		2PCS

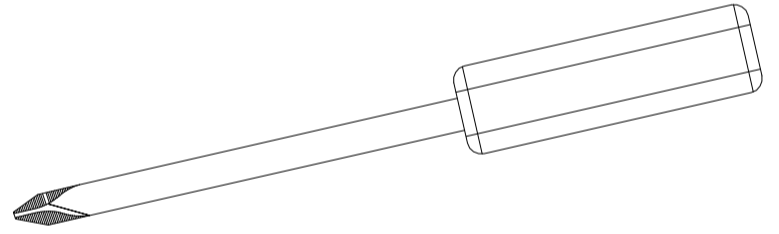
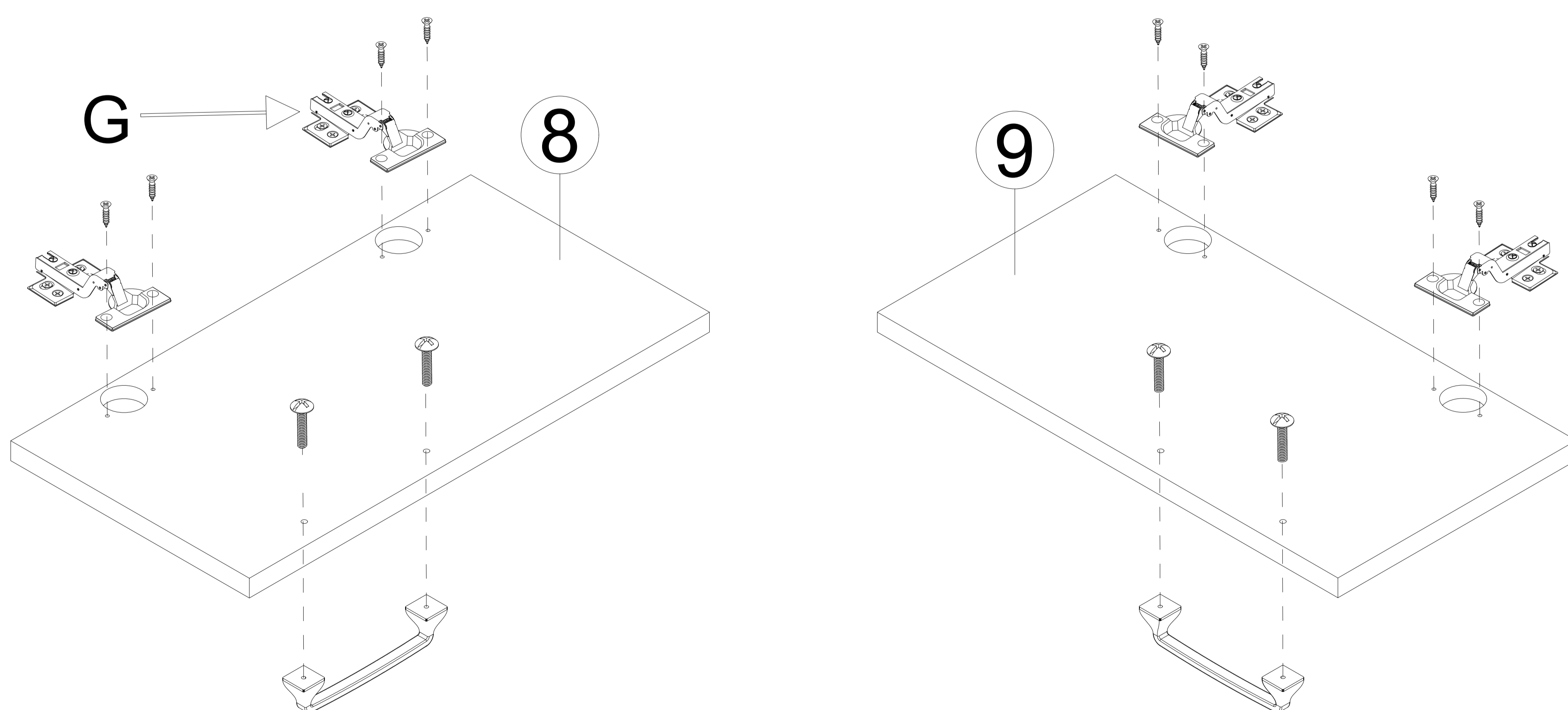
Note: see step 8 to adjust the door's position.

Use Screws to install the handle and apply Screws to fix the hinge on the shelf #8. Then use Screws to connect the hinge bracket to the cabinet. Repeat these steps for the other door.

STEP 8

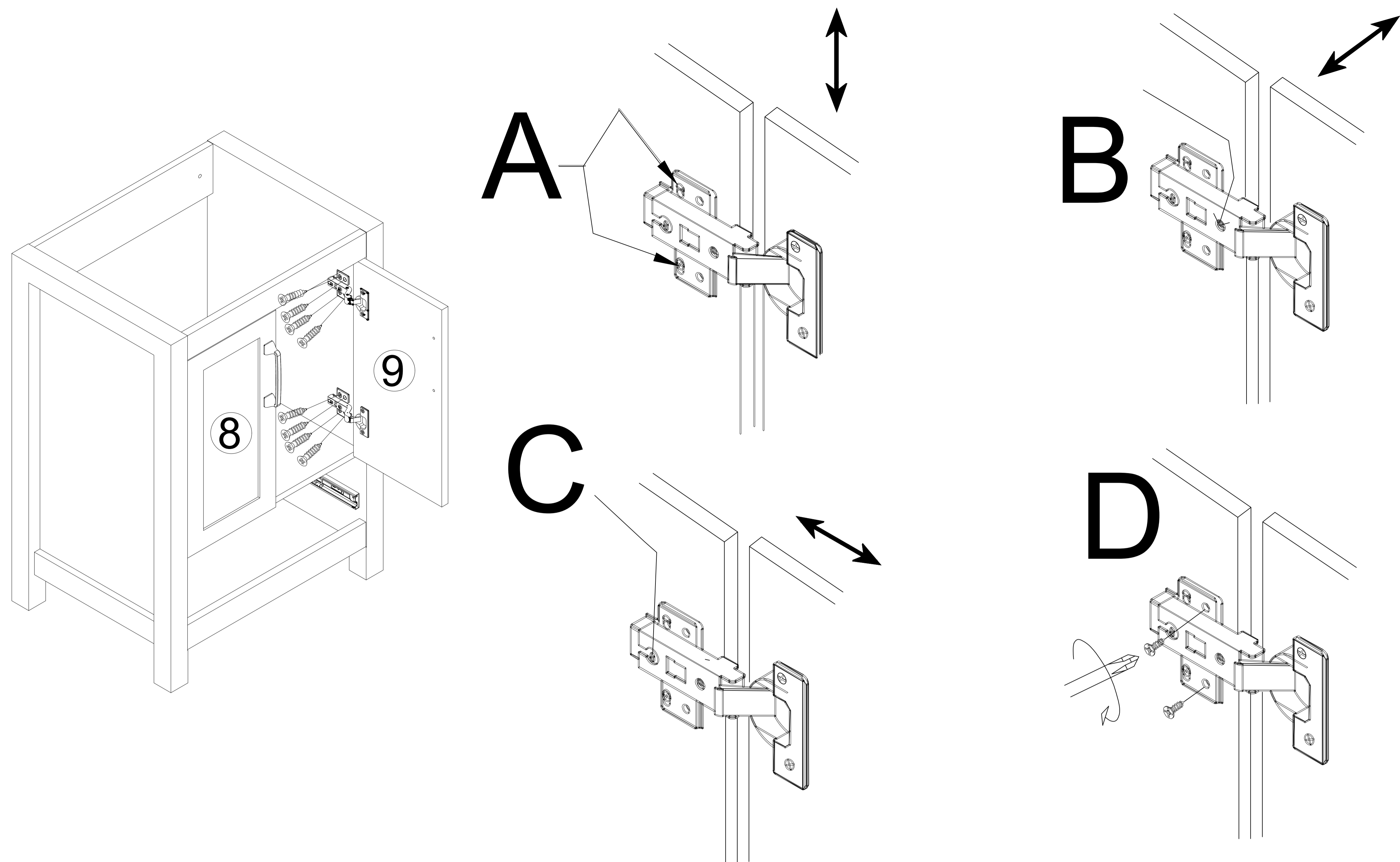

A.Height adjustment B.Side to side adjustment
C.Depth adjustment D.After adjustment A/B/C,tighten screws.

To ensure proper cabinet alignment, refer to the above illustrations for instructions about adjusting the cabinet height, depth and lateral movement.

STEP 9

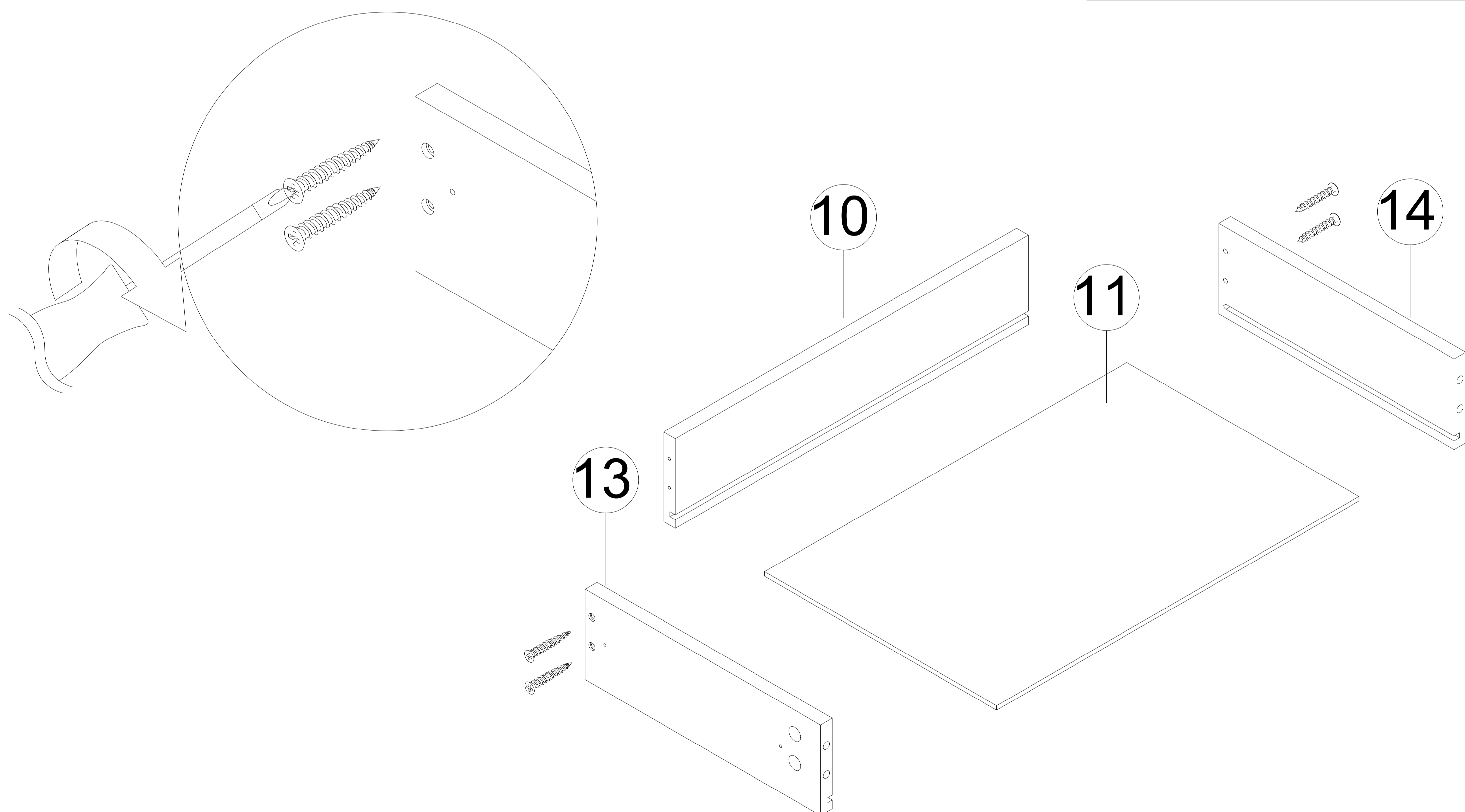

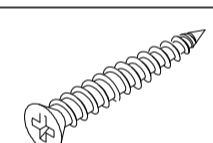
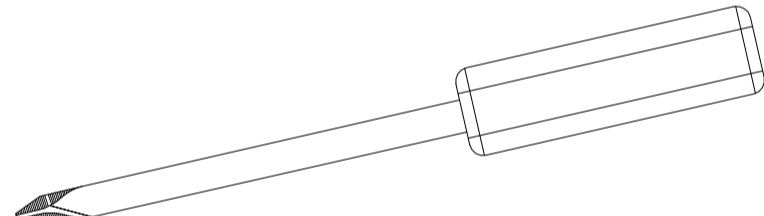
HARDWARE LIST		
F		4PCS
		

- Refer to the illustration, Connect the side plate #13, #14 with the back plate #10 with screws. Then insert the plate #11 into the finished shelf.

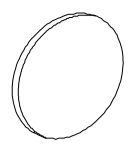
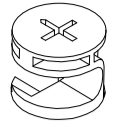

STEP 10

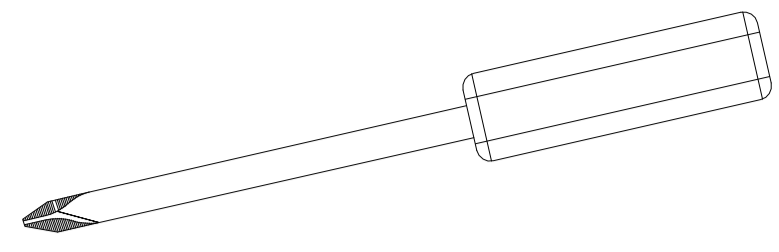
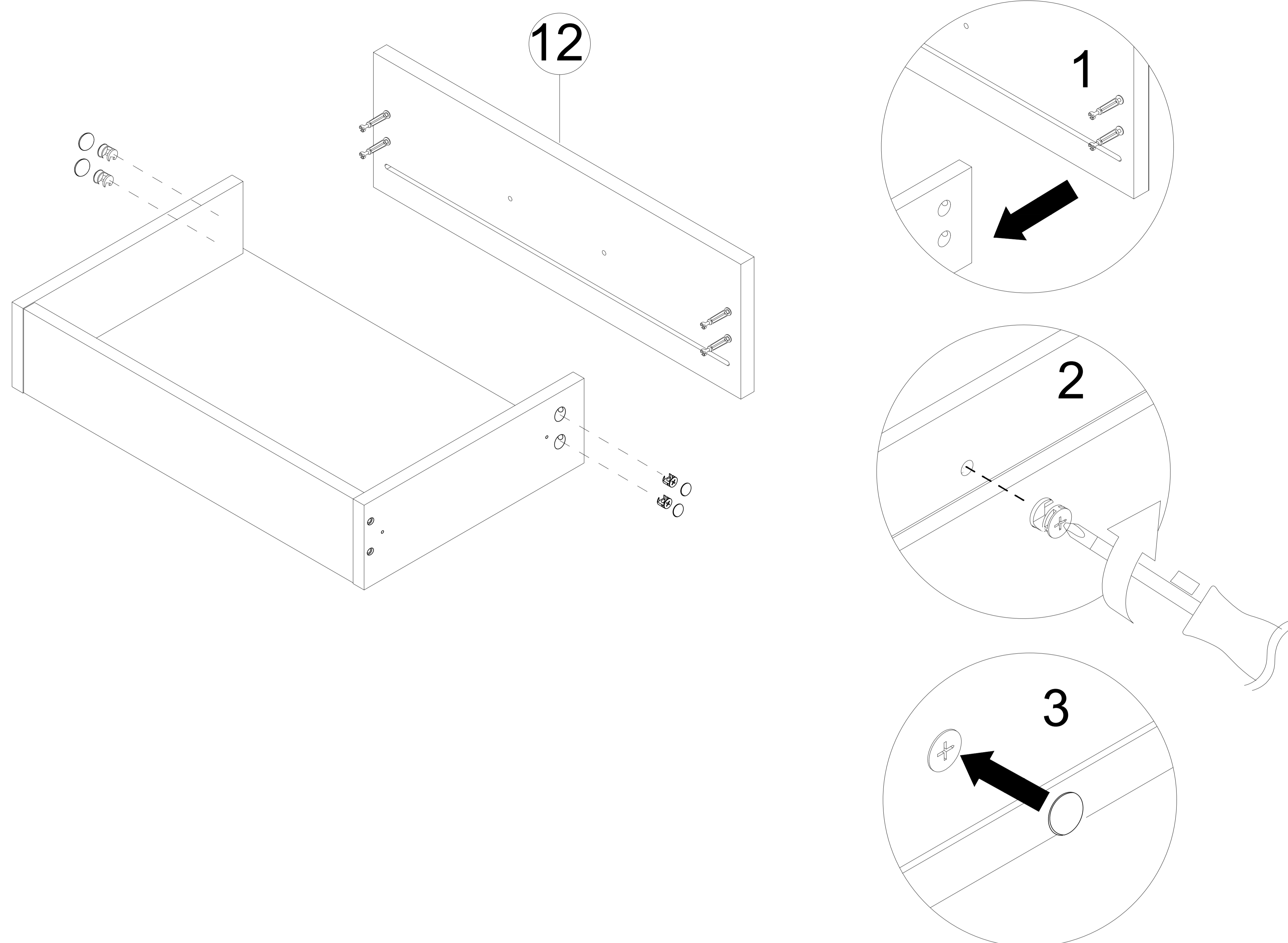
HARDWARE LIST		
M		4PCS
A		4PCS

● Refer to the illustration, Draw the panel #12 is inserted into the prepared plate, Then tighten the cam lock with the cover.

STEP 11

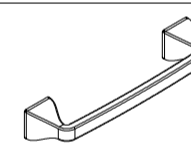
HARDWARE LIST		
J		1PCS
D		2PCS
C		6PCS
L		2PCS

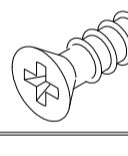
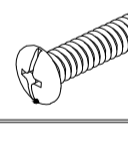
Refer to the illustration, Apply Screws to fix the slides on the boards #13,#14. to install the handle.

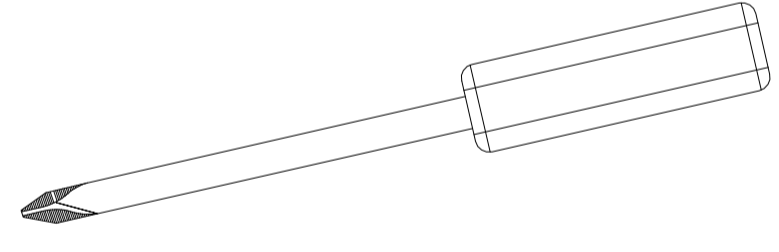
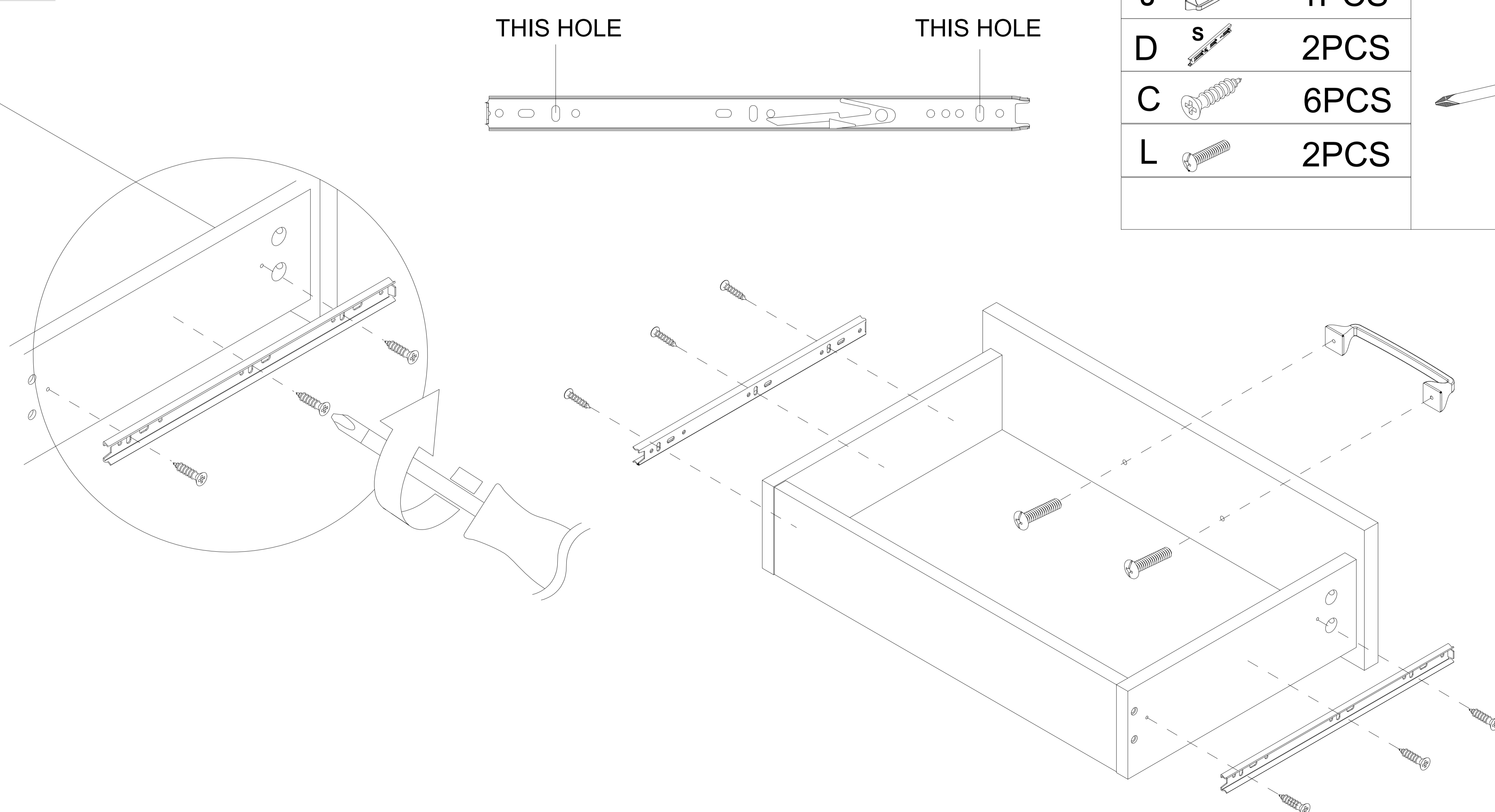

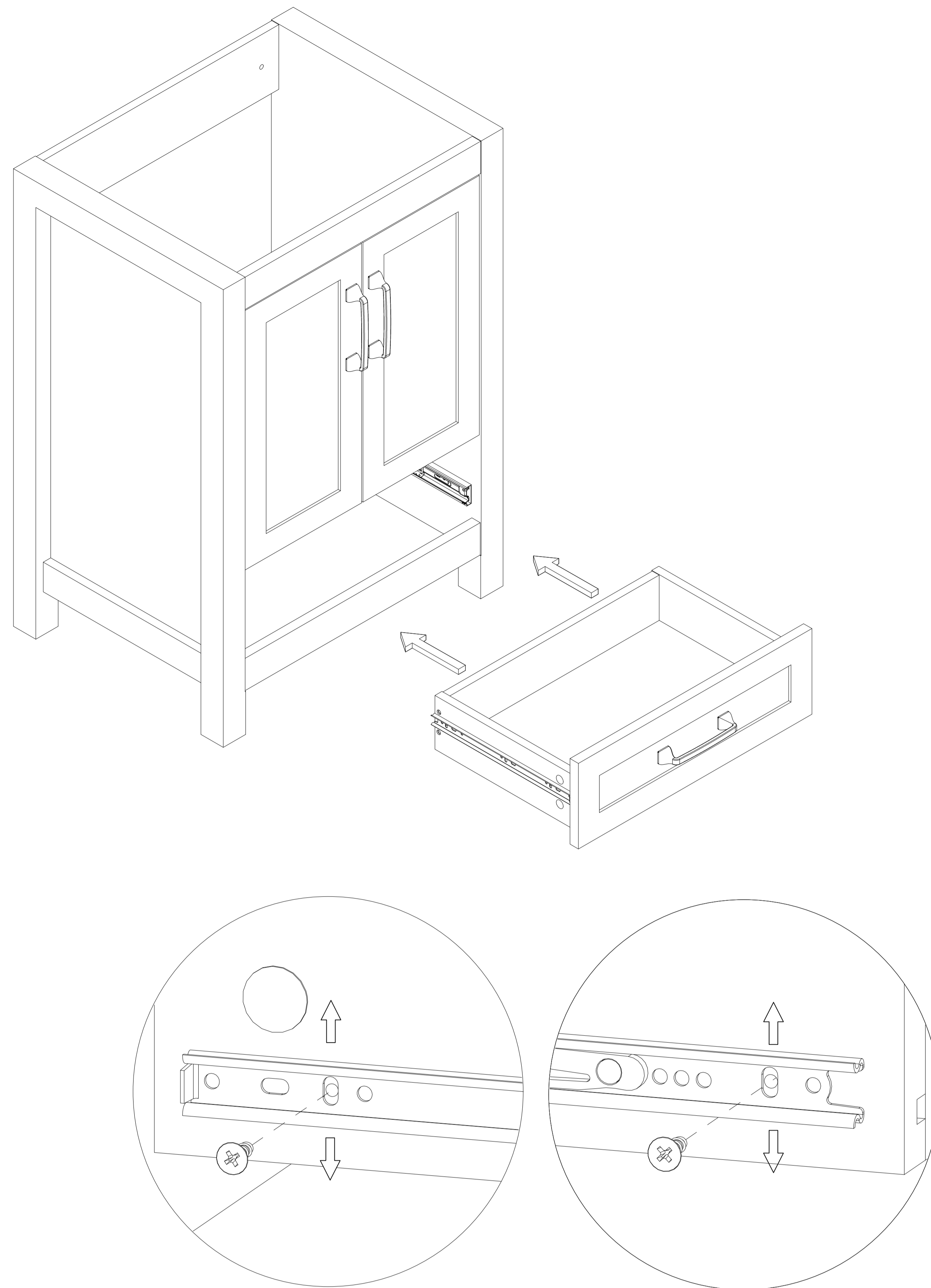

STEP 12

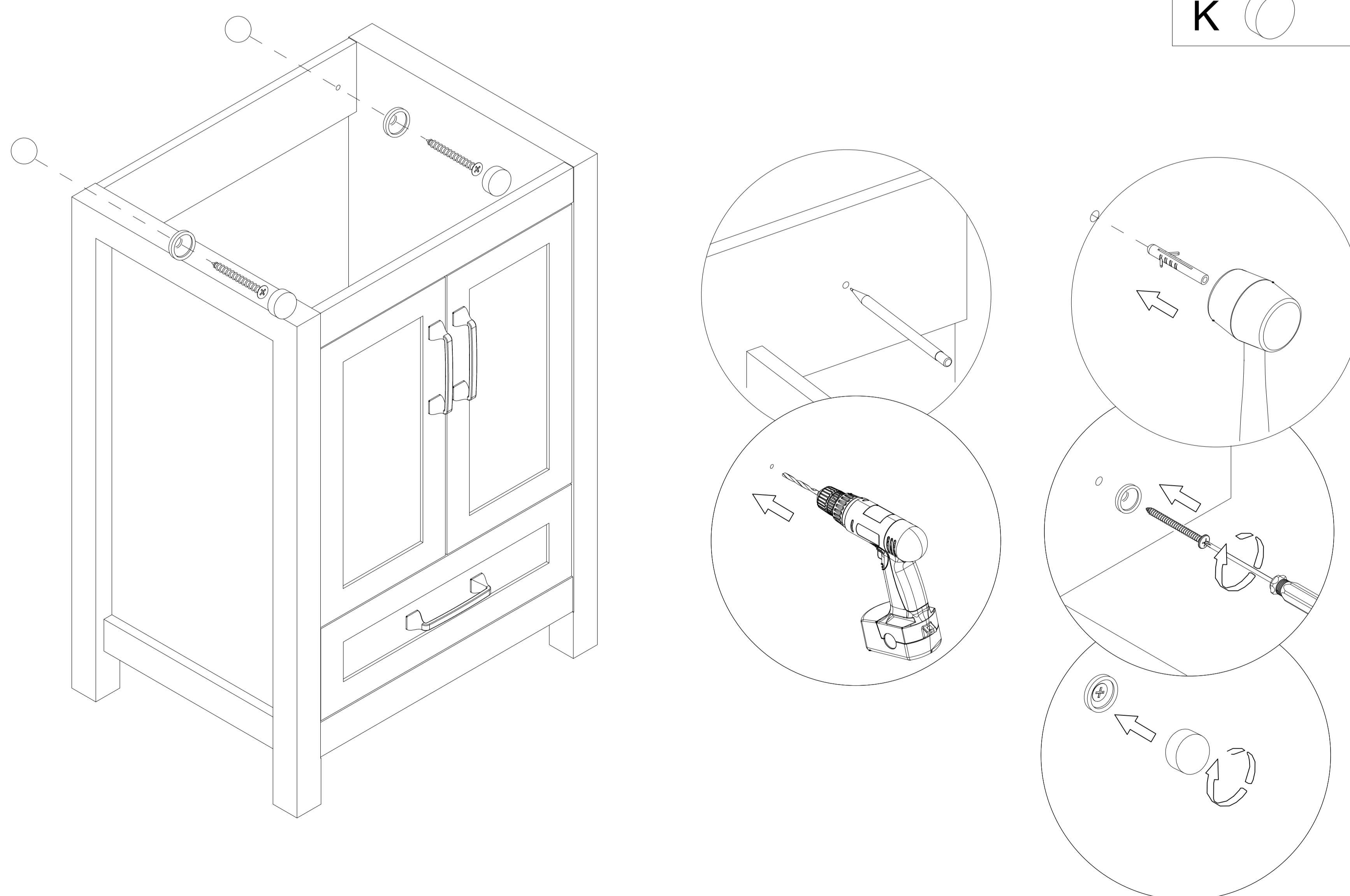

If the drawers are not in the same level, please adjust the screws in the drawer box.
Assembled drawers are loaded onto cabinets.

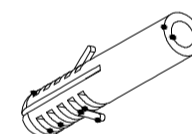
STEP 13

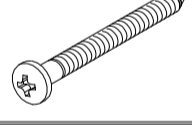

HARDWARE LIST		
K		2PCS
K		2PCS
K		2PCS
K		2PCS

Refer to the illustration, Draw the spacing between the walls on the cabinet, punch holes in the wall, and fix the cabinet to the wall with screws. Then tighten the nut cover.

STEP 14

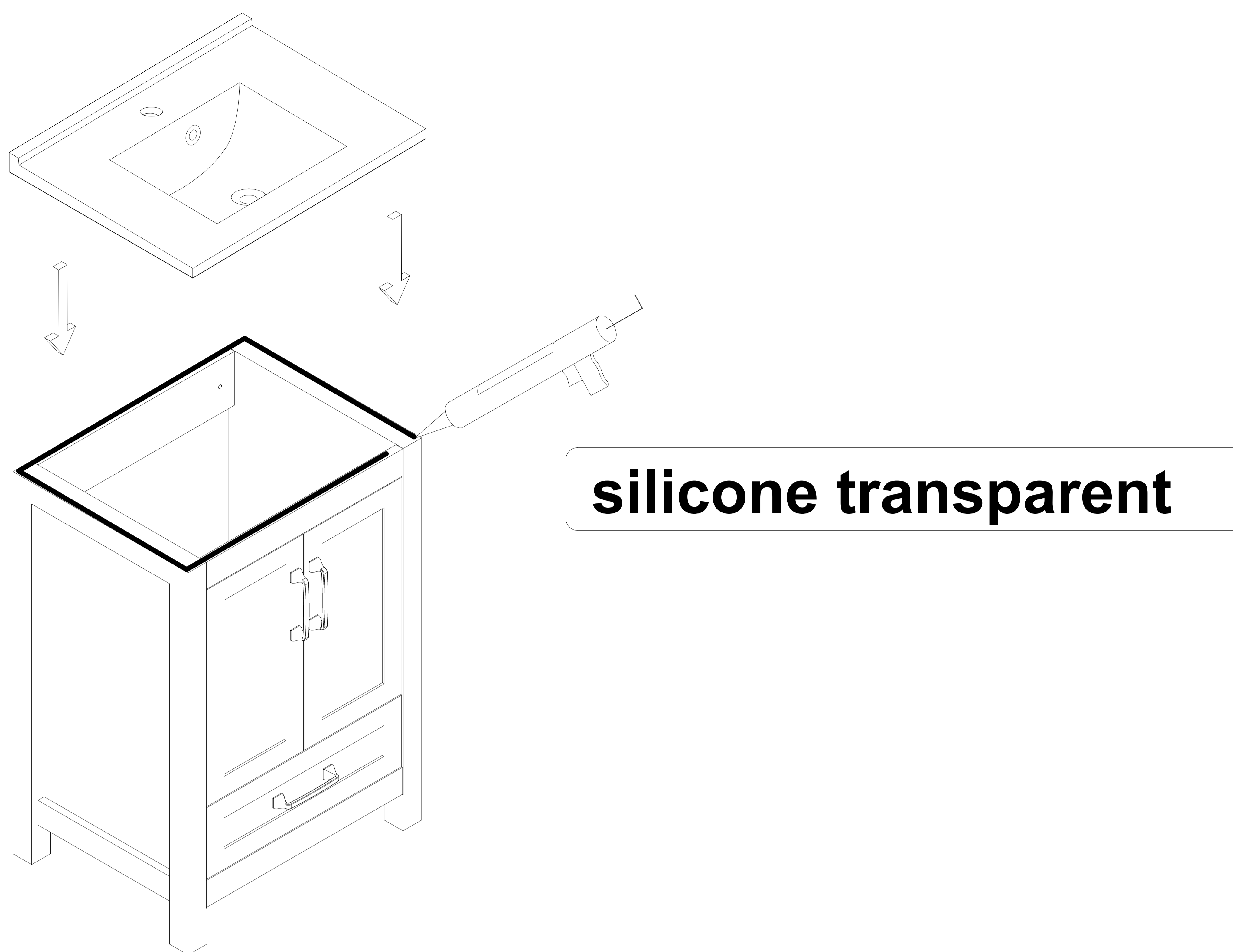

STEP 15

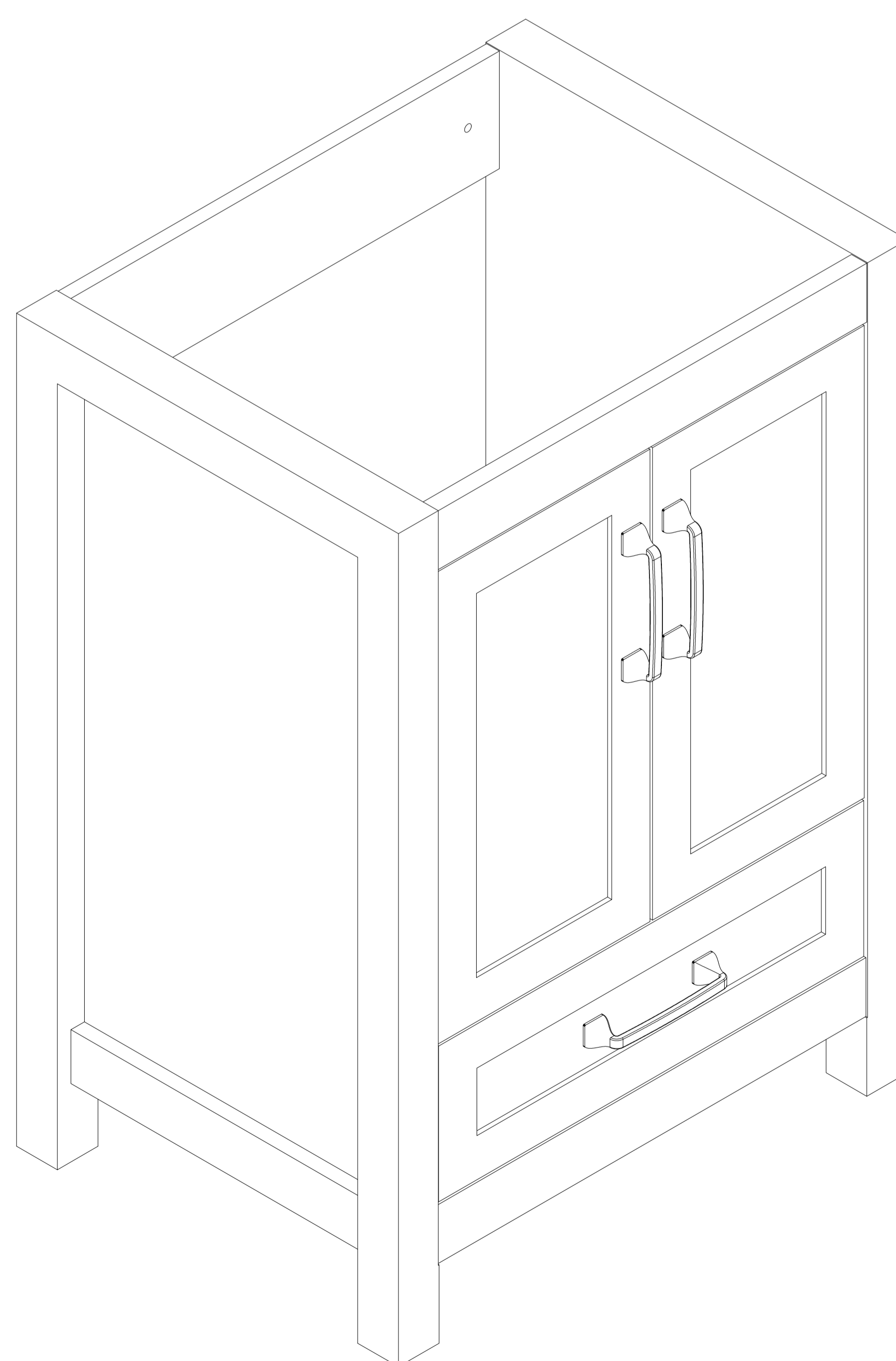

To help prevent mildew, apply sealant to the space between the wall and the edge of the cabinet.

CARE AND CLEANING

1. Many cleansers contain abrasive and chemical substances which are not suitable for cleaning stainless steel, enamel, plating or plastic products. You may use mild cleansers or soaps to clean the surfaces. Wipe any splashes of cleaner solutions from the surface with a clean soft cloth.
2. Maintain ventilation in the bathroom and separate the dry area from the damp one if conditions permit. Try to open the door and windows of the bathroom to maintain adequate ventilation.
3. This cabinet is built to withstand normal bathroom humidity. For best results, keep this vanity dry and take necessary steps to minimize bathroom humidity by opening windows and doors and using the exhaust fan (if available).
4. To maintain the cabinet door, clean and wipe the door regularly with a soft cloth. Wipe condensation with a dry soft cloth. Keep away from heat and high temperatures.
5. Please do not sit, lean or step on the basin cabinet.

Thank you very much for purchasing from e-clife

We have always been trying to provide the best service and reliable products for every customer.

However, accidents may happen sometimes, please contact

us to resolve any issue before leaving a negative feedback.

Many thanks and welcome to our shop again!