

4 DRAWER DRESSER

Weight Limit
50.7 lbs / 23 kg



THIS INSTRUCTION BOOKLET CONTAINS **IMPORTANT** SAFETY INFORMATION. PLEASE READ AND KEEP FOR FUTURE REFERENCE.

Limited 1 year Warranty

We warrants this product to be free from defects in material and workmanship and agrees to remedy any such defect. This warranty covers one year from the date of original purchase from authorized retailers. This is solely limited to the repair or replacement of defective parts and assembly labor is not included.

This warranty does not apply to any product which has been improperly assembled, subjected to misuse or abuse or which has been altered or repaired in any way. The warranty does not cover wearing, tearing, fading or splitting of the fabric (where applicable). Liability for consequential damages is excluded to the extent exclusion is permitted by law. This warranty gives you specific legal rights and you may also have other rights which vary from state to state or province to province.

To obtain warranty service, purchaser must present original bill of sale. Components repaired or replaced are warranted through the remainder of the original warranty period only. The defective components will be repaired or replaced without charge, subject to the terms and conditions described above.

The terms and conditions of the limited warranty are subject to change without notice.

Read Before Beginning Assembly

- Work in a spacious area and near where the unit will be used, preferably on a carpet, or use a piece of the cardboard packaging to protect your floor and product.
- Make sure all parts are included. Most parts are labeled or stamped on the raw edge.
- Read each step carefully. It is very important that each step of the instructions is performed in the correct order. If these steps are not followed in sequence, assembly difficulties will occur.
- This product may contain small components. Please ensure that they are kept away from small children.
- This product is designed for home use and is not intended for commercial use.

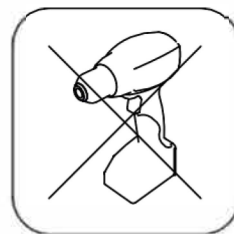
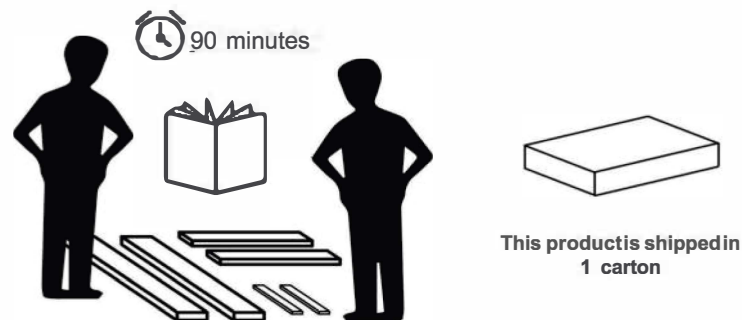

Do NOT use
power tools

Tools required to complete assembly (not included)

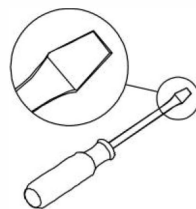

Flat head screwdriver



Phillips head screwdriver







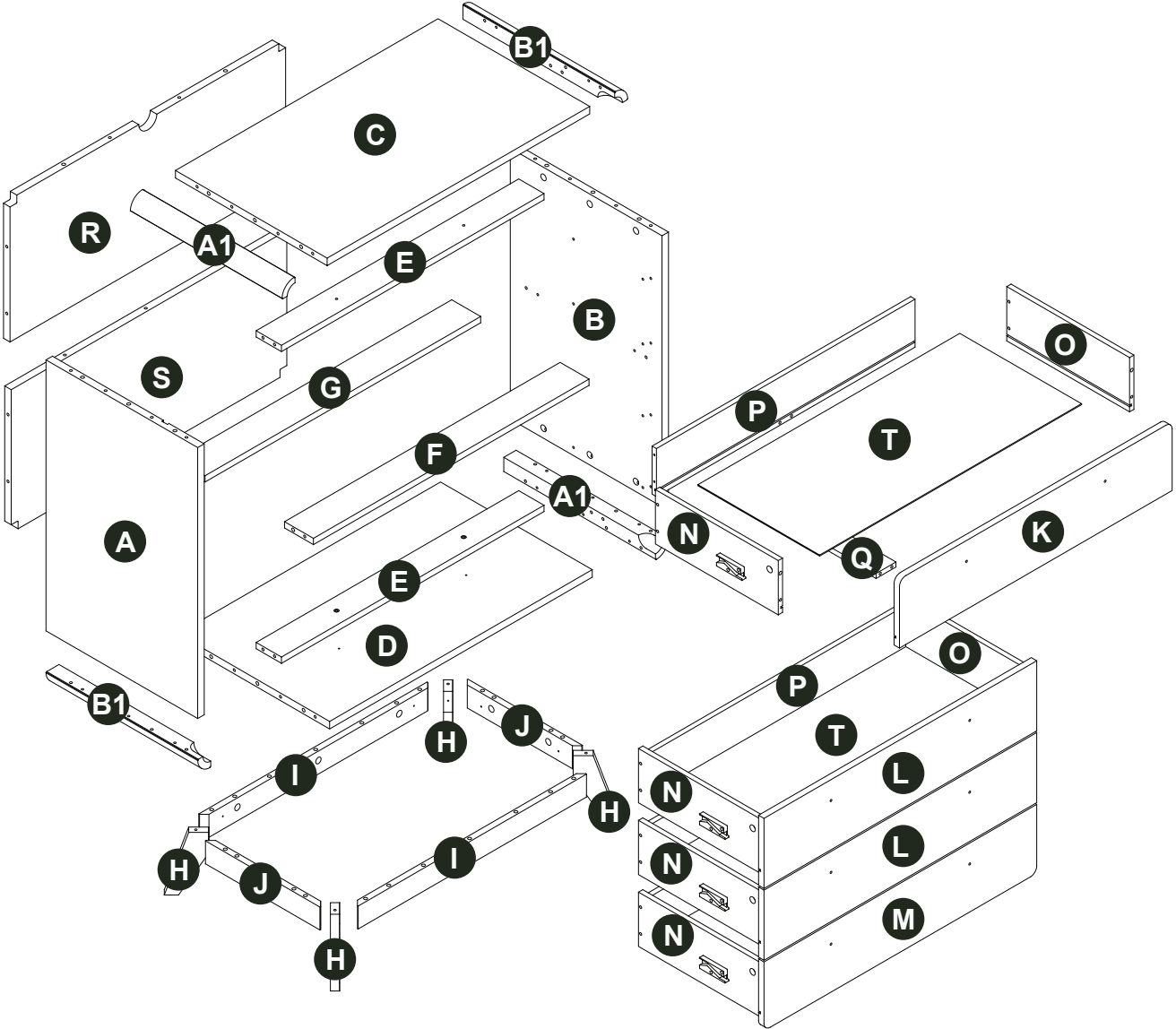

Mallet

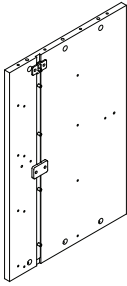
PARTS

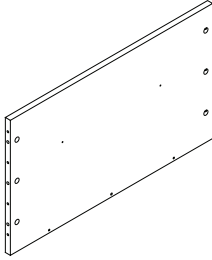
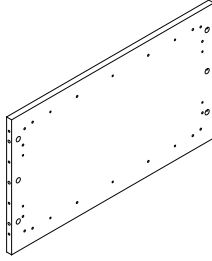
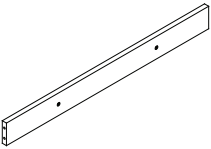
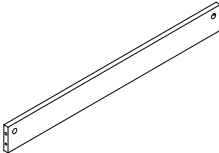
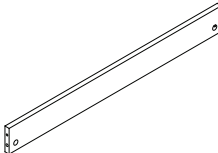

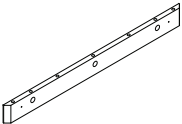

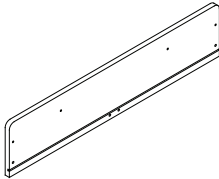
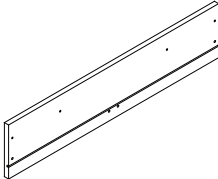
PARTS LIST

<p>A</p> 	<p>B</p> 	<p>C</p> 	<p>D</p> 
<p>SIDE PANEL LEFT 1 PC</p>	<p>SIDE PANEL RIGHT 1 PC</p>	<p>TOP PANEL 1 PC</p>	<p>BOTTOM PANEL 1 PC</p>
<p>E</p> 	<p>F</p> 	<p>G</p> 	<p>H</p> 
<p>TOP/BOTTOM SUPPORT PANEL 2 PC</p>	<p>SUPPORT FRONT PANEL 1 PC</p>	<p>BACK SUPPORT PANEL 1 PC</p>	<p>LEG PANEL 4 PC</p>
<p>I</p> 	<p>J</p> 	<p>K</p> 	<p>L</p> 
<p>LEG FRAME PANEL 2 PC</p>	<p>LEG FRAME SIDE PANEL 2 PC</p>	<p>DRAWER FRONT TOP 1 PC</p>	<p>DRAWER FRONT CENTER 2 PC</p>

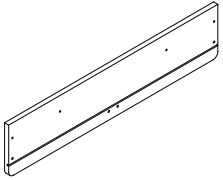
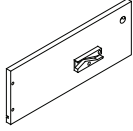
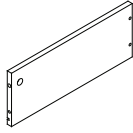
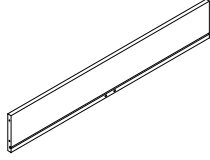
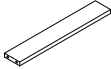
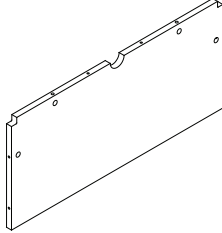
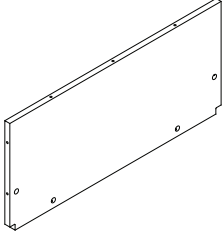
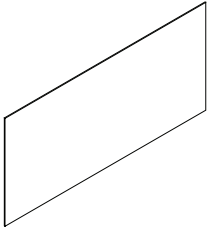
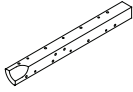
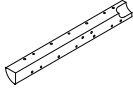

PARTS LIST

																																																																																																	
<p>DRAWER FRONT BOTTOM 1 PC</p>	<p>DRAWER SIDE RIGHT 4 PC</p>	<p>DRAWER SIDE LEFT 4 PC</p>	<p>DRAWER BACK 4 PC</p>																																																																																														
																																																																																																	
<p>DRAWER SUPPORT 4 PC</p>	<p>BACK PANEL TOP 1 PC</p>	<p>BACK PANEL BOTTOM 1 PC</p>	<p>DRAWER BOTTOM 4 PC</p>																																																																																														
PART NUMBERS																																																																																																	
<table border="1"> <thead> <tr> <th>PART LABELS</th> <th>(Oak/Black)</th> <th>(Walnut/Walnut)</th> <th>(Paloma Grey)</th> </tr> </thead> <tbody> <tr><td>A</td><td>U5675611-A</td><td>U5675877-A</td><td>U5675622-A</td></tr> <tr><td>B</td><td>U5675611-B</td><td>U5675877-B</td><td>U5675622-B</td></tr> <tr><td>C</td><td>U5675611-C</td><td>U5675877-C</td><td>U5675622-C</td></tr> <tr><td>D</td><td>U5675611-D</td><td>U5675877-D</td><td>U5675622-D</td></tr> <tr><td>E</td><td>U5675611-E</td><td>U5675877-E</td><td>U5675622-E</td></tr> <tr><td>F</td><td>U5675611-F</td><td>U5675877-F</td><td>U5675622-F</td></tr> <tr><td>G</td><td>U5675611-G</td><td>U5675877-G</td><td>U5675622-G</td></tr> <tr><td>H</td><td>U5675611-H</td><td>U5675877-H</td><td>U5675622-H</td></tr> <tr><td>I</td><td>U5675611-I</td><td>U5675877-I</td><td>U5675622-I</td></tr> <tr><td>J</td><td>U5675611-J</td><td>U5675877-J</td><td>U5675622-J</td></tr> <tr><td>K</td><td>U5675611-K</td><td>U5675877-K</td><td>U5675622-K</td></tr> <tr><td>L</td><td>U5675611-L</td><td>U5675877-L</td><td>U5675622-L</td></tr> <tr><td>M</td><td>U5675611-M</td><td>U5675877-M</td><td>U5675622-M</td></tr> <tr><td>N</td><td>U5675611-N</td><td>U5675877-N</td><td>U5675622-N</td></tr> <tr><td>O</td><td>U5675611-O</td><td>U5675877-O</td><td>U5675622-O</td></tr> <tr><td>P</td><td>U5675611-P</td><td>U5675877-P</td><td>U5675622-P</td></tr> </tbody> </table>	PART LABELS	(Oak/Black)	(Walnut/Walnut)	(Paloma Grey)	A	U5675611-A	U5675877-A	U5675622-A	B	U5675611-B	U5675877-B	U5675622-B	C	U5675611-C	U5675877-C	U5675622-C	D	U5675611-D	U5675877-D	U5675622-D	E	U5675611-E	U5675877-E	U5675622-E	F	U5675611-F	U5675877-F	U5675622-F	G	U5675611-G	U5675877-G	U5675622-G	H	U5675611-H	U5675877-H	U5675622-H	I	U5675611-I	U5675877-I	U5675622-I	J	U5675611-J	U5675877-J	U5675622-J	K	U5675611-K	U5675877-K	U5675622-K	L	U5675611-L	U5675877-L	U5675622-L	M	U5675611-M	U5675877-M	U5675622-M	N	U5675611-N	U5675877-N	U5675622-N	O	U5675611-O	U5675877-O	U5675622-O	P	U5675611-P	U5675877-P	U5675622-P	<table border="1"> <thead> <tr> <th>PART LABELS</th> <th>(Oak/Black)</th> <th>(Walnut/Walnut)</th> <th>(Paloma Grey)</th> </tr> </thead> <tbody> <tr><td>Q</td><td>U5675611-Q</td><td>U5675877-Q</td><td>U5675622-Q</td></tr> <tr><td>R</td><td>U5675611-R</td><td>U5675877-R</td><td>U5675622-R</td></tr> <tr><td>S</td><td>U5675611-S</td><td>U5675877-S</td><td>U5675622-S</td></tr> <tr><td>T</td><td>U5675611-T</td><td>U5675877-T</td><td>U5675622-T</td></tr> <tr><td>A1</td><td>U5675611-A1</td><td>U5675877-A1</td><td>U5675622-A1</td></tr> <tr><td>B1</td><td>U5675611-B1</td><td>U5675877-B1</td><td>U5675622-B1</td></tr> </tbody> </table>	PART LABELS	(Oak/Black)	(Walnut/Walnut)	(Paloma Grey)	Q	U5675611-Q	U5675877-Q	U5675622-Q	R	U5675611-R	U5675877-R	U5675622-R	S	U5675611-S	U5675877-S	U5675622-S	T	U5675611-T	U5675877-T	U5675622-T	A1	U5675611-A1	U5675877-A1	U5675622-A1	B1	U5675611-B1	U5675877-B1	U5675622-B1
PART LABELS	(Oak/Black)	(Walnut/Walnut)	(Paloma Grey)																																																																																														
A	U5675611-A	U5675877-A	U5675622-A																																																																																														
B	U5675611-B	U5675877-B	U5675622-B																																																																																														
C	U5675611-C	U5675877-C	U5675622-C																																																																																														
D	U5675611-D	U5675877-D	U5675622-D																																																																																														
E	U5675611-E	U5675877-E	U5675622-E																																																																																														
F	U5675611-F	U5675877-F	U5675622-F																																																																																														
G	U5675611-G	U5675877-G	U5675622-G																																																																																														
H	U5675611-H	U5675877-H	U5675622-H																																																																																														
I	U5675611-I	U5675877-I	U5675622-I																																																																																														
J	U5675611-J	U5675877-J	U5675622-J																																																																																														
K	U5675611-K	U5675877-K	U5675622-K																																																																																														
L	U5675611-L	U5675877-L	U5675622-L																																																																																														
M	U5675611-M	U5675877-M	U5675622-M																																																																																														
N	U5675611-N	U5675877-N	U5675622-N																																																																																														
O	U5675611-O	U5675877-O	U5675622-O																																																																																														
P	U5675611-P	U5675877-P	U5675622-P																																																																																														
PART LABELS	(Oak/Black)	(Walnut/Walnut)	(Paloma Grey)																																																																																														
Q	U5675611-Q	U5675877-Q	U5675622-Q																																																																																														
R	U5675611-R	U5675877-R	U5675622-R																																																																																														
S	U5675611-S	U5675877-S	U5675622-S																																																																																														
T	U5675611-T	U5675877-T	U5675622-T																																																																																														
A1	U5675611-A1	U5675877-A1	U5675622-A1																																																																																														
B1	U5675611-B1	U5675877-B1	U5675622-B1																																																																																														
																																																																																																	
		<p>SIDE PROFILE PANEL 2 PC</p>	<p>SIDE PROFILE PANEL 2 PC</p>																																																																																														





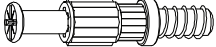
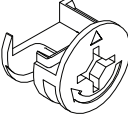
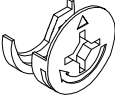
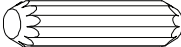
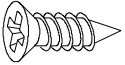
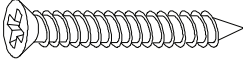
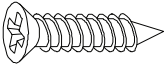
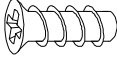
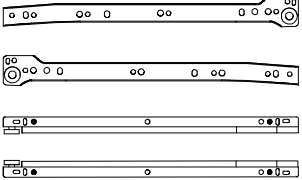
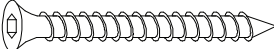

 Each part has a unique part number. Please reference the appropriate part number when contacting customer service for replacement parts.

 Before throwing any packaging, please verify all contents and make sure you have received all the parts listed above!

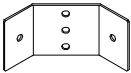

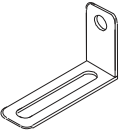
HARDWARE LIST

<p>①</p> 	<p>②</p> 	<p>③</p> 	<p>④</p> 
<p>20mm x 5mm MINIFIX 54 PC</p>	<p>12mm x 15mm CAM 46 PC</p>	<p>9mm x 15mm CAM 8 PC</p>	<p>6mm x 30mm WOOD DOWEL 91 PC</p>
<p>⑤</p> 	<p>⑥</p> 	<p>⑦</p> 	<p>⑧</p> 
<p>3.5mm x 15mm SCREW 32 PC</p>	<p>4.7mm x 38mm SCREW 16 PC</p>	<p>4mm x 25mm SCREW 8 PC</p>	<p>6mm x 13mm SCREW 16 PC</p>
<p>⑨</p> 	<p>⑩</p> 	<p>⑪</p> 	<p>⑫</p> 
<p>350 mm DRAWER SLIDE 4 SET</p>	<p>6mm x 40mm SCREW 4 PC</p>	<p>WOODEN KNOB HANDLE 4 PC</p>	<p>4mm x 25mm SCREW 4 PC</p>

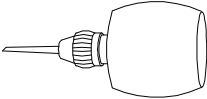
HARDWARE LIST

<p>⑬</p> 	<p>⑭</p> 	<p>⑮</p> 	<p>⑯</p> 
<p>TABLE CORNER BRACKET 5 HOLE 4 PC</p>	<p>ALLEN KEY M4 1 PC</p>	<p>L-MOUNTING BRACKET 1 PC</p>	<p>4mm x 16mm SCREW 1 PC</p>
<p>⑰</p> 	<p>⑱</p> 	<p>⑲</p> 	
<p>4mm x 52mm SCREW 1 PC</p>	<p>WALL PLUG 25MM 1 PC</p>	<p>GLUE 6 PC</p>	

Hardware Pack

(Oak/Black)		HP# : TU5675611-01
(Walnut/Walnut)		HP# : TU5675877-01
(Paloma Grey)		HP# : TU5675622-01

⚠ Please do not completely tighten all the hardware, until the entire assembly is complete, unless otherwise indicated in the step-by-step instructions.

⚠ The screw(s), bolt(s) to be used at each step are shown in actual size in the lower right corner of the page.

Step 1

Insert the dowel (4) on each panel as shown on the left.

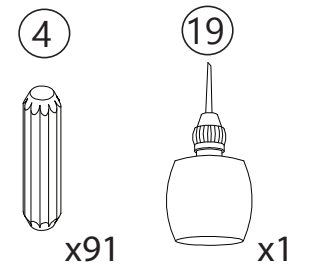
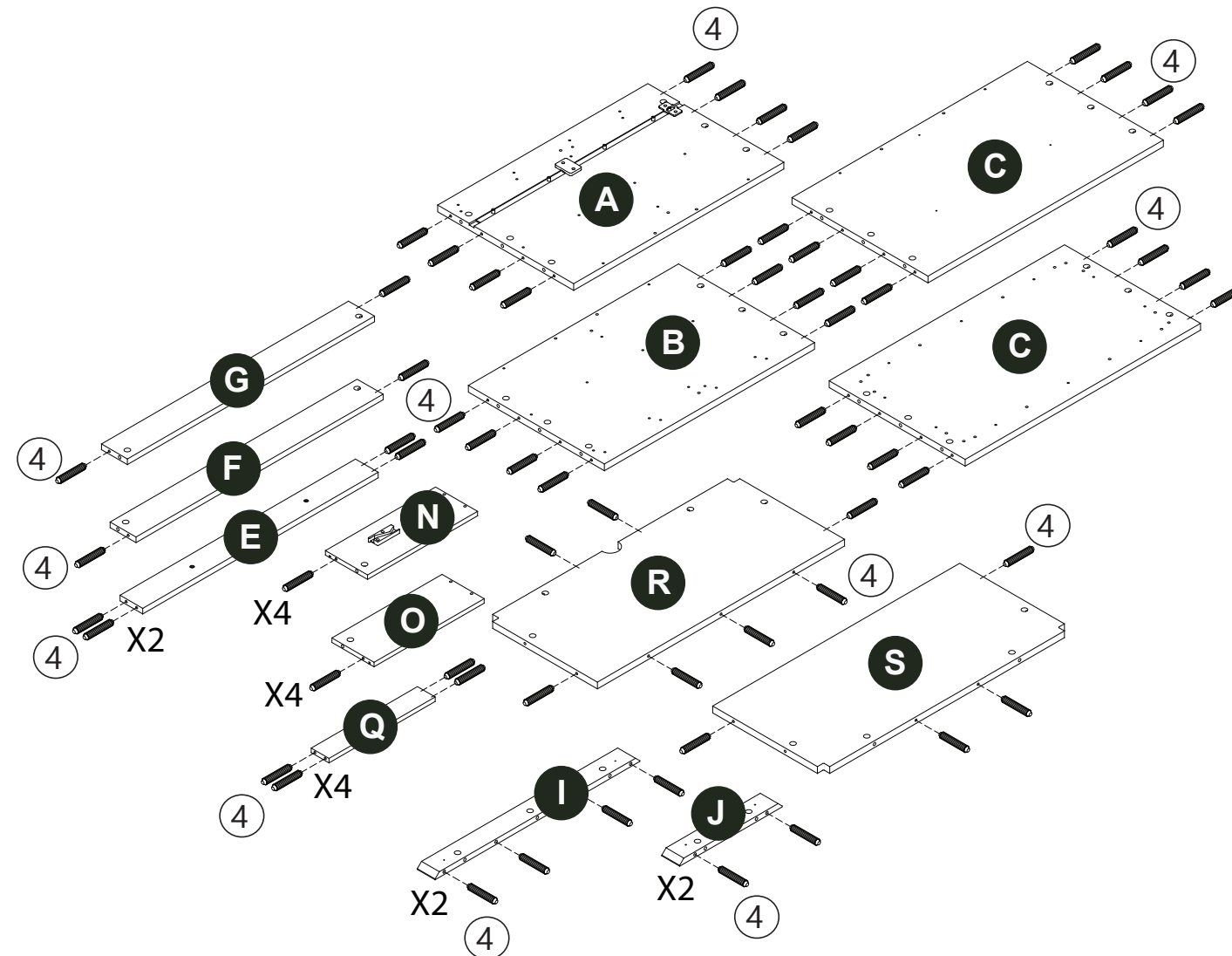
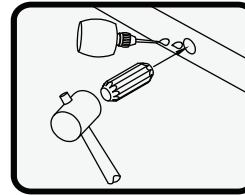

Step 2



Phillips head screwdriver

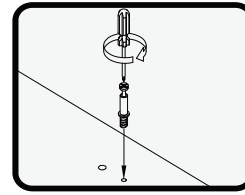
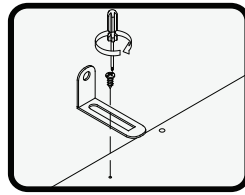

Insert the minifix (1) then tighten it with a screwdriver. Then align the L-mounting bracket (15) then tighten it with screw (16).

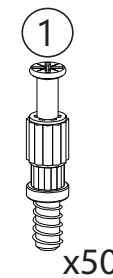
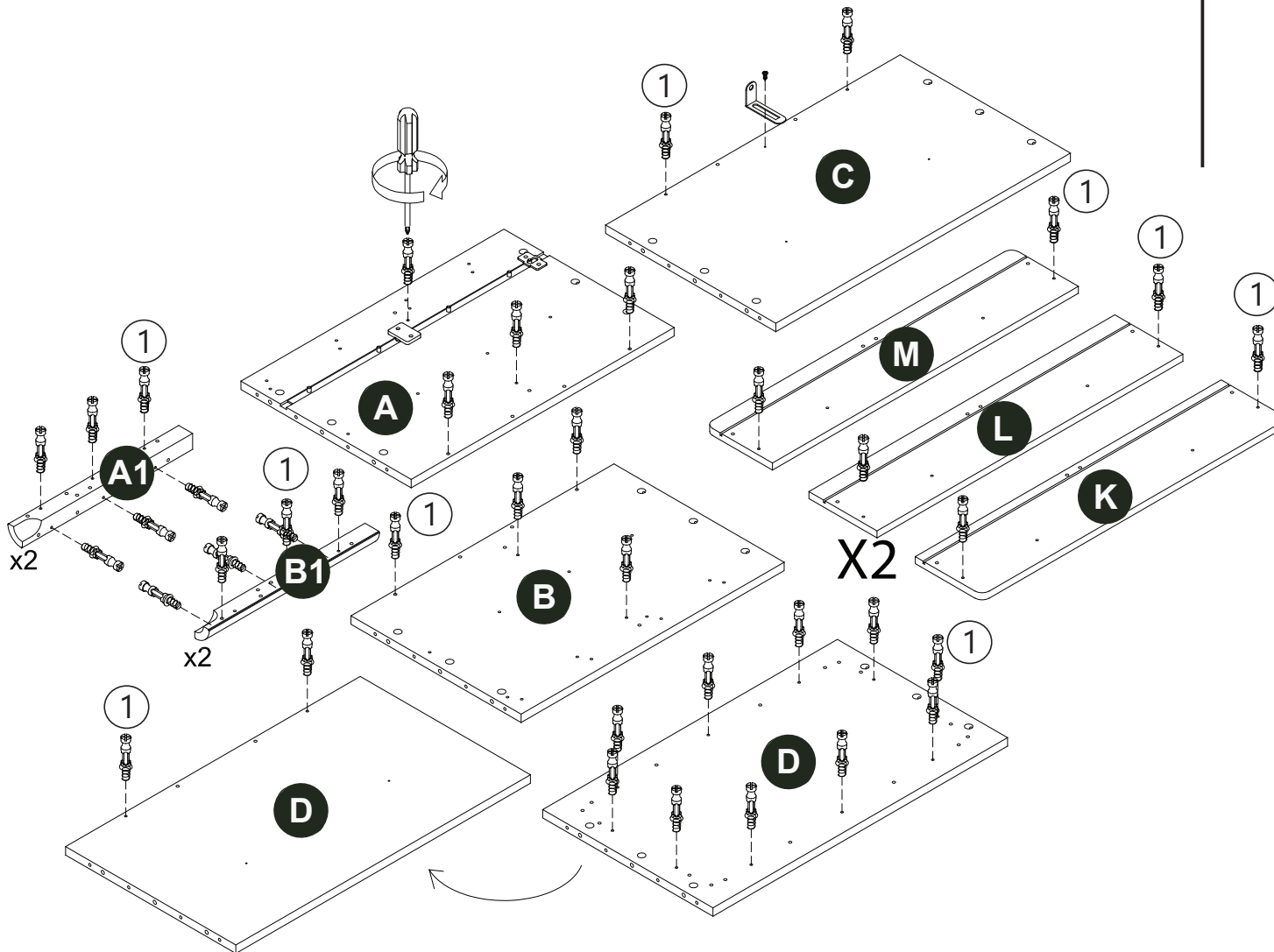

x50

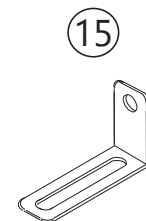

x1



x1

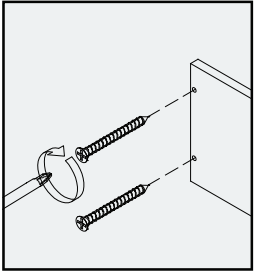

Step 3

Attached drawer side panels **N** & **O** to drawer back **P** and then tighten it with screw (6).

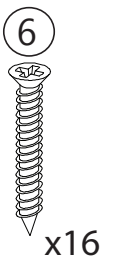
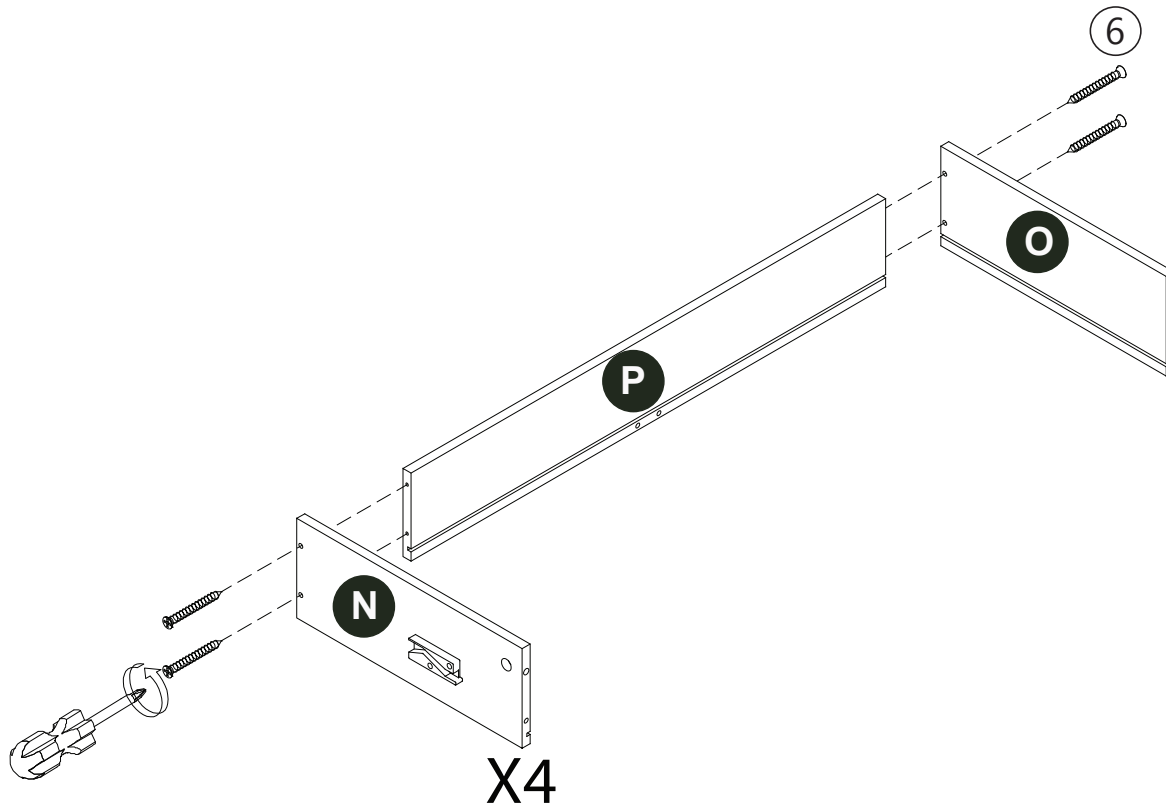

Step 4

Insert drawer bottom **T** between drawer side **N** & **O** then continue with drawer support **Q**.

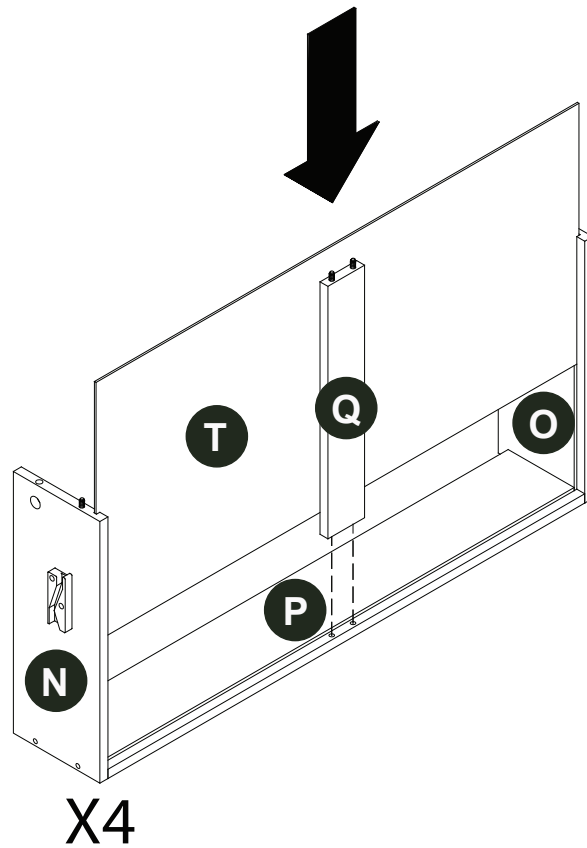

Step 5

Insert cam (3) in each panel and tighten all of it accordingly.

Before attach the other panel place a small drop of glue (19) in wood dowel hole.

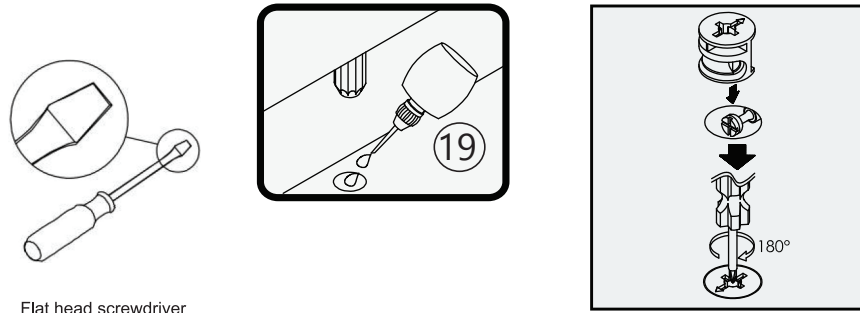

Flat head screwdriver

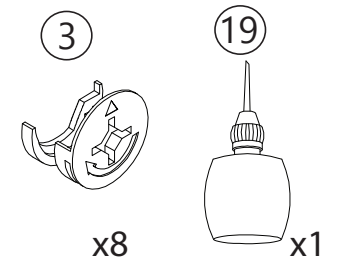
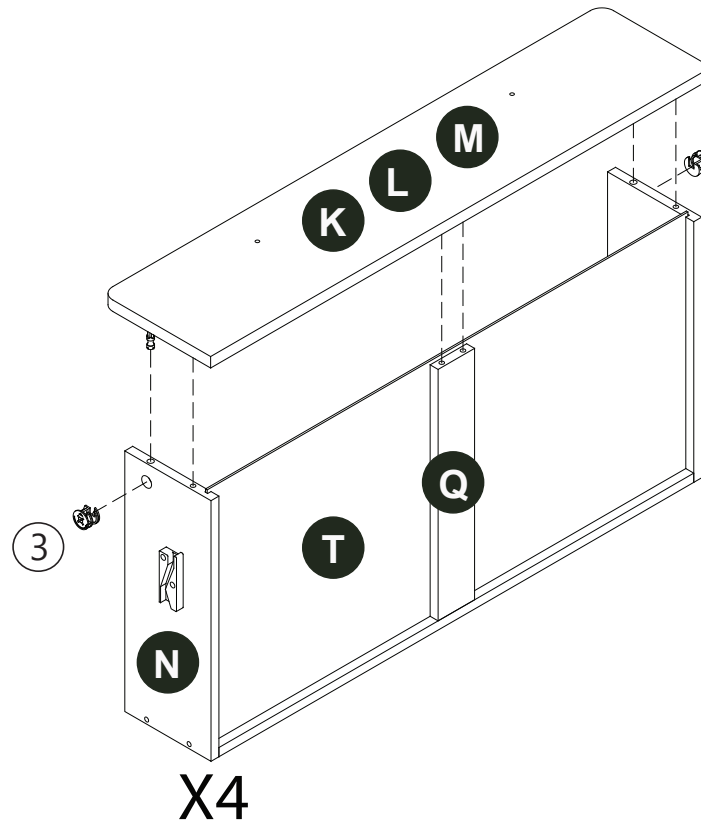

Step 6

Positioning the Drawer slide (9) make sure the drawer slide roller is facing on the drawer back as shown on the left then tighten it with screw (5).

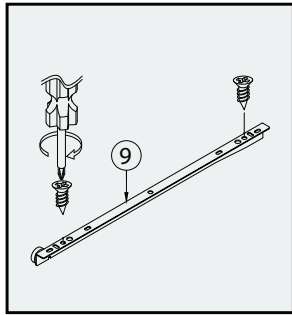

(L)

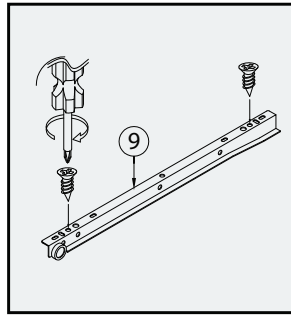

(R)

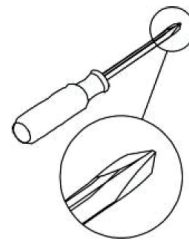

Phillips head screwdriver

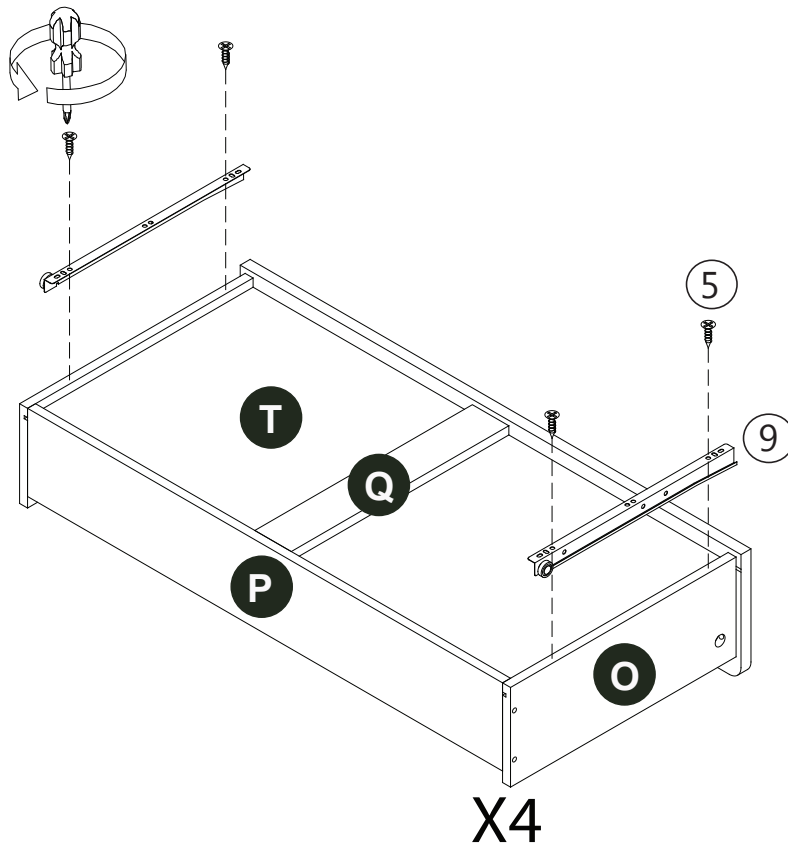

X4

5



x16

9

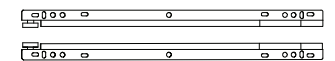

x4

Step 7

Use screw (12) and wooden knob handle (11) then tighten it using a screwdriver.

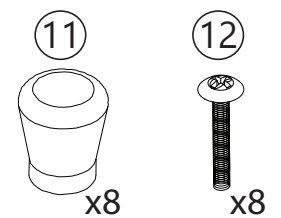
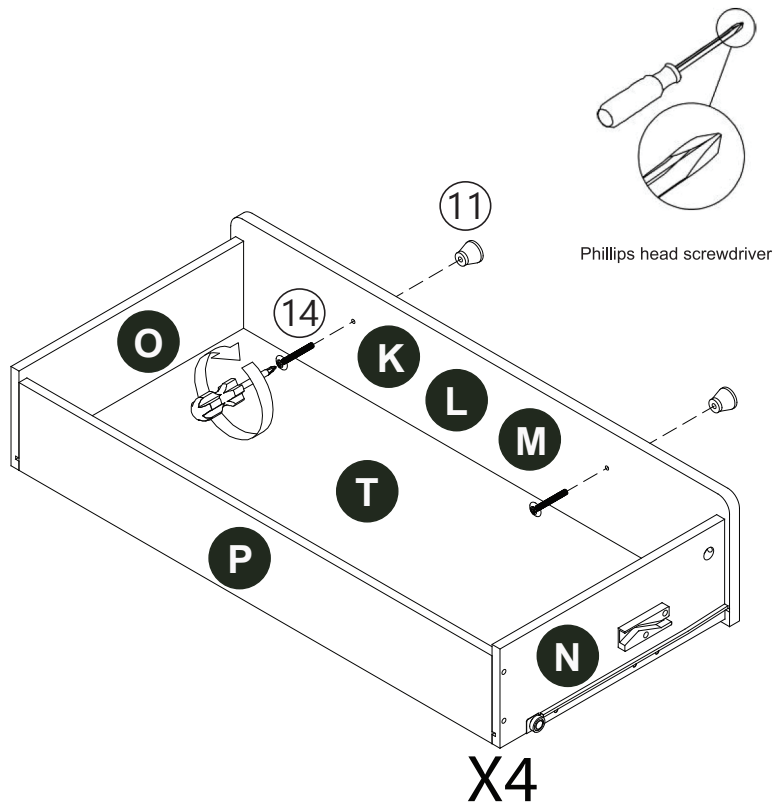

Step 8

Insert cam (2) in each panel and tighten all of it accordingly.
Before attach the other panel place a small drop of glue (19) in wood dowel hole.

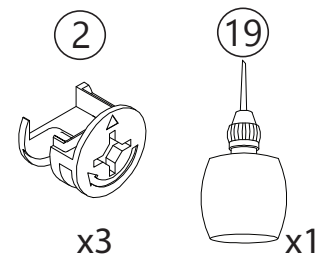
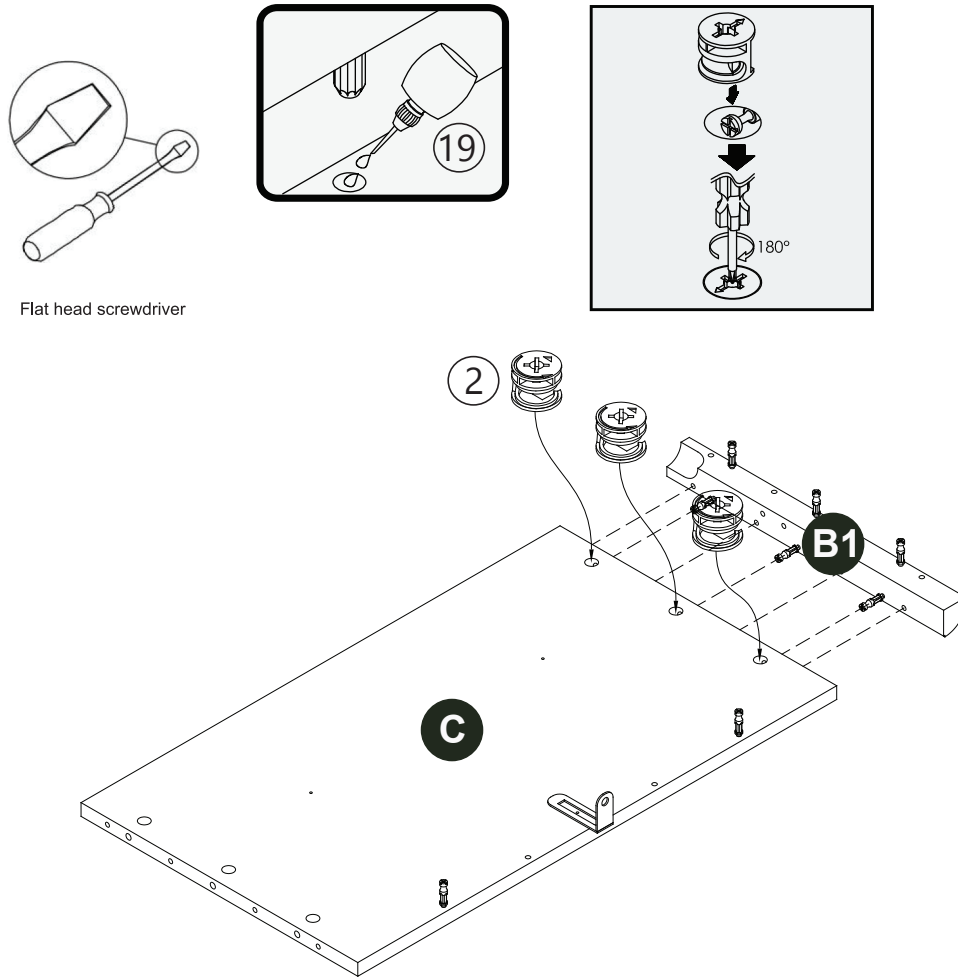

Step 9



Flat head screwdriver

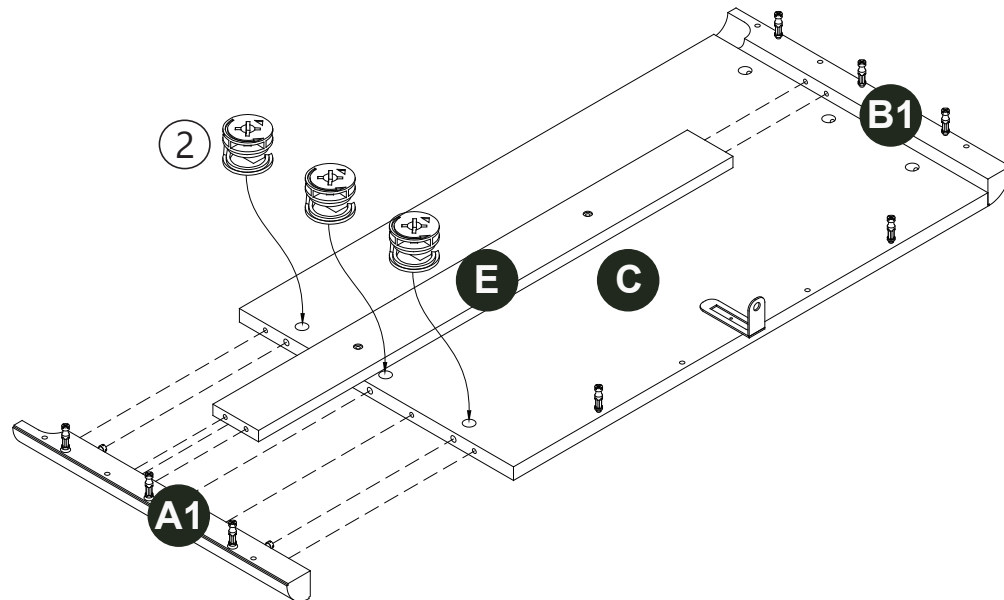
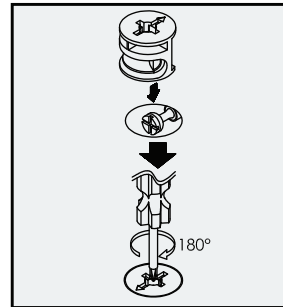
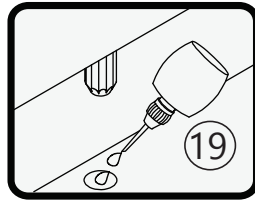

Insert cam (2) in each panel and tighten all of it accordingly.
Before attach the other panel place a small drop of glue (19) in wood dowel hole.

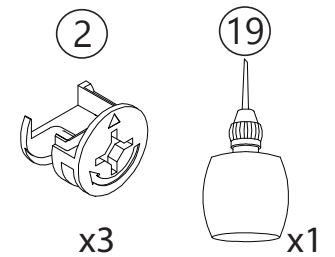



Flat head screwdriver

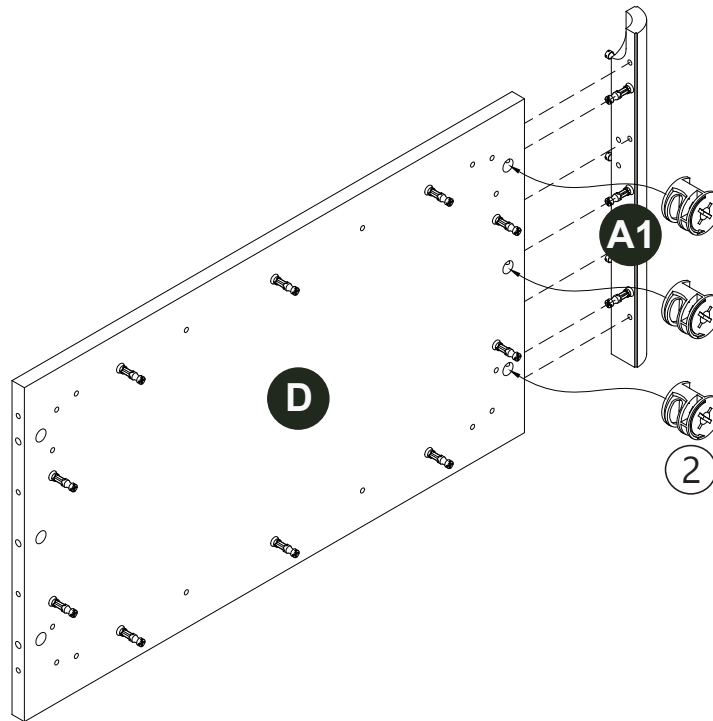
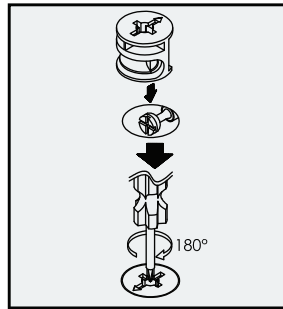
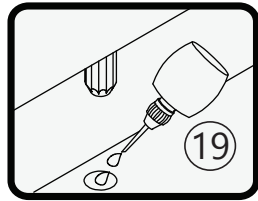

Step 10

Insert cam (2) in each panel and tighten all of it accordingly.

Before attach the other panel place a small drop of glue (19) in wood dowel hole.

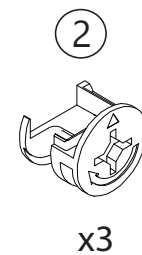

x3

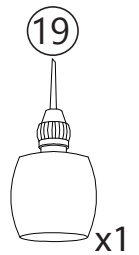

x1

Step 11

Insert cam (2) in each panel and tighten all of it accordingly.
Before attach the other panel place a small drop of glue (19) in wood dowel hole.

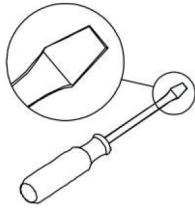

Flat head screwdriver

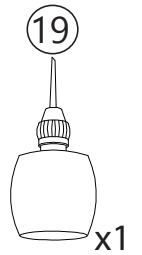
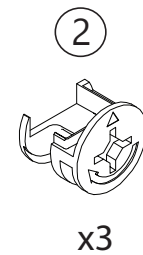
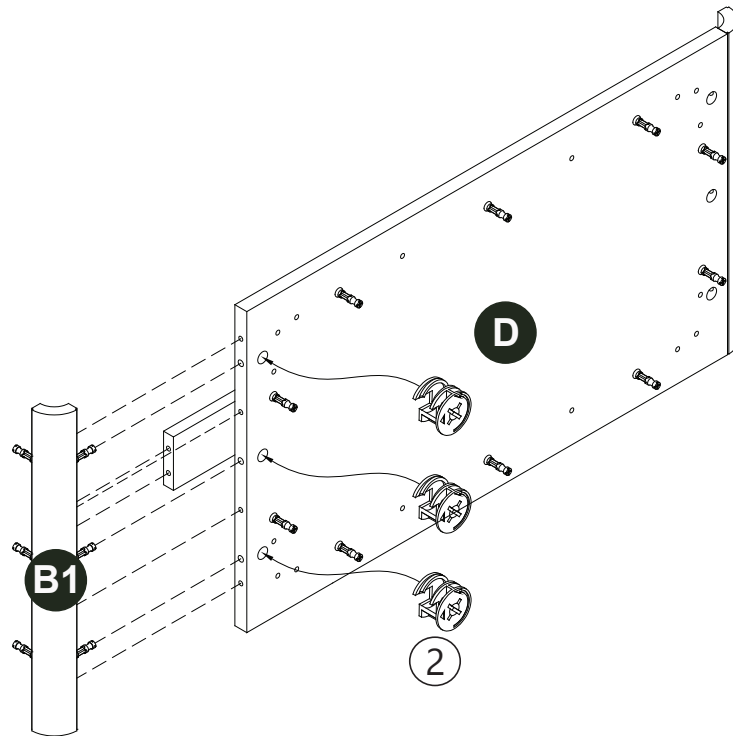
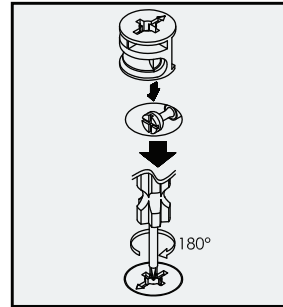
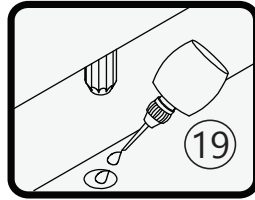

Step 12

Insert screw (7) on panel **E** and tighten all of it as shown.

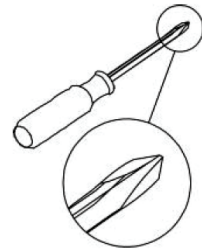

Phillips head screwdriver

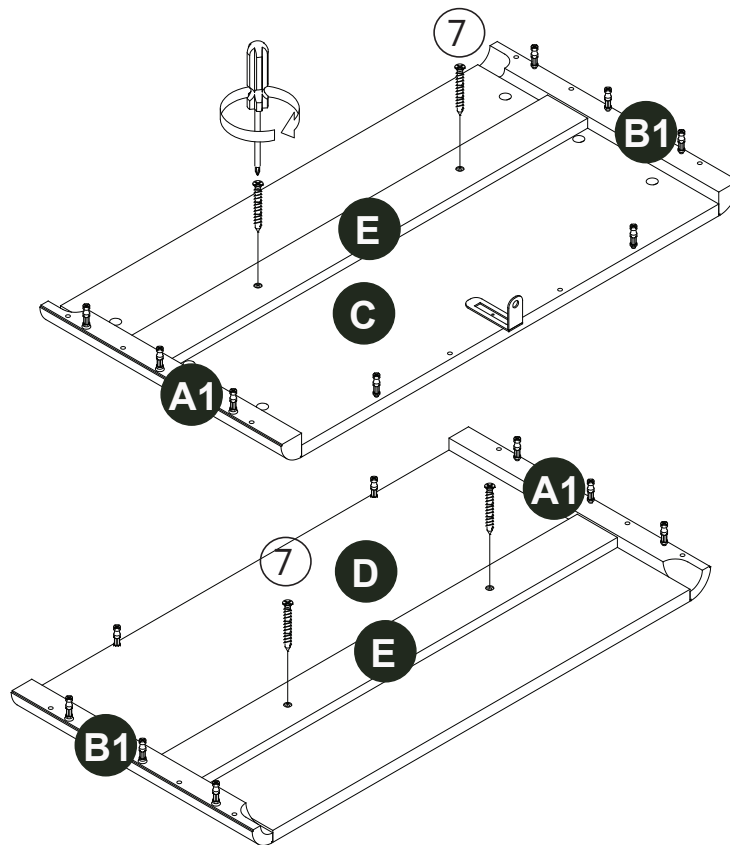

Step 13

Attached the leg frame panel **J** & **I** to bottom panel **D**.

Before attach the other panel place a small drop of glue (19) in wood dowel hole.

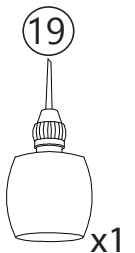
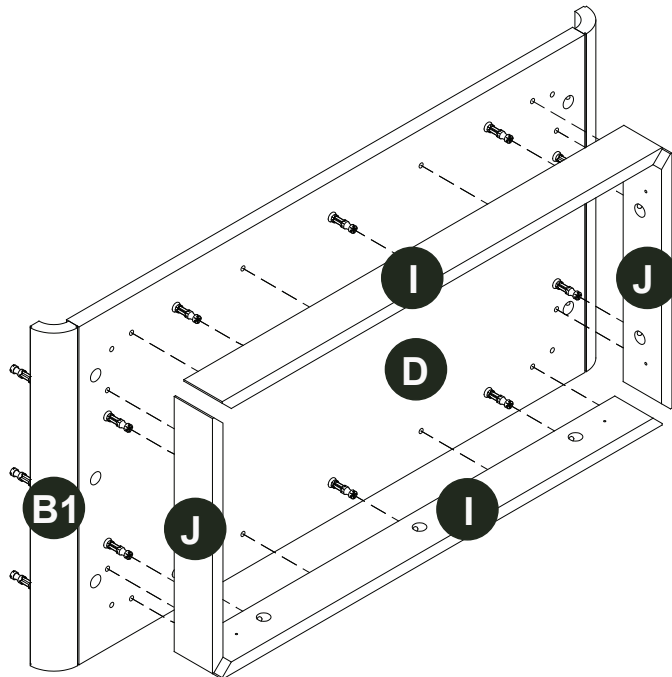
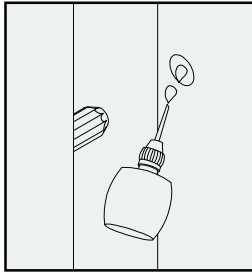

Step 14

Insert cam (2) in each panel and tighten all of it accordingly.

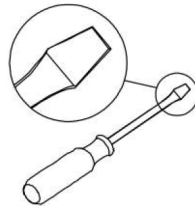

Flat head screwdriver

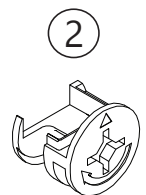
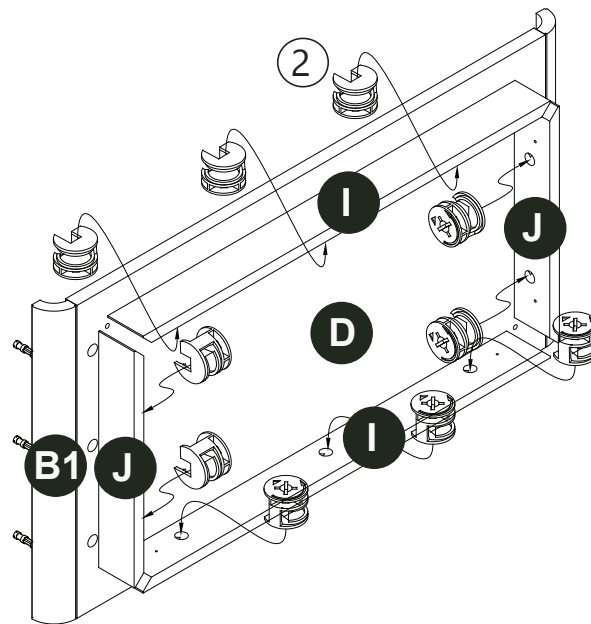
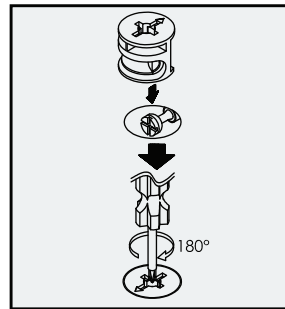

x10

Step 15

Attached the leg **H** to bottom panel **D** and tighten with screw (10).

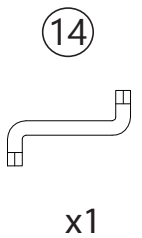
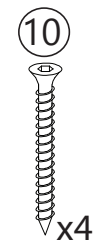
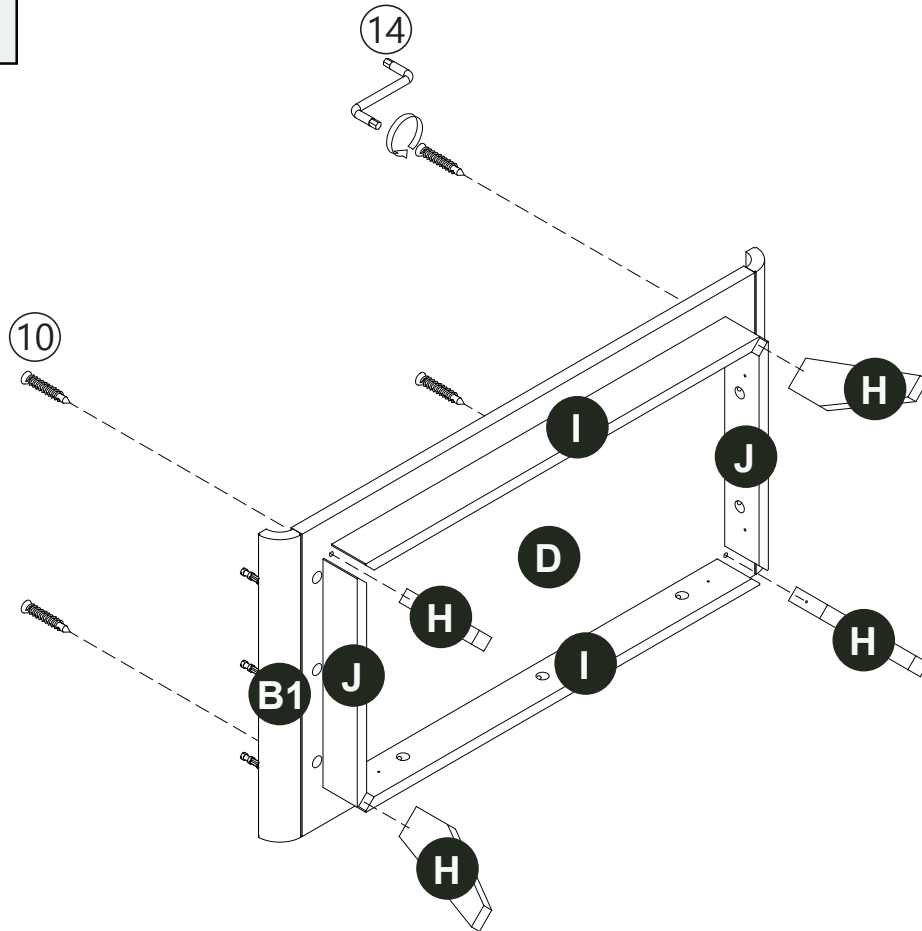
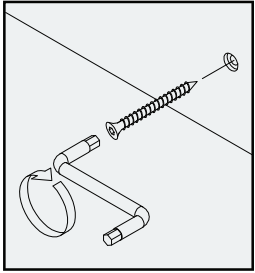

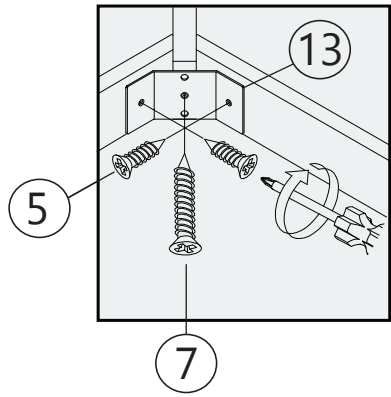

Phillips head screwdriver

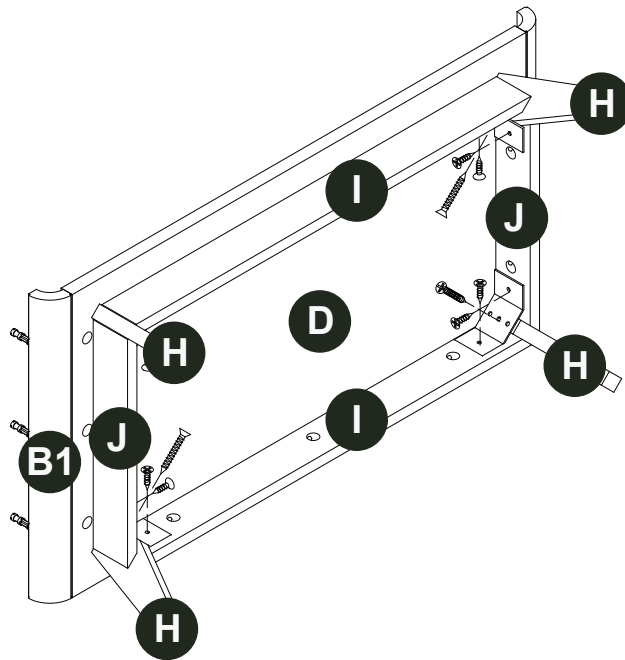

Step 16

Positioning the table corner bracket (13) at the leg frame and tighten the screw (5) & (7) and make sure position the screw according to the step display.

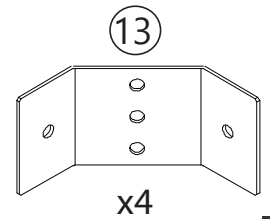
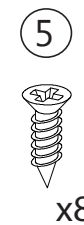

Step 17

Attached the back panel top **R** and back panel bottom **S**.

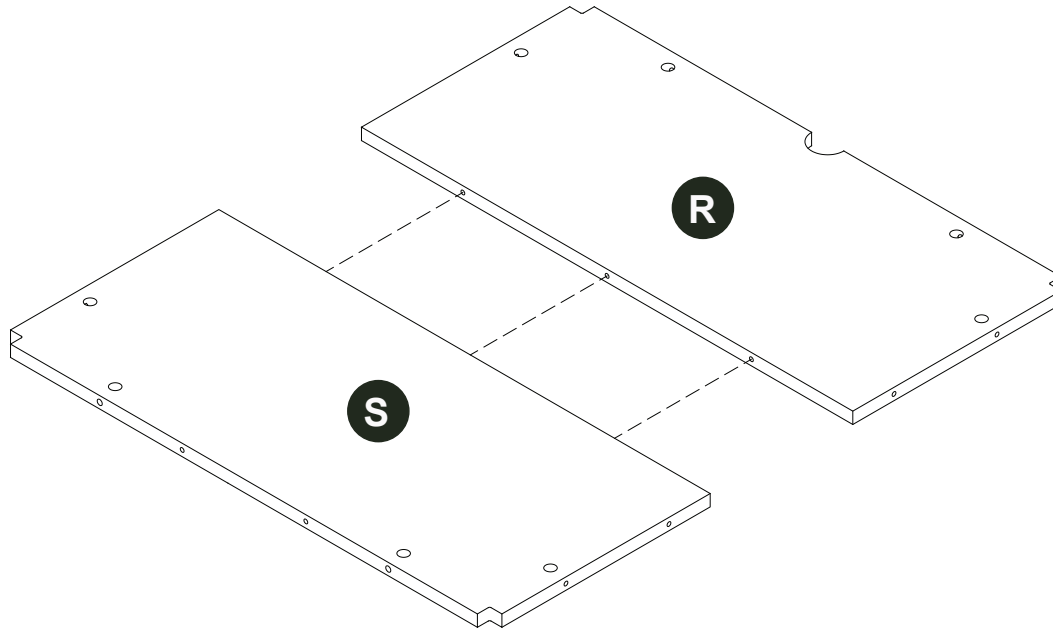

Step 18

Insert cam (2) in each panel and tighten all of it accordingly.
Before attach the other panel place a small drop of glue (19) in wood dowel hole.



Flat head screwdriver

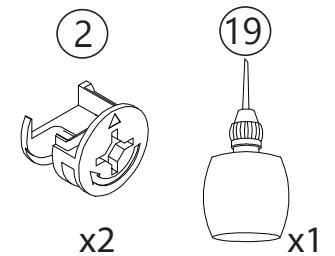
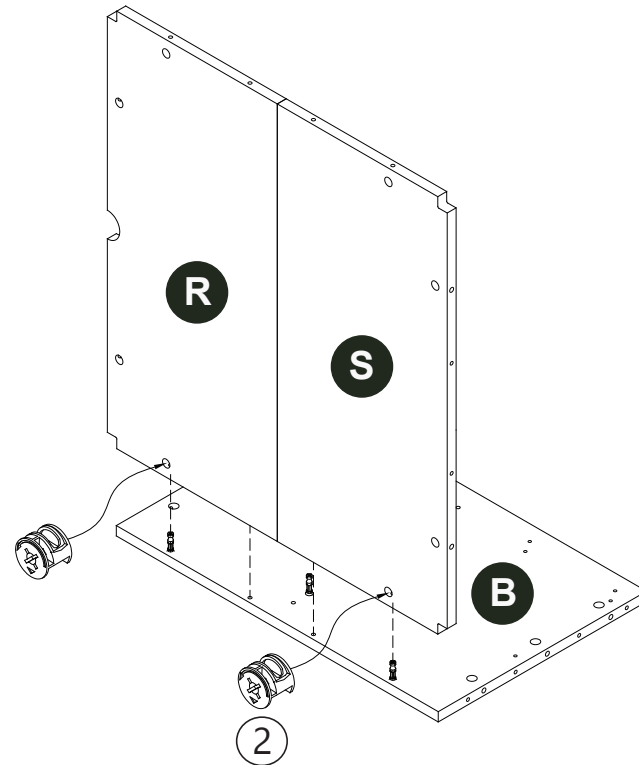
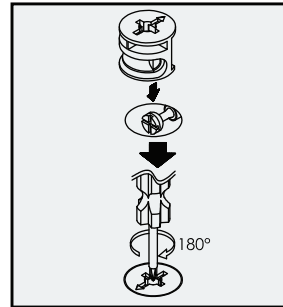
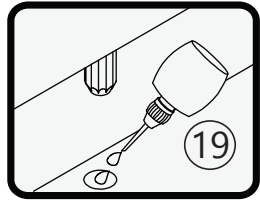

Step 19

Insert cam (2) in each panel and tighten all of it accordingly.
Before attach the other panel place a small drop of glue (19) in wood dowel hole.



Flat head screwdriver

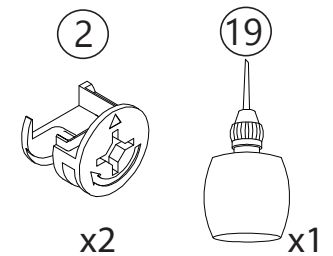
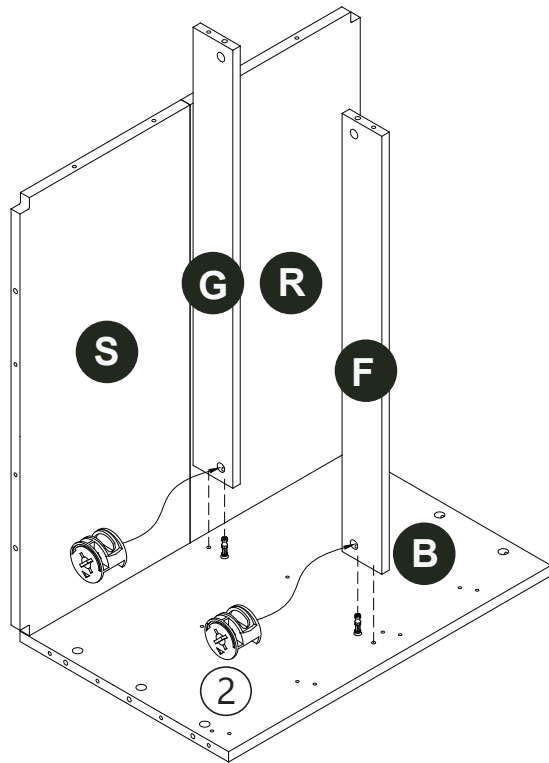
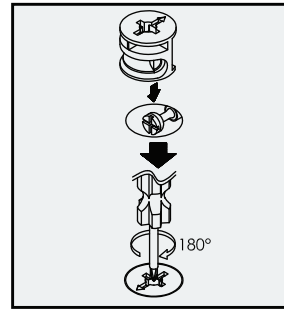
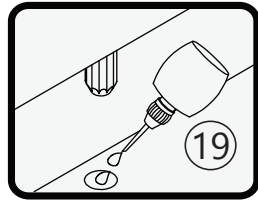

Step 20

Insert cam (2) in each panel and tighten all of it accordingly.
Before attach the other panel place a small drop of glue (19) in wood dowel hole.

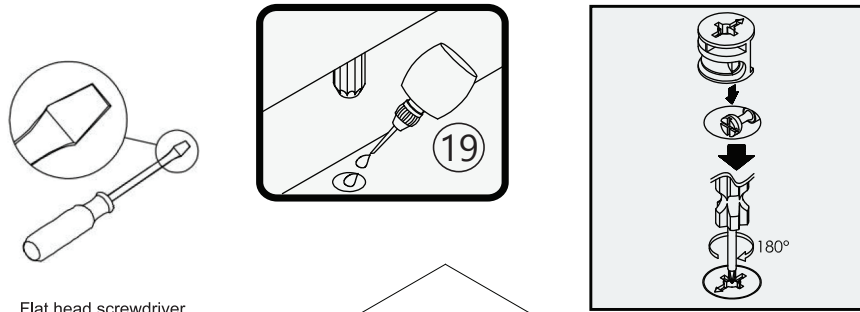

Flat head screwdriver

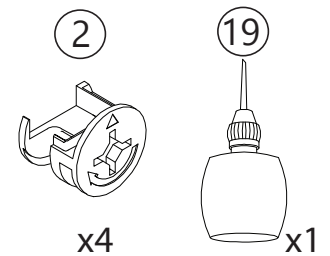
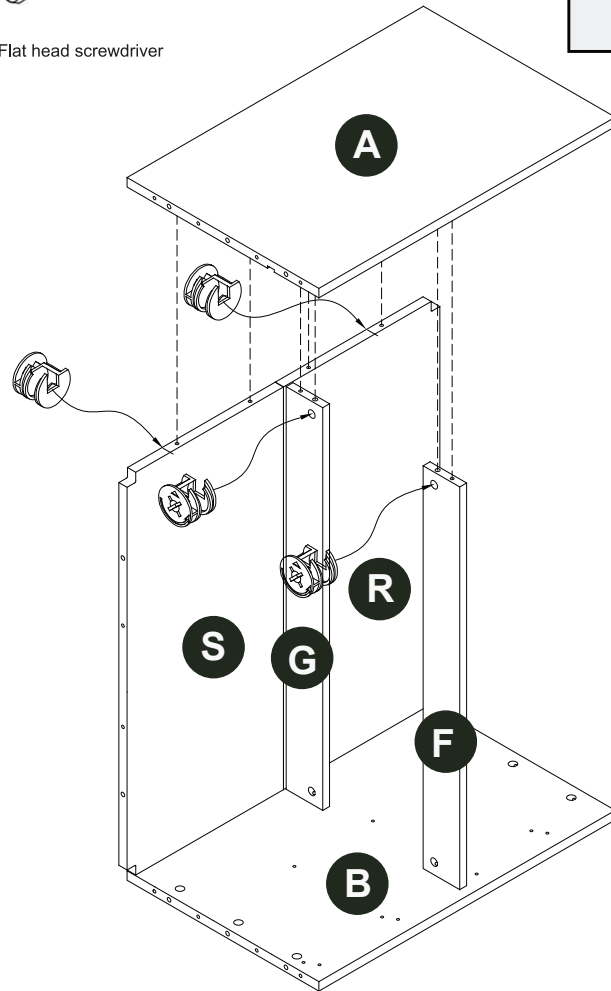

Step 21

Insert cam (2) in each panel and tighten all of it accordingly.
Before attach the other panel place a small drop of glue (19) in wood dowel hole.

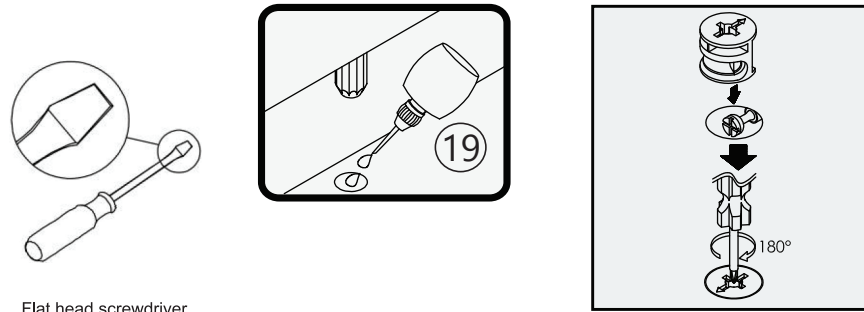

Flat head screwdriver

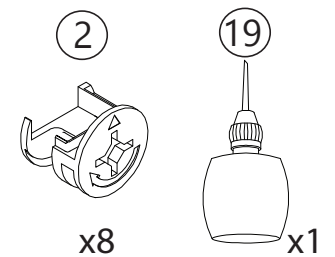
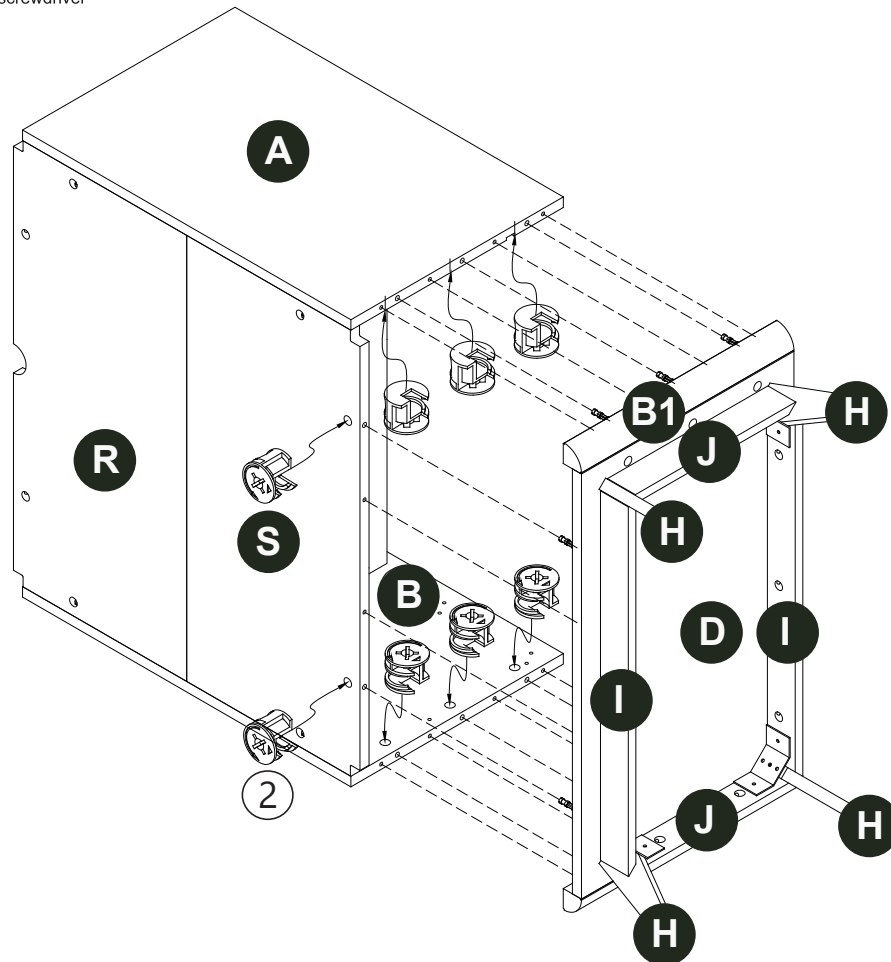

Step 22

Insert cam (2) in each panel and tighten all of it accordingly.
Before attach the other panel place a small drop of glue (19) in wood dowel hole.

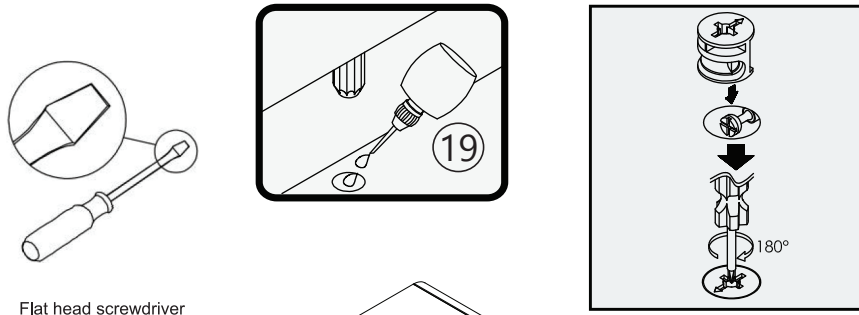

Flat head screwdriver

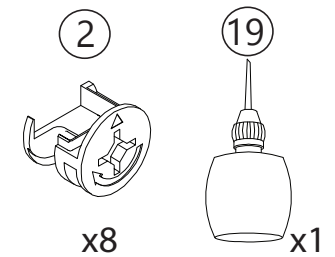
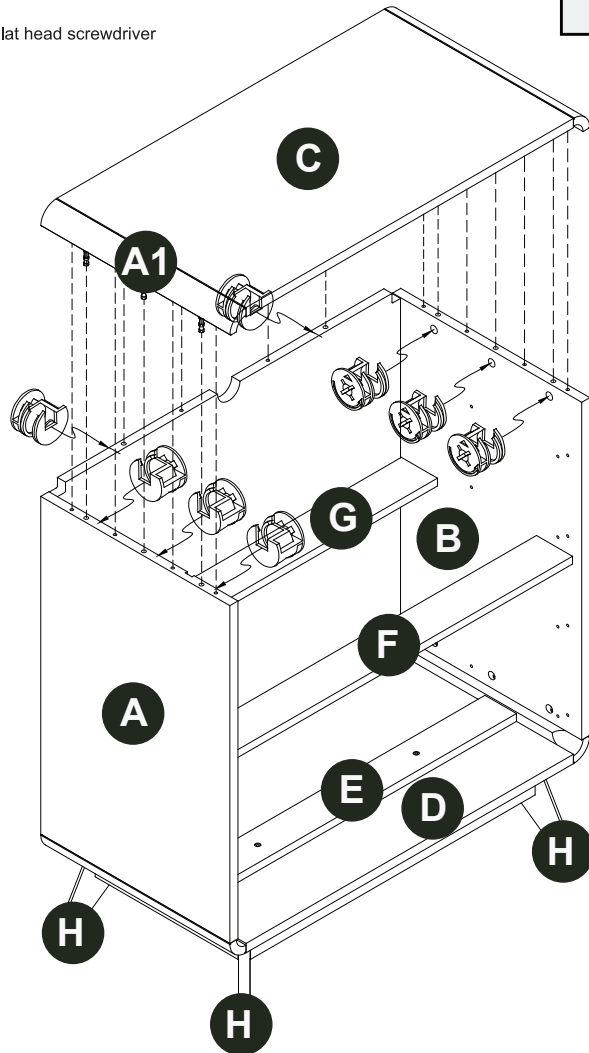

Step 23

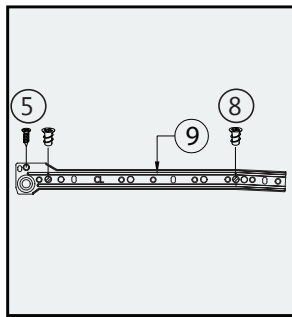

(L)

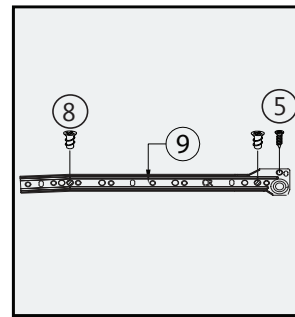

(R)



Phillips head screwdriver

Attached the drawer slide (9) and tighten it with screw (8) make sure to position the drawer slide as shown.

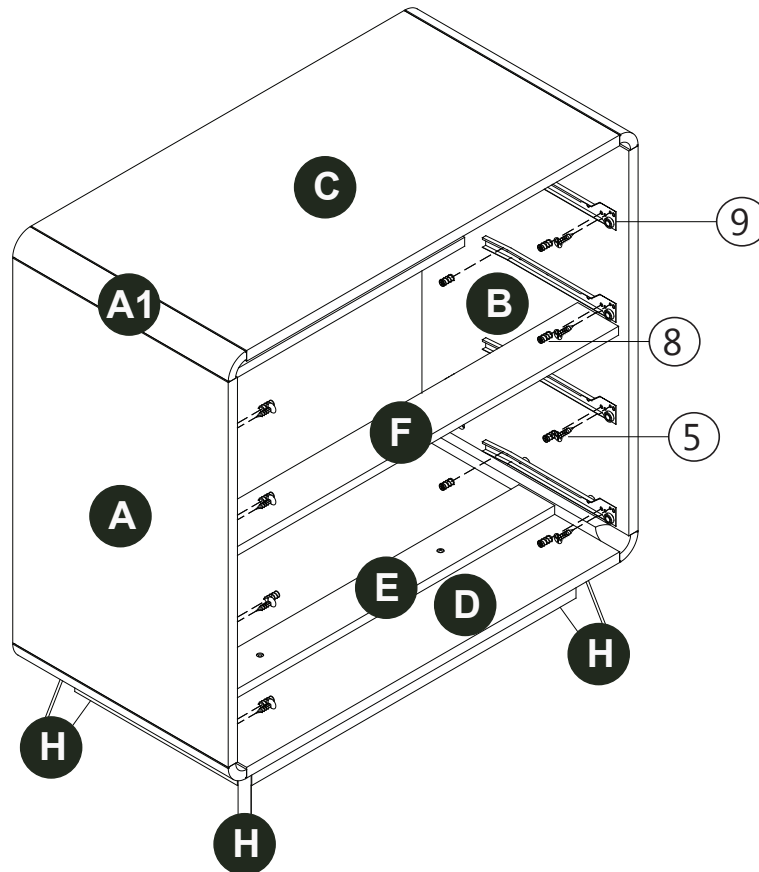

5



x8

8



x16

9



x4

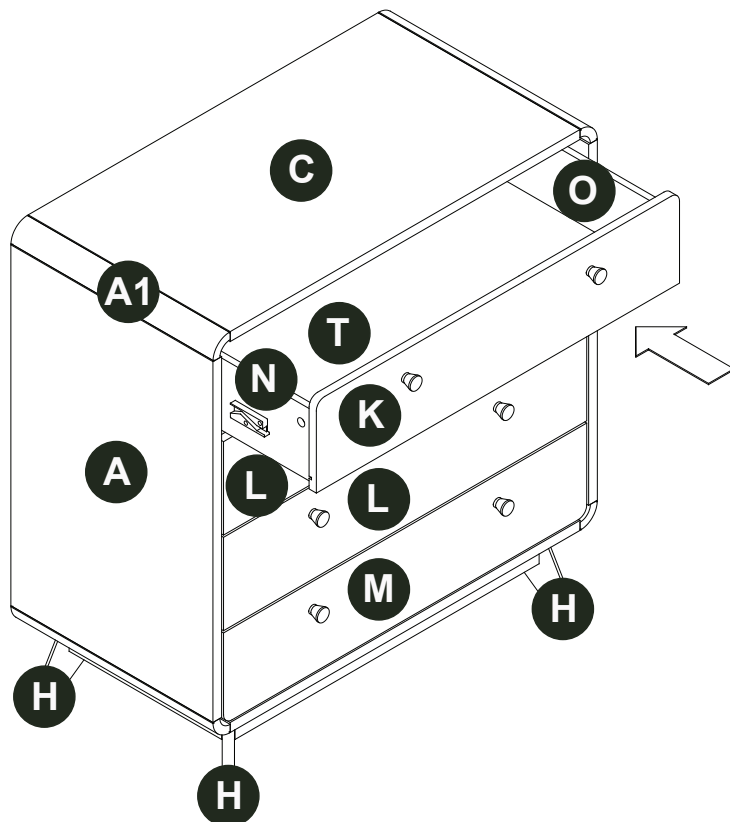
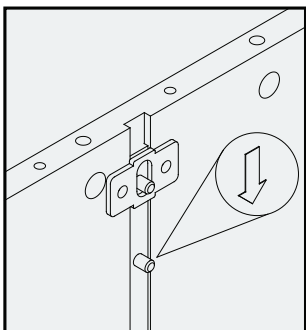

Step 24

Insert the drawer one by one and make sure the roller is on each side of the drawer slide. Please make sure the lever is push down before inserting each drawer.

⚠ CAUTION: This unit is intended for use only with the products and/or maximum weights indicated. Use with other products and/or products heavier than the maximum weights indicated may result in instability or cause possible injury.



⚠ Weight Limit: 50.7lb / 23kg (Middle part)

Helpful Hints

- Move your new furniture carefully, with two people lifting and carrying the unit to its new location.
- Your furniture can be disassembled and reassembled to move.
- Clean the product with a soft damp cloth. DO NOT use harsh chemicals or abrasive cleaners.
- Check bolts and nuts periodically and tighten if necessary.

That's it ! You've finished assembling your

4 DRAWER DRESSER!

CÓMODA 4 CAJONES

Información sobre la garantía

garantiza que este producto está libre de defectos de material y mano de obra y se compromete a remediar cualquier defecto de este tipo. Esta garantía cubre 1 año a partir de la fecha de compra original. Esta garantía es válida solamente con presentación de una prueba de compra. Esto se limita a la reparación o reemplazo de componentes defectuosos del mueble y no se incluye ningún trabajo de ensamblaje.

Esta garantía no se aplica a ningún producto que haya sido mal ensamblado, sujeto a mal uso o abuso, o que haya sido alterado o reparado de cualquier manera. Cualquier uso, rotura o pérdida de color de la tela no están incluidos en esta garantía (donde corresponda). Esta garantía le da derechos legales específicas y usted puede también tener otros derechos que varían de estado a estado o de provincia a provincia.

Para obtener el servicio de garantía, debe presentar la factura original de su compra. Los componentes reparados o reemplazados están garantizados durante el periodo original de la garantía. Las partes defectuosas serán reparadas o reemplazadas sin cargo extra y sujetas a los términos y condiciones descritos anteriormente. Los términos y condiciones de la garantía limitada están sujetos a cambios sin previo aviso.

Precauciones

- Este producto está diseñado para uso doméstico y no para uso comercial.
- **ADVERTENCIA PARA NIÑOS PEQUEÑOS** - Este producto contiene componentes pequeños. Por favor asegúrese de que las piezas estén fuera del alcance de los niños.
- No utilice herramientas eléctricas para ensamblar su mueble. Este tipo de herramientas pueden rasgar o dañar las partes.



ESTE INSTRUCTIVO CONTIENE INFORMACION **IMPORTANTE** DE SEGURIDAD. POR FAVOR LEA Y GUARDE PARA SU REFERENCIA FUTURA.

Lea antes de comenzar a ensamblar

- Llame a nuestro número gratuito si necesita asistencia.
- Trabaje en un área espaciosa y cerca de donde su producto será utilizado, preferiblemente sobre una alfombra o utilice el cartón del empaque para proteger su piso y su producto.
- **El número de personas recomendadas para el montaje de este producto es: 2** (sin embargo es recomendable contar con ayuda adicional).
- **Tiempo estimado de ensamble es 1:30 hora.**
- Asegúrese de que todas las partes están incluidas. La mayoría de las partes están etiquetadas o selladas en los bordes.
- Lea cada paso cuidadosamente. Es muy importante que cada paso de las instrucciones sea realizado en el orden correcto. Si estos pasos no se siguen en secuencia, pueden ocurrir dificultades durante el ensamblado.



Partes

IMPORTANTE: La lista de números de piezas que aparece a continuación es exclusiva de su producto. Por favor, manténgalo a mano cuando solicite piezas de repuesto.

 Todo se incluye en 1/1 caja(s) grande(s)!

 Antes de deshacerse de las cajas de cartón, asegúrese de que estén vacías. También confirme que ha recibido todos los componentes necesarios para el ensamblaje al compararlos con la tabla de piezas indicadas en la sección en inglés.

Paquete de componentes

(Oak/Black)		HP# : TU5675611-01
(Walnut/Walnut)		HP# : TU5675877-01
(Paloma Grey)		HP# : TU5675622-01

 **Nota:** Por favor apriete completamente los pernos durante el ensamblaje, apriételes en la última etapa del ensamblaje, a menos que este indicado específicamente en alguna etapa de las instrucciones.

 Los tornillo(s), perno(s) que se utilizan en cada paso se muestran en tamaño real en la esquina inferior derecha de cada página.

NÚMERO DE PIEZAS				
ETIQUETA DE PIEZAS	DESCRIPCIÓN	(Oak/Black)	(Walnut/Walnut)	(Paloma Grey)
A	Panel lateral izquierdo	U5675611-A	U5675877-A	U5675622-A
B	Panel lateral derecho	U5675611-B	U5675877-B	U5675622-B
C	Panel superior	U5675611-C	U5675877-C	U5675622-C
D	Panel inferior	U5675611-D	U5675877-D	U5675622-D
E	Panel de soporte superior/inferior	U5675611-E	U5675877-E	U5675622-E
F	Panel frontal de soporte	U5675611-F	U5675877-F	U5675622-F
G	Panel de soporte trasero	U5675611-G	U5675877-G	U5675622-G
H	Panel de pierna	U5675611-H	U5675877-H	U5675622-H
I	Panel de marco de pierna	U5675611-I	U5675877-I	U5675622-I
J	Panel lateral del marco de la pierna	U5675611-J	U5675877-J	U5675622-J
K	Parte superior frontal del cajón	U5675611-K	U5675877-K	U5675622-K
L	Centro frontal del cajón	U5675611-L	U5675877-L	U5675622-L
M	Frente del cajón inferior	U5675611-M	U5675877-M	U5675622-M
N	Lado del cajón derecho	U5675611-N	U5675877-N	U5675622-N
O	Lado del cajón izquierdo	U5675611-O	U5675877-O	U5675622-O
P	Parte trasera del cajón	U5675611-P	U5675877-P	U5675622-P
Q	Soporte de cajón	U5675611-Q	U5675877-Q	U5675622-Q
R	Panel trasero superior	U5675611-R	U5675877-R	U5675622-R
S	Panel trasero inferior	U5675611-S	U5675877-S	U5675622-S
T	Fondo del cajón	U5675611-T	U5675877-T	U5675622-T
A1	Panel de perfil lateral	U5675611-A1	U5675877-A1	U5675622-A1
B1	Panel de perfil lateral	U5675611-B1	U5675877-B1	U5675622-B1

Instrucciones

- Paso 1** Inserte la clavija (4) en cada panel como se muestra a la izquierda.
- Paso 2** Insertar el minifix (1) y luego apretarlo con un destornillador. Luego alinee el soporte de montaje en L (15) y luego apriete con el tornillo (16).
- Paso 3** Fije el panel lateral del cajón N y O al respaldo del cajón P y luego apriételo con el tornillo (6).
- Paso 4** Inserte la parte inferior del cajón T entre los lados N y O del cajón y luego continúe con el soporte del cajón Q.
- Paso 5** Inserte la leva (3) en cada panel y apriételo todo en consecuencia. Antes de colocar el otro panel, coloque una pequeña gota de pegamento (19) en el orificio de la clavija de madera.
- Paso 6** Al colocar la guía del cajón (9), asegúrese de que el rodillo deslizante del cajón esté orientado hacia la parte posterior del cajón como se muestra a la izquierda y luego apriételo con el tornillo (5).
- Paso 7** Utilice el tornillo (12) y el pomo de madera (11) y luego apriételo con un destornillador.
- Paso 8** Inserte la leva (3) en cada panel y apriételo todo en consecuencia. Antes de colocar el otro panel, coloque una pequeña gota de pegamento (19) en el orificio de la clavija de madera.
- Paso 9** Inserte la leva (3) en cada panel y apriételo todo en consecuencia. Antes de colocar el otro panel, coloque una pequeña gota de pegamento (19) en el orificio de la clavija de madera.
- Paso 10** Inserte la leva (3) en cada panel y apriételo todo en consecuencia. Antes de colocar el otro panel, coloque una pequeña gota de pegamento (19) en el orificio de la clavija de madera.
- Paso 11** Inserte la leva (3) en cada panel y apriételo todo en consecuencia. Antes de colocar el otro panel, coloque una pequeña gota de pegamento (19) en el orificio de la clavija de madera.
- Paso 12** Inserte el tornillo (7) en el panel E y apriételo todo como se muestra.
- Paso 13** Adjuntó el panel del marco de la pierna J y el panel inferior D. Antes de colocar el otro panel, coloque una pequeña gota de pegamento (19) en el orificio de la clavija de madera.
- Paso 14** Inserte la leva (3) en cada panel y apriételo todo en consecuencia. Antes de colocar el otro panel, coloque una pequeña gota de pegamento (19) en el orificio de la clavija de madera.
- Paso 15** Fije la pata H al panel inferior D y apriete con el tornillo (10).

Paso 16 Coloque el soporte de la esquina de la mesa (13) en el marco de las patas y apriete los tornillos (5) y (7) y asegúrese de colocar el tornillo de acuerdo con la pantalla de pasos.

Paso 17 Adjuntó el panel trasero superior R y el panel trasero inferior S.

Paso 18 Inserte la leva (3) en cada panel y apriételo todo en consecuencia. Antes de colocar el otro panel, coloque una pequeña gota de pegamento (19) en el orificio de la clavija de madera.

Paso 19 Inserte la leva (3) en cada panel y apriételo todo en consecuencia. Antes de colocar el otro panel, coloque una pequeña gota de pegamento (19) en el orificio de la clavija de madera.

Paso 20 Inserte la leva (3) en cada panel y apriételo todo en consecuencia. Antes de colocar el otro panel, coloque una pequeña gota de pegamento (19) en el orificio de la clavija de madera.

Paso 21 Inserte la leva (3) en cada panel y apriételo todo en consecuencia. Antes de colocar el otro panel, coloque una pequeña gota de pegamento (19) en el orificio de la clavija de madera.

Paso 22 Inserte la leva (3) en cada panel y apriételo todo en consecuencia. Antes de colocar el otro panel, coloque una pequeña gota de pegamento (19) en el orificio de la clavija de madera.

Paso 23 Coloque la corredera del cajón (9) y apriétela con el tornillo (8); asegúrese de colocar la corredera del cajón como se muestra.

Paso 24 Inserte el cajón y asegúrese de que el rodillo esté a cada lado de la guía del cajón. Asegúrese de que la palanca esté presionada hacia abajo antes insertando cada cajón.

Consejos útiles

- Mueva sus muebles nuevos con cuidado, se requiere de dos personas para levantar y trasladar su producto a su nueva ubicación.
- Limpie el producto con un paño suave. NO utilice productos químicos o abrasivos de limpieza.
- Revise los tornillos y tuercas periódicamente y apriételos si es necesario.
- Algunas partes han sido pre-ensambladas en este producto. Se encuentran ilustradas en esta página y disponibles para reemplazo (sección en inglés).

 No se apoye ni aplique un peso excesivo sobre el estante de la puerta delantera.

Límite de peso: (Estante de la puerta delantera) 50.7 lbs / 23 kg

PRECAUCIÓN

- La unidad puede volcar causando lesiones graves o la muerte.
- Ancle la unidad a un montante o pared.
- NO permita que los niños se suban al mueble.
- Coloque los objetos pesados en los estantes o cajones inferiores.
- Lea y siga todas las instrucciones de montaje.

COMMODE DROIT 4 TIROIRS



CE FEUILLET CONTIENT DES INFORMATIONS DE SÉCURITÉ **IMPORTANTES**. S'IL VOUS PLAÎT LIRE ET CONSERVER POUR RÉFÉRENCE ULTERIEURE.

Informations sur la garantie

garantit que ce produit est exempt de tout vice de matériaux et de fabrication et s'engage à remédier à un tel défaut. Cette garantie est valable un an à compter de la date d'achat initiale. Elle se limite uniquement à la réparation ou au remplacement des pièces défectueuses. La main-d'oeuvre nécessaire à l'assemblage n'est pas incluse.

Cette garantie ne s'applique pas aux produits qui ont été mal assemblés, qui ont été soumis à une utilisation abusive ou qui ont subi des modifications ou des réparations. La garantie ne couvre pas l'usure, les déchirures ou la décoloration du tissu (le cas échéant). La responsabilité pour les dommages indirects est exclue quand l'exclusion est autorisée par la loi. Cette garantie vous confère des droits spécifiques légaux. Il se peut que vous bénéficiiez de droits additionnels car ceux-ci peuvent varier selon l'État ou la province.

Pour bénéficier du service de garantie, l'acheteur doit présenter la facture originale. Les composants réparés ou remplacés sont garantis jusqu'à la fin de la période de la garantie initiale uniquement. Les composants défectueux seront réparés ou remplacés sans frais, sous réserve des conditions décrites ci-dessus. Les termes et conditions de la garantie limitée sont susceptibles d'être modifiés sans préavis.

Précautions

- Ce produit est conçu pour un usage domestique et n'est pas destiné à des fins commerciales.
- **AVERTISSEMENT CONCERNANT LES JEUNES ENFANTS:** Ce produit contient des petits composants. S'il vous plaît assurez-vous qu'ils soient gardés loin d'eux.
- Ne pas utiliser d'outils électriques pour assembler votre mobilier. Ce type d'outils risque d'endommager les pièces.

Avant de commencer l'assemblage

- Si vous avez besoin d'aide, appelez notre service à la clientèle sans frais.
- Travaillez dans un endroit spacieux et près du lieu où l'unité sera utilisée, préférablement sur un tapis, ou sur un morceau de l'emballage, afin de protéger le plancher et le produit.
- **Nombre de personnes recommandées pour l'assemblage : 2** (cependant il est toujours préférable d'être assisté par une personne supplémentaire).
- **Temps estimé d'assemblage : 1:30 h.**
- Assurez-vous d'avoir bien reçu toutes les pièces. La plupart de celles-ci sont étiquetées ou estampées sur leur côté non fini.
- Lire attentivement chaque étape avant de débiter. Il est très important que chaque étape de montage soit exécutée dans le bon ordre, sinon vous risquez d'éprouver de la difficulté à assembler votre meuble.



Pièces

IMPORTANT: La liste des références ci-dessous est propre à votre produit. Veuillez l'avoir sous la main lorsque vous appelez pour des pièces de rechange.

 Tout dans 1/1 grande(s) boîte(s)!

 Avant de jeter les boîtes en carton, assurez-vous qu'elles soient vides. Vérifiez que vous avez reçu tous les composants nécessaires à l'assemblage en les comparant avec le tableau des pièces (illustrations disponibles dans la section en anglais).

Quincaillerie

(Oak/Black)		HP# : TU5675611-01
(Walnut/Walnut)		HP# : TU5675877-01
(Paloma Grey)		HP# : TU5675622-01

 **Remarque:** Sauf indication contraire dans les instructions, ne pas resserrer complètement les vis et les boulons, jusqu'à ce que l'assemblage soit terminé.

 Les vis et boulons utilisés durant chaque étape sont illustrés en taille réelle au coin inférieur droit de la page.

NÚMERO DE PIEZAS				
ETIQUETA DE PIEZAS	DESCRIPCIÓN	(Oak/Black)	(Walnut/Walnut)	(Paloma Grey)
A	Panneau latéral gauche	U5675611-A	U5675877-A	U5675622-A
B	Panneau latéral droit	U5675611-B	U5675877-B	U5675622-B
C	Panneau du haut	U5675611-C	U5675877-C	U5675622-C
D	Panneau du bas	U5675611-D	U5675877-D	U5675622-D
E	Panneau de support supérieur/inférieur	U5675611-E	U5675877-E	U5675622-E
F	Prise en charge du panneau avant	U5675611-F	U5675877-F	U5675622-F
G	Panneau de support arrière	U5675611-G	U5675877-G	U5675622-G
H	Panneau de jambe	U5675611-H	U5675877-H	U5675622-H
I	Panneau de cadre de jambe	U5675611-I	U5675877-I	U5675622-I
J	Panneau latéral du cadre de jambe	U5675611-J	U5675877-J	U5675622-J
K	Dessus avant du tiroir	U5675611-K	U5675877-K	U5675622-K
L	Centro frontal del cajón	U5675611-L	U5675877-L	U5675622-L
M	Façade du tiroir inférieur	U5675611-M	U5675877-M	U5675622-M
N	Côté droit du tiroir	U5675611-N	U5675877-N	U5675622-N
O	Côté tiroir gauche	U5675611-O	U5675877-O	U5675622-O
P	Dos du tiroir`	U5675611-P	U5675877-P	U5675622-P
Q	Support de tiroir	U5675611-Q	U5675877-Q	U5675622-Q
R	Panneau arrière supérieur	U5675611-R	U5675877-R	U5675622-R
S	Panneau arrière inférieur	U5675611-S	U5675877-S	U5675622-S
T	Fond de tiroir	U5675611-T	U5675877-T	U5675622-T
A1	Panneau de profil latéral	U5675611-A1	U5675877-A1	U5675622-A1
B1	Panneau de profil latéral	U5675611-B1	U5675877-B1	U5675622-B1

Instructions

- Étape 1** Insérez la goupille (4) dans chaque panneau comme indiqué à gauche.
- Étape 2** Insertar el minifix (1) y luego apretarlo con un destornillador. Aligned ensuite le support de montage en L (15), puis serrez avec la vis (16).
- Étape 3** Fixez le panneau latéral du tiroir N et O à l'arrière du tiroir P puis serrez-le avec la vis (6).
- Étape 4** Insérez le bas du tiroir en T entre les côtés N et O du tiroir puis continuez avec le support du tiroir Q.
- Étape 5** Insérez la came (3) dans chaque panneau et serrez en conséquence. Avant de placer l'autre panneau, placez une petite goutte de colle (19) dans le trou de la cheville en bois.
- Étape 6** Lors de l'installation du guide du tiroir (9), assurez-vous que le rouleau coulissant du tiroir fait face à l'arrière du tiroir, comme illustré. illustré à gauche puis serrez-le avec la vis (5).
- Étape 7** Utilisez la vis (12) et le bouton en bois (11) puis serrez-le avec un tournevis.
- Étape 8** Insérez la came (3) dans chaque panneau et serrez en conséquence. Avant de placer l'autre panneau, placez une petite goutte de colle (19) dans le trou de la cheville en bois.
- Étape 9** Insérez la came (3) dans chaque panneau et serrez en conséquence. Avant de placer l'autre panneau, placez une petite goutte de colle (19) dans le trou de la cheville en bois.
- Étape 10** Insérez la came (3) dans chaque panneau et serrez en conséquence. Avant de placer l'autre panneau, placez une petite goutte de colle (19) dans le trou de la cheville en bois.
- Étape 11** Insérez la came (3) dans chaque panneau et serrez en conséquence. Avant de placer l'autre panneau, placez une petite goutte de colle (19) dans le trou de la cheville en bois.
- Étape 12** Insérez la vis (7) dans le panneau E et serrez comme indiqué.
- Étape 13** Fixez le panneau du cadre du pied J et le panneau inférieur D. Avant de placer l'autre panneau, placez une petite goutte de colle (19) dans le trou de la cheville en bois.
- Étape 14** Insérez la came (3) dans chaque panneau et serrez en conséquence. Avant de placer l'autre panneau, placez une petite goutte de colle (19) dans le trou de la cheville en bois.
- Étape 15** Fixez le pied H au panneau inférieur D et serrez avec la vis (10).

Étape 16 Placez le support d'angle de table (13) sur le cadre du pieds et serrez les vis (5) et (7) et assurez-vous de placer la vis selon l'écran des étapes.

Étape 17 Fixez le panneau arrière supérieur R et le panneau arrière inférieur S.

Étape 18 Insérez la came (3) dans chaque panneau et serrez en conséquence. Avant de placer l'autre panneau, placez une petite goutte de colle (19) dans le trou de la cheville en bois.

Étape 19 Insérez la came (3) dans chaque panneau et serrez en conséquence. Avant de placer l'autre panneau, placez une petite goutte de colle (19) dans le trou de la cheville en bois.

Étape 20 Insérez la came (3) dans chaque panneau et serrez en conséquence. Avant de placer l'autre panneau, placez une petite goutte de colle (19) dans le trou de la cheville en bois.

Étape 21 Insérez la came (3) dans chaque panneau et serrez en conséquence. Avant de placer l'autre panneau, placez une petite goutte de colle (19) dans le trou de la cheville en bois.

Étape 22 Insérez la came (3) dans chaque panneau et serrez en conséquence. Avant de placer l'autre panneau, placez une petite goutte de colle (19) dans le trou de la cheville en bois.

Étape 23 Coloque la corredera del cajón (9) y apriétela con el tornillo (8); asegúrese de colocar la corredera del cajón como se muestra.

Étape 24 Insérez le tiroir et assurez-vous que le rouleau est de chaque côté de le guide du tiroir. Assurez-vous que le levier est enfoncé avant en insérant chaque tiroir.

Conseils utiles

- Déplacez votre nouveau mobilier avec soin, nous recommandons deux personnes pour soulever et transporter le mobilier vers son nouvel emplacement.
- Pour le nettoyage, utilisez un linge doux et/ou humide. N'UTILISEZ PAS de produits abrasifs ou chimiques.
- Vérifiez les vis et écrous périodiquement et resserrez-les si nécessaire.
- Certaines pièces de ce produit ont été pré-assemblées. Elles sont illustrées sur cette page (section en anglais) et elles sont disponibles pour un remplacement.

 Ne vous appuyez pas sur la tablette de la porte avant et n'y mettez pas trop de poids!

Limite de poids : (étagère de la porte avant) 50,7 lbs / 23 kg

AVERTISSEMENT

- L'appareil peut basculer et provoquer des blessures graves, voire mortelles.
- Fixez l'appareil à un montant ou à un mur.
- Ne laissez PAS les enfants grimper sur l'appareil.
- Placez les objets lourds sur les étagères ou les tiroirs inférieurs.
- Lisez et suivez toutes les instructions d'assemblage.