

# Upholstered bed

N652P265285 N652P265286

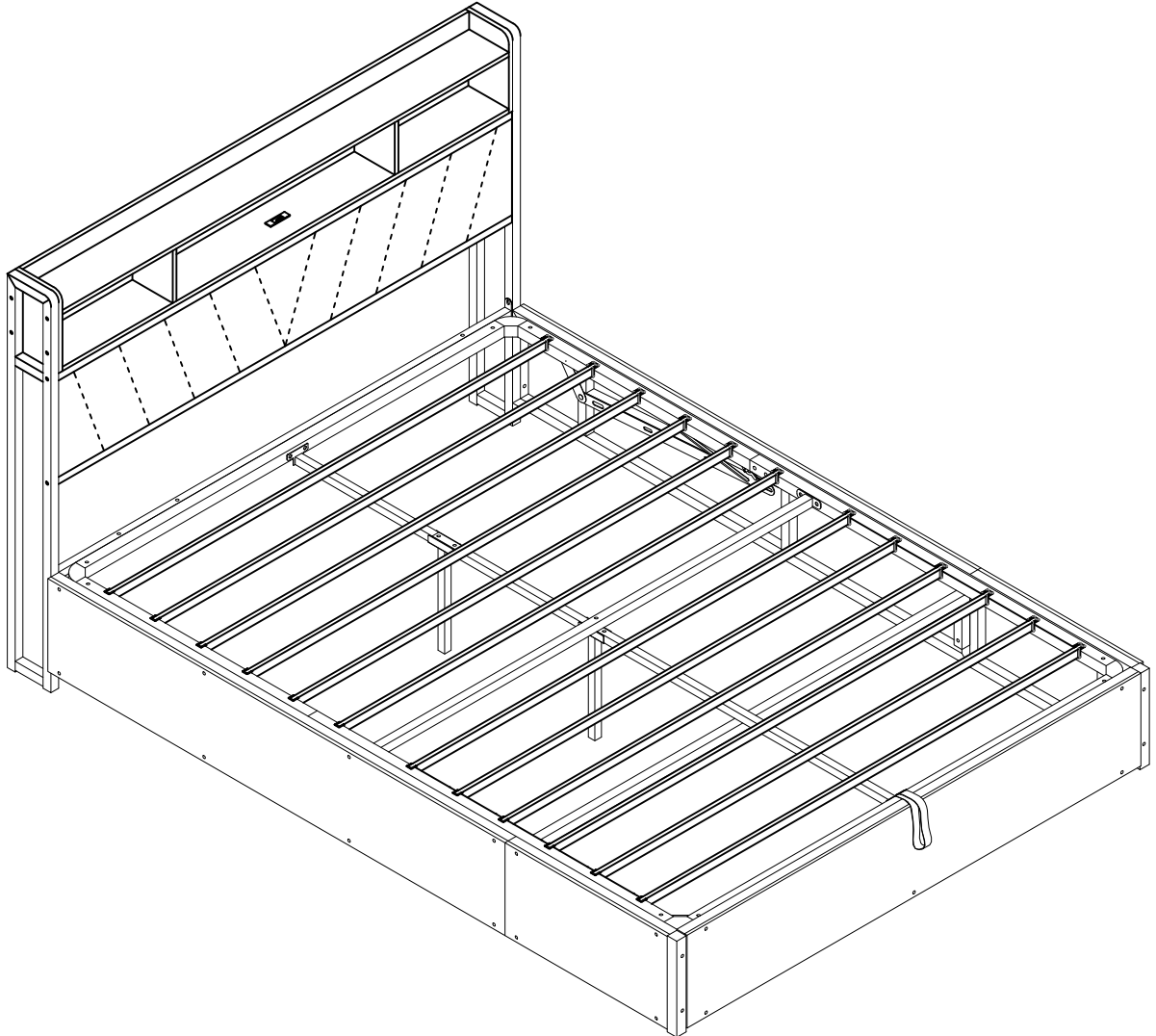

## TIPS

- 1. This product is divided into 2 parcels for delivery. They may not arrive at the same time. Please wait patiently.**
- 2. Please read the instructions fully before assembly. These instructions include important information which could ensure correct assembly. We have been working on providing high quality products for you. However, in the rare instance that your product is defective, missing parts or there are some issues, please don't hesitate to contact our customer service to submit parts requirements, assembly suggestion, or warranty claims, and we will give the best solution as soon as possible. If necessary, we need you to provide some more clear pictures of the issue.**
- 3. Insert the screws in holes and tighten the screws, but not too tight, 70%~80% is ok, finally tighten all the screws. If some issues happened that some screws can not target to the hole or some parts are difficult to install, please adjust the tightness of the screws.**
- 4. 2 people are recommended to finish.**

# SKU: N652P265286

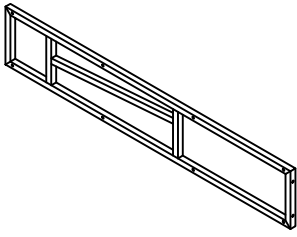

1 1PC

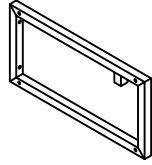

2 1PC

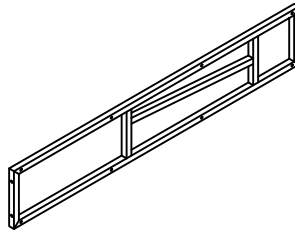

3 1PC

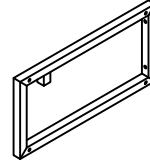

4 1PC

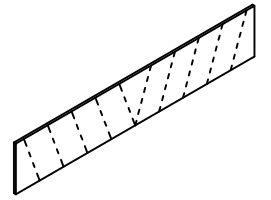

8 1PC

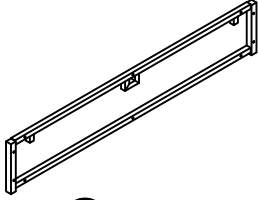

10 1PC



20 4PCS

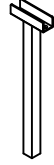

21 2PCS

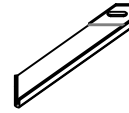

27 2PCS



28 2PCS



30 2PCS

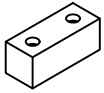

38 1PC

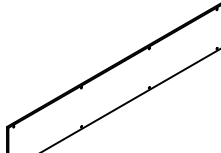

39 2PCS

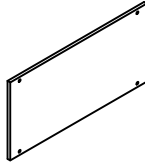

40 2PCS

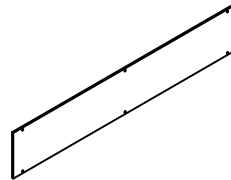

41 1PC

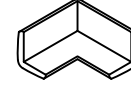

42 2PCS

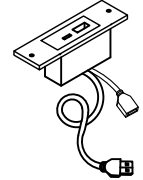

43 1PC

## Sheet accessories

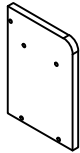

31 1PC

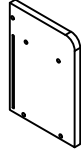

32 1PC

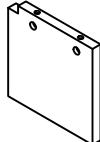

33 2PCS

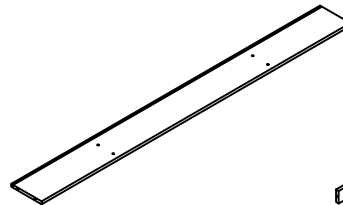

34 1PC

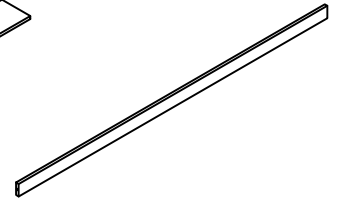

35 1PC

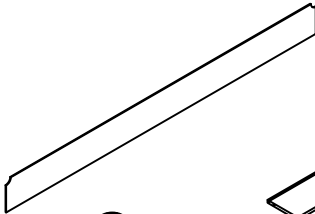

36 1PC

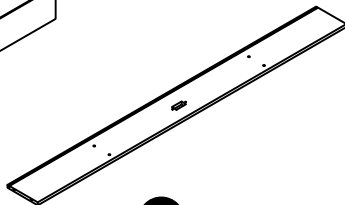

37 1PC

**Hardware parts 2**

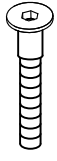

**M**

M5\*35  
X18+1



**N**

M3  
X1



**O**

X4



**P**

X4

**LED light strip electronic accessories list**

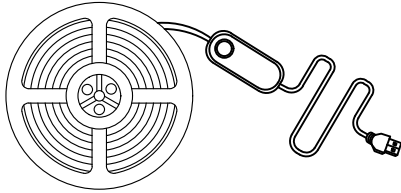

**Light bar X1**

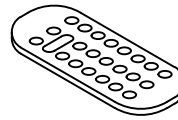

**Remote control X1**

# SKU: N652P265285

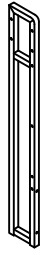

**5** 1PC



**6** 1PC

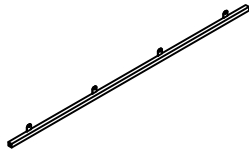

**7** 2PCS

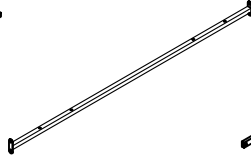

**9** 1PC

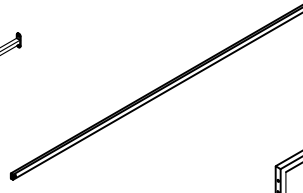

**11** 12PCS

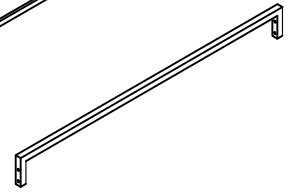

**12** 1PC

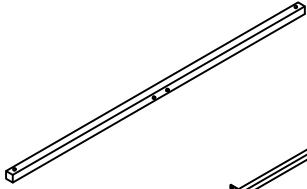

**13** 2PCS

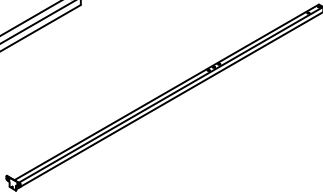

**14** 1PC

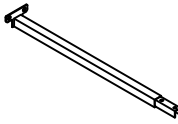

**15** 1PC

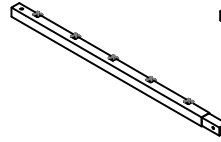

**16** 1PC

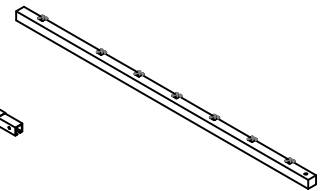

**17** 1PC

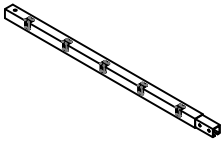

**18** 1PC

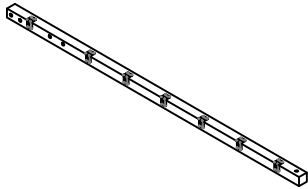

**19** 1PC



**22** 1PC

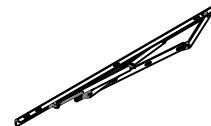

**23** 1PC

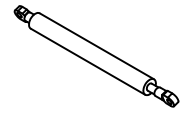

**24** 2PCS



**25** 1PC

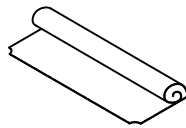

**26** 1PC

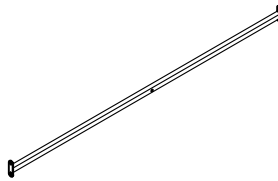

**29** 1PC

## Hardware parts 1

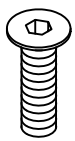

**A**  
M6\*20  
X4+1

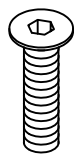

**B**  
M6\*33  
X8+1

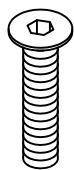

**C**  
M6\*45  
X4+1

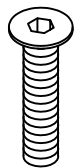

**D**  
M8\*15  
X20+2

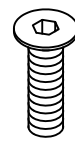

**E**  
M8\*20  
X58+8

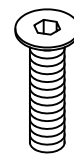

**F**  
M8\*35  
X4+1

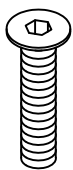

**G**  
M8\*45  
X19+2

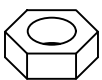

**H**  
M8  
X4+1



**I**  
X1

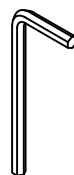

**J**  
M5  
X1

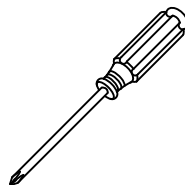

**K**  
X1



**L**  
M3\*12  
X2+1

# Upholstered bed

# OVERVIEW

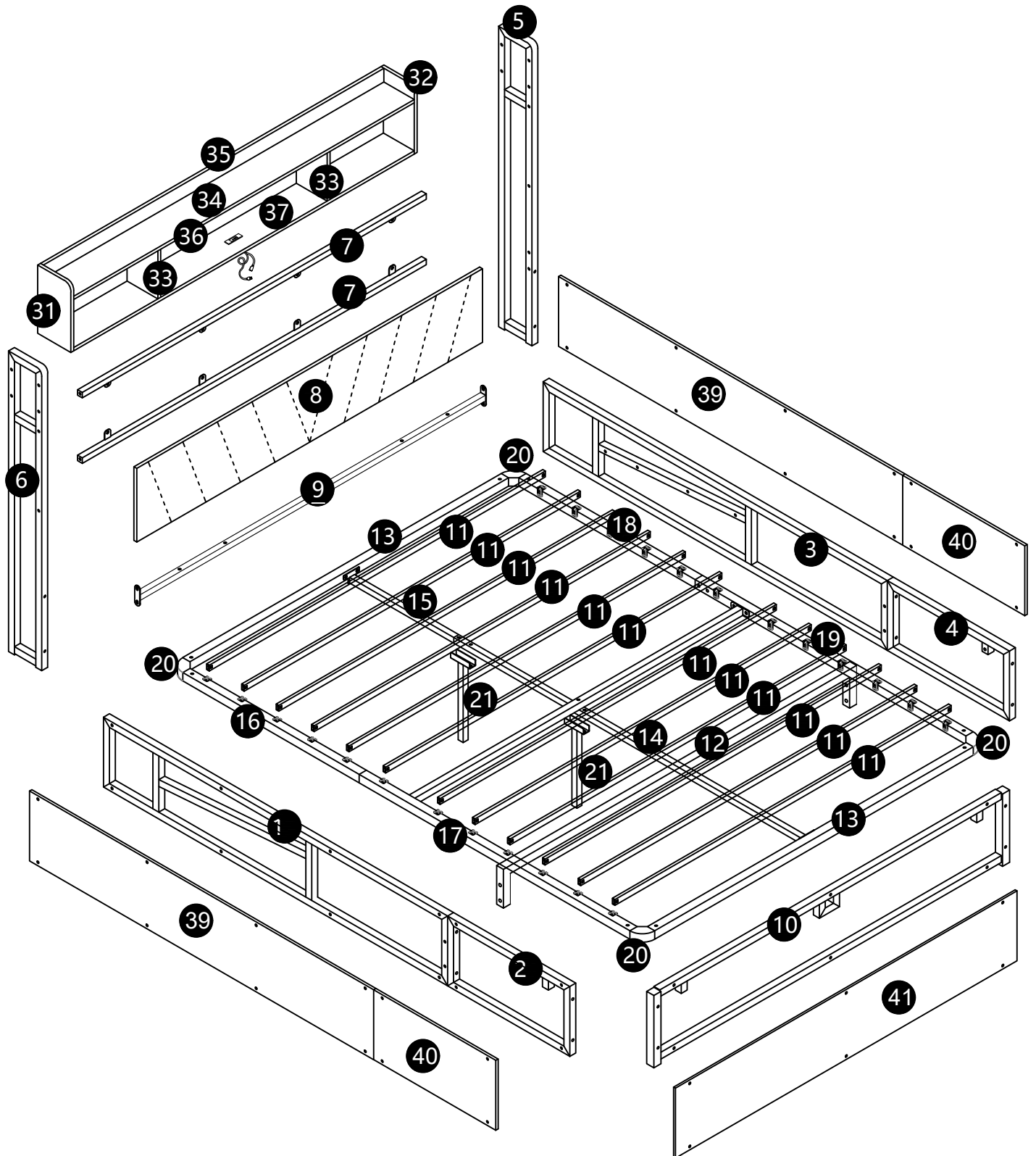

# Upholstered bed

1

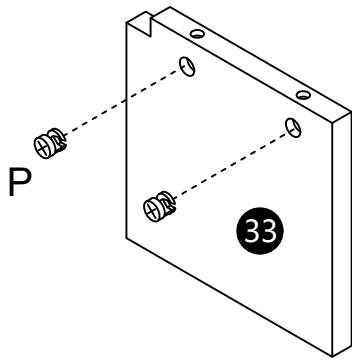
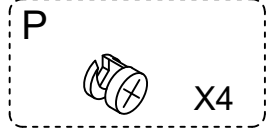
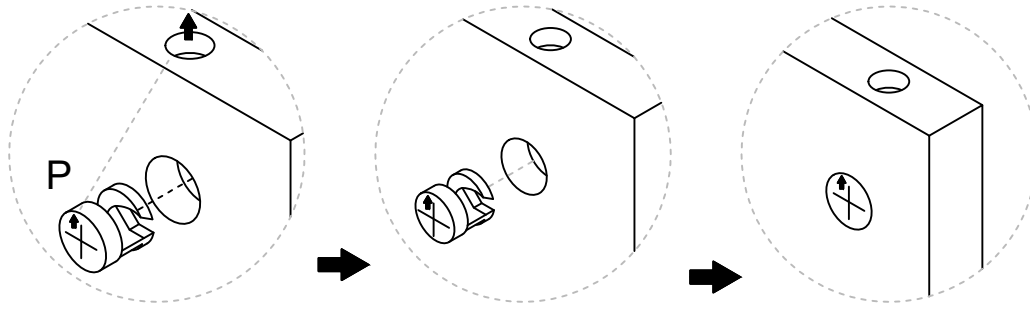

**X2**

1.As shown in the figure, just put the nut ( **P** ) in first. If the nut falls off before locking, insert it back.

2.There is an arrow on the nut. Please align the arrow with the side hole

2

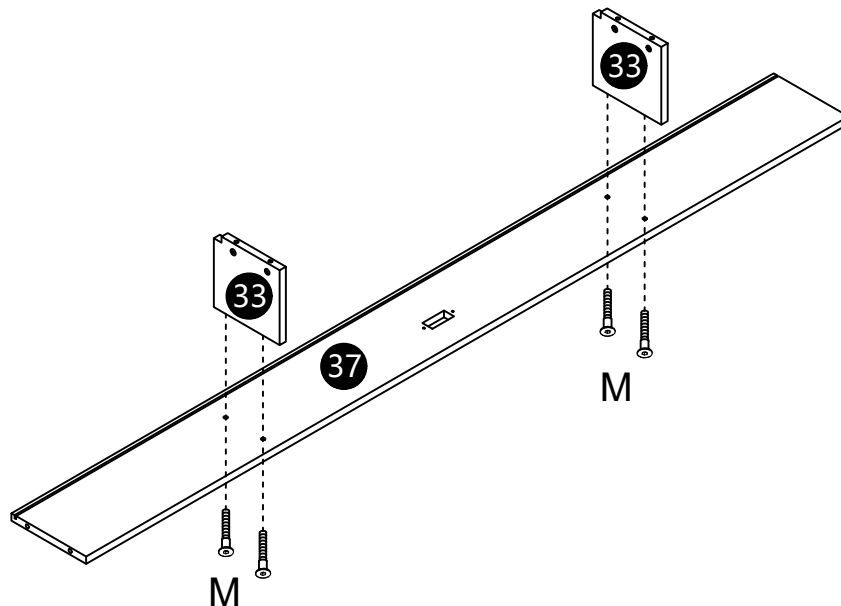
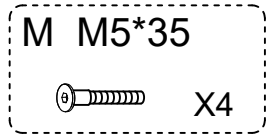

# Upholstered bed

3

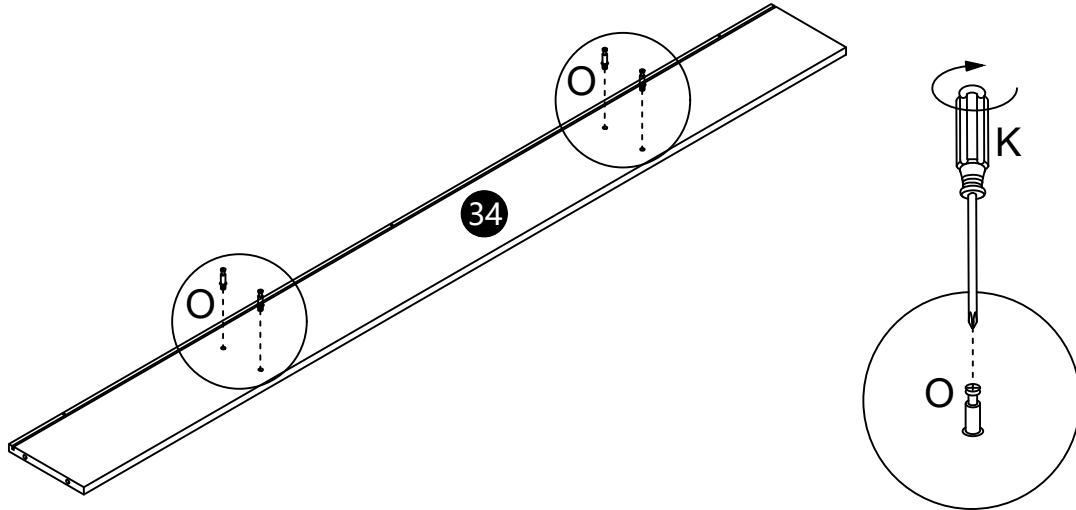
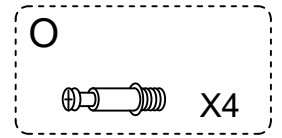

4

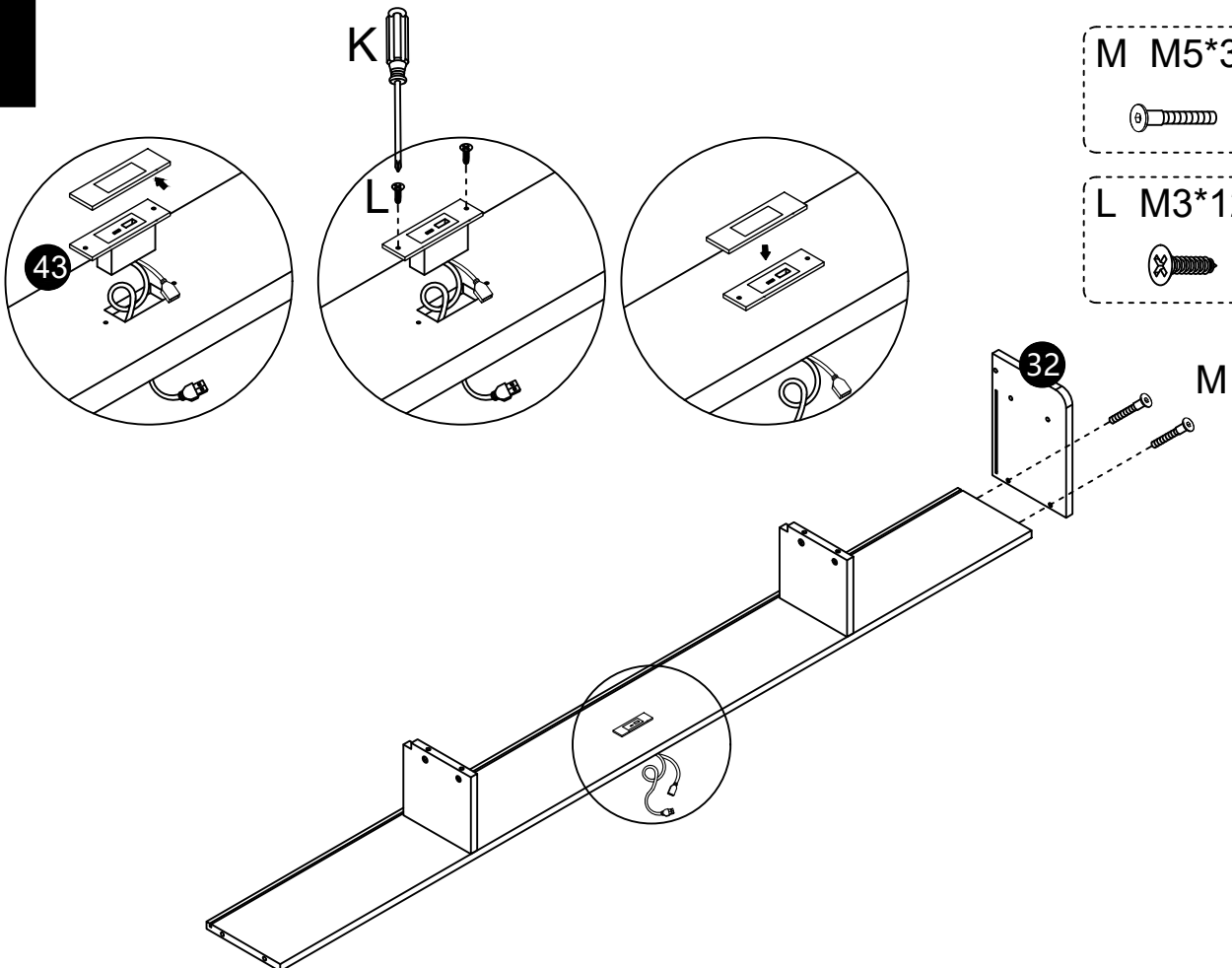
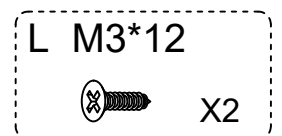
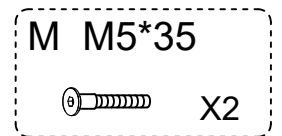

# Upholstered bed

5

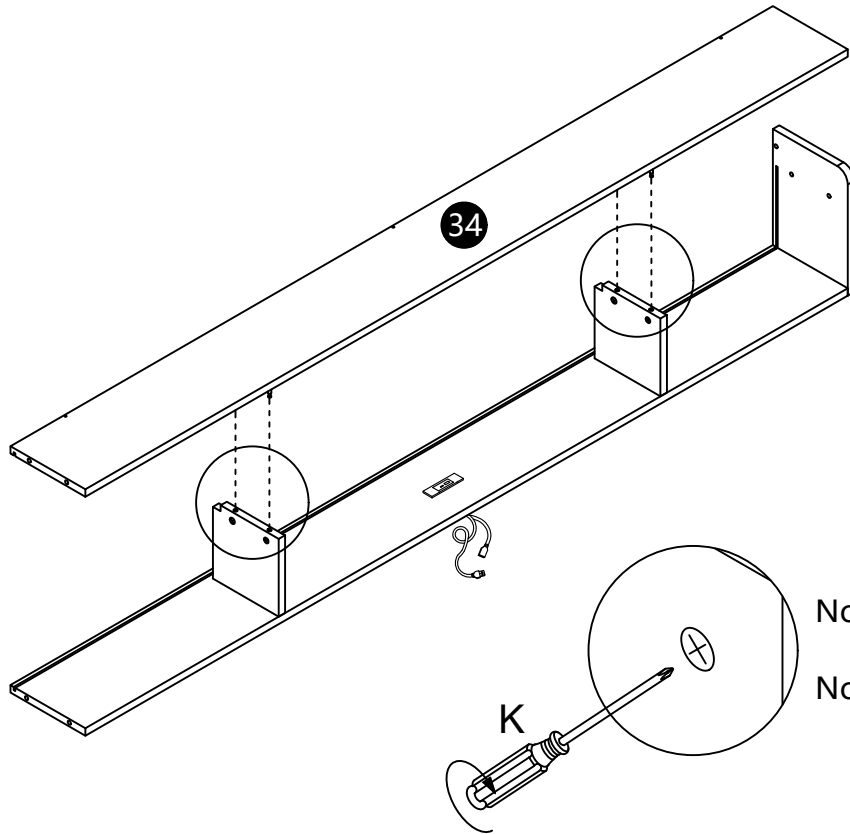

6

M M5\*35  
X6

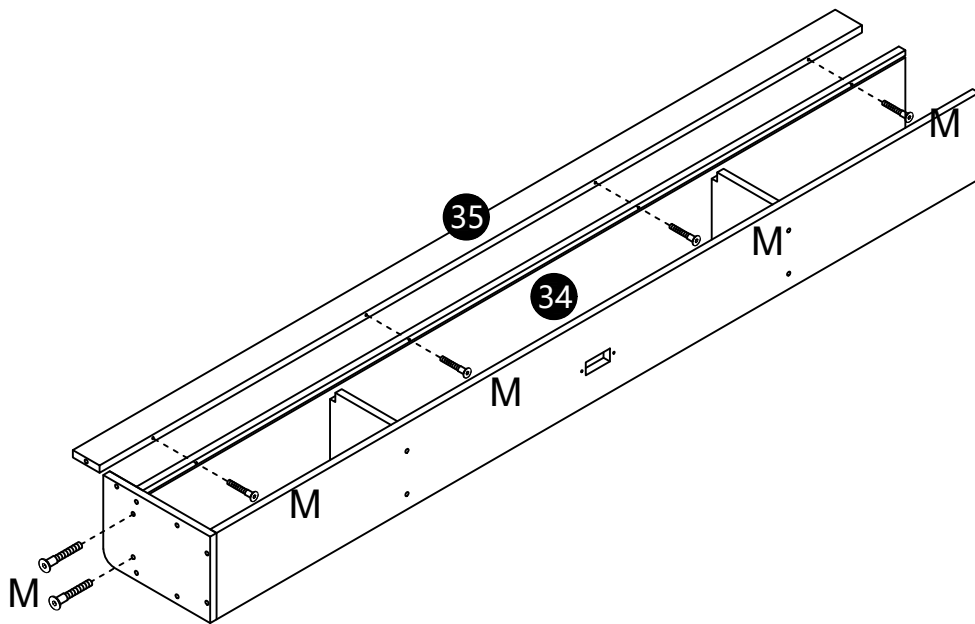

# Upholstered bed

7

M M5\*35

 X1

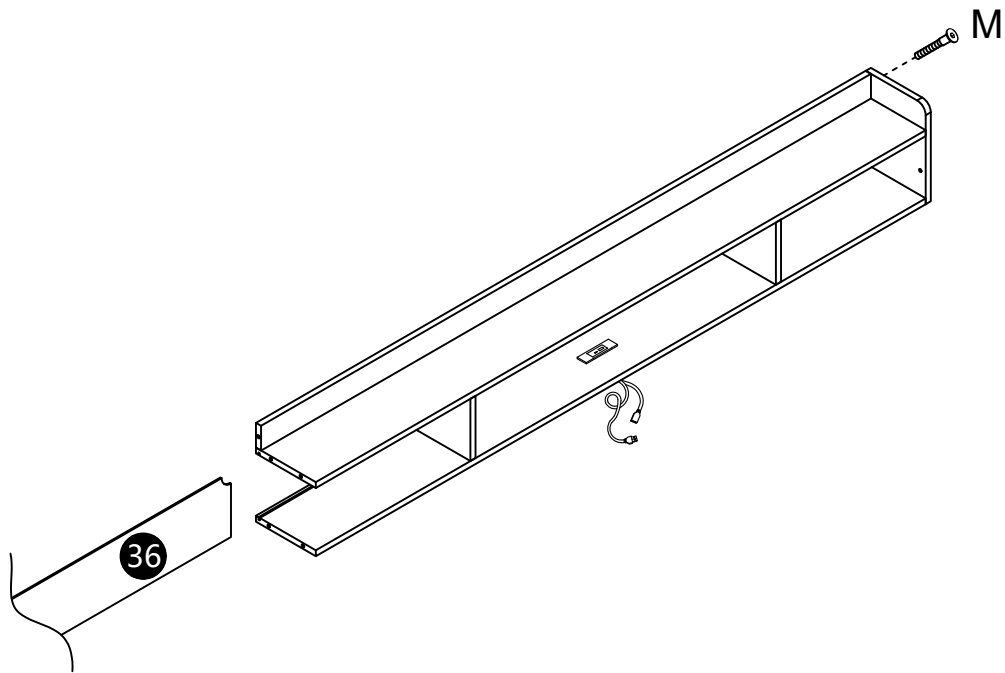

8

M M5\*35

 X5

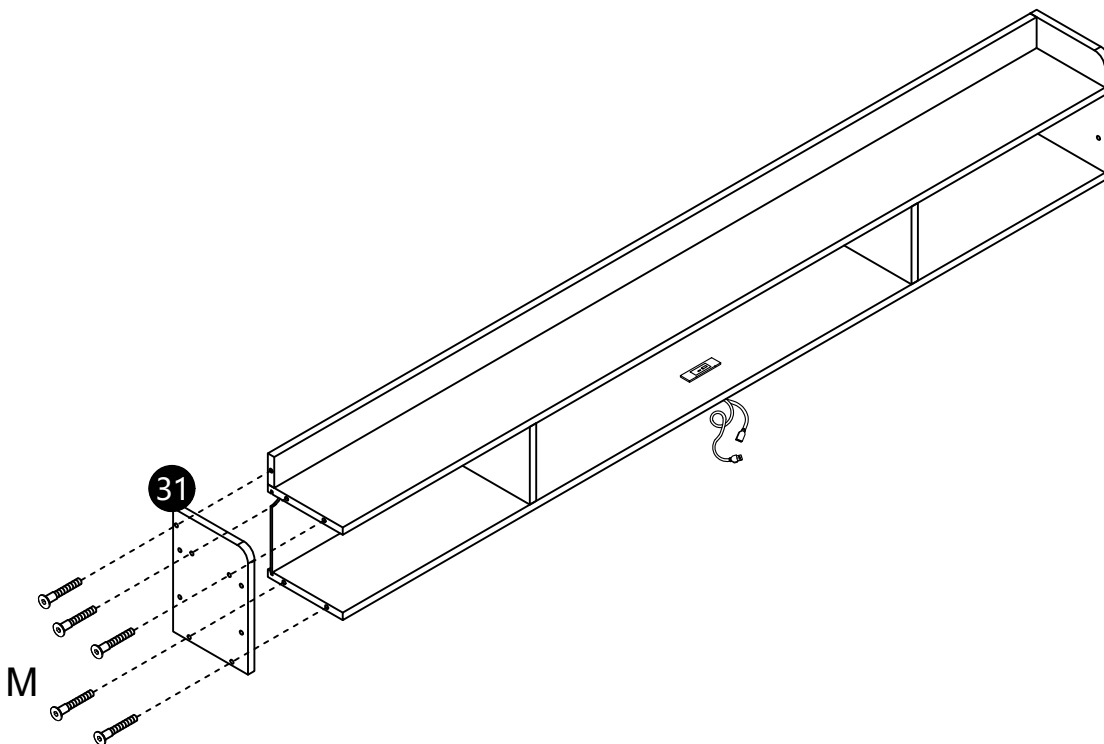

# Upholstered bed

9

C M6\*45

 X4

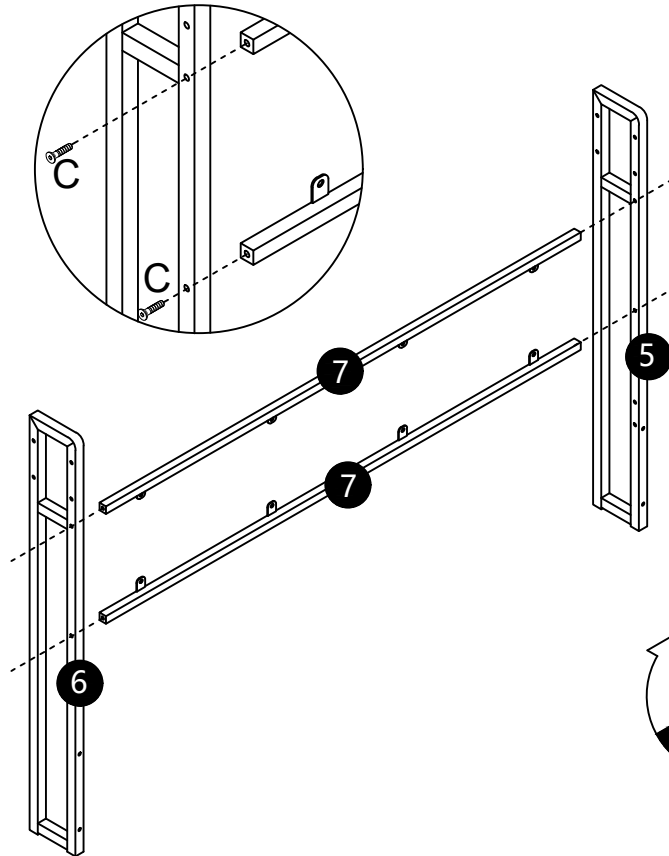

10

B M6\*33

 X8

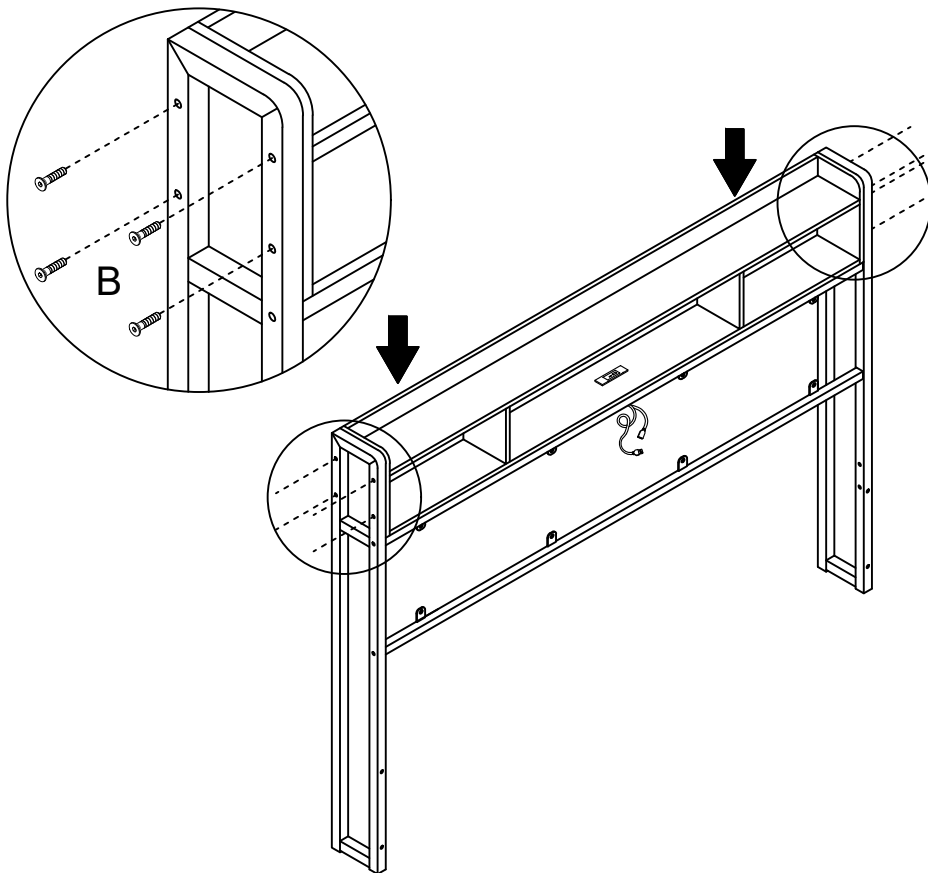

# Upholstered bed

11

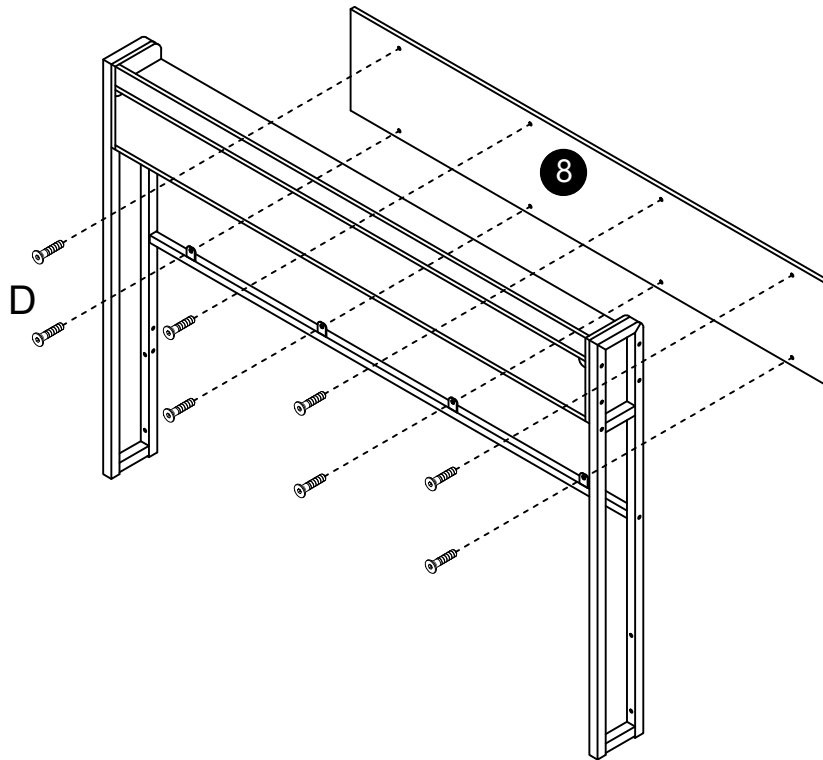

D M8\*15



12

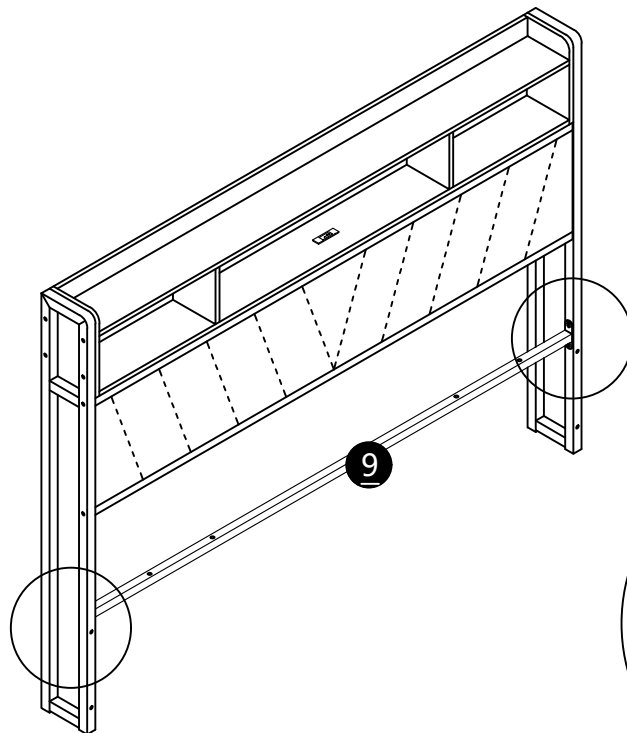

E M8\*20

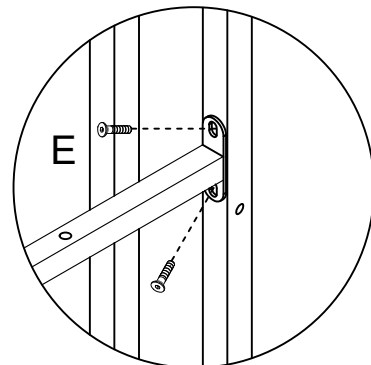

# Upholstered bed

13

E M8\*20  
 X30

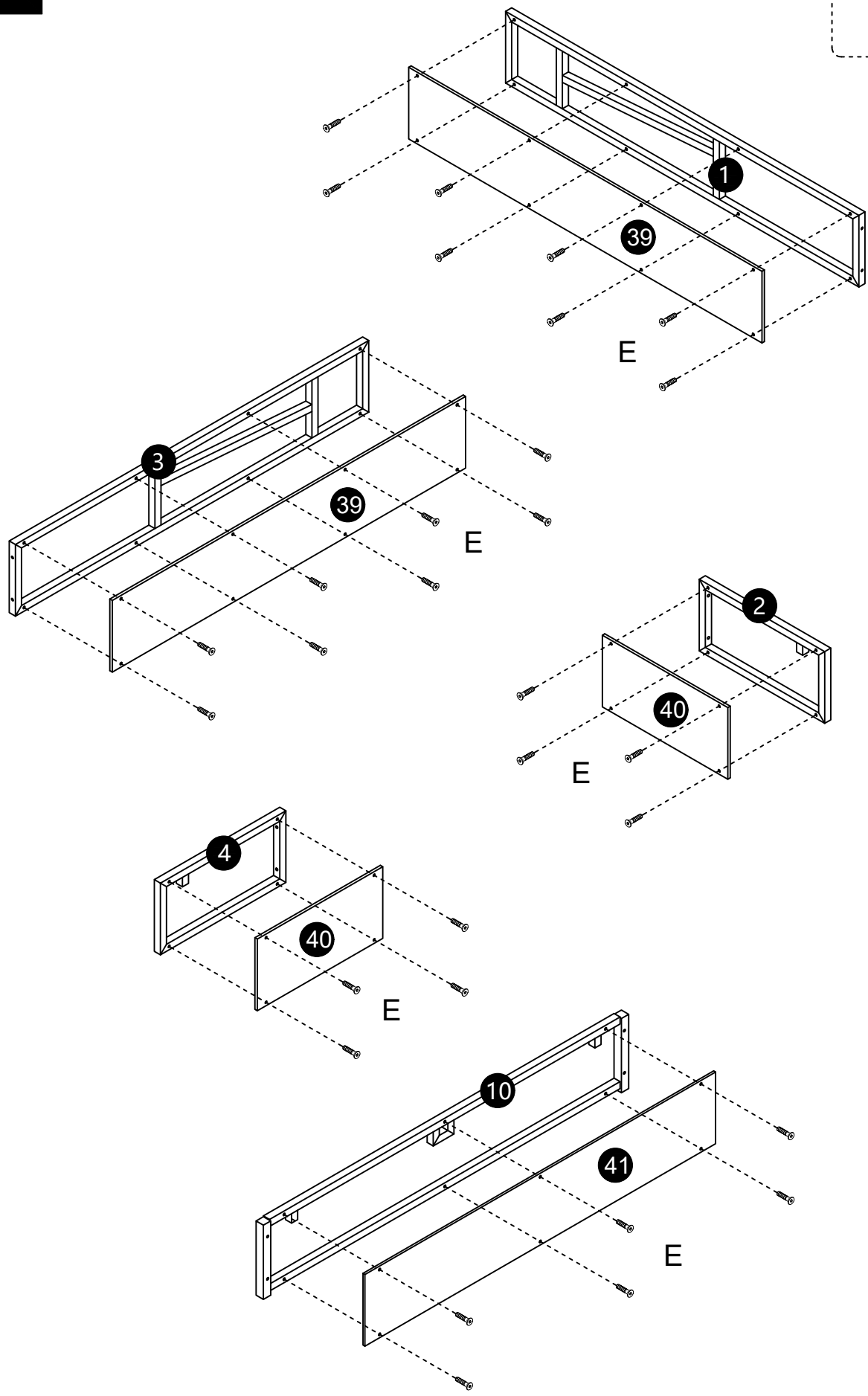

# Upholstered bed

14

G M8\*45  
 X4

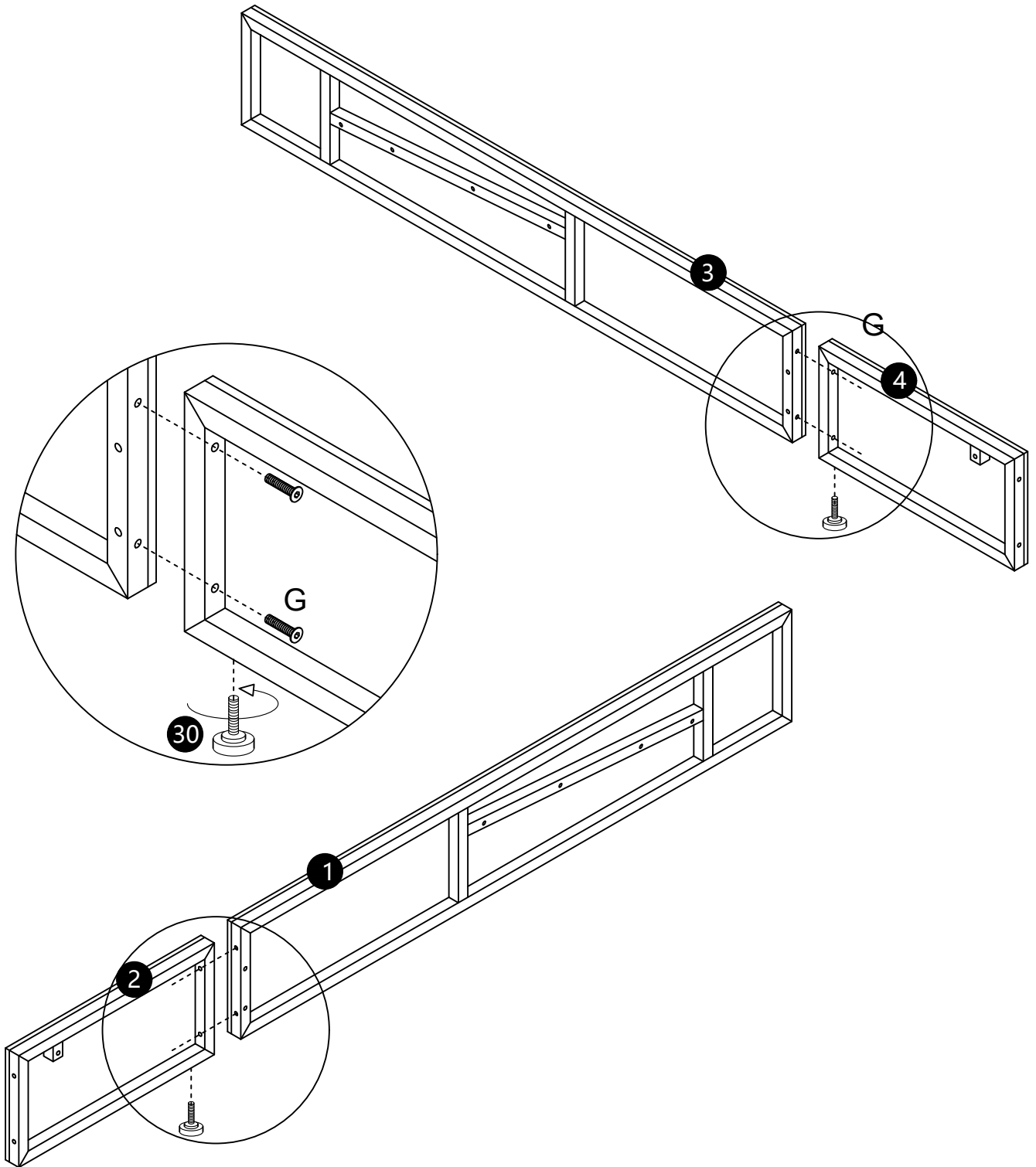

# Upholstered bed

15

G M8\*45  
X10

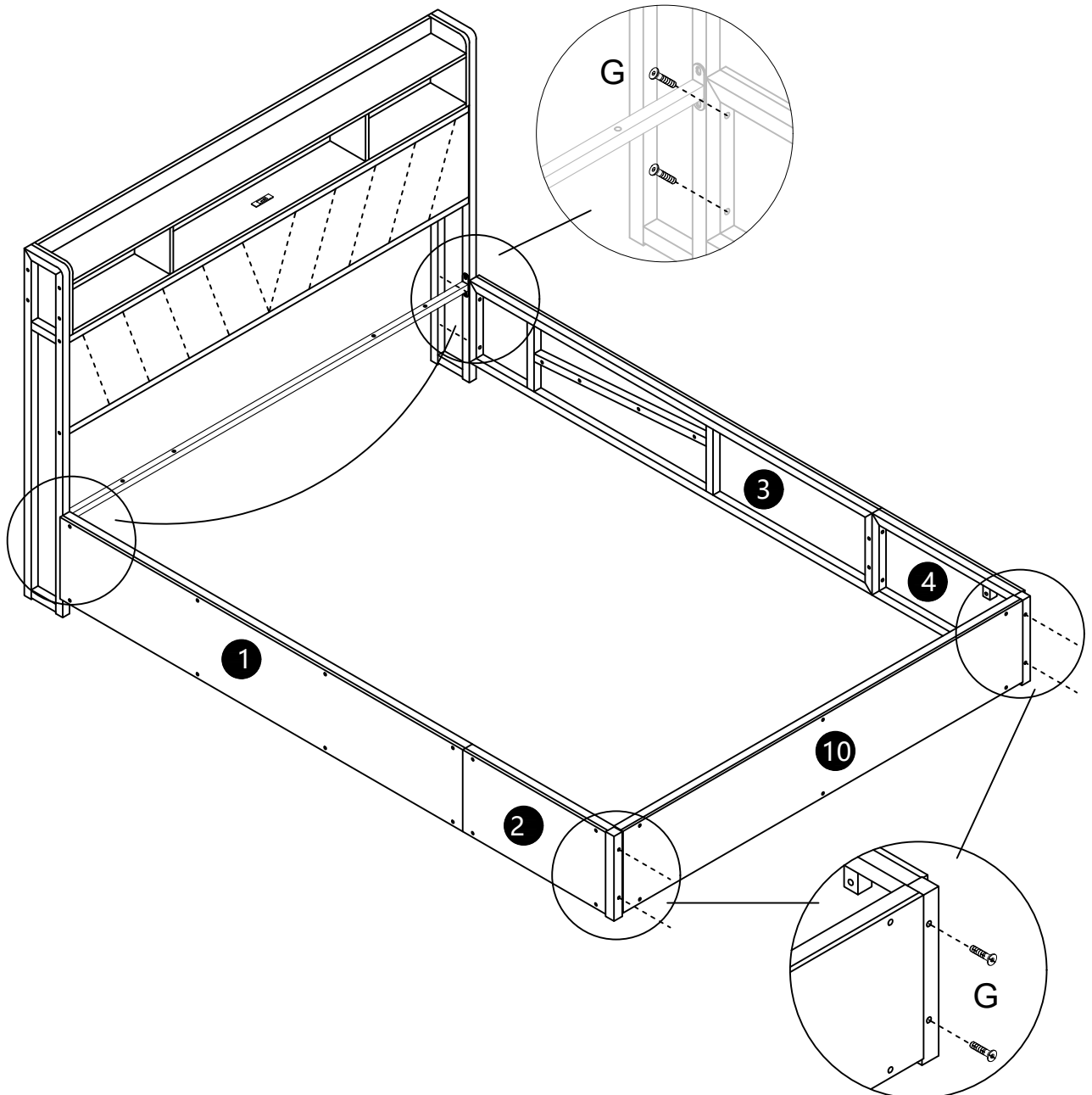
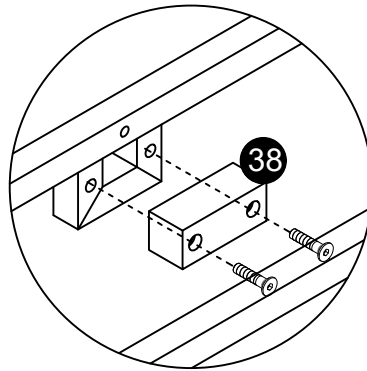
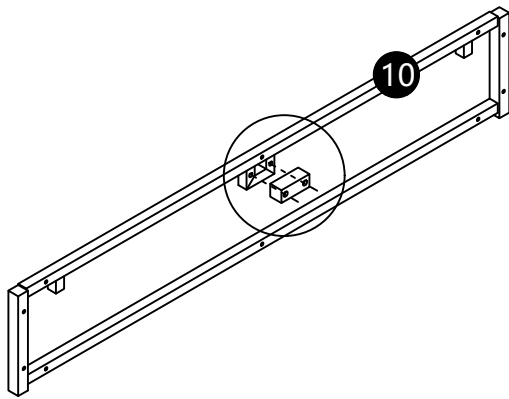

# Upholstered bed

16

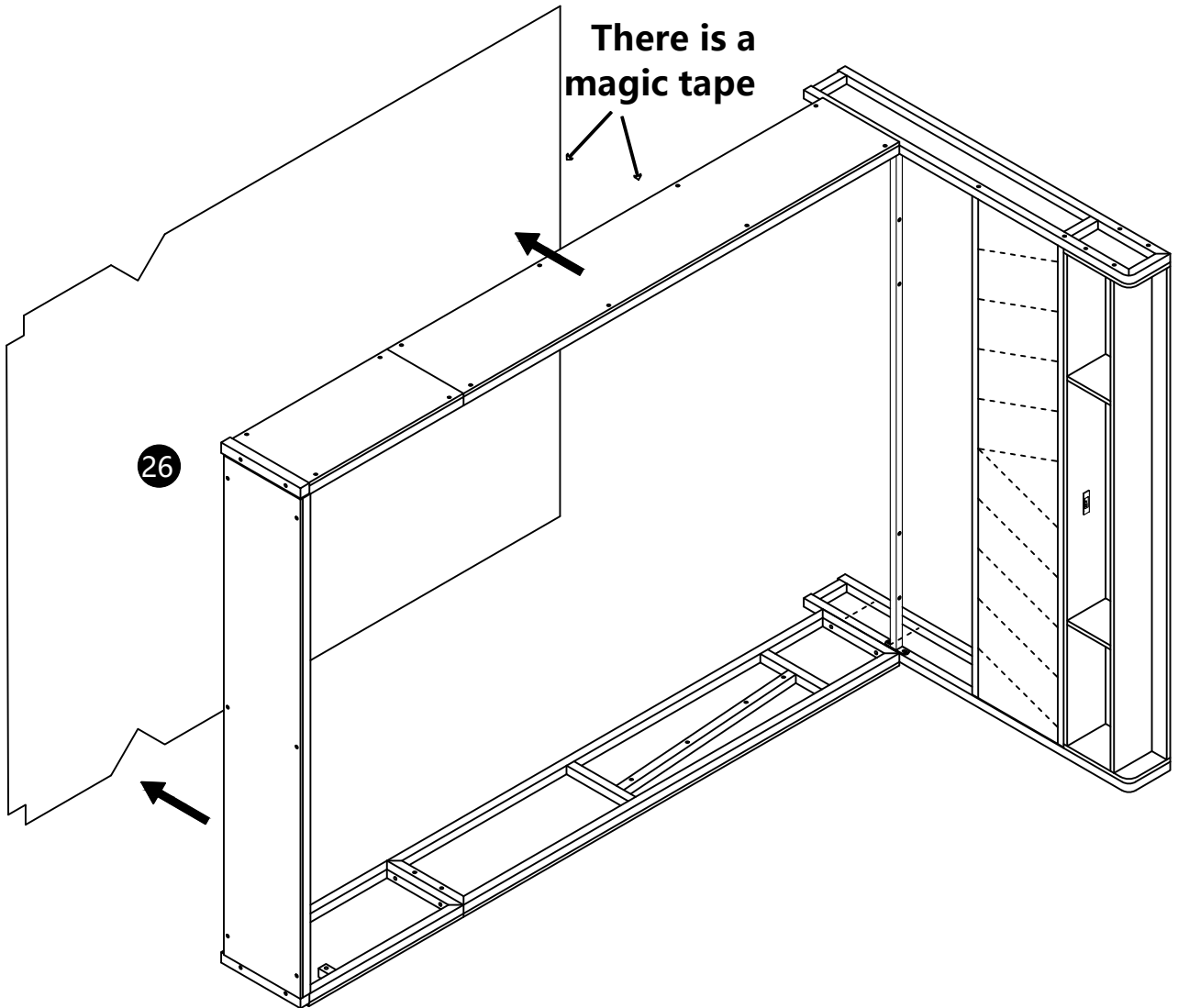

# Upholstered bed

17

A M6\*20

 X4

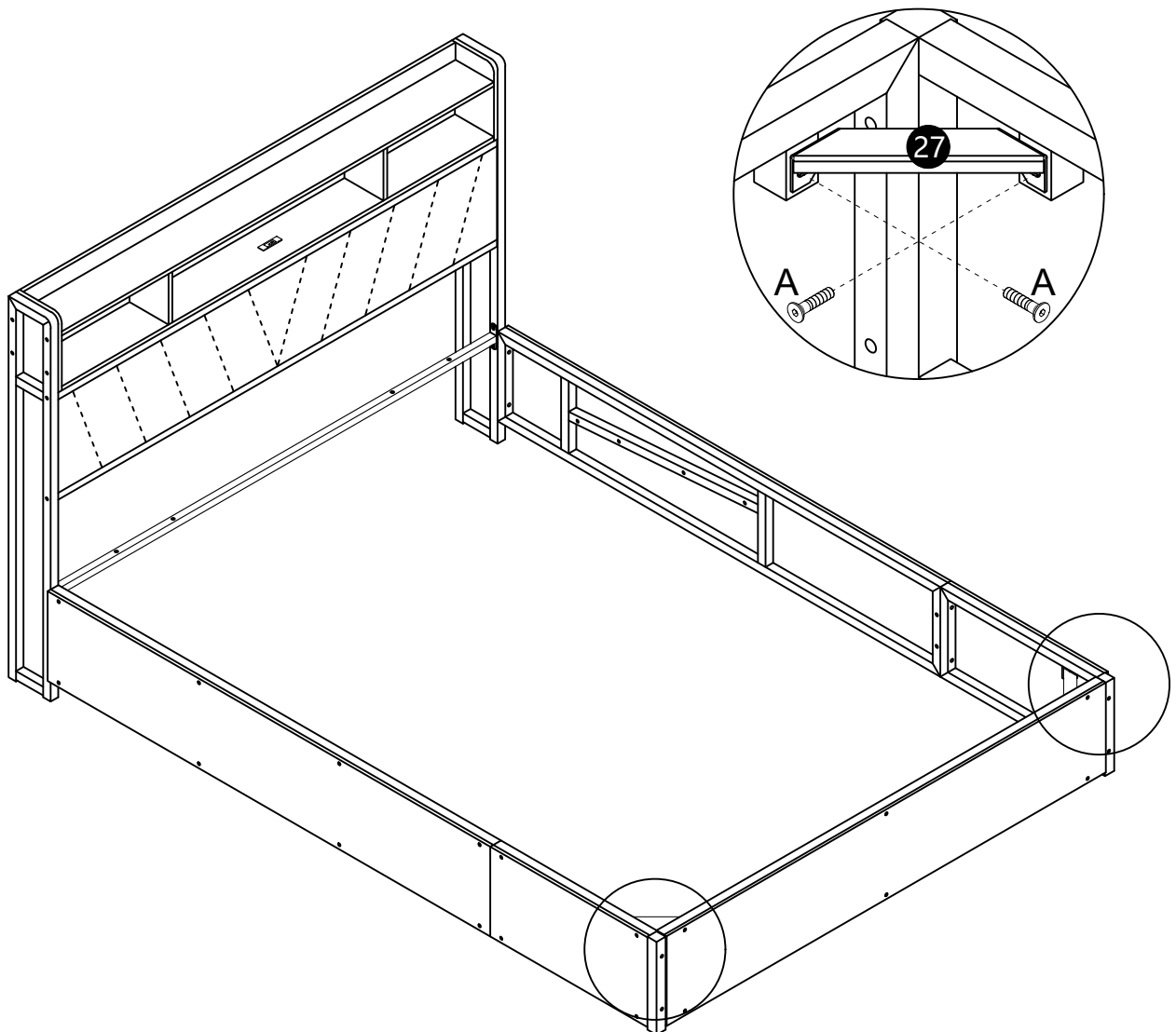

# Upholstered bed

18

G M8\*45

 X4

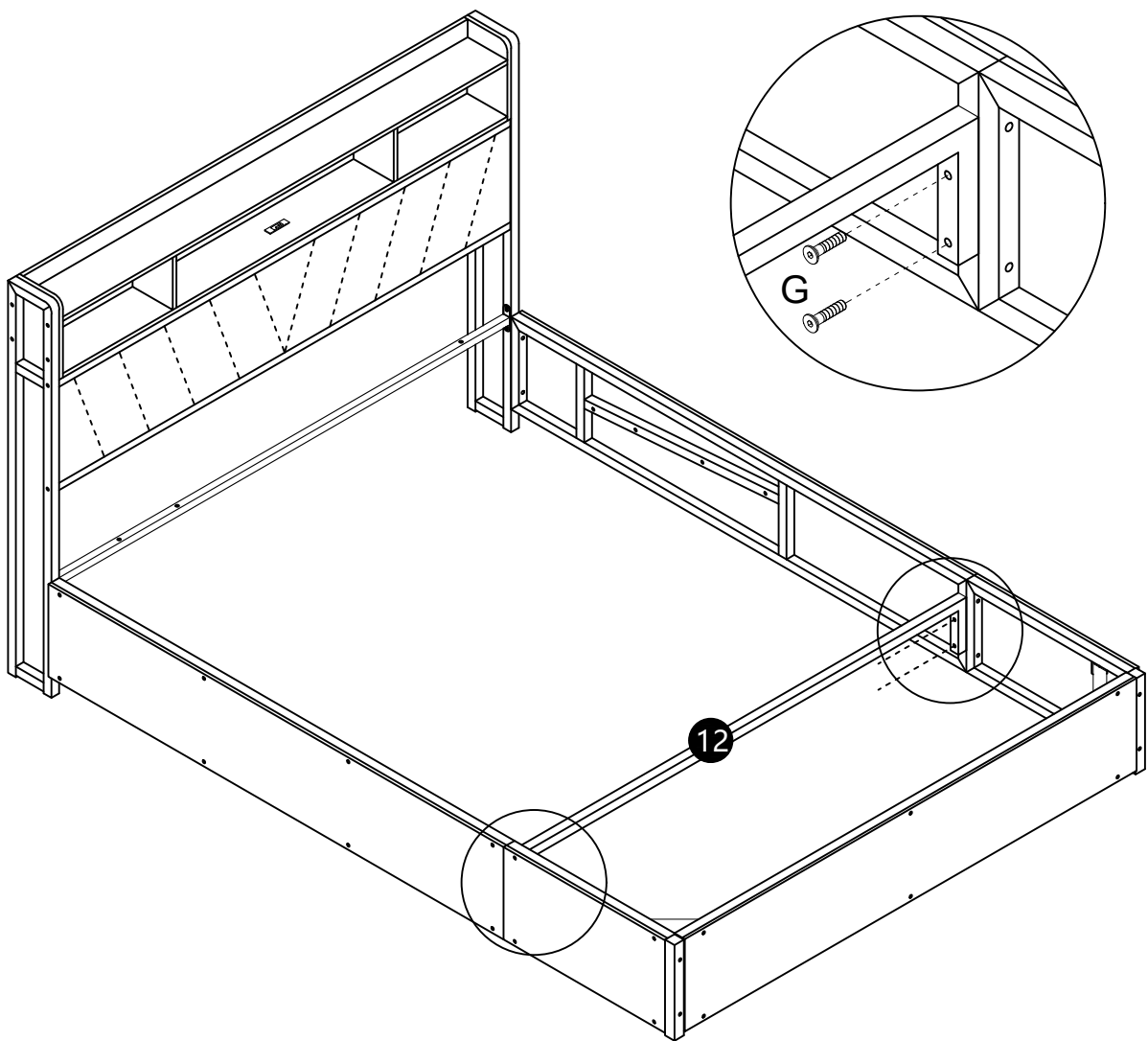

# Upholstered bed

19

E M8\*20

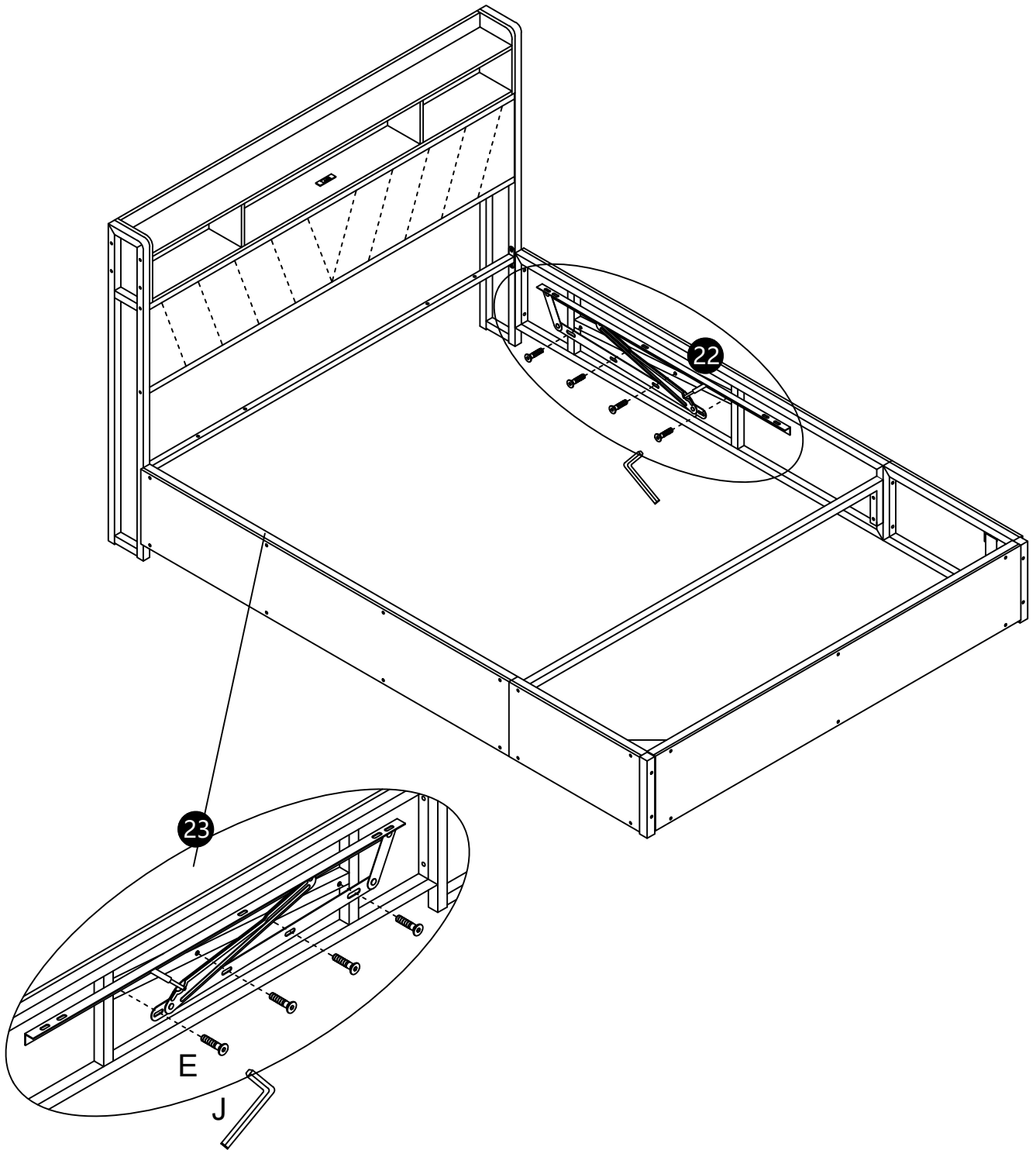

# Upholstered bed

20

D M8\*15  
 X4

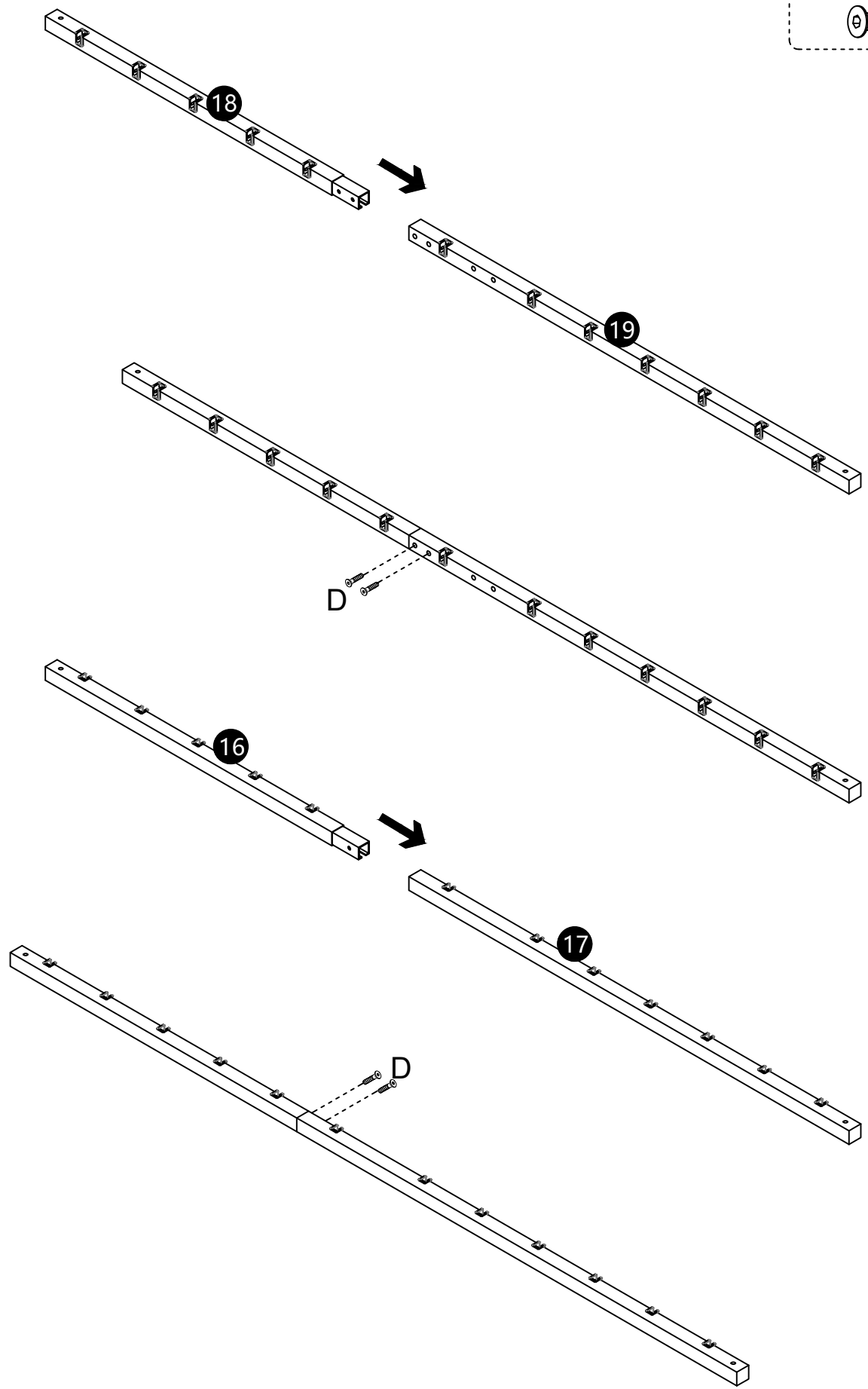

# Upholstered bed

21

D M8\*15

 X8

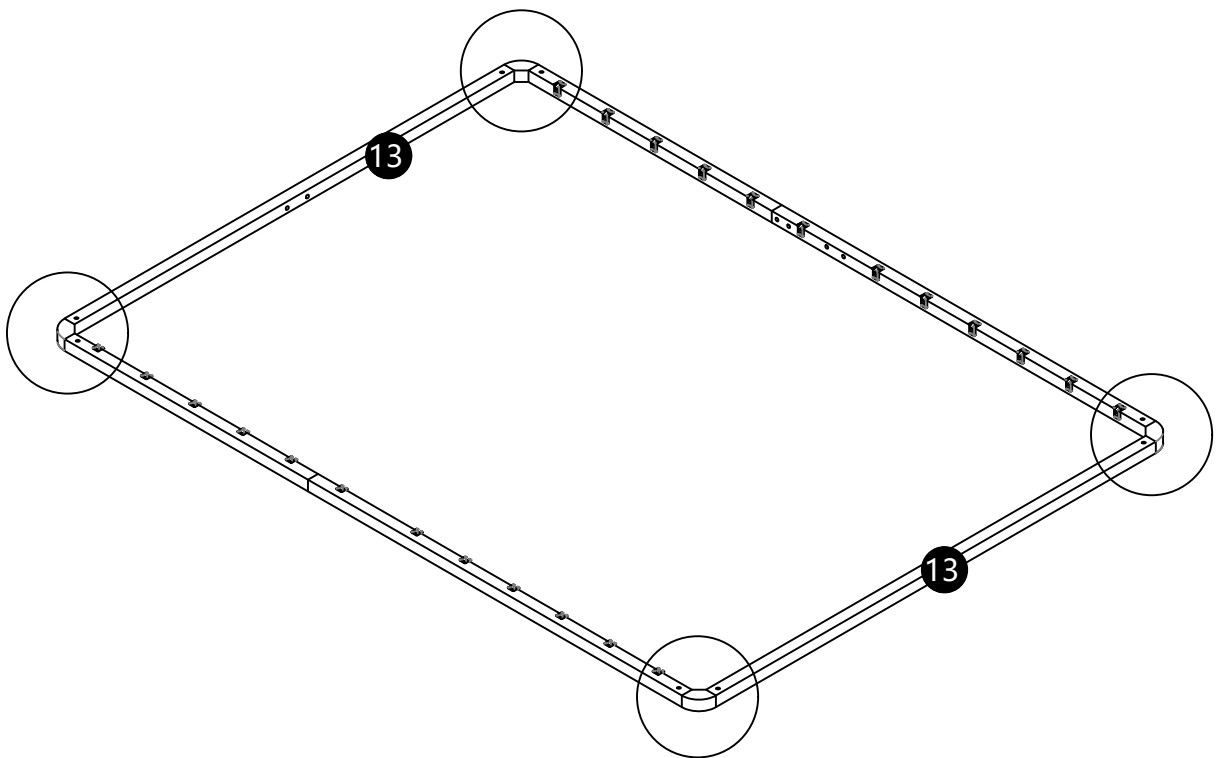
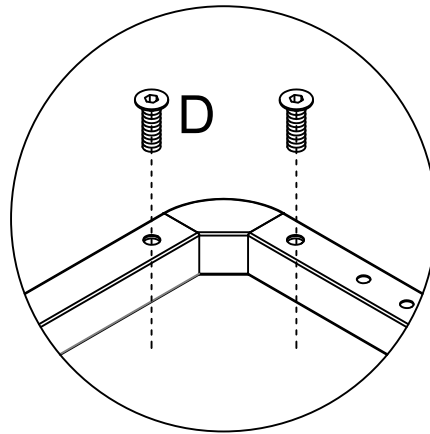
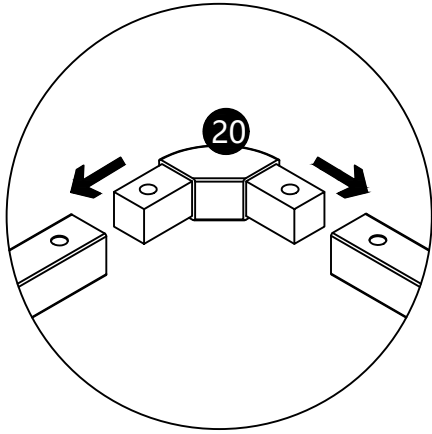

# Upholstered bed

22

E M8\*20

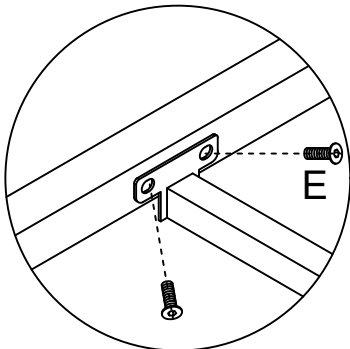
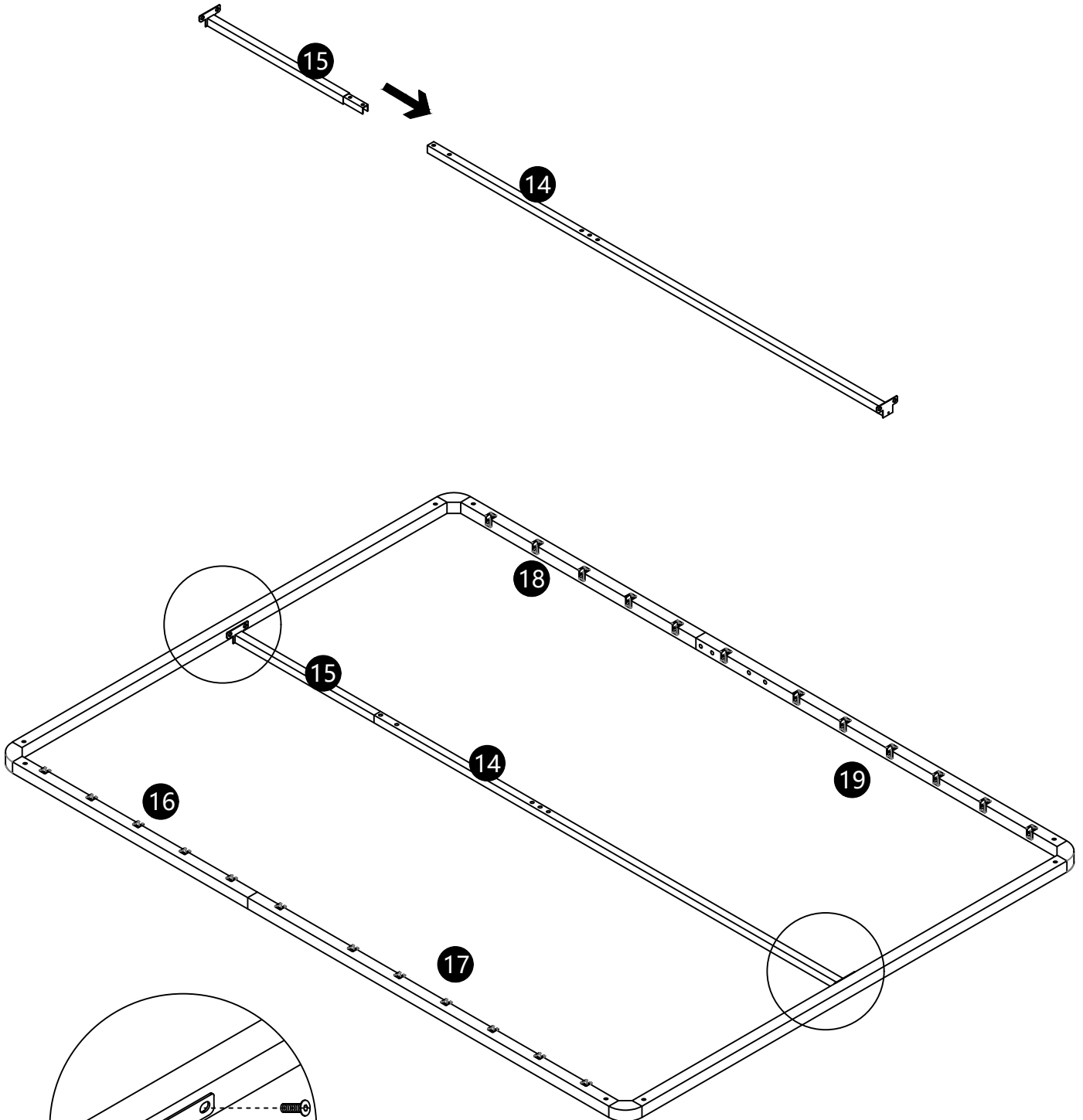

# Upholstered bed

23

F M8\*35  
 X4

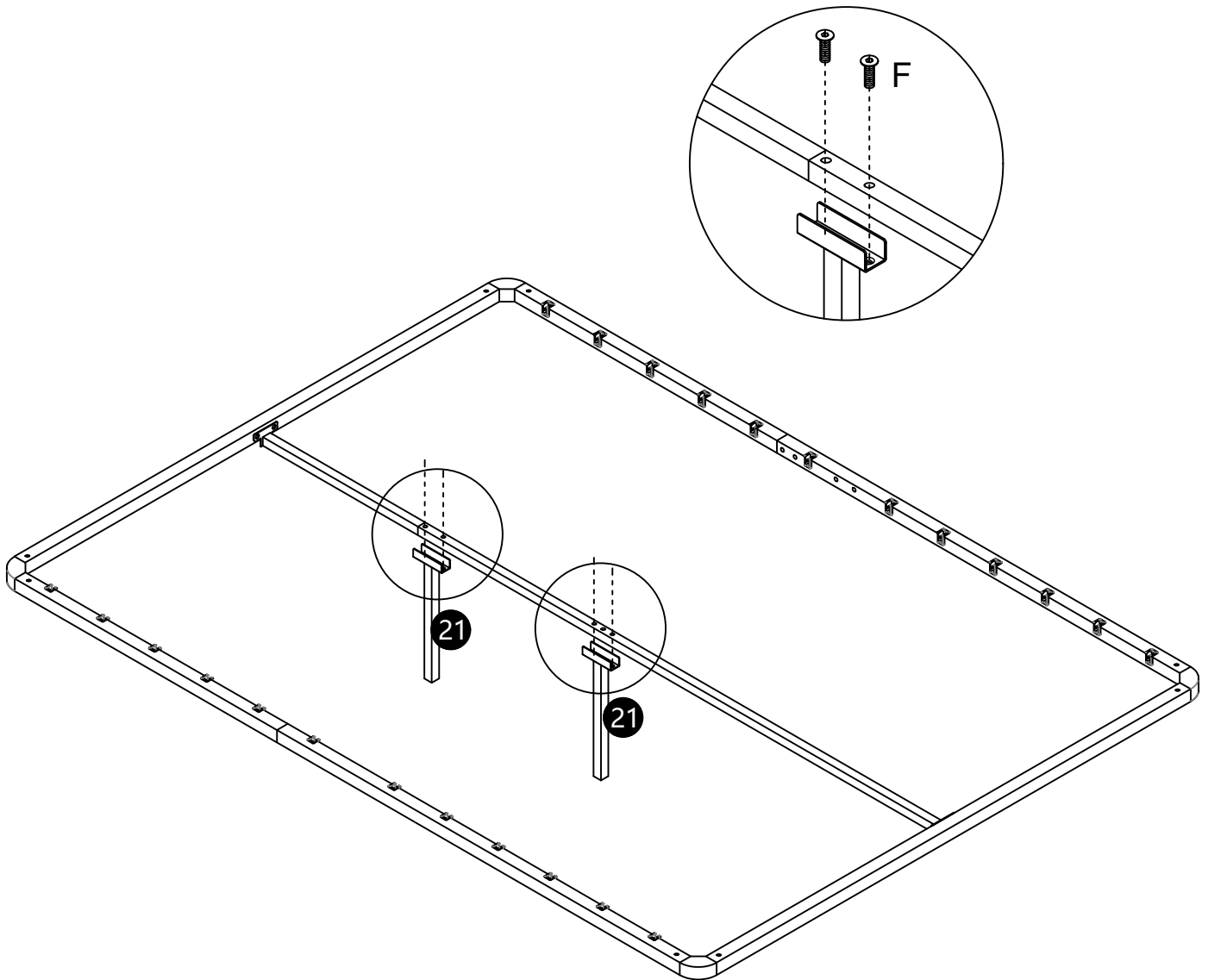

# Upholstered bed

24

E M8\*20



G M8\*45

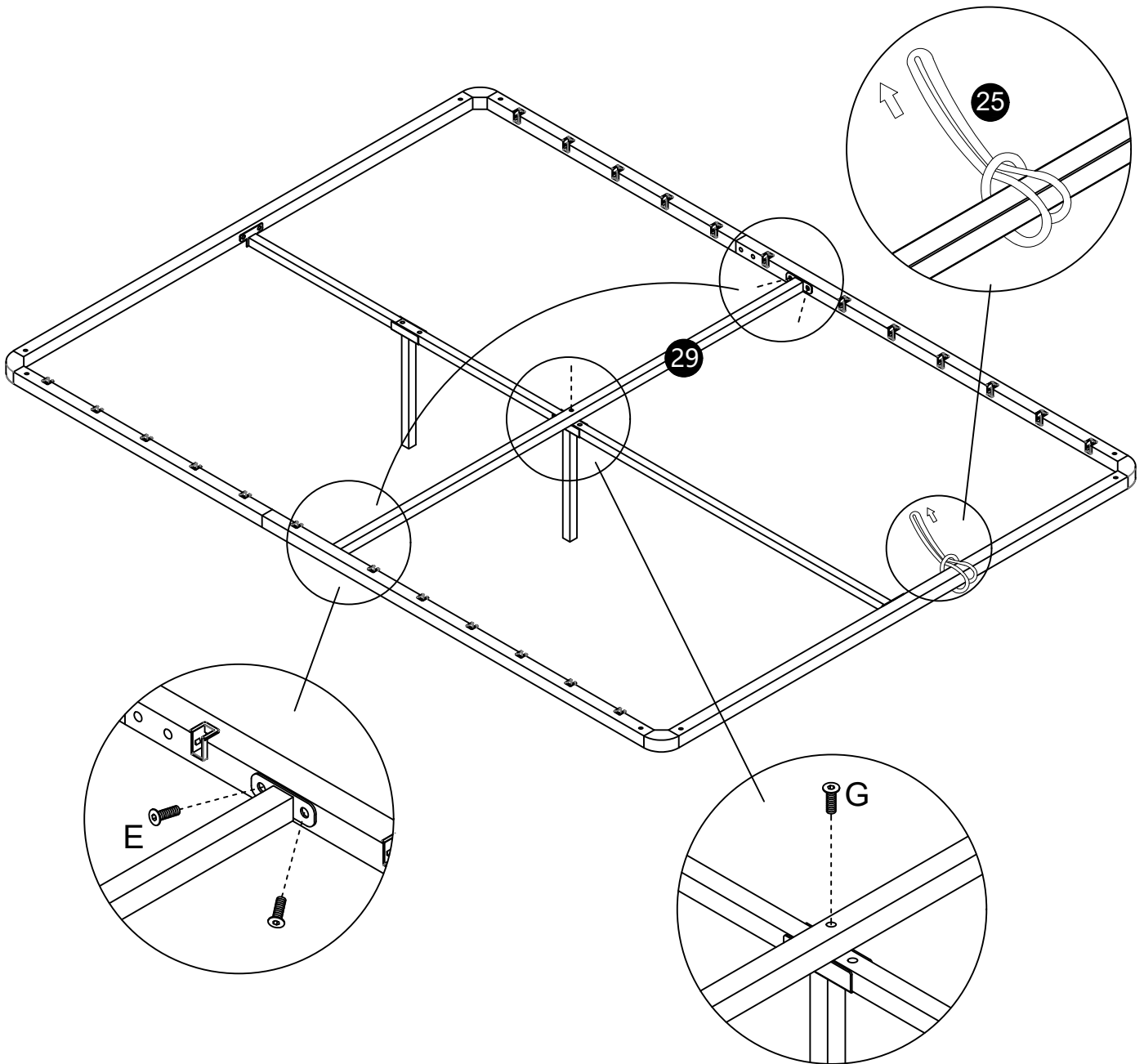

# Upholstered bed

25

E M8\*20

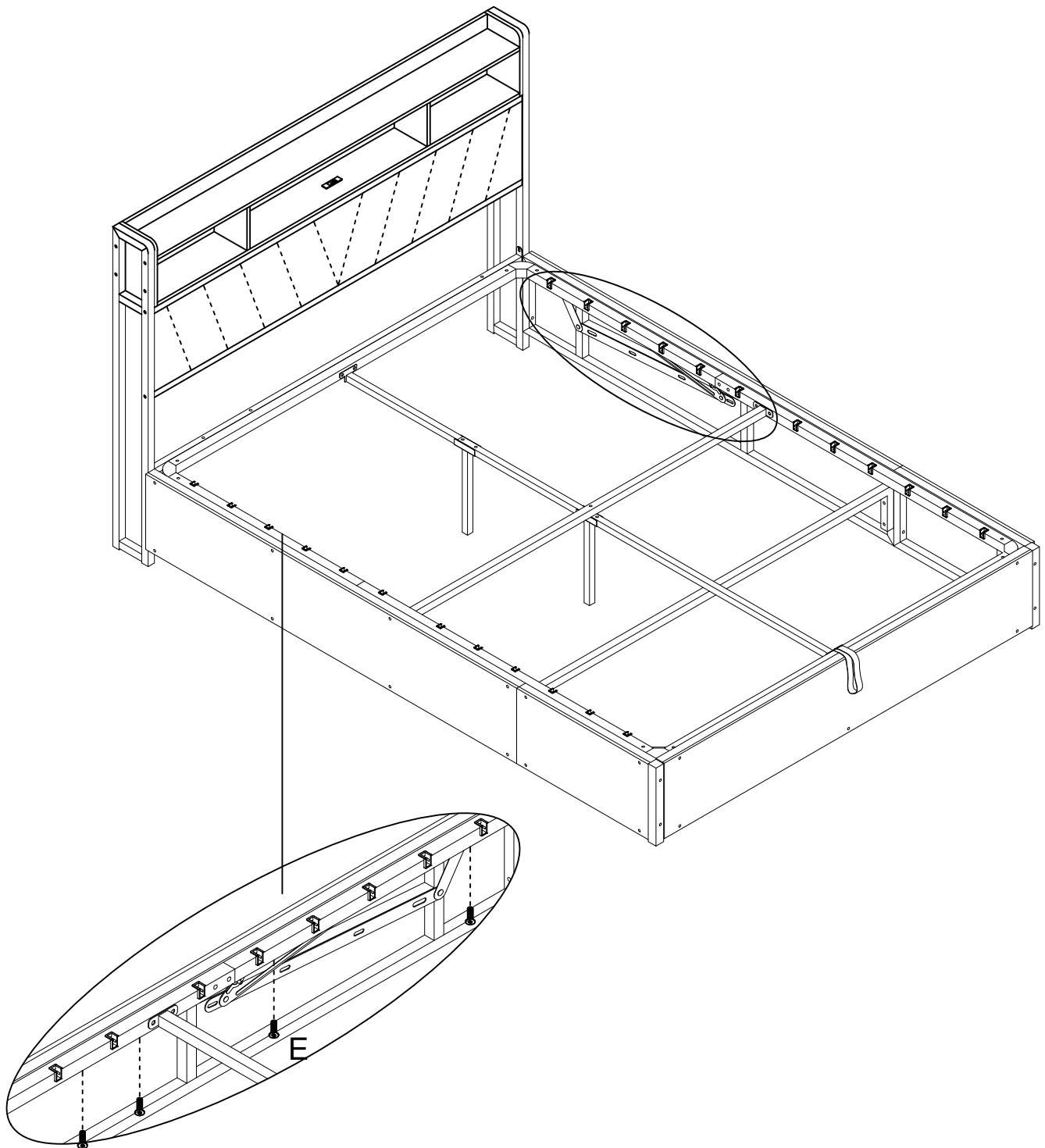

# Upholstered bed

26

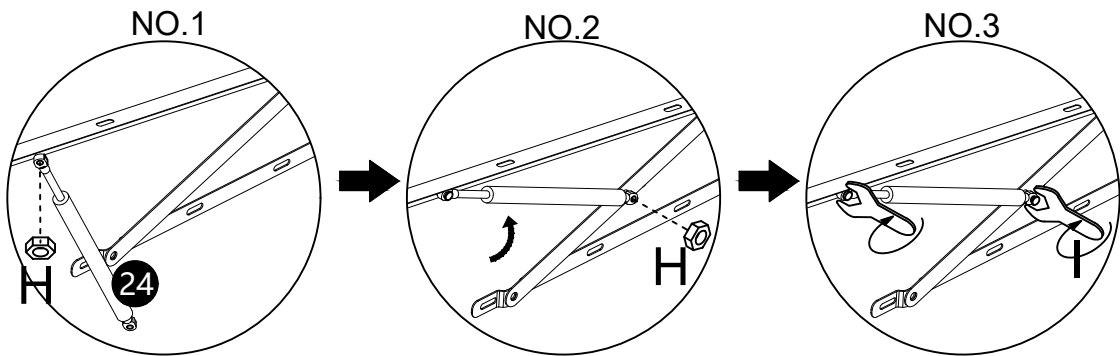
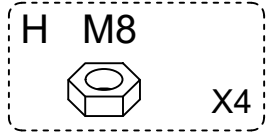

One person lifts the bed frame, while the other locks the nut

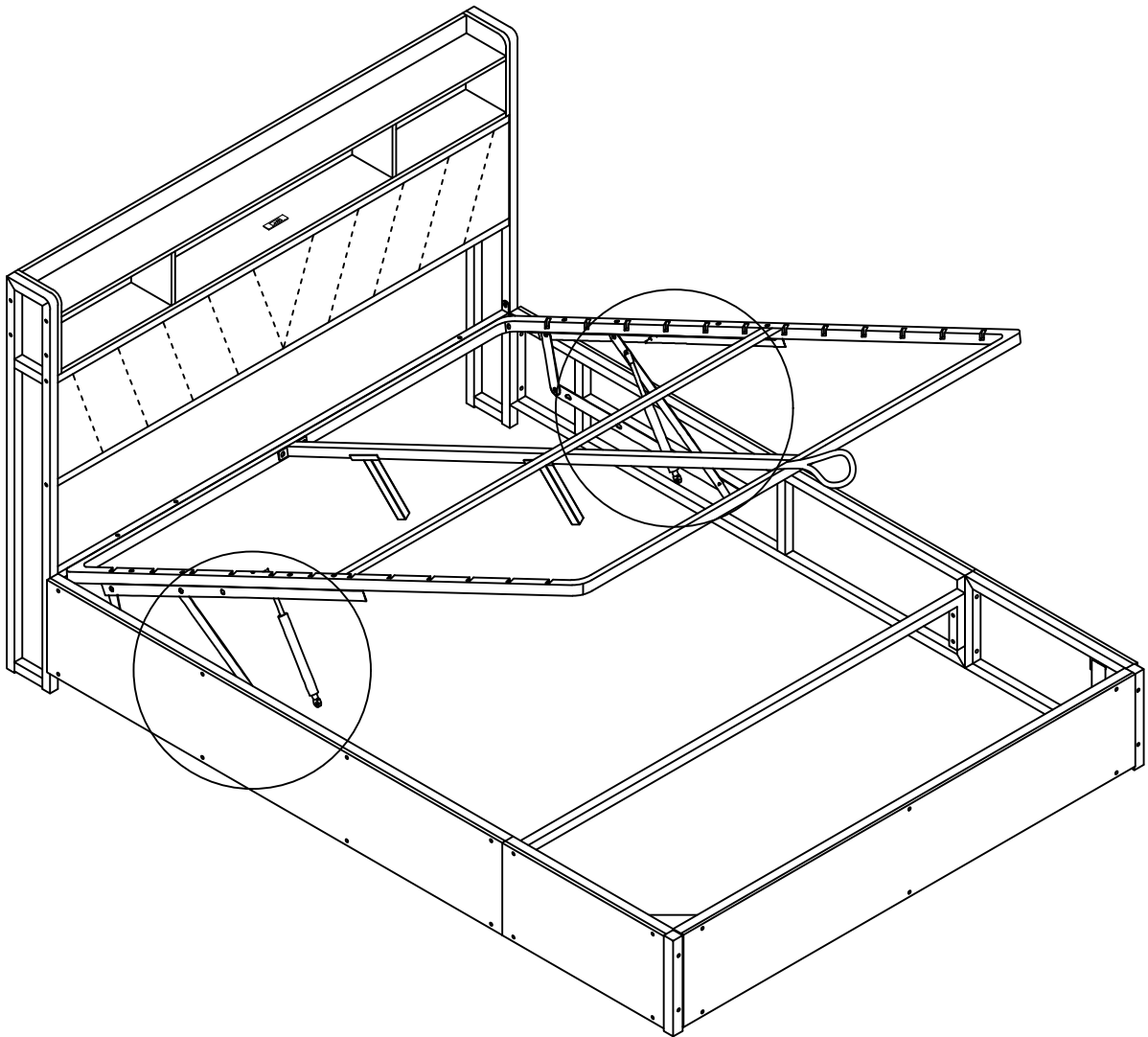

# Upholstered bed

27

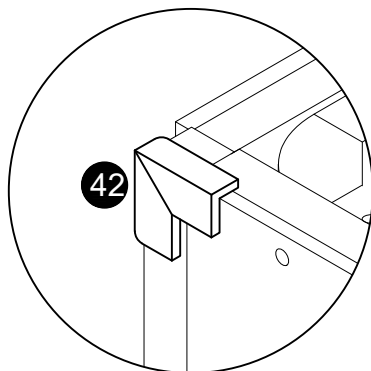
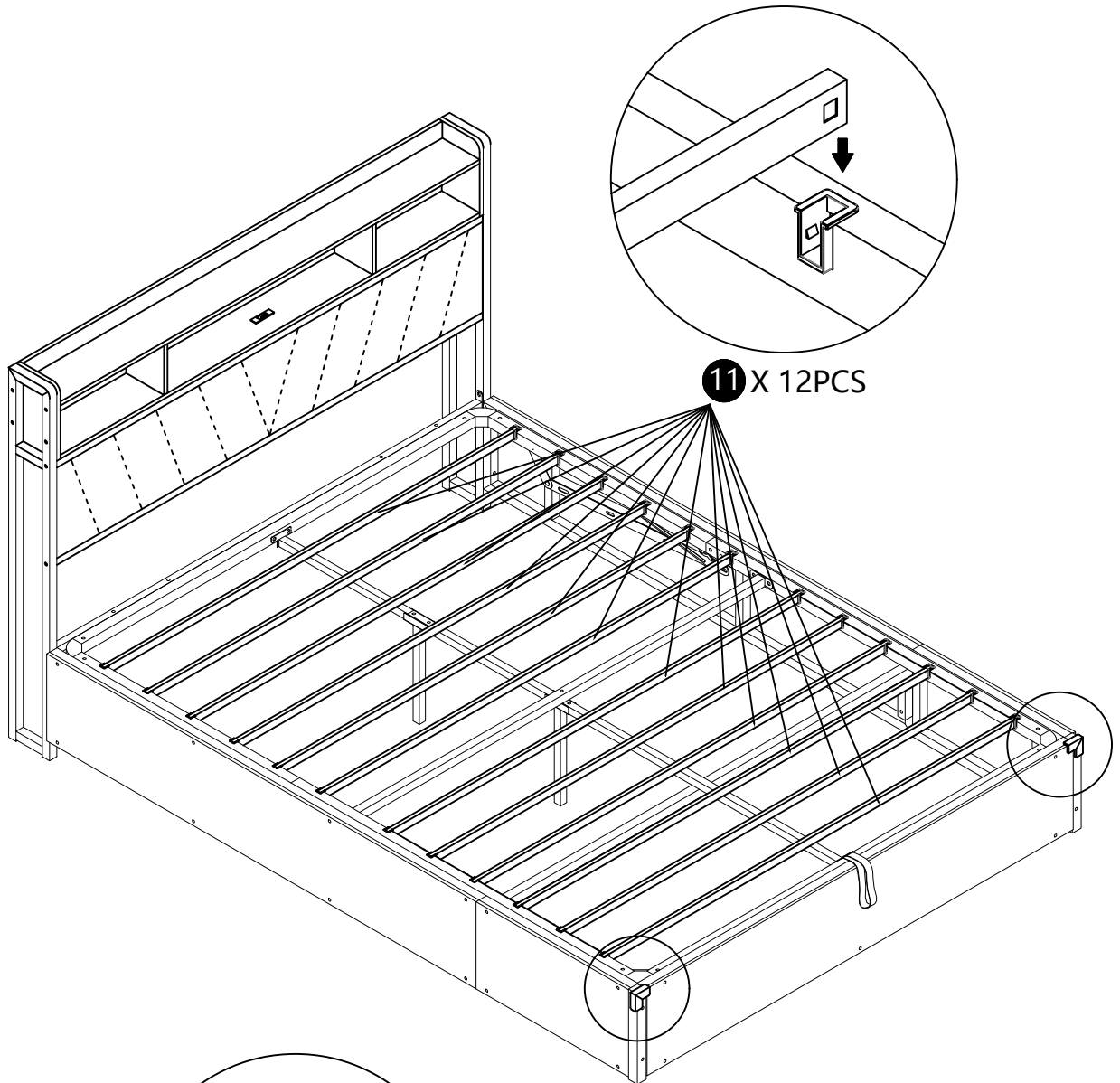

Then tear off the surface anti sticking sheet and stick the anti-collision cushion on it

# Upholstered bed

28

In order to better reflect the assembly process of LED light belt, this drawing adopts the exploded view of bed cabinet.

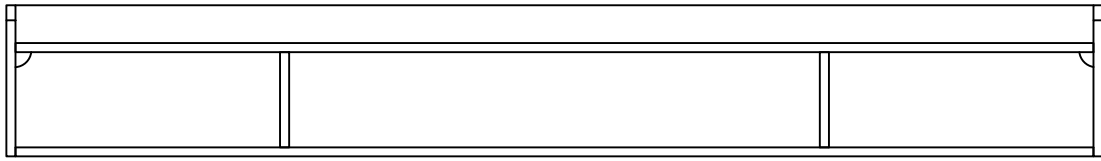

Please pass the light strip through the holes in sequence as shown in the diagram and exit from the holes in the rear panel.

Please note that the adhesive surface should be attached to the inner winding surface for optimal use.

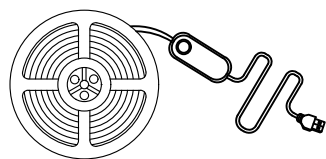
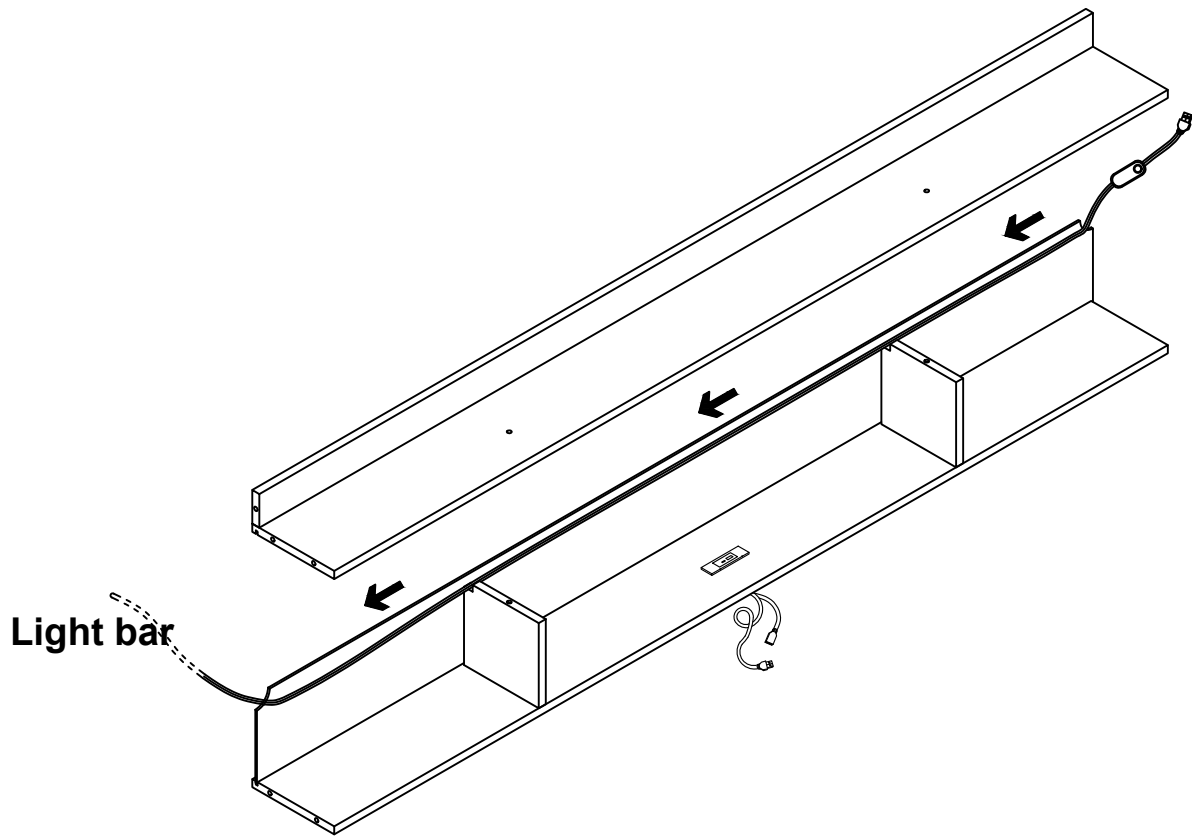

Light bar



Pull out  
and unfold

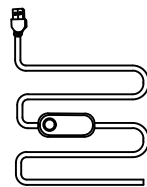

Light bar

The unfolded light strip has a light strip surface on one side and a magic veneer on the other side

Shenzhen ZKT Technology Co., Ltd.  
 1/F, No. 101, Building B, No. 6, Tangwei Community Industrial Avenue,  
 Fuhai Street, Bao'an District, Shenzhen, China



# Certificate of Compliance

Certificate Number: ZKT-2405094943C

- Certificate's Holder** : Shenzhen Pinchengxin Technology Co., Ltd  
 3rd Floor, 8th Building Yuanling Industrial Zone, No. 39  
 Yuanlingcun Road, Shiyan Street, Bao'an District,  
 Shenzhen
- Manufacturer** : Shenzhen Pinchengxin Technology Co., Ltd  
 3rd Floor, 8th Building Yuanling Industrial Zone, No. 39  
 Yuanlingcun Road, Shiyan Street, Bao'an District,  
 Shenzhen
- Trade Mark** : N/A
- Product** : 5050 RGB LED Strip Lights with Bluetooth App Controller  
 and 2.4G Remote
- Model(s)** : 5050 RGB LED Strip Lights
- Test Standard** : Art.3.1(a) Safety BS EN IEC 62368-1:2020+A11:2020  
 Art.3.1(a) Health BS EN IEC 62311:2020  
 BS EN 50665:2017  
 Art.3.1(b) EMC ETSI EN 301 489-1 V2.2.3 (2019-11)  
 ETSI EN 301 489-17 V3.2.4 (2020-09)  
 Art.3.2 Radio ETSI EN 300 328 V2.2.2 (2019-07)

This Attestation of Compliance is issued on a voluntary basis for electrical equipment below the voltage limits of Radio Equipment Directive (RED) SI 2017 No.1206. The essential requirements are fulfilled accordingly based on the technical specifications applicable at the time of issuance.



This Certificate of Conformity is based on single evaluation of the submitted sample(s) of the above mentioned product. It does not imply an assessment of the whole product and relevant Directives to be observed.

# Attestation of Compliance



Attestation No. : LCSA08094161E  
Approval Holder : Shenzhen Pinchengxin Technology Co., Ltd  
Address : 3rd floor, 8 building Yuanling industrial zon, No. 39 Yuanlingcun road, Shiyan street, Bao'an district, Shenzhen  
Manufacturer : Shenzhen Pinchengxin Technology Co., Ltd  
Address : 3rd floor, 8 building Yuanling industrial zon, No. 39 Yuanlingcun road, Shiyan street, Bao'an district, Shenzhen  
Brand Name : N/A  
Product : 5050 RGB LED Strip Lights with Bluetooth App Controller  
Type/Model Name : 5050 RGB  
H/S Version : HW: 1.0  
SW: 1.0

Attestation of the technical design of the radio equipment according to the following essential requirements set out in article 3 of the RED 2014/53/EU:

Article 3.1a): Health and Safety	Conform
Article 3.1b): Electromagnetic Compatibility	Conform
Article 3.2: Effective Use of the Radio Spectrum	Conform
CE-marking	

Marking Example (Class 1)



This attestation is issued in accordance with the Directive 2014/53/EU of the European Parliament and of the Council of 16 April 2014 on the harmonisation of the laws of the Member States relating to the making available on the market of radio equipment.

September 18, 2024

-----  
Date of issue



-----  
Manager

Shenzhen LCS Compliance Testing Laboratory Ltd.  
Room 101, 201, Building A and Room 301, Building C, Juji Industrial Park, Yabianxueziwei, Shajing Street,  
Bao'an District, Shenzhen, Guangdong, China  
Tel: (86)0755-82591330 Fax: (86)0755-82591332  
Http://www.lcs-cert.com Email: webmaster@lcs-cert.com



# Shenzhen Pinchengxin Technology Co., Ltd

Federal Communications Commission  
Authorization and Evaluation Division  
Equipment Authorization Branch  
7435 Oakland Mills Road  
Columbia, MD 21046

9/2/2024

## U.S. Agent Designation

Shenzhen Pinchengxin Technology Co., Ltd acknowledges their consent for the following contact located in the United States to act as their agent for service of process for the equipment for which authorization is sought (FCC ID: 2BKKLPCX-977):

Name and company of U.S. agent: FCC US Agent, LLC  
Physical U.S. address of agent: 3722 Illinois Avenue, Saint Charles, IL, 60174, USA  
FRN of U.S. agent: 0033402884  
Email address of U.S. agent: Support@FCCUSAgent.com

FCC US Agent, LLC acknowledges their obligation to accept service of process on behalf of Shenzhen Pinchengxin Technology Co., Ltd.

Shenzhen Pinchengxin Technology Co., Ltd with the FRN 0035866896 accepts its obligation to maintain an agent for service of process in the United States for no less than one year after either the grantee has permanently terminated all marketing and importation of the applicable equipment within the U.S., or the conclusion of any Commission-related administrative or judicial proceeding involving the equipment, whichever is later.

By signing this form, we confirm the above and that we are aware of the application requirements listed under § 2.911(d)(7).

The information provided in this letter is based on the referenced rule parts of Title 47 of the CFR as well as KDB 986446 D01.

An expiration date for this letter does not exist. In case the U.S. agent changes, the grantee is obligated to notify the FCC within 30 days via the granting TCB.

Sincerely,

**CHENG ZHANG**

Signature  
CHENG ZHANG  
Manager  
Shenzhen Pinchengxin Technology Co., Ltd

Tim  
*Tim Payne* **Payne**  
Digitally signed by Tim  
Payne  
DN: cn=Tim Payne, o=FCC  
US Agent, LLC, ou=FCC US  
Agent, LLC,  
email=Support@fccagent.com,  
c=US,  
Date: 2024.09.02 20:14:06  
-0500

Signature  
Tim Payne  
Manager  
FCC US Agent, LLC