

Bed Frame

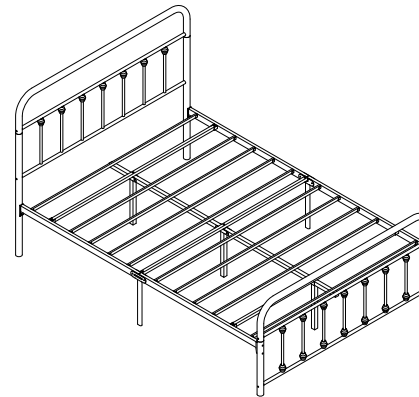

Bed Frame

CAUTION!

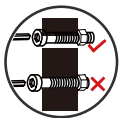

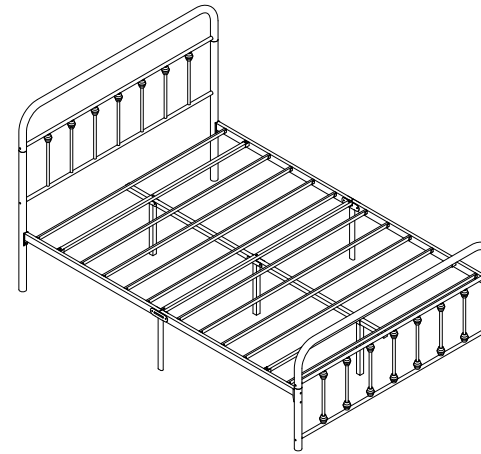

Bettrahmen

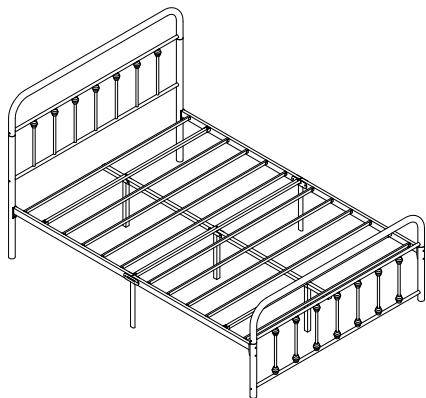

Bettrahmen

ACHTUNG!

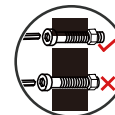

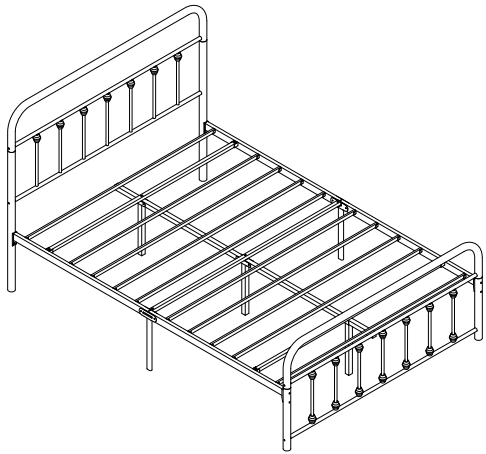

Cadre du lit

ATTENTION !

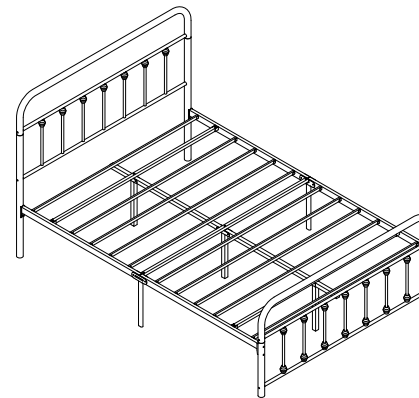
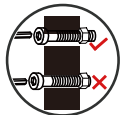

Cadre du lit

● #Number System

Follow the marked steps for the easiest assembling process
step 1 step 2 step 3 step 4...

★ #Zahlensystem

Folgen Sie den markierten Schritten für den Zusammenbau
auf einfachste Weise

Schritt 1 Schritt 2 Schritt 3 Schritt 4 ...

▲ Système de numération

Suivez les étapes indiquées pour faciliter le processus de montage :
étape 1, étape 2, étape 3, étape 4, etc.

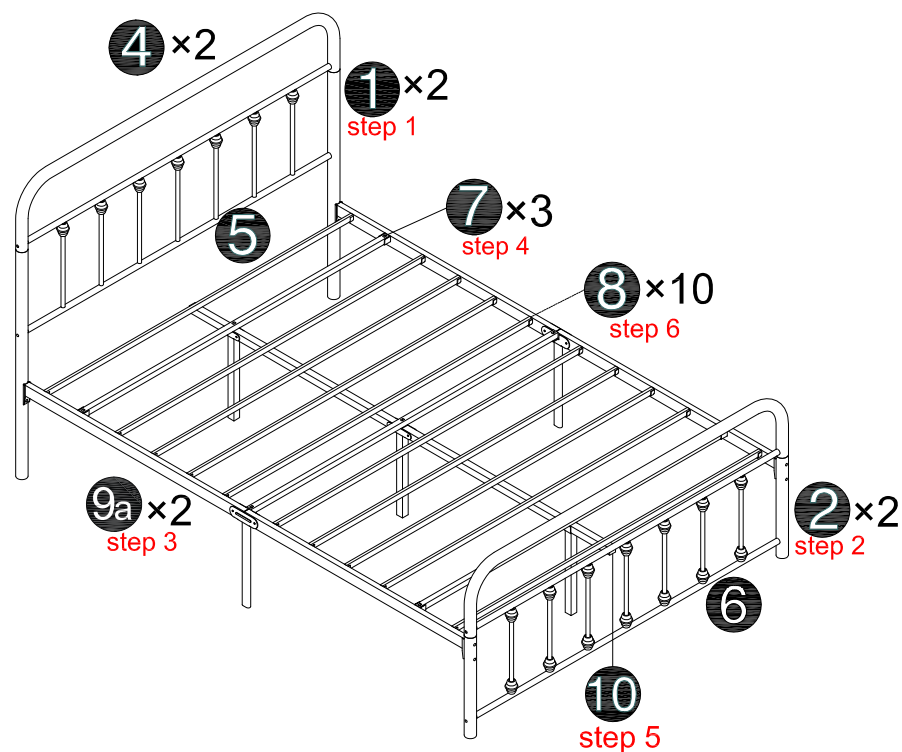

Step 7

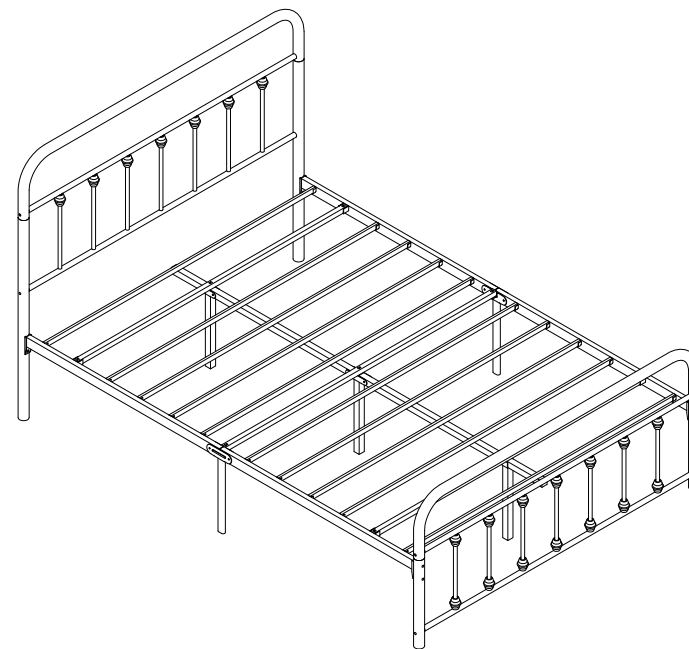

- Note: Now remember to double check all screws are properly fastened
- ★ Hinweis: Vergessen Sie jetzt nicht, zu überprüfen, ob alle Schrauben richtig angezogen sind.
- ▲ Remarque : N'oubliez pas de vérifier que toutes les vis sont bien serrées.

Step 6

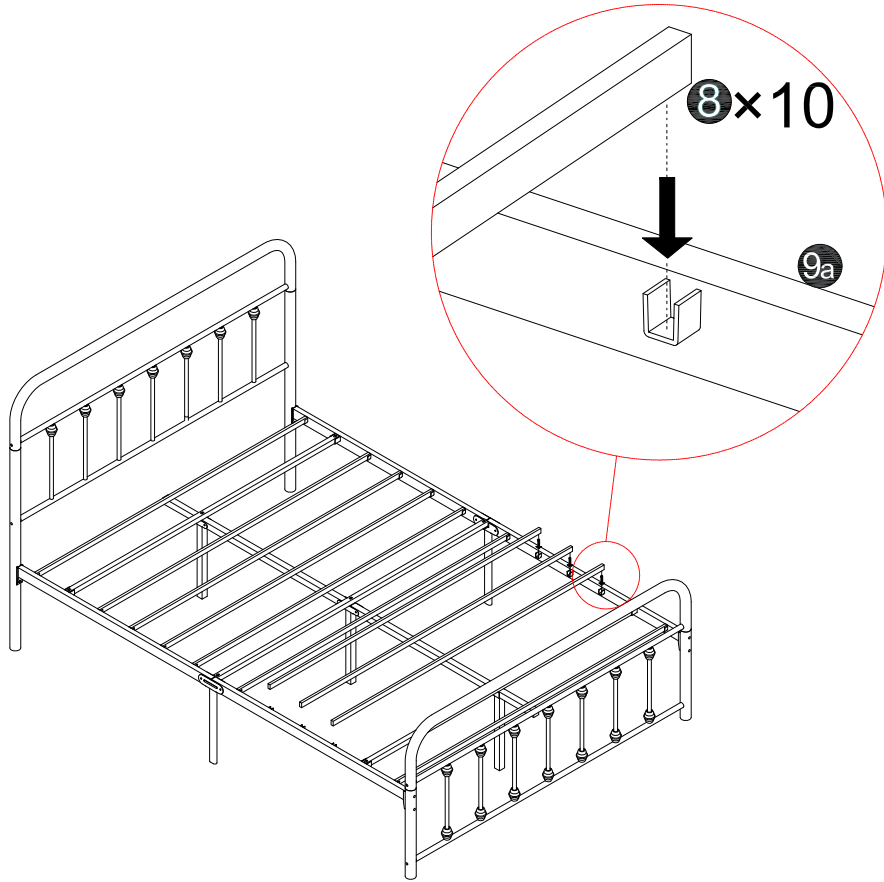





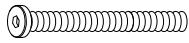

Components / Bauteile / Composants

1		2pcs	2		2pcs
4		2pcs	5		1pc
6		1pc	7		3pcs
8		10pcs	9a		2pcs
10		1pc			

- With Screw Holes
- ★ Mit Schraubenlöchern
- ▲ Avec trous de vis

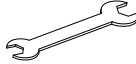
- Without Screw Holes
- ★ Ohne Schraubenlöcher
- ▲ Sans trous de vis

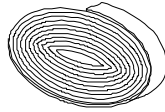
A	 M8x55mm	8pcs	B	 M6x55mm	11pcs
C	 M6x28mm	6pcs	D	 M8	4pcs
E	 φ8.5mm	16pcs	F	 M13/M10	1pc
G	 5mm	1pc			
N		1pc			

Step 5

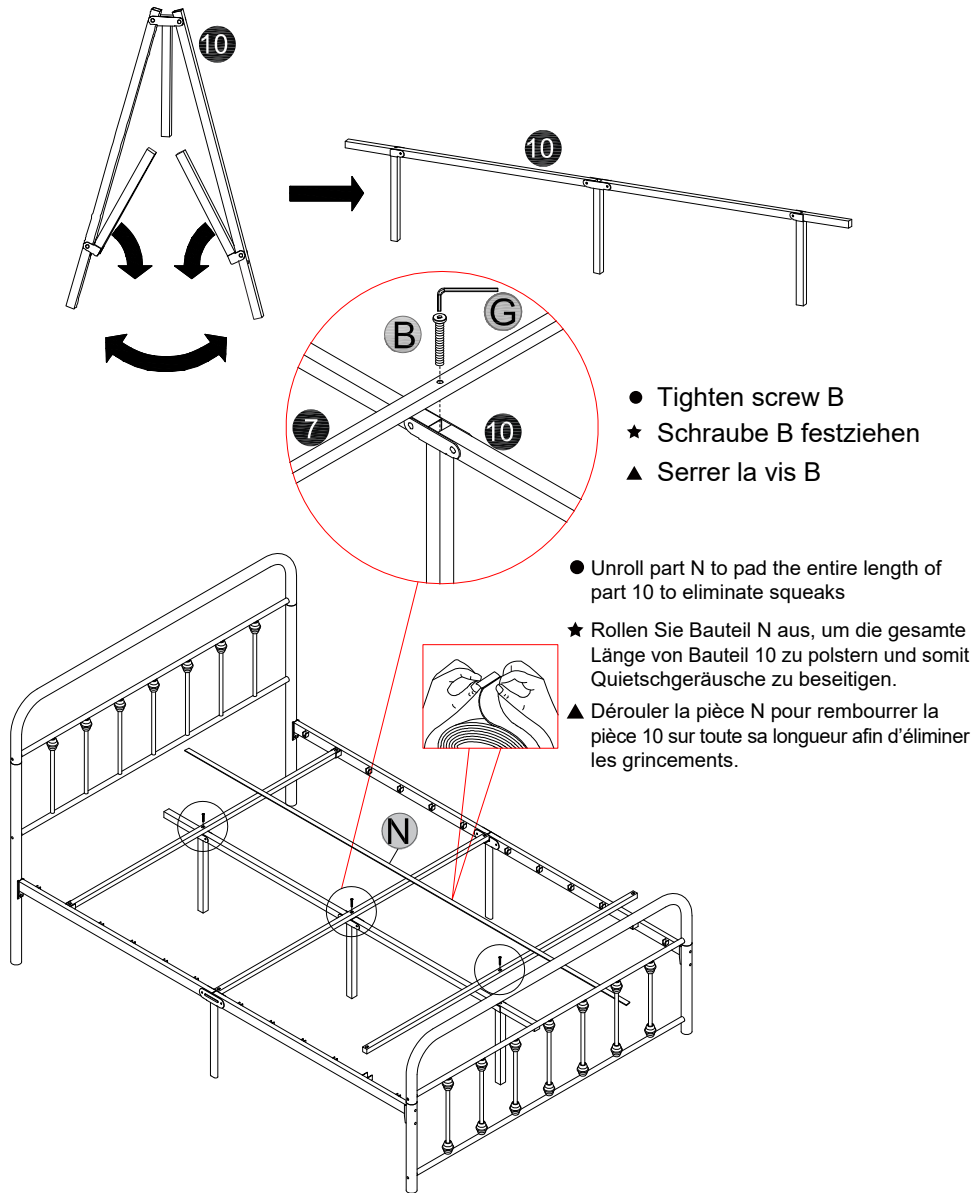
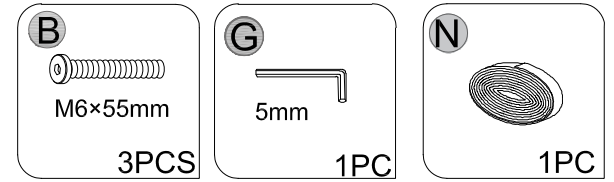

Step 4

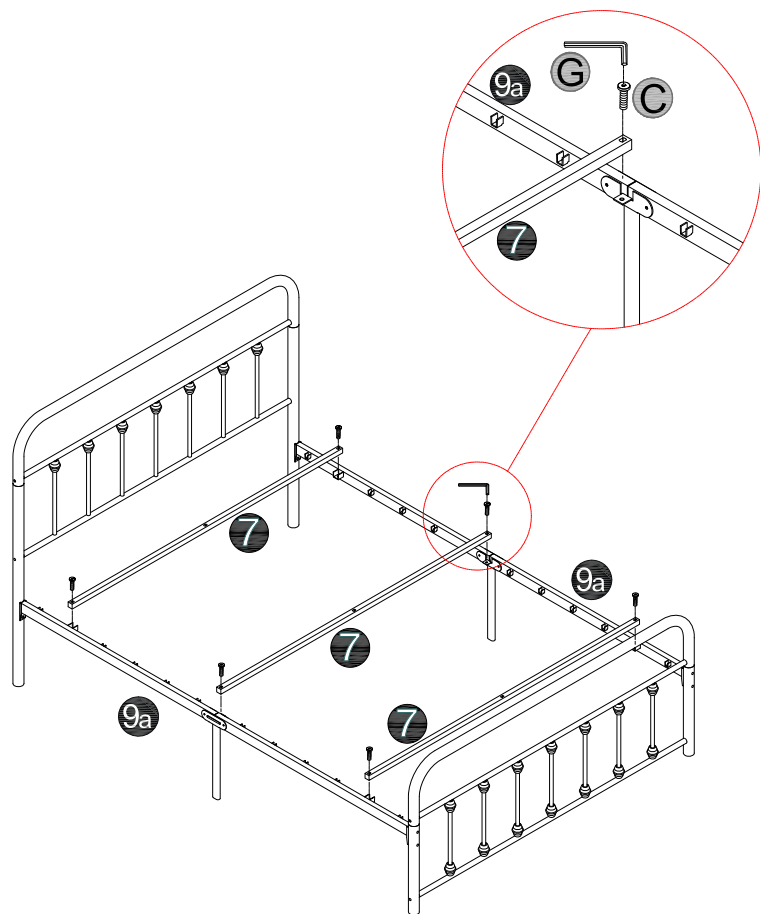
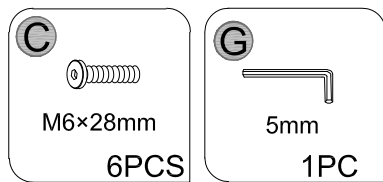

Step 1

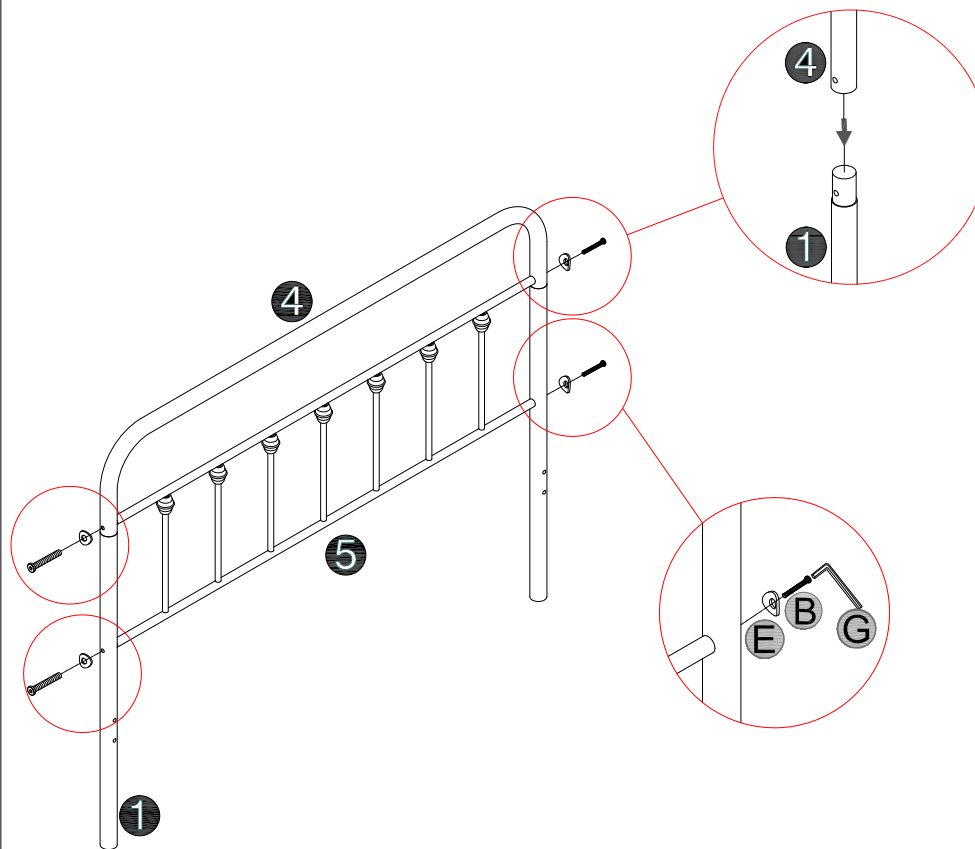
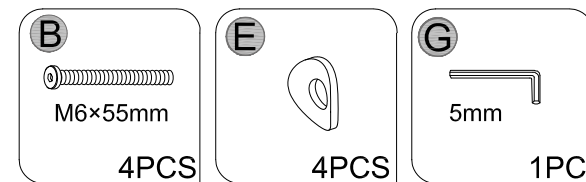

Step 2

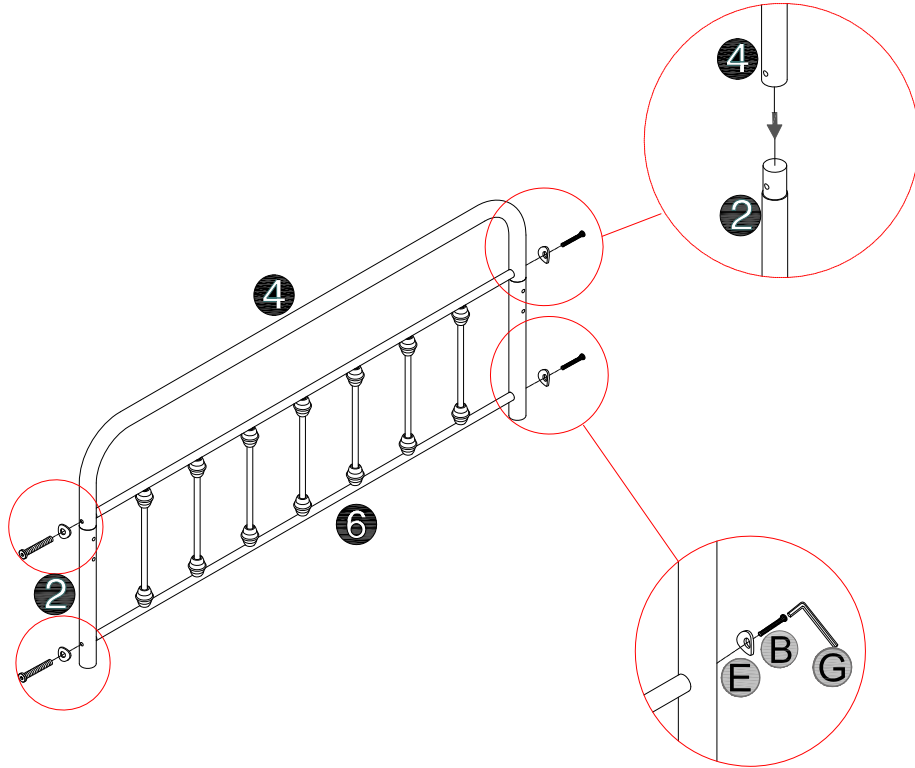
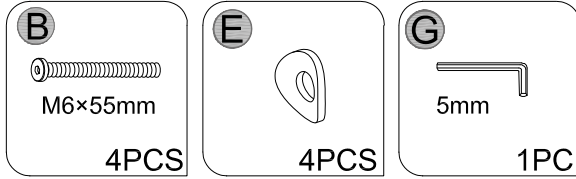

Step 3

