

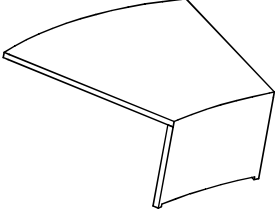

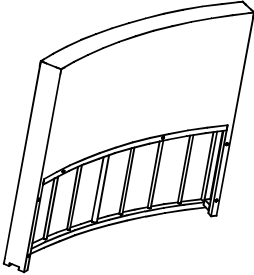
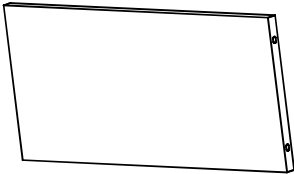
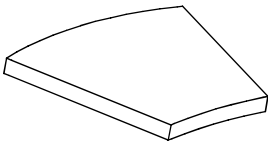

Assembly Instructions

Please read this before you proceed

NUMBER	COMPONENT	QUANTITY
A	 Seat plate	2pcs
B	 Back	2pcs
C	 Side panel	4pcs
K	 Sofa cushion	2pcs
L	 Sofa backrest cushion	2pcs

Assembly Instructions

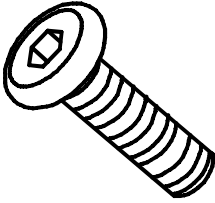
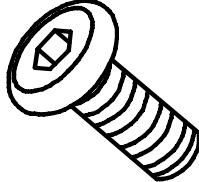
Please read this before you proceed

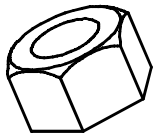
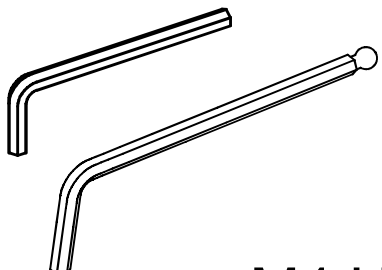
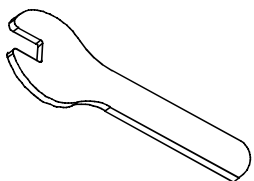
NUMBER	COMPONENT	QUANTITY
M	 Bolt M6x55mm	12pcs
N	 Bolt M6x35mm	8pcs
O	 M6 shim	32pcs
P	 M6 nut	12pcs
Q	 M4 Hex wrench	2pcs
R	 Spanner	1pc

Assembly Instructions

Please read this before you proceed

①

A x 1
C x 1
O x 2
N x 2
Q x 1

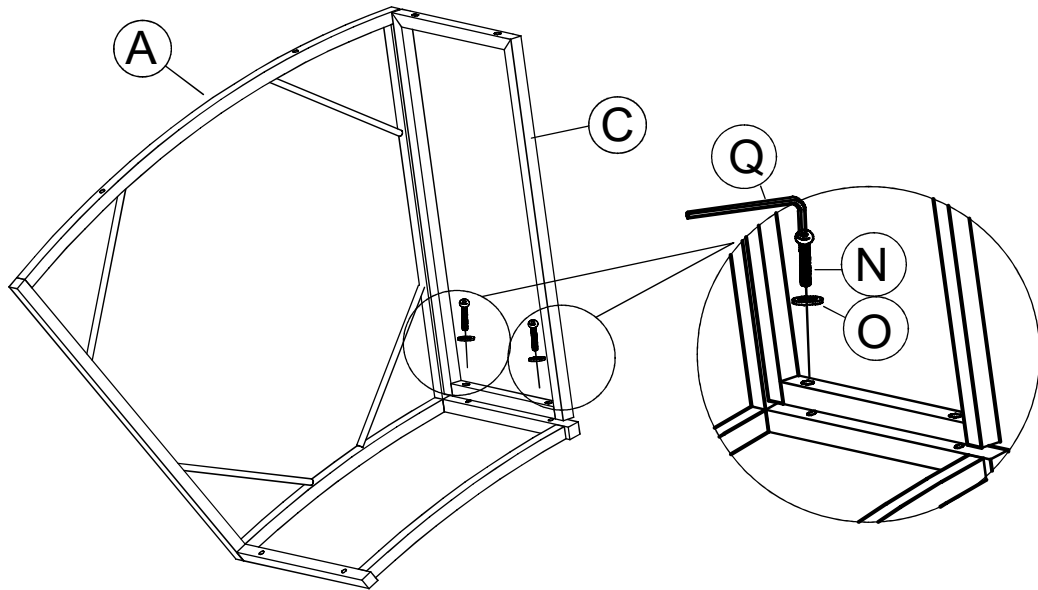

Use the Allen key (Q), bolt (N) and flat washer (O) to connect the part (C) and part (A).

This process requires two operations.

Note: only tighten 80%

②

C x 1
O x 2
N x 2
Q x 1

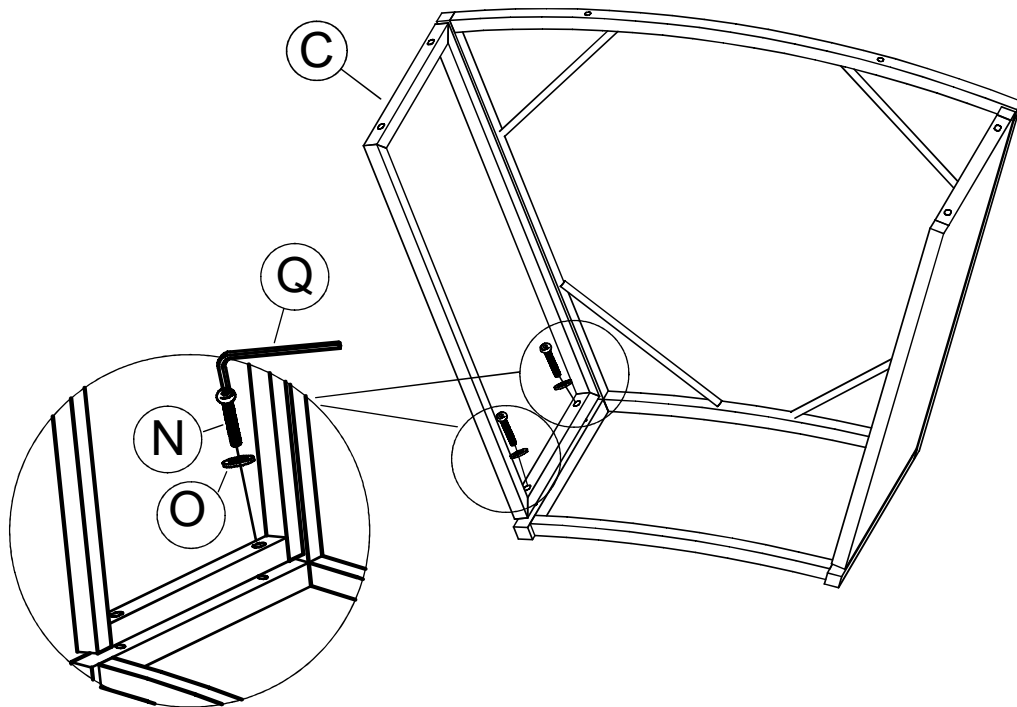

Use the Allen key (Q), bolt (N) and flat washer (O) to connect the part (C).

This process requires two operations.

Note: only tighten 80%

Assembly Instructions

Please read this before you proceed

③

B x 1
O x 12
M x 6
Q x 1
P x 6
R x 1

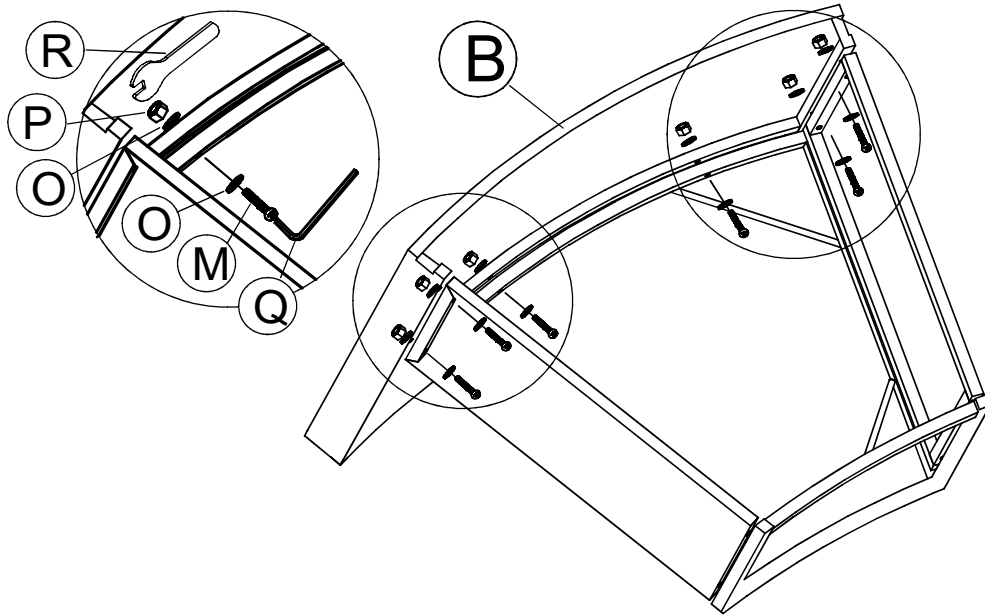

Use the Allen key (Q), bolt (N) and flat washer (O) to connect the part (B).

This process requires two operations.

Note: only tighten 80%

④

L x 1
K x 1

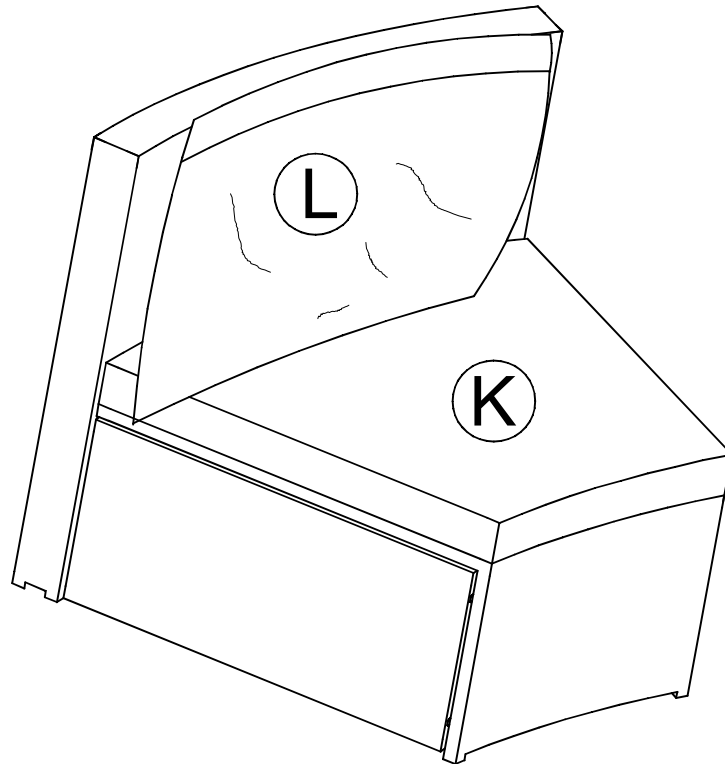

Use part (K), part (L).

Assembly Instructions

Please read this before you proceed

5

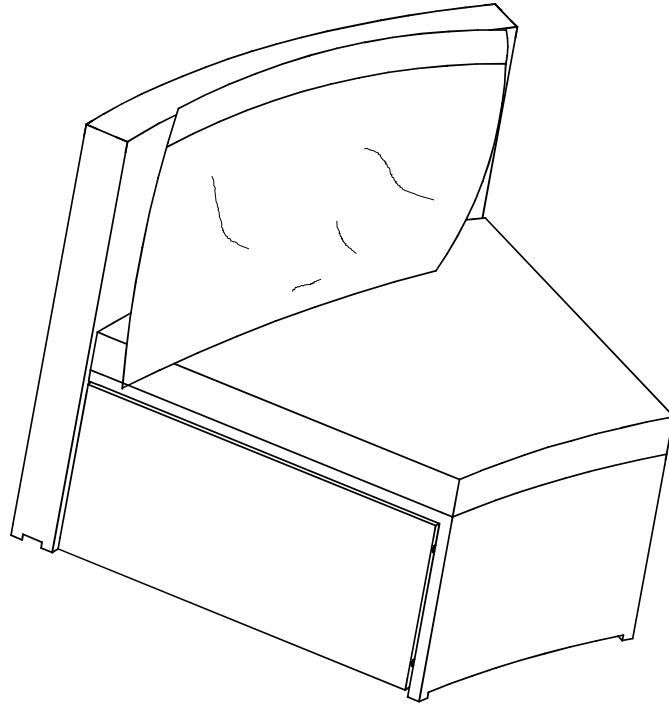

6

