

# **INSTALLATION**

*Product Manual*

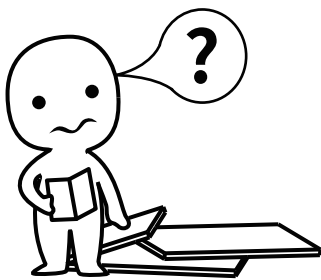

### **IMPORTANT INFORMATION!**

please read the entire manual before starting to assemble and/or using this product, follow the manual thoroughly and keep it for further reference.

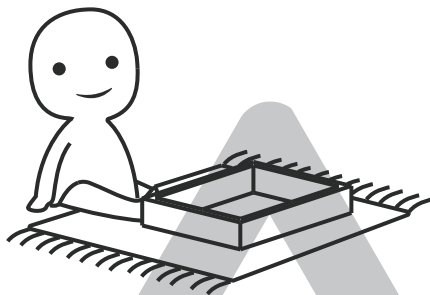
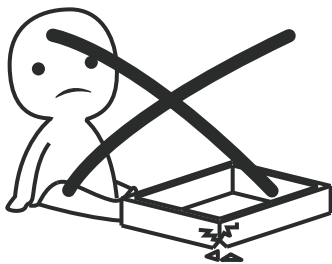

### **AVOID SCRATCHES!**

In order to avoid scratching this furniture should be assembled on a soft layer-could be a rug.

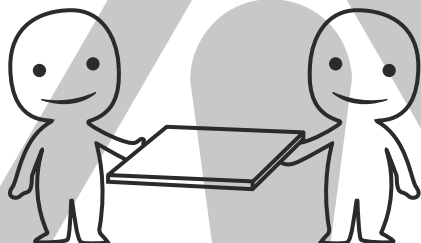

### **IMPROVE EFFICIENCY !**

Try to find a partner to install with you, which can speed up the installation efficiency and shorten the time.

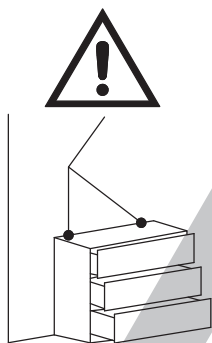

### **ANTI-TOPPLE WARNING !**

Overturnd furniture can cause serious or fatal crush injuries. To prevent tipping over, be sure to use the wall attachment, if not included with this product. Please purchase the wall attachment that fit your wall. If unsure, seek professional advice. Please read and follow each step of the instructions carefully.

### **IMPORTANT !**

It is important that any product which is assembled using any kind of screw is re-tightened 2 weeks after assembly, and once every 3 months - in order to assure stability through-out the lifespan of the product.

For regular maintenance and cleaning of the product, for the frame, please use a rag dipped in neutral detergent to fully wipe it, and then dry it with a clean rag. For glass materials, wipe with a rag dampened with water glass cleaner, and then dry with a dry rag.

Do not use an electric screwdriver, and do not use too much force when installing, because the board is easy to break.

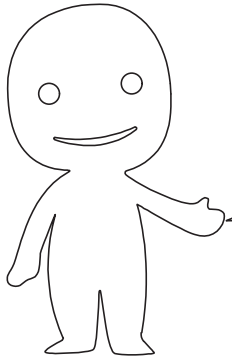

Please prepare the following tools

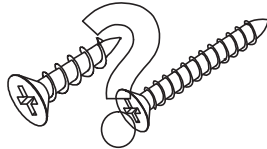
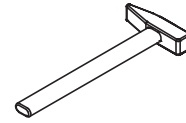
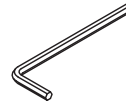
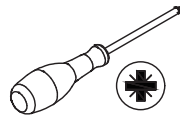

When installing, please carefully confirm whether each screw corresponds to the manual, accessories with similar shapes can be distinguished by size

<p>A x 73</p>  <p>CRA0635A</p>	<p>B x 73</p>  <p>CRB1595A</p>	<p>C x 16</p>  <p>CRF0630A</p>	<p>D x 22</p>  <p>CRC0540A</p>	<p>E x 4</p>  <p>DGA861A</p>
<p>F x 36</p>  <p>CRD3514A</p>	<p>G x 3</p>  <p>#3508 12"</p>	<p>H x 30</p>  <p>CRD3512A</p>	<p>I x 10</p>  <p>CRF0650A</p>	<p>J x 16</p>  <p>CRE0316A</p>
<p>K x 8</p> 	<p>L x 6</p>  <p>∅ 6 x 8 mm</p>	<p>M x 8</p>  <p>∅ 6 x 40 mm</p>	<p>N x 4</p>  <p>∅ 6 x 8 mm</p>	<p>O x 4</p> 
<p>P x 4</p> 	<p>Q x 24</p>  <p>∅ 6 x 12 mm</p>	<p>R x 4</p>  <p>∅ 6 x 20 mm</p>	<p>S x 2</p>  <p>∅ 4 x 45 mm</p>	<p>④④ x 1</p> 
<p>④⑤ x 1</p>  <p>#4</p>	<p>④⑥ x 8</p> 	<p>U x 4</p> 	<p>V x 4</p>  <p>CRG0612A</p>	<p>W x 1</p> 

X x 12



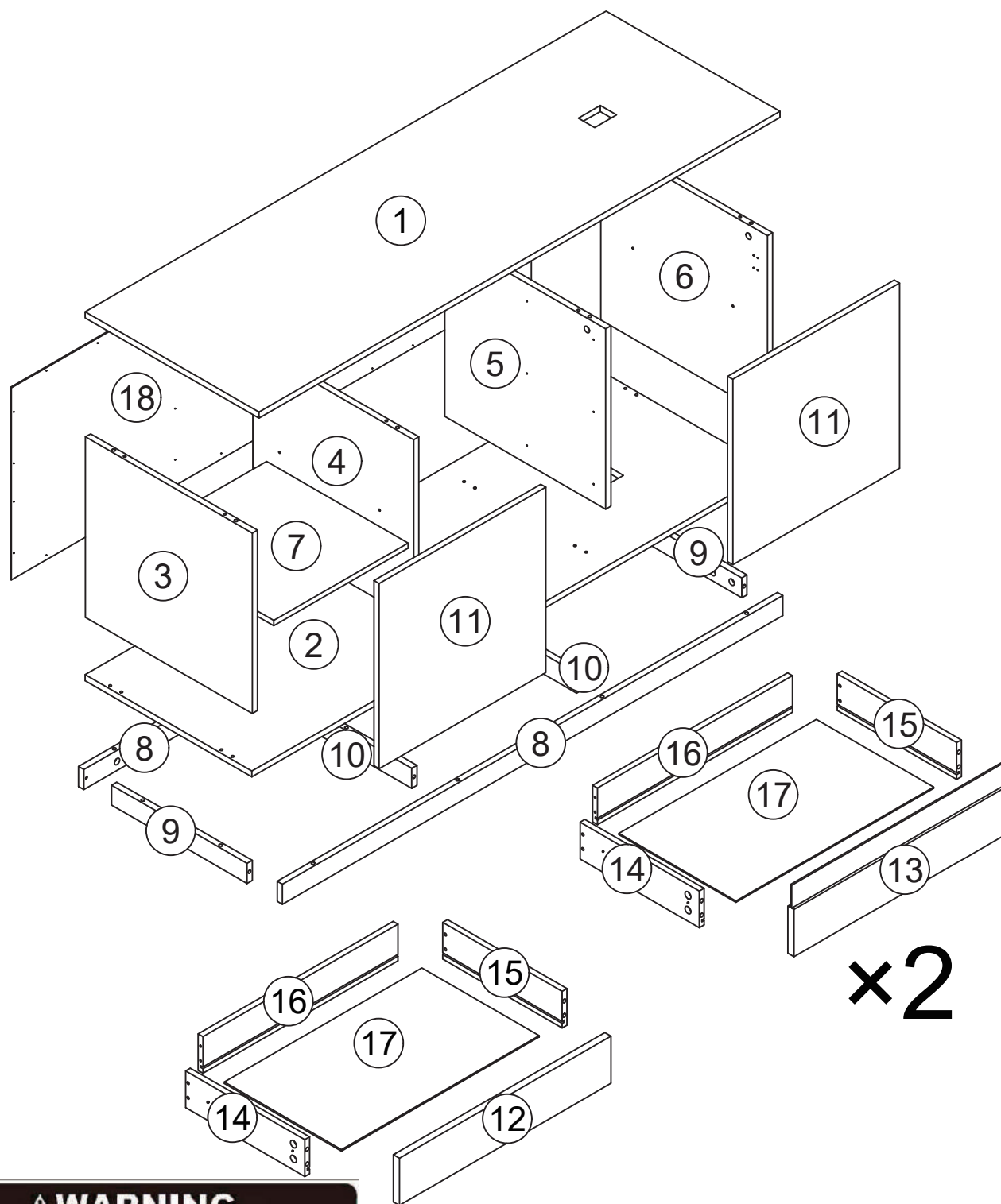

**⚠ WARNING**

Children have died from furniture tipover. To reduce the risk of furniture tipover:

- ALWAYS install Anti-tip device provided.
- NEVER put a TV on this product.
- NEVER allow children to stand, climb or hang on drawers, doors, or shelves.
- NEVER open more than one drawer at a time.
- Place heaviest items in the lowest drawers.

*This is a permanent label. Do not remove!*

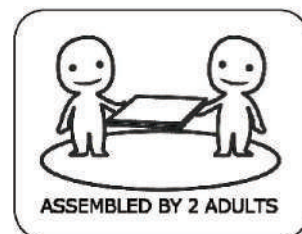

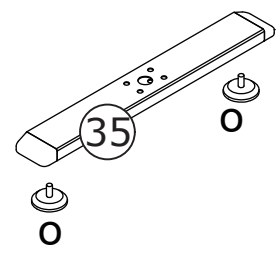
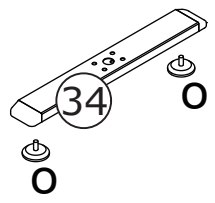
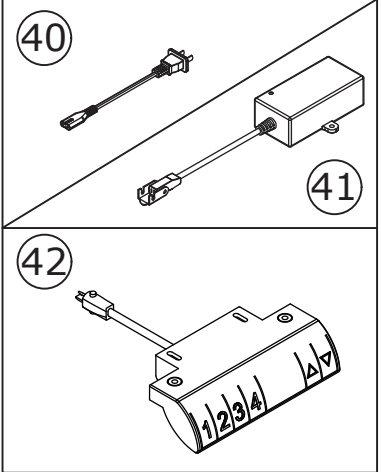
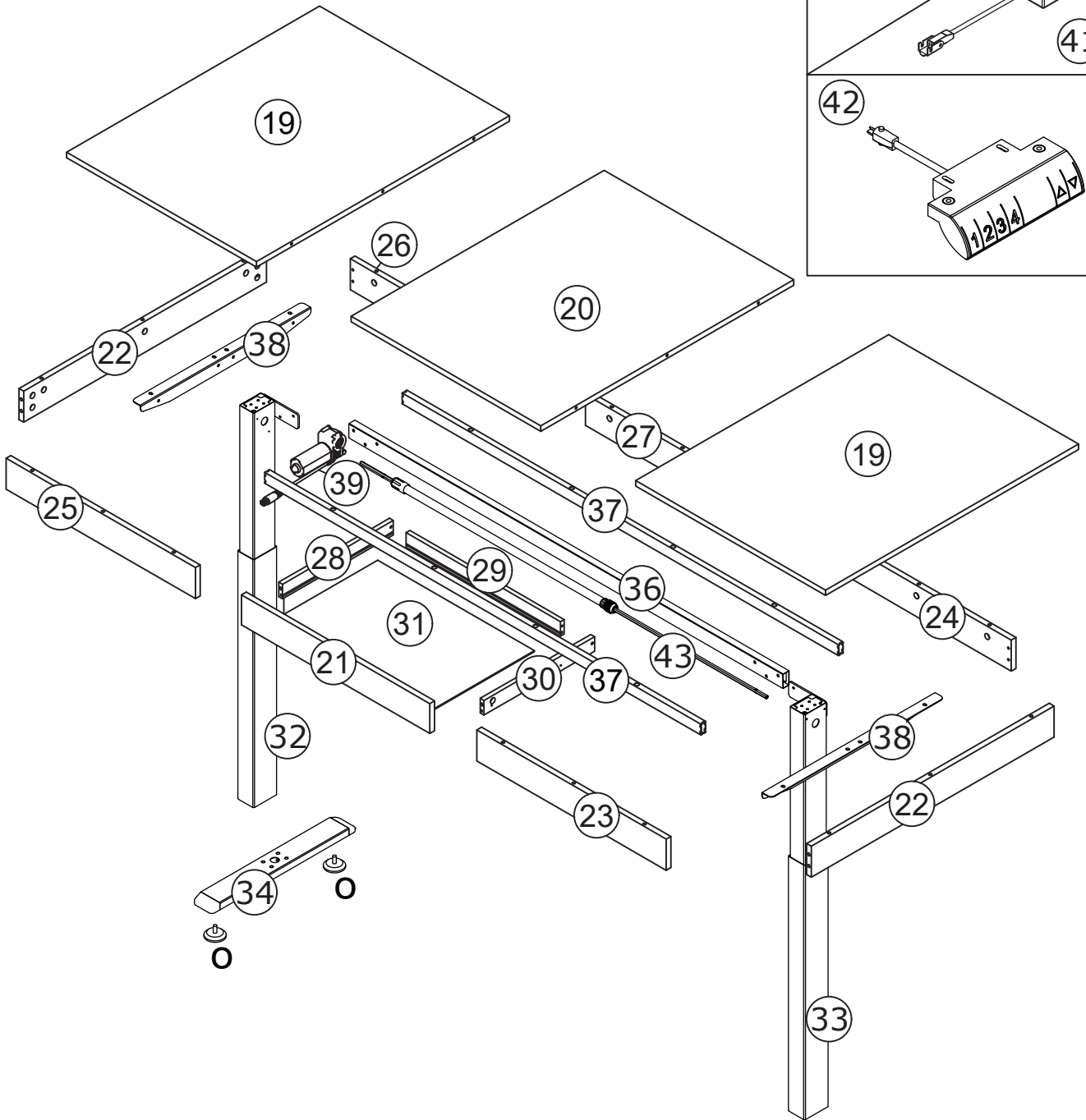

**⚠ WARNING**

Children have died from furniture tipover. To reduce the risk of furniture tipover:

- ALWAYS install Anti-tip device provided.
- NEVER put a TV on this product.
- NEVER allow children to stand, climb or hang on drawers, doors, or shelves.
- NEVER open more than one drawer at a time.
- Place heaviest items in the lowest drawers.

*This is a permanent label. Do not remove!*

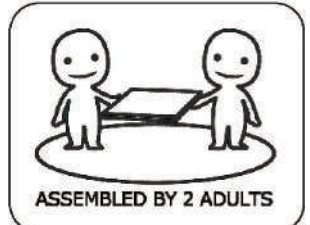

1

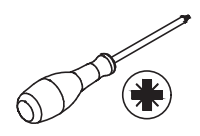
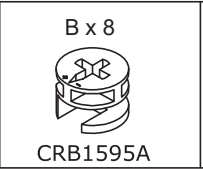
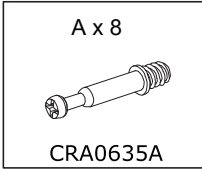

Screw eccentric rod(A) into board 8 at first.

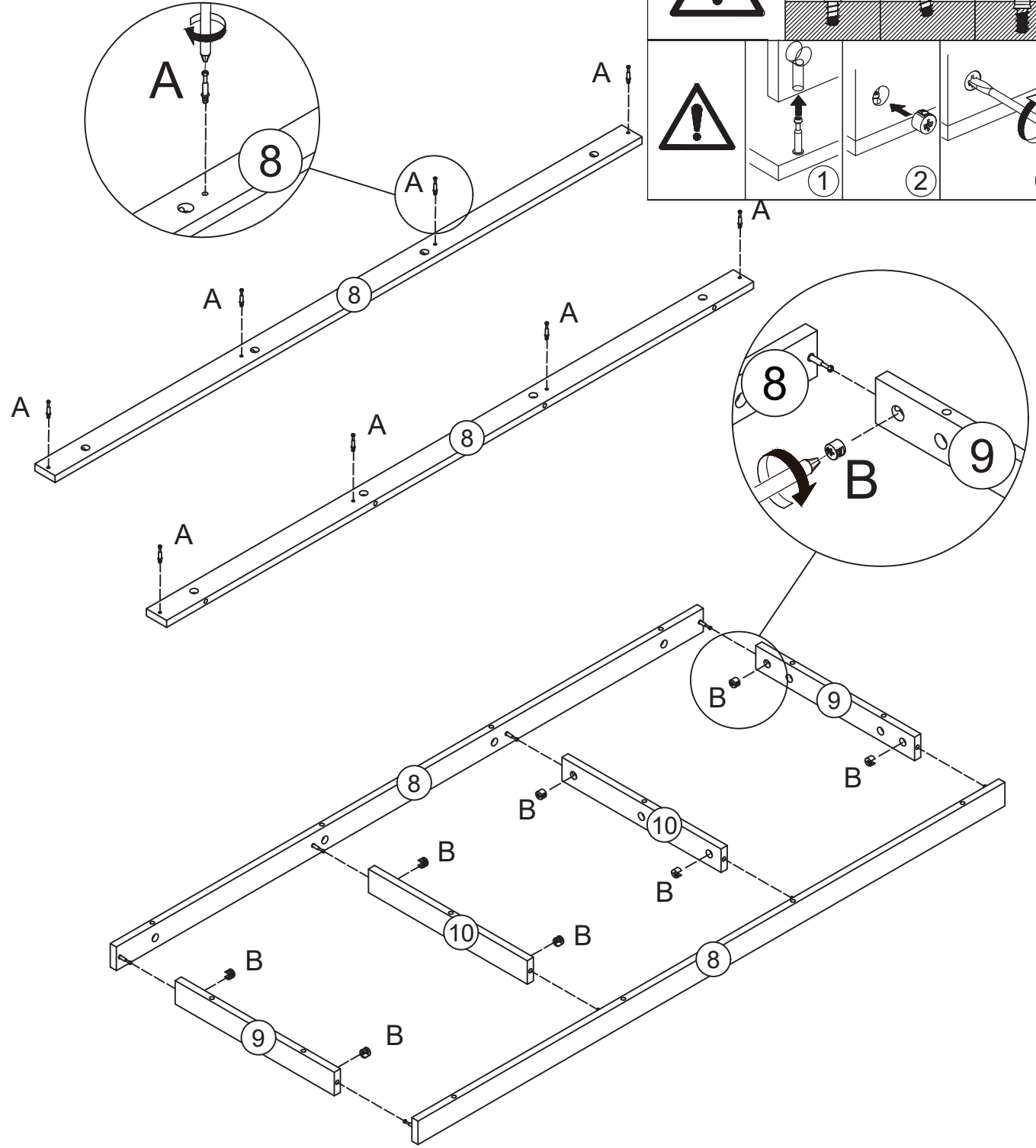
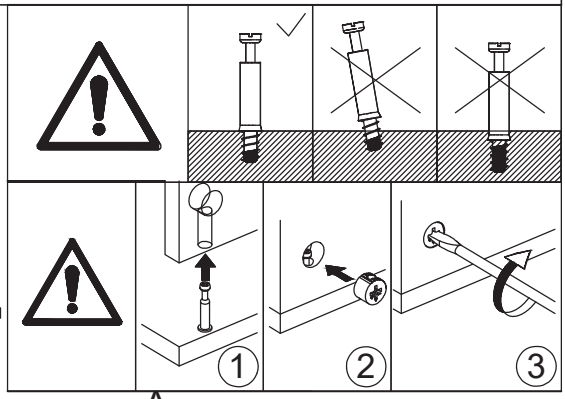

Connect board 8, 9 and 10, add cam lock (B) into board 9 and 10 then turn clockwise to tighten as shown.

2

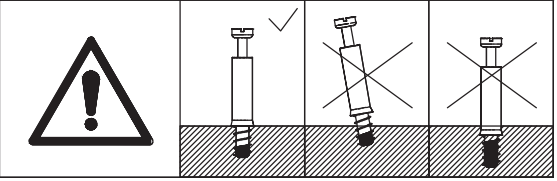
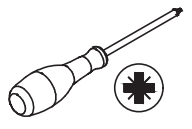
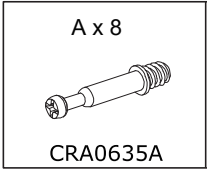

Screw eccentric rod (A) into board 1 at first.

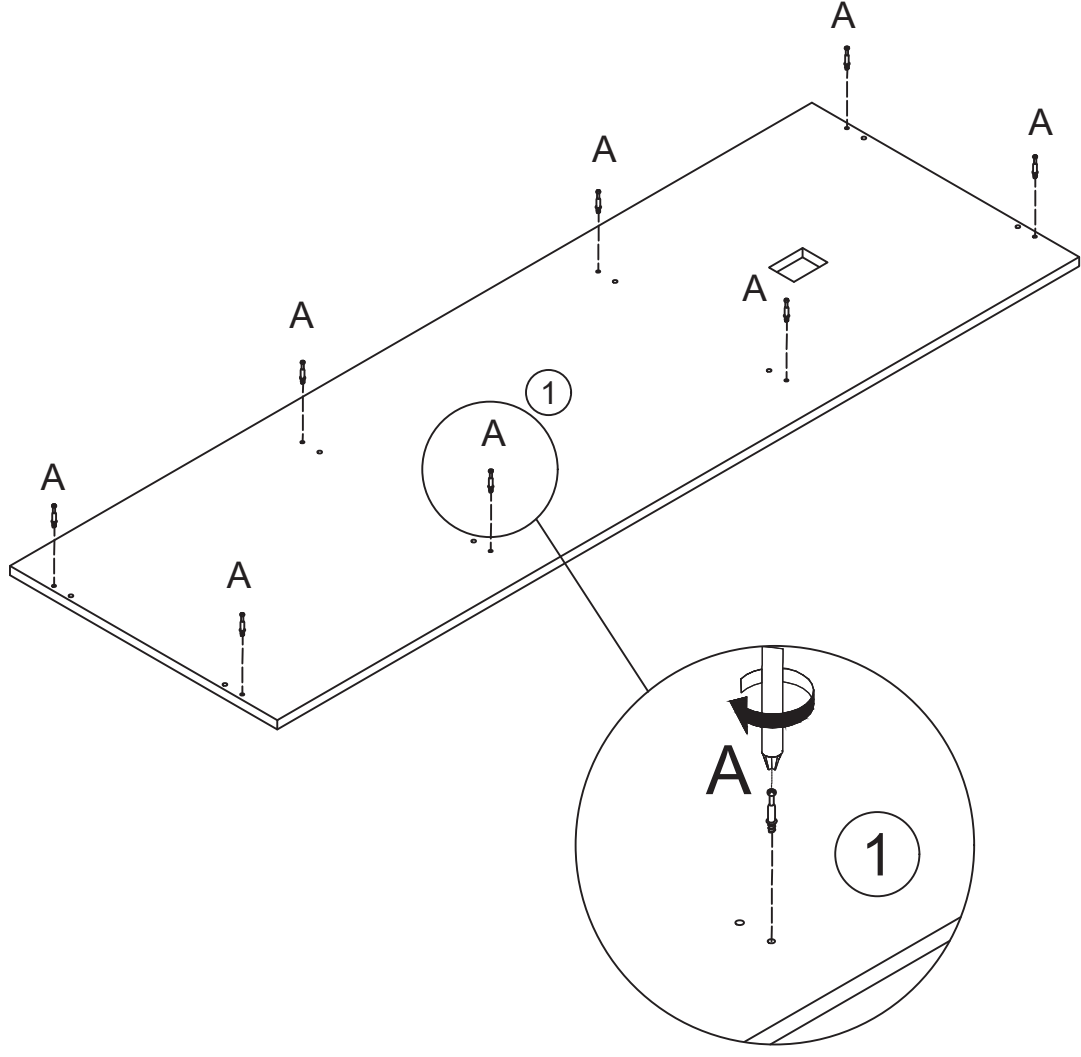

3

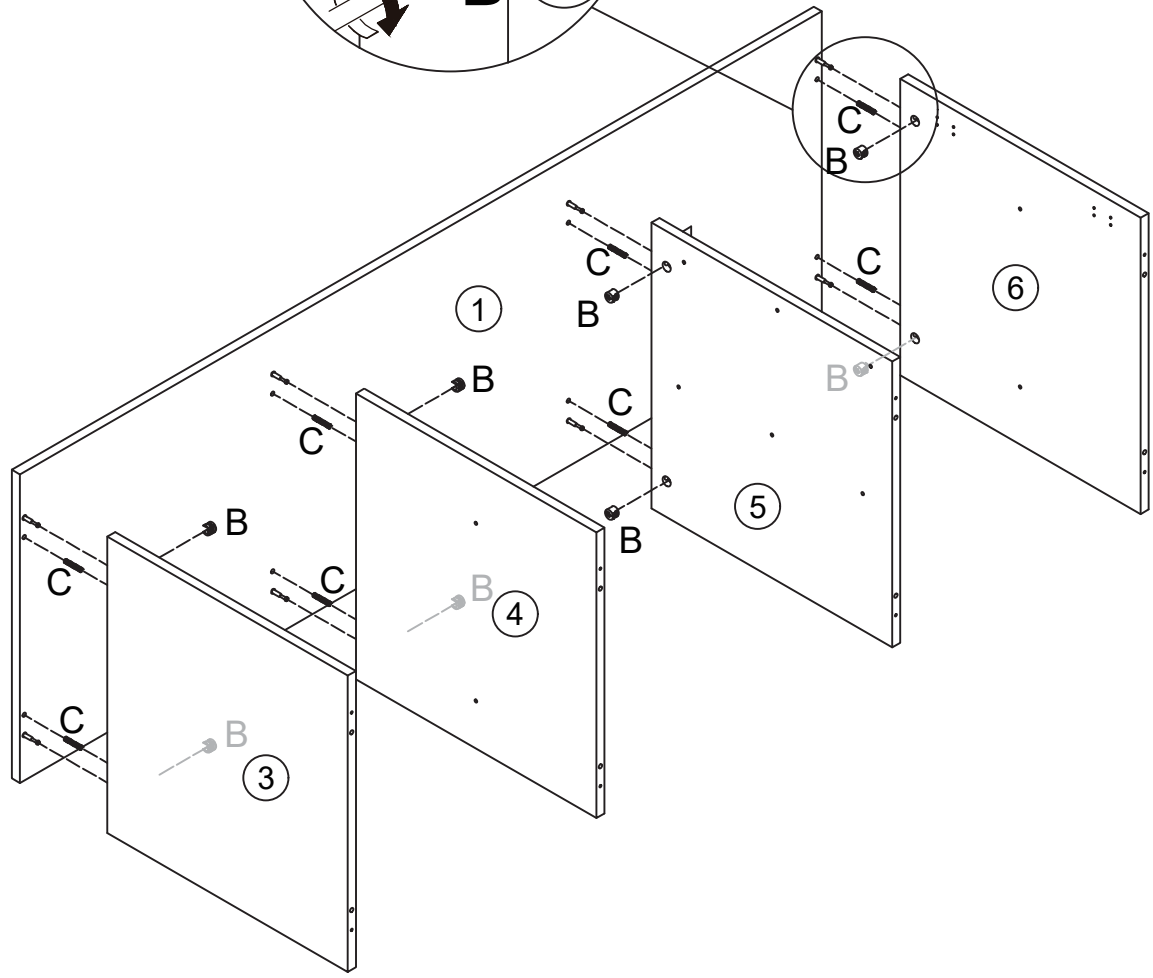
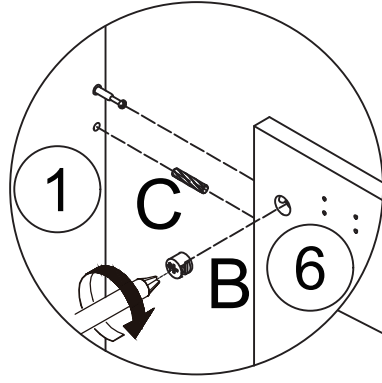
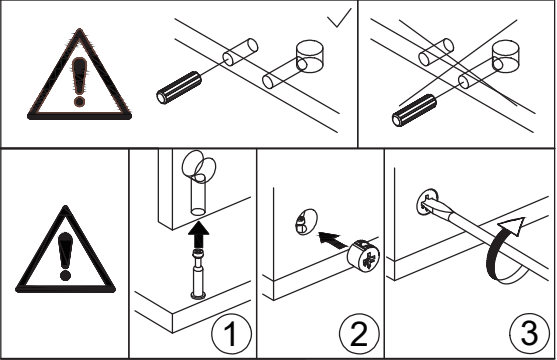

Connect board 1 to board 3, 4, 5 and 6 with wooden dowel (C) ,add cam lock(B) into and turn clockwise to tighten as shown.

4

A x 14  
CRA0635A

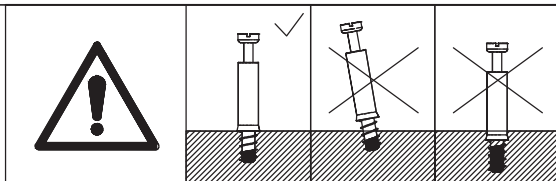
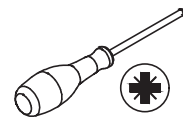
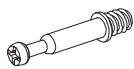

Screw eccentric rod(A) into board 2 at first.

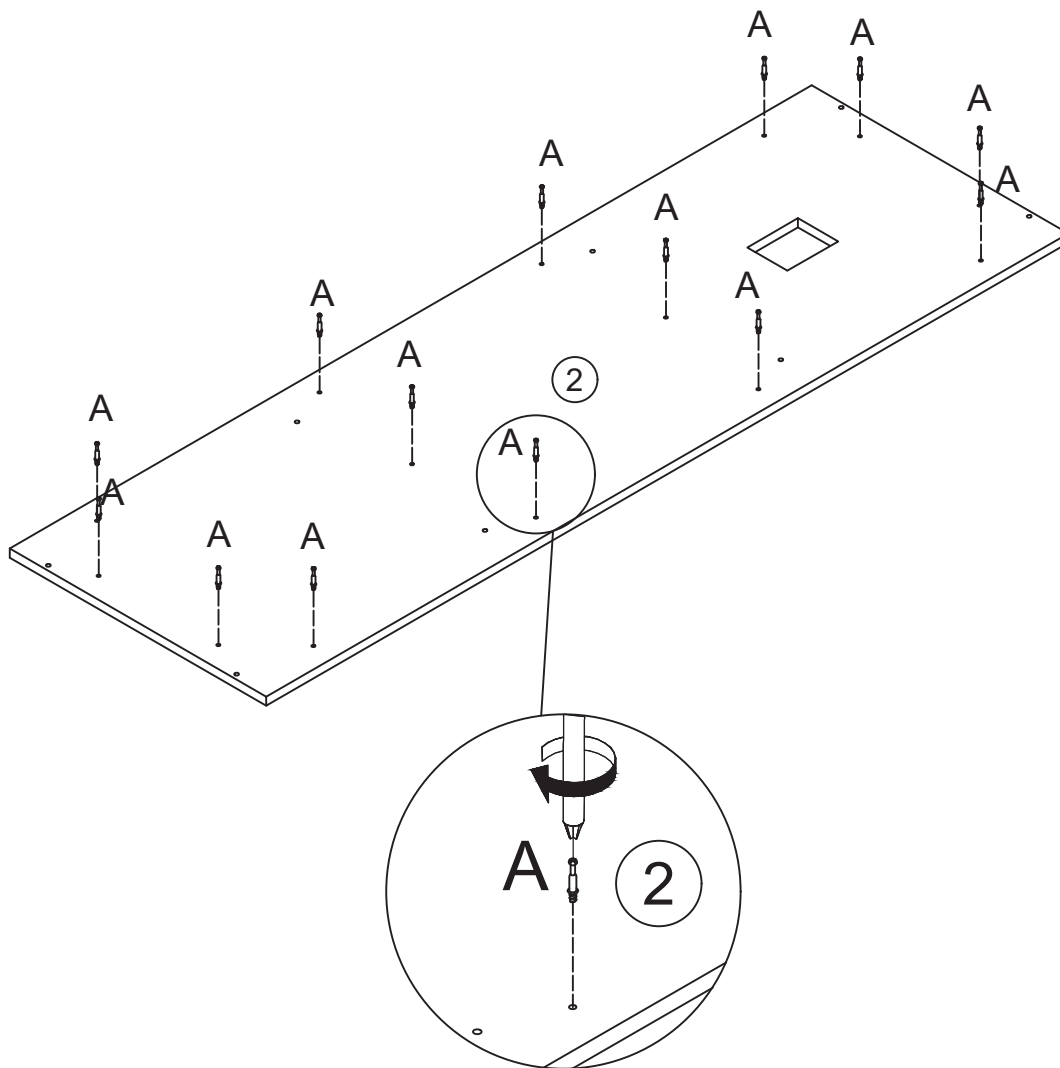

5

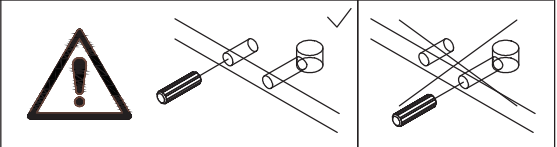

Connect board 2 to board 3, 4, 5 and 6 with wooden dowel (C) , and fix with screw (D) as shown.

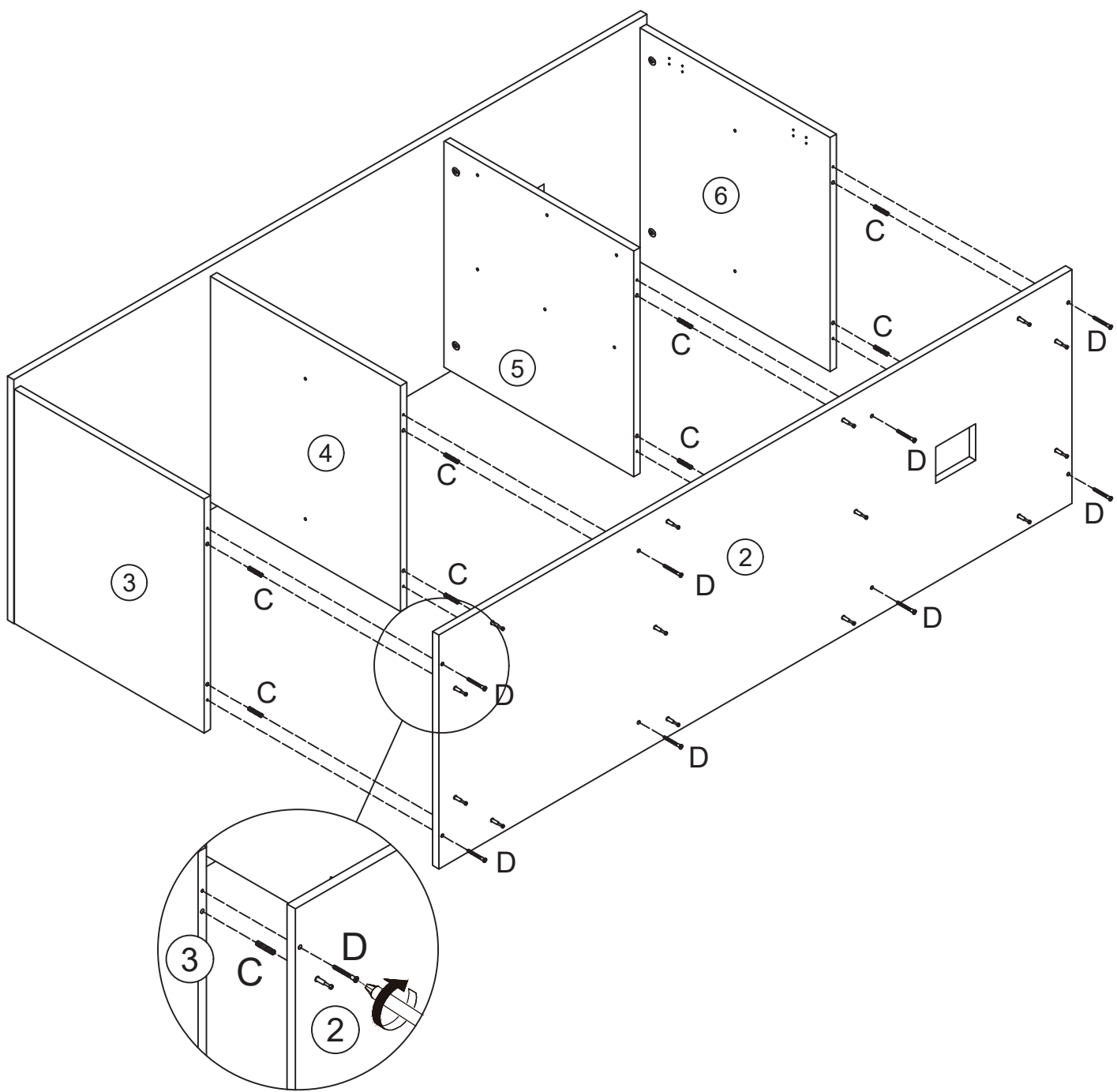

6

B x 14  
CRB1595A

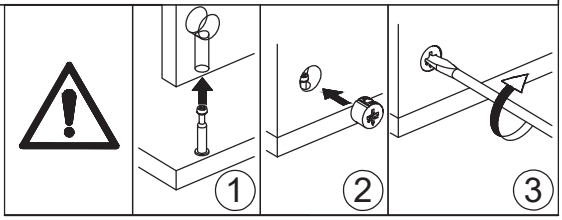
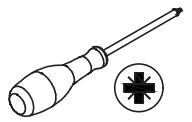

Connect Panel 8, Panel 9 and Panel 10 to Panel 2. Insert the eccentric cam (B) and tighten it by rotating clockwise.

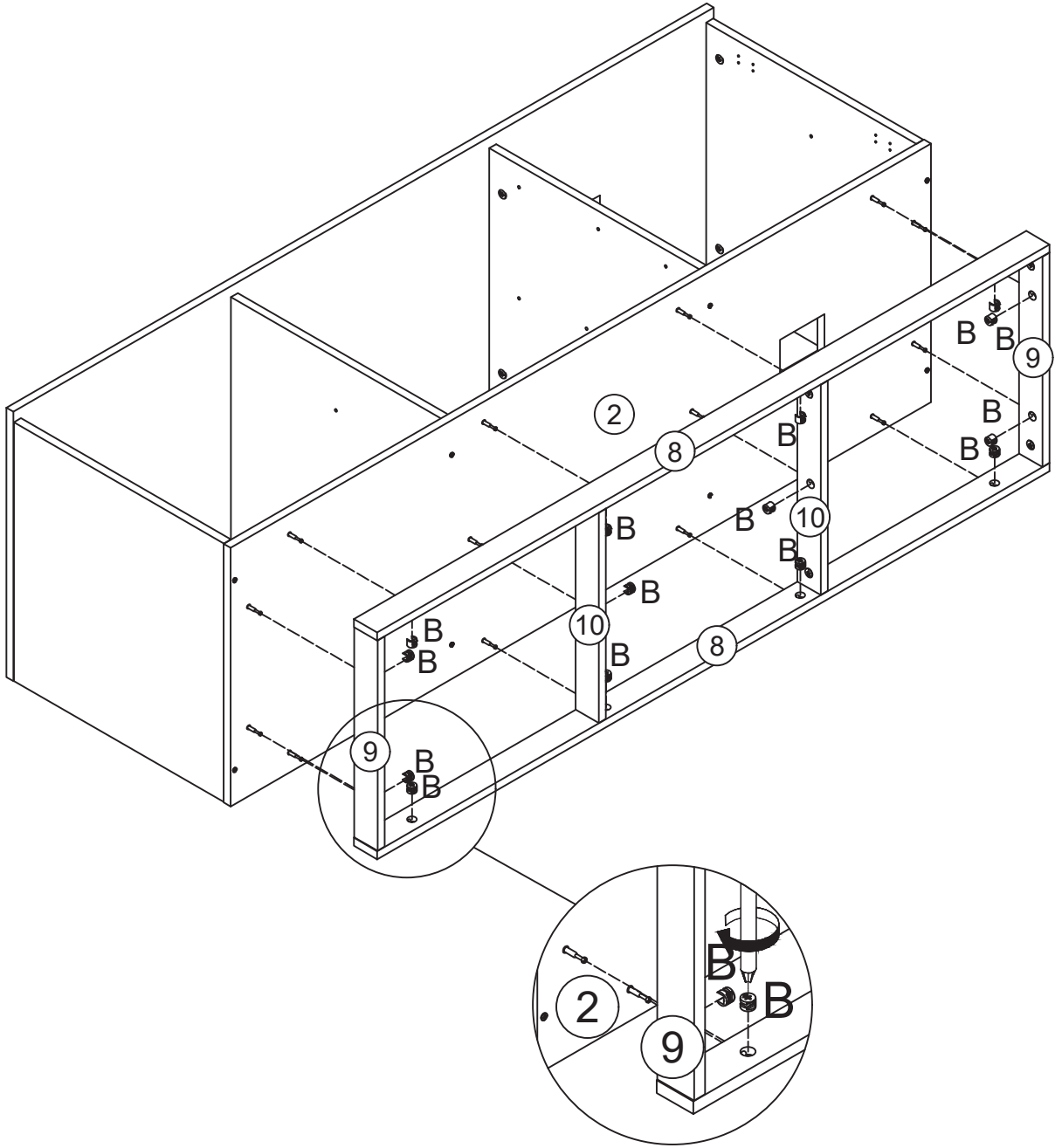

7

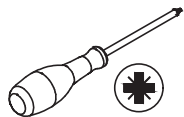
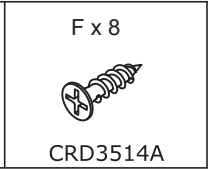
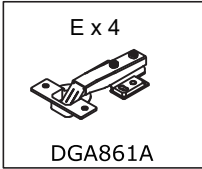

Fix hinge (E) to board 11 with screw (F) as shown.

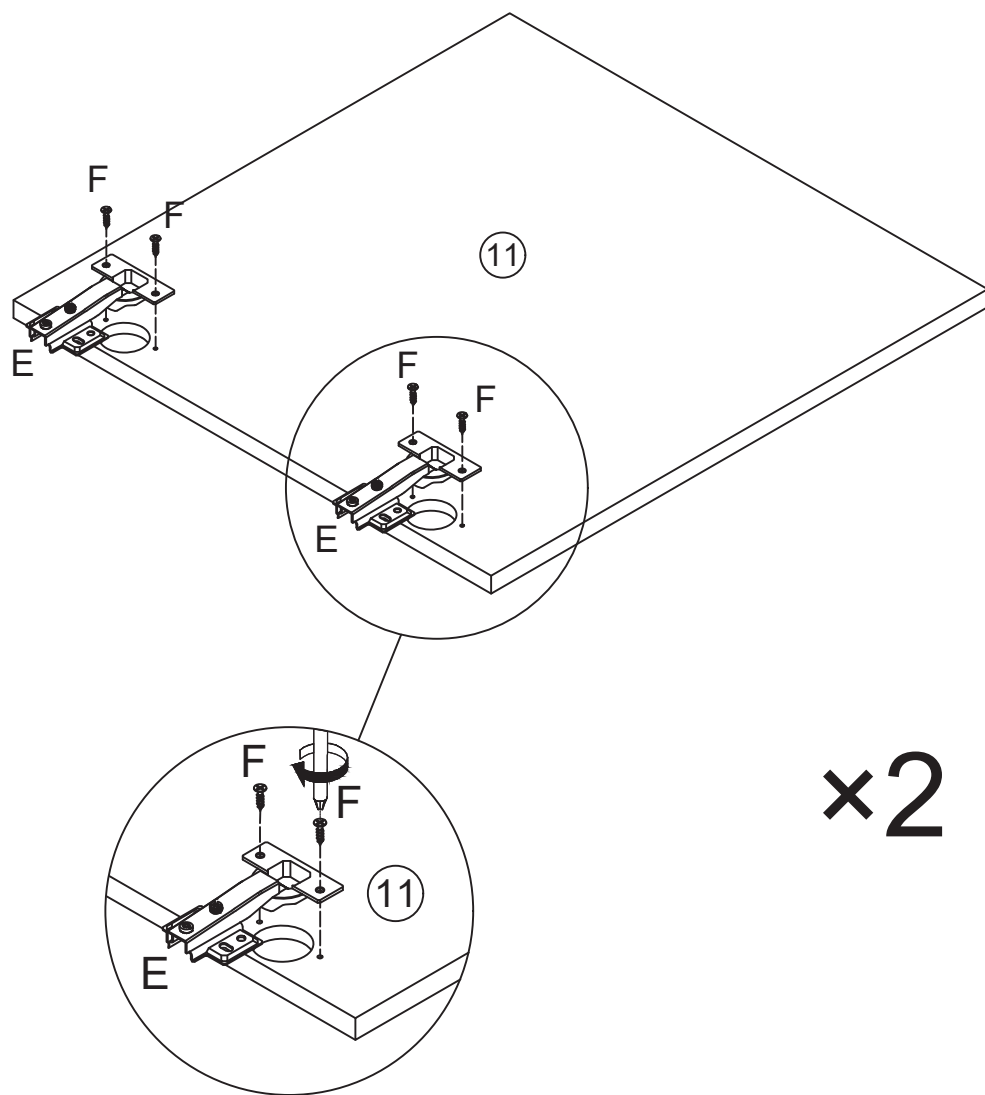

8

Insert steel frame 32 into board 1 and 2 as shown.

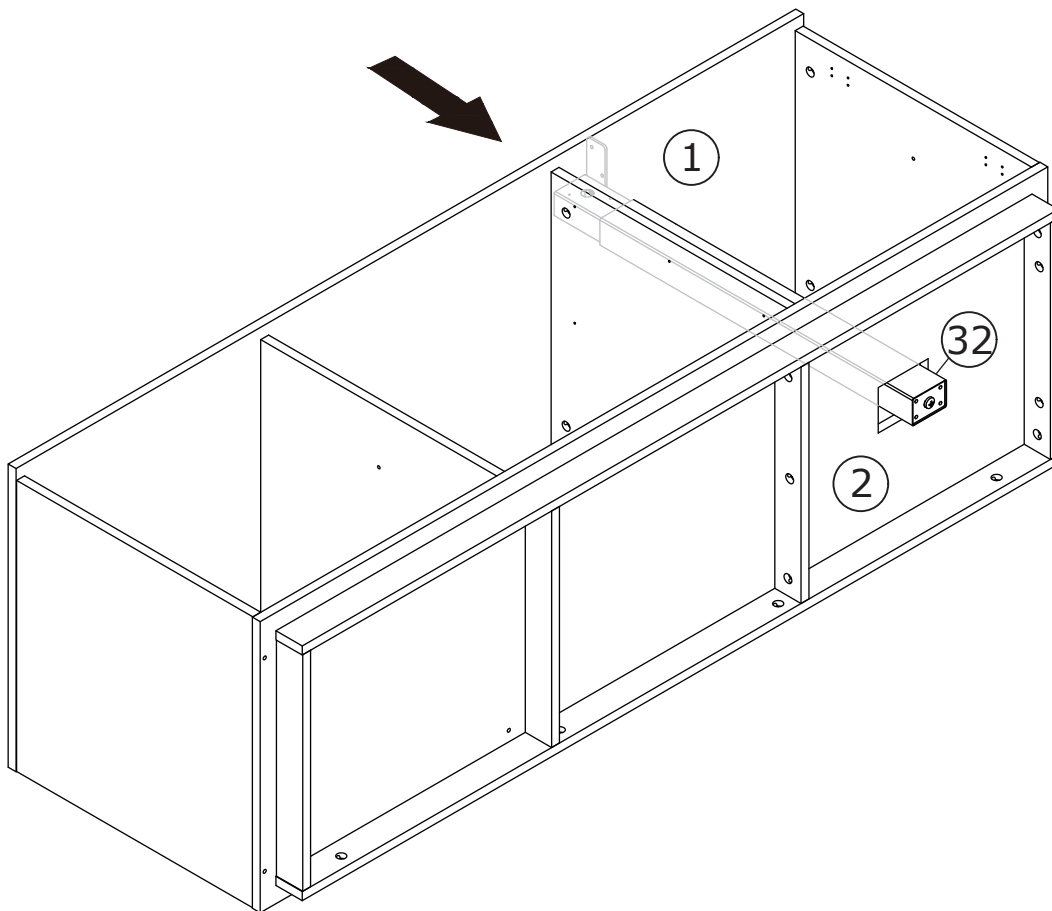

9

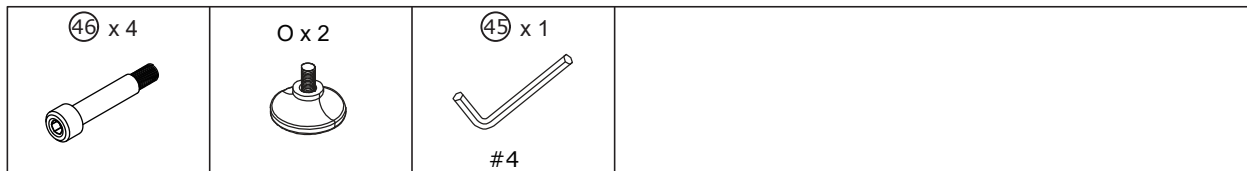

As shown in the figure, attach Component (O) to Steel Frame 34, then fasten Steel Frame 34 to Steel Frame 32 using Screws (46).

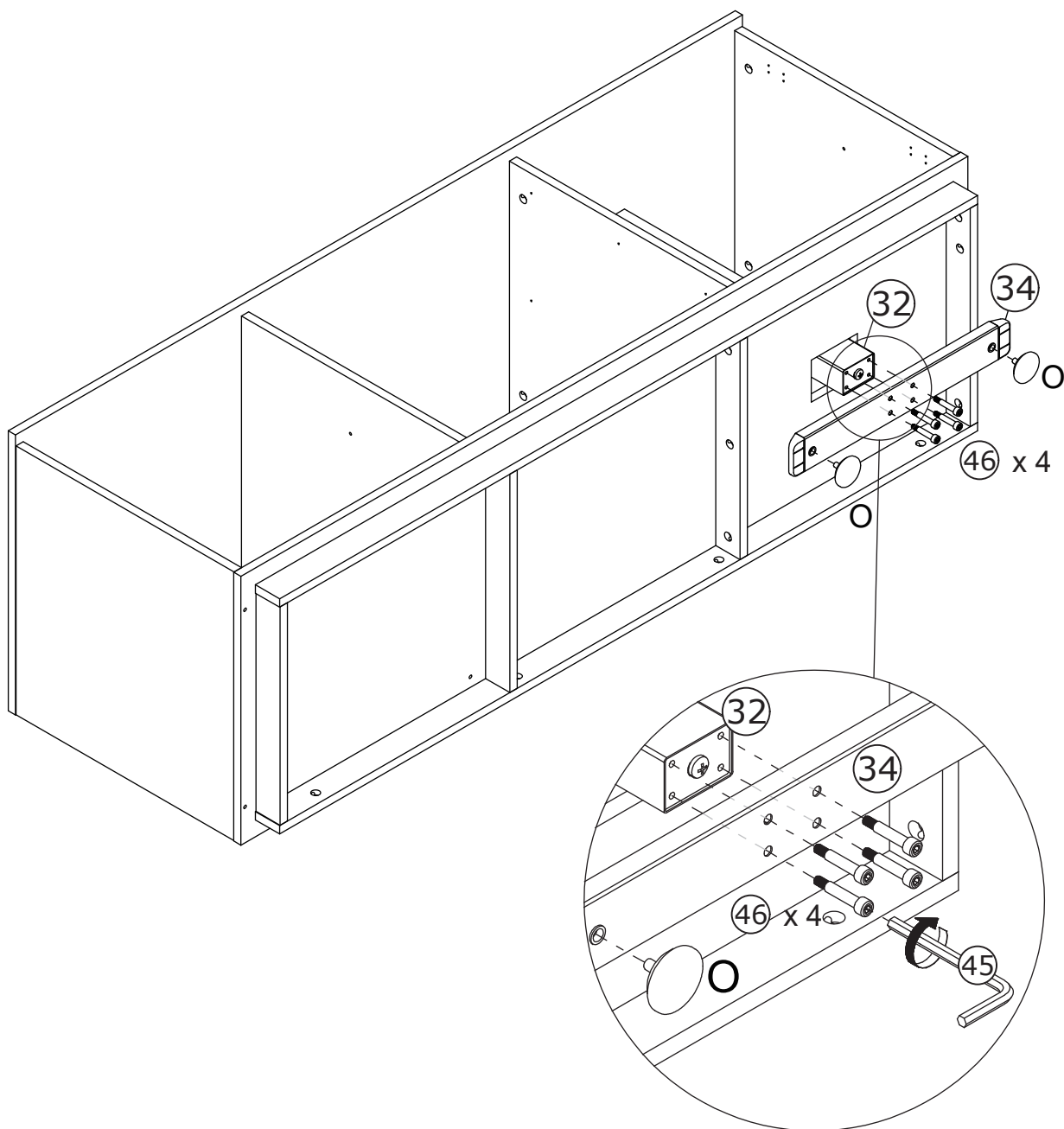





10

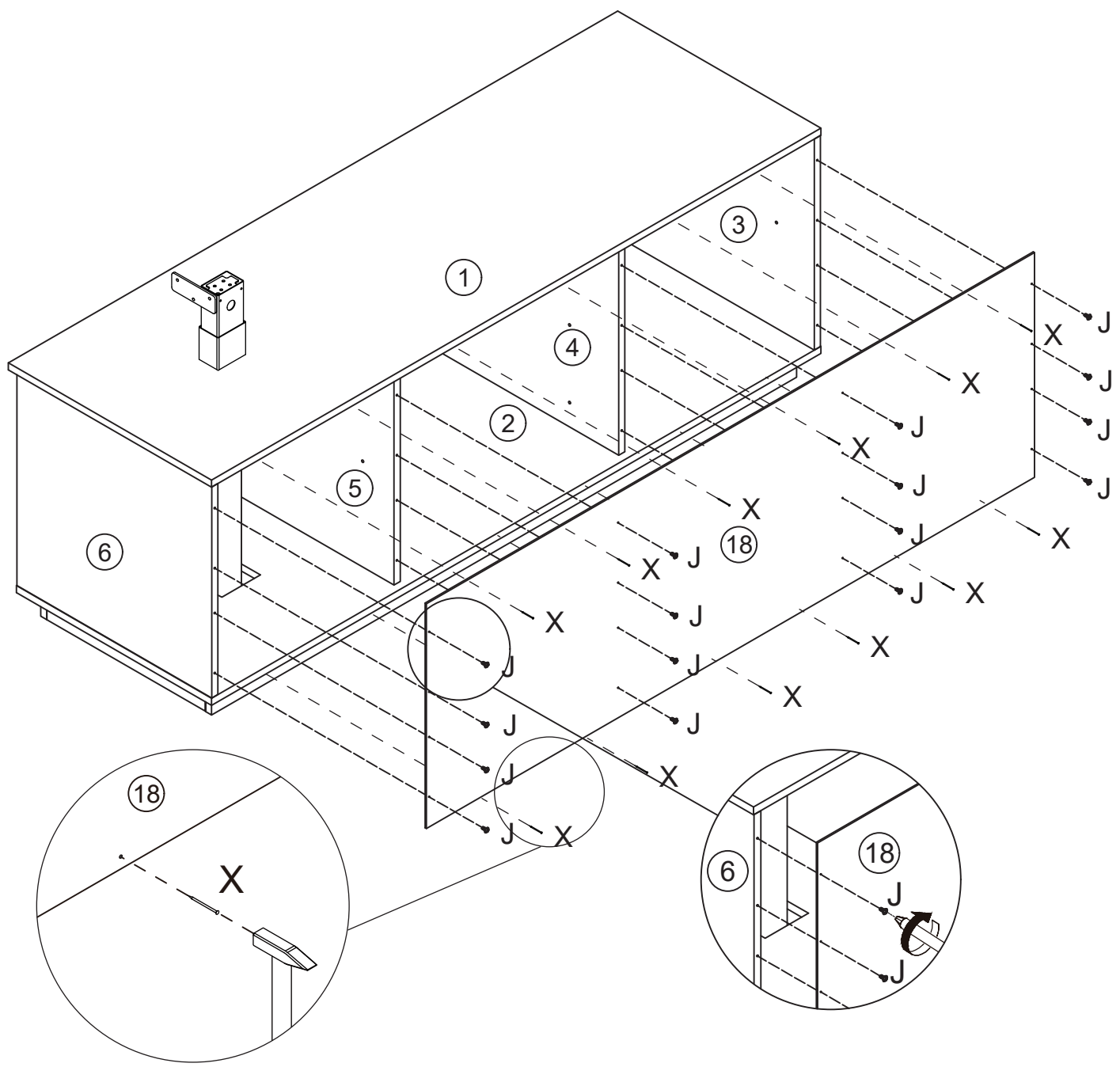

As shown in the diagram, connect Panel 18 to Panels 3, 4, 5, and 6 using Screws (J). Connect Panel 18 to Panels 1 and 2 using Component (X).

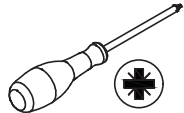

# 11

<p>F x 16              CRD3514A</p>	<p>U x 4  </p>	<p>G x 3            G-1              #3508 12"</p>	<p>H x 12              CRD3512A</p>	
--	---	---	--	---

Assemble door 11 to the cabinet by fixing hinge (E) with screw (F) as shown.

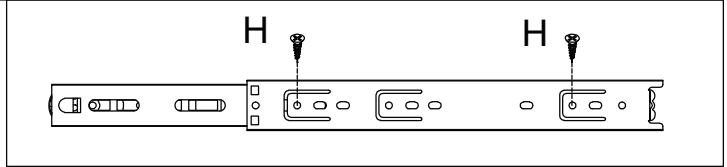

Fix rail (G-1) to board 4 and board 5 with screw (H) as shown.

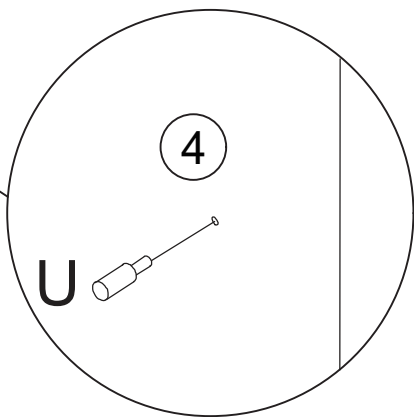
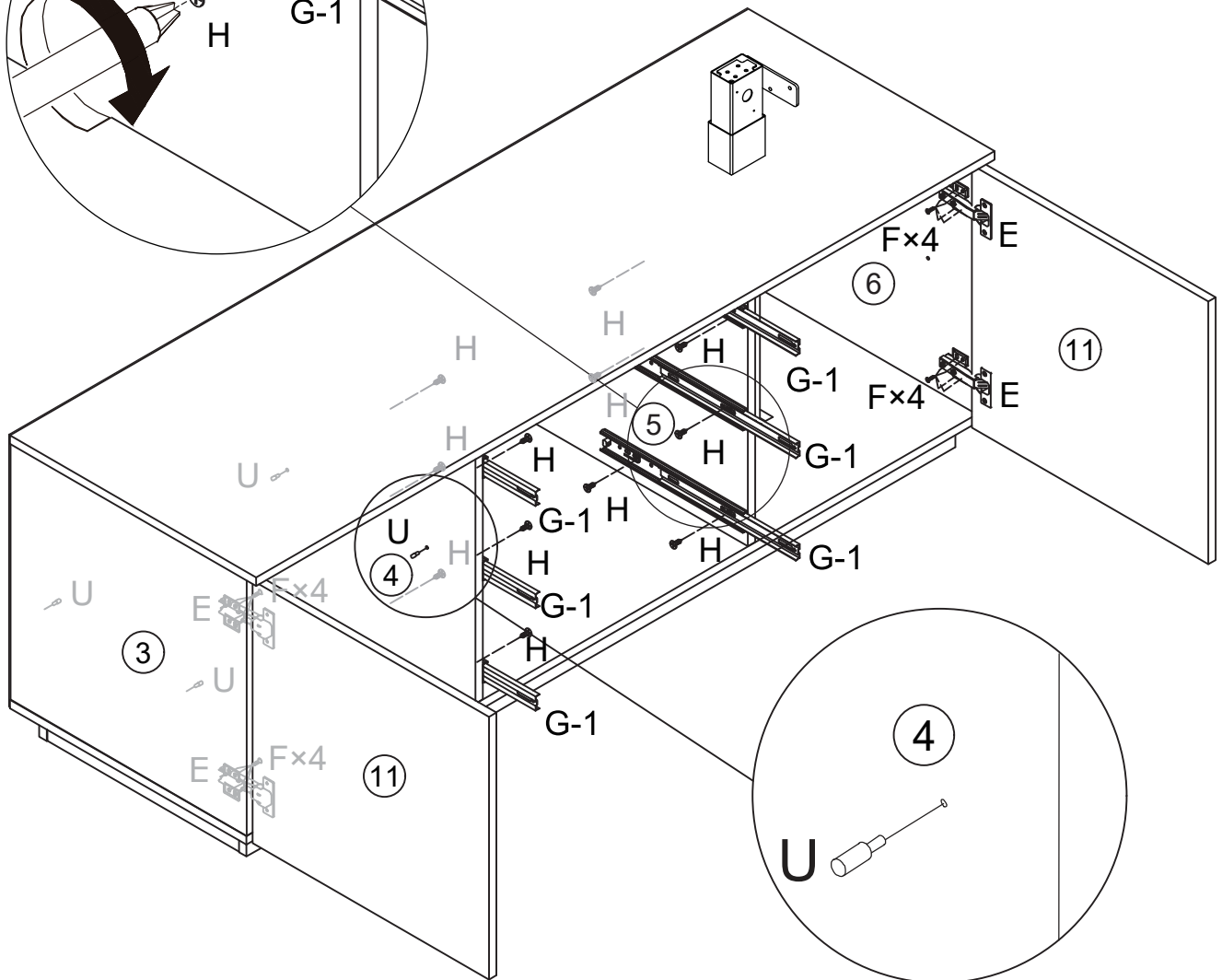
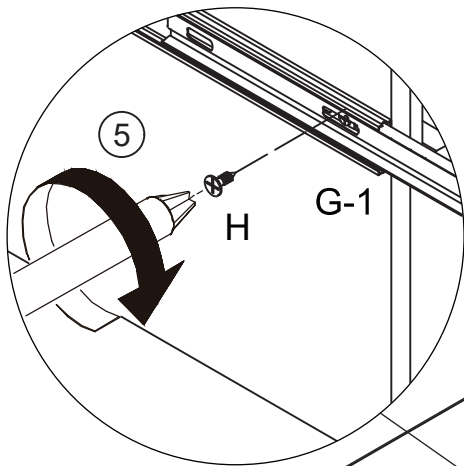

Add layer pin (U) into board 3 and board 4 as shown.

12

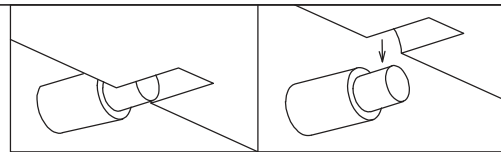

Put shelf 7 on layer pin as shown.

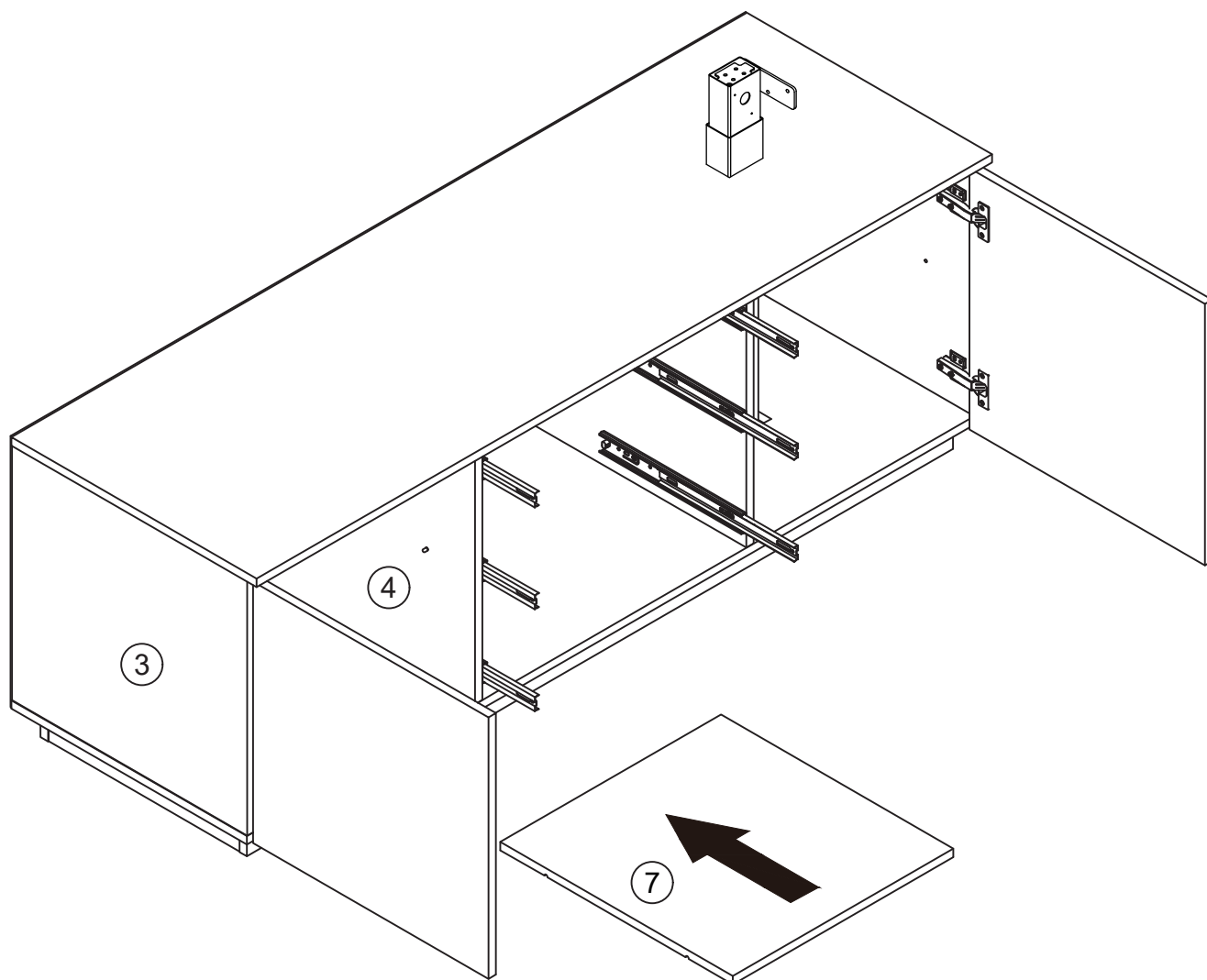

13

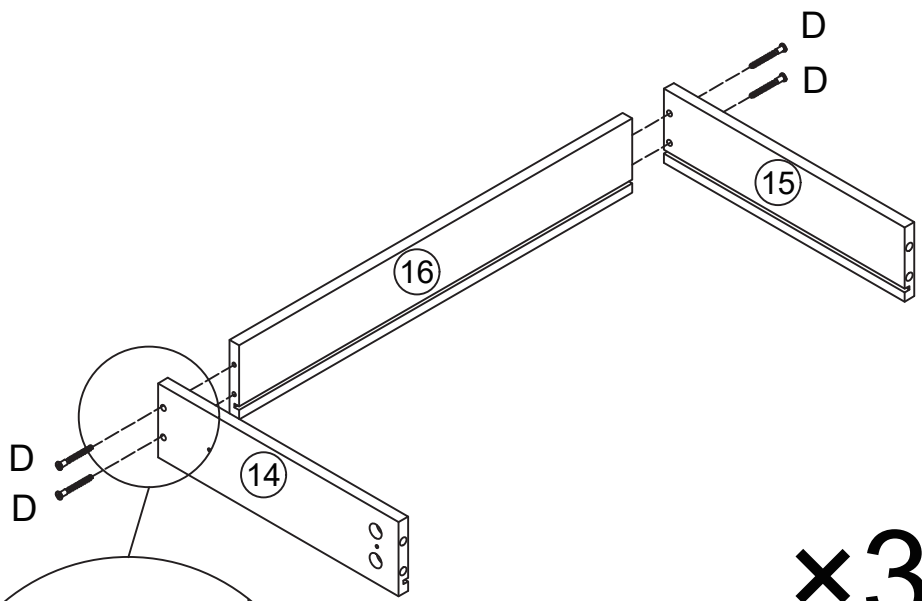
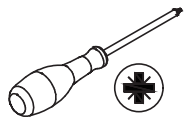
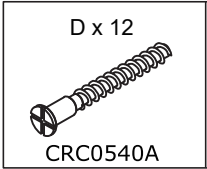

×3

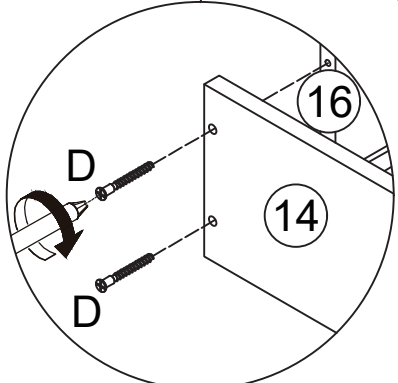

Connect board 16 to board 14 and 15 with screw (D) as shown.

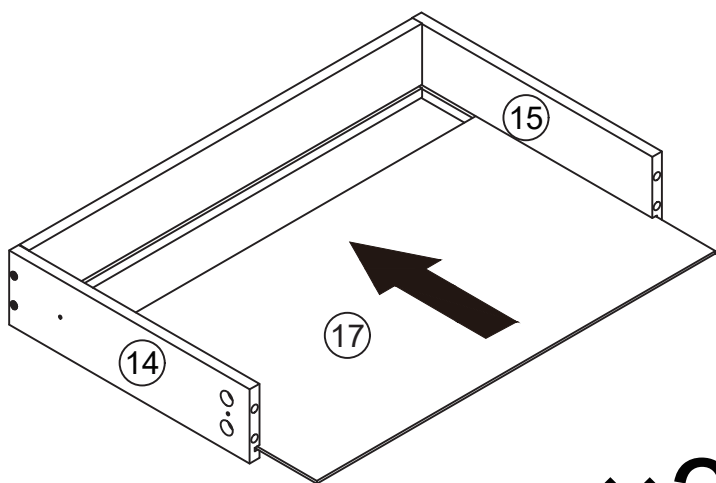

×3

Slide board 17 into grooves as shown.

14

A x 12  
CRA0635A

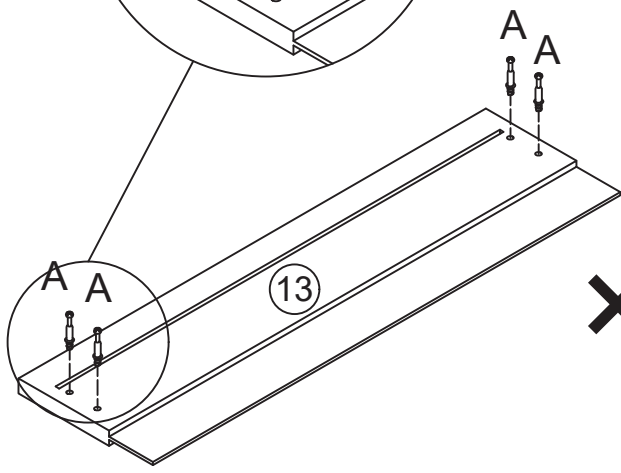
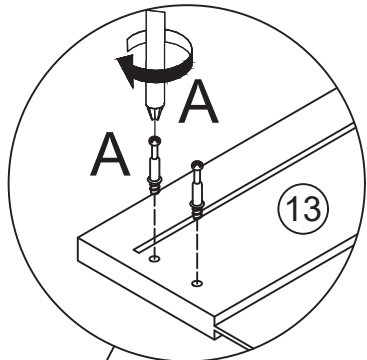
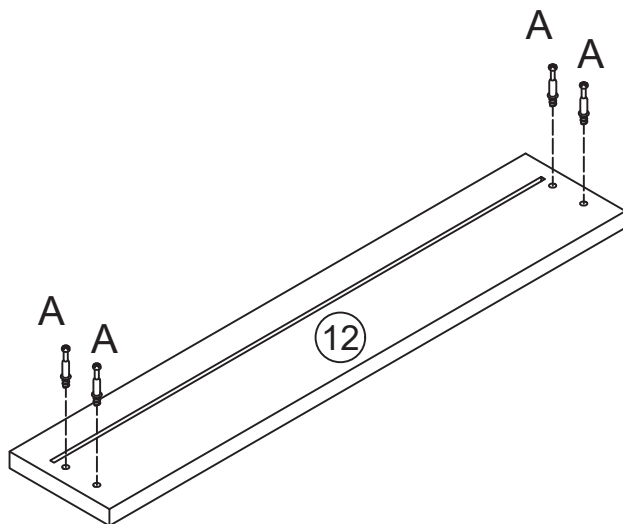
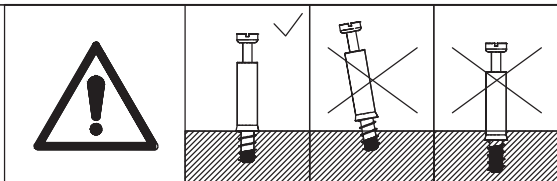
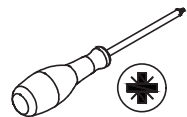

Screw eccentric rod(A) into board 12 and 13 at first.

15

B x 12  
CRB1595A

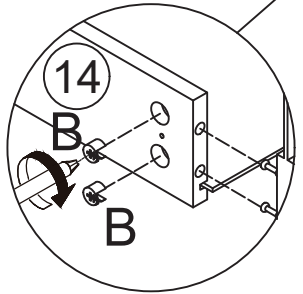
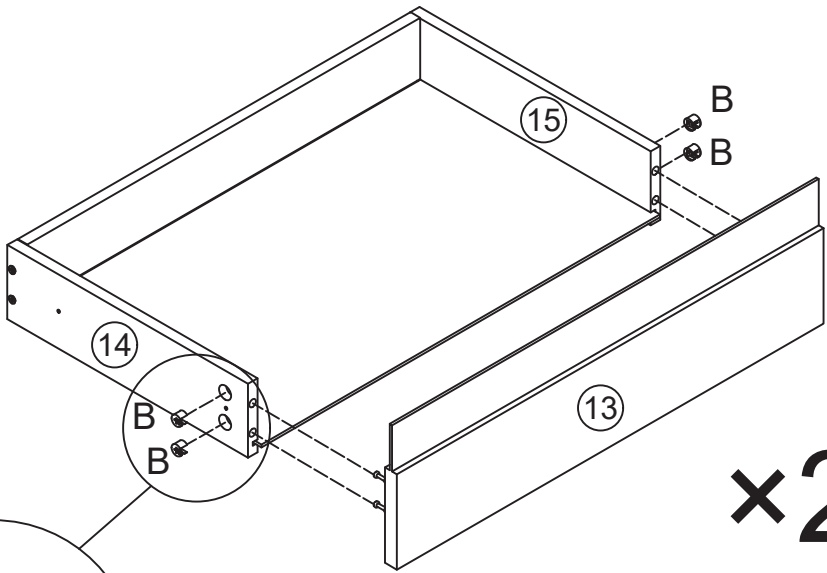
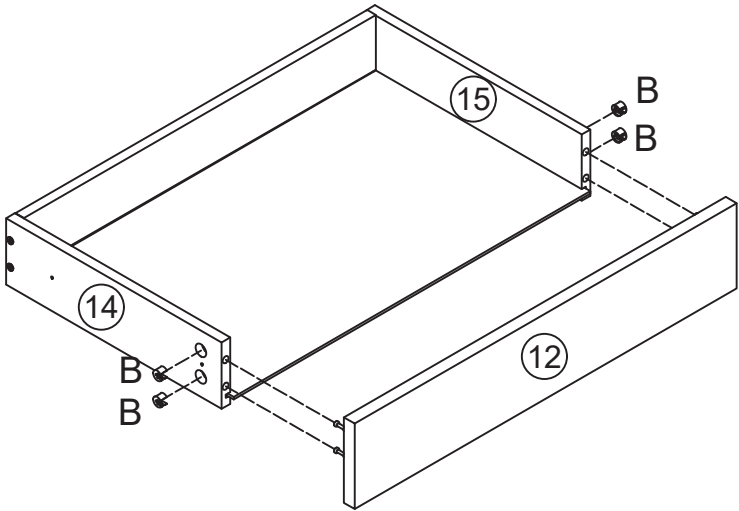
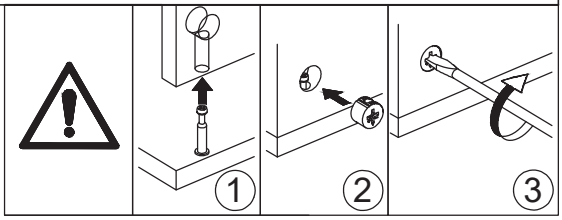
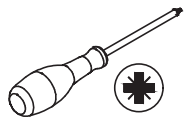

Connect board 12 and 13 to the drawer, add cam lock(B) into and turn clockwise to tighten as shown.

16

G x 3 G-2 #3508 12"	H x 12 CRD3512A	
---------------------------	--------------------	---

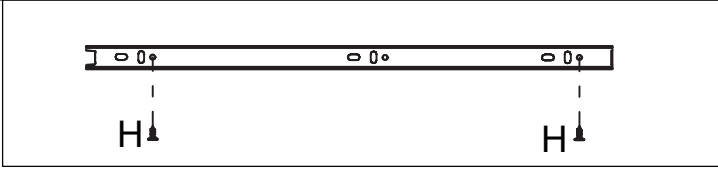

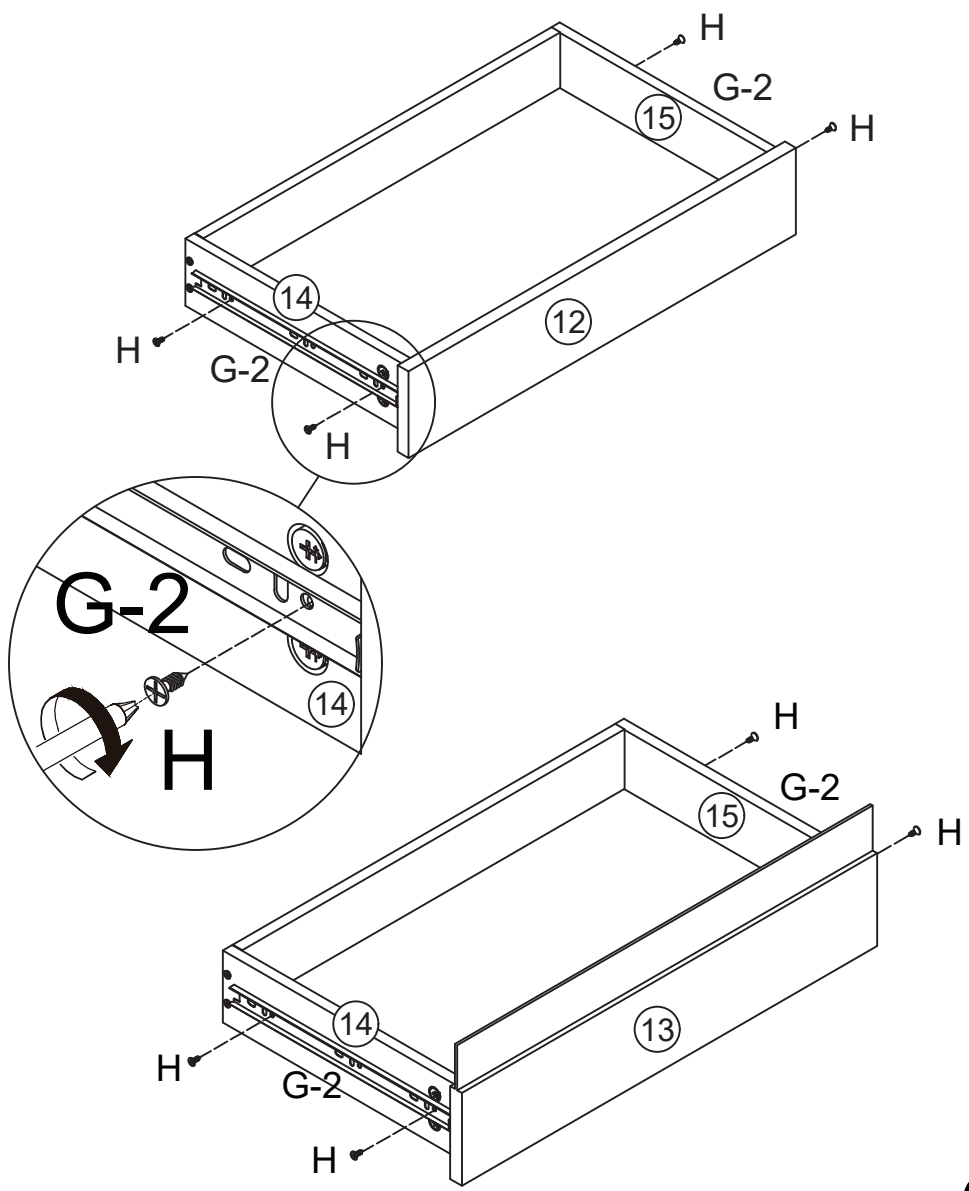

Fix rail (G-2) to board 14 and board 15 with screw (H) as shown.

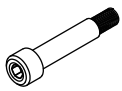

x2

17

<p>46 x 4</p> 	<p>O x 2</p> 	<p>45 x 1</p>  <p>#4</p>	
---	--	---	--

As shown in the figure, mount Component (O) onto Steel Frame 35, and fasten Steel Frame 35 to Steel Frame 33 with Screws (46).

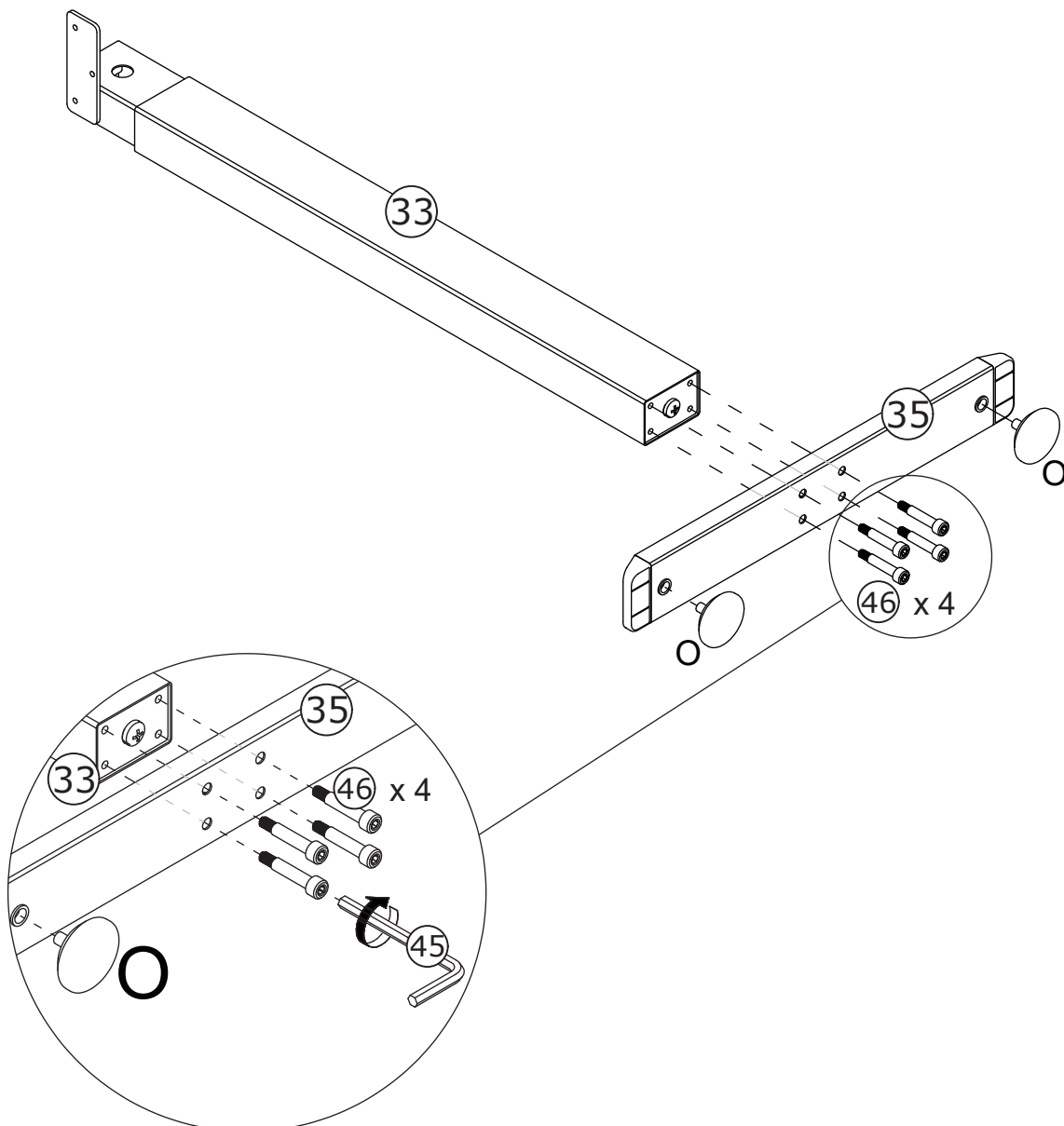

18



Align rails, slide all drawers in.

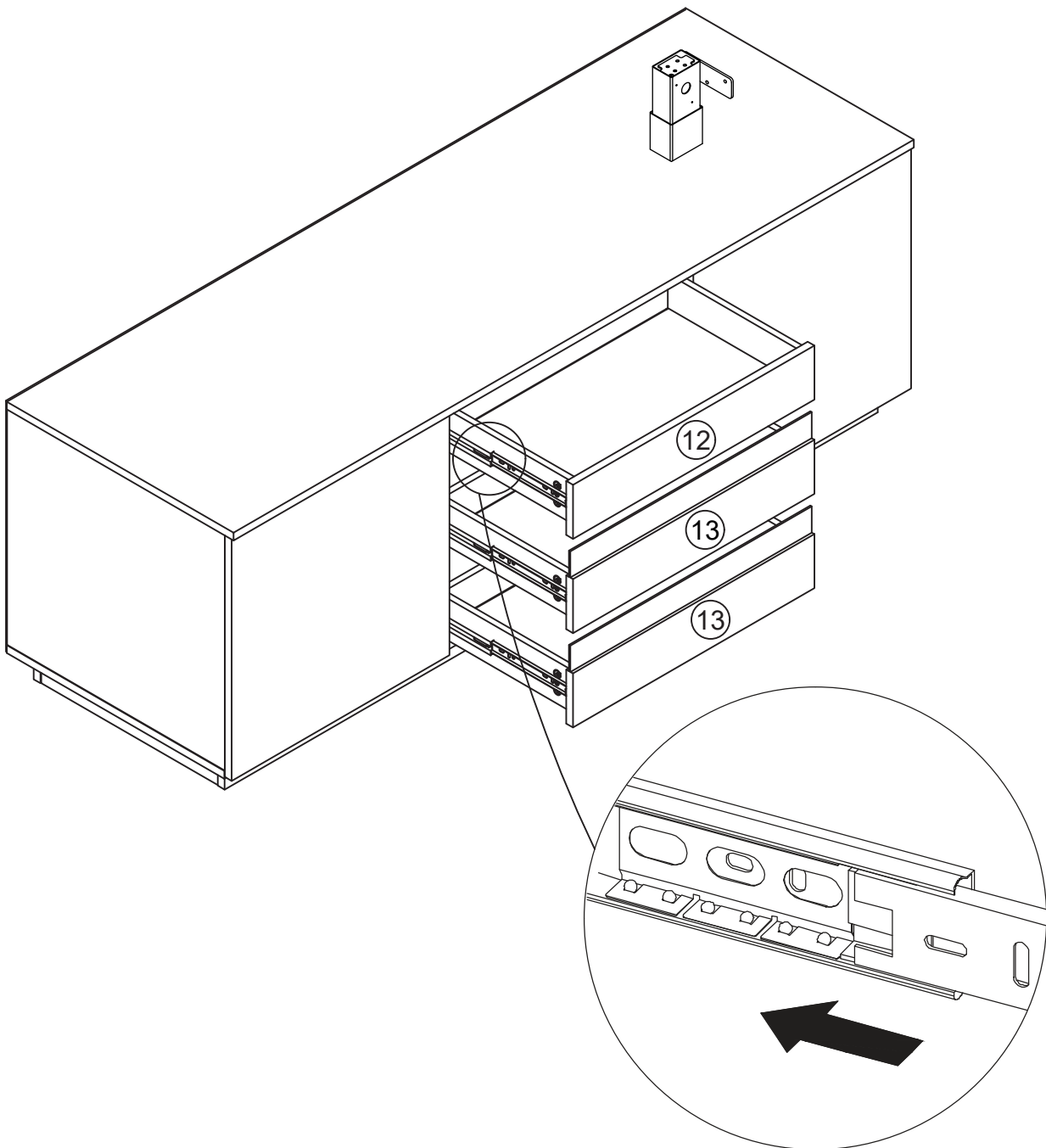

19

<p>L x 6</p>  <p>Ø 6 x 8 mm</p>	<p>45 x 1</p>  <p>#4</p>	
--	---	--

As shown in the figure, connect Steel Frame 32, Steel Frame 33 and Steel Frame 36 using Screws (L).

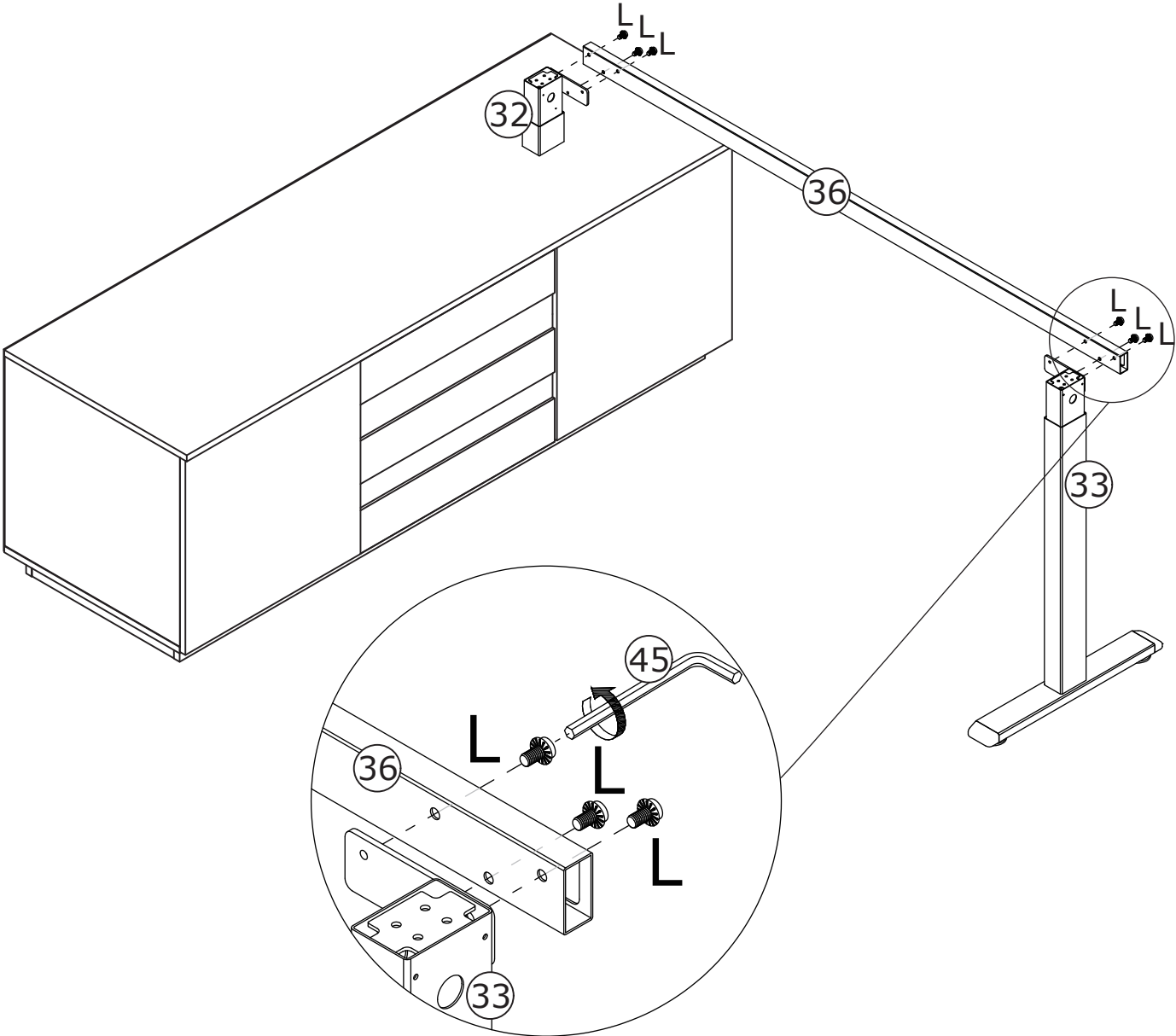

20



As shown in the figure, press the steel frames 32, 33 and 36 down to their lowest positions.

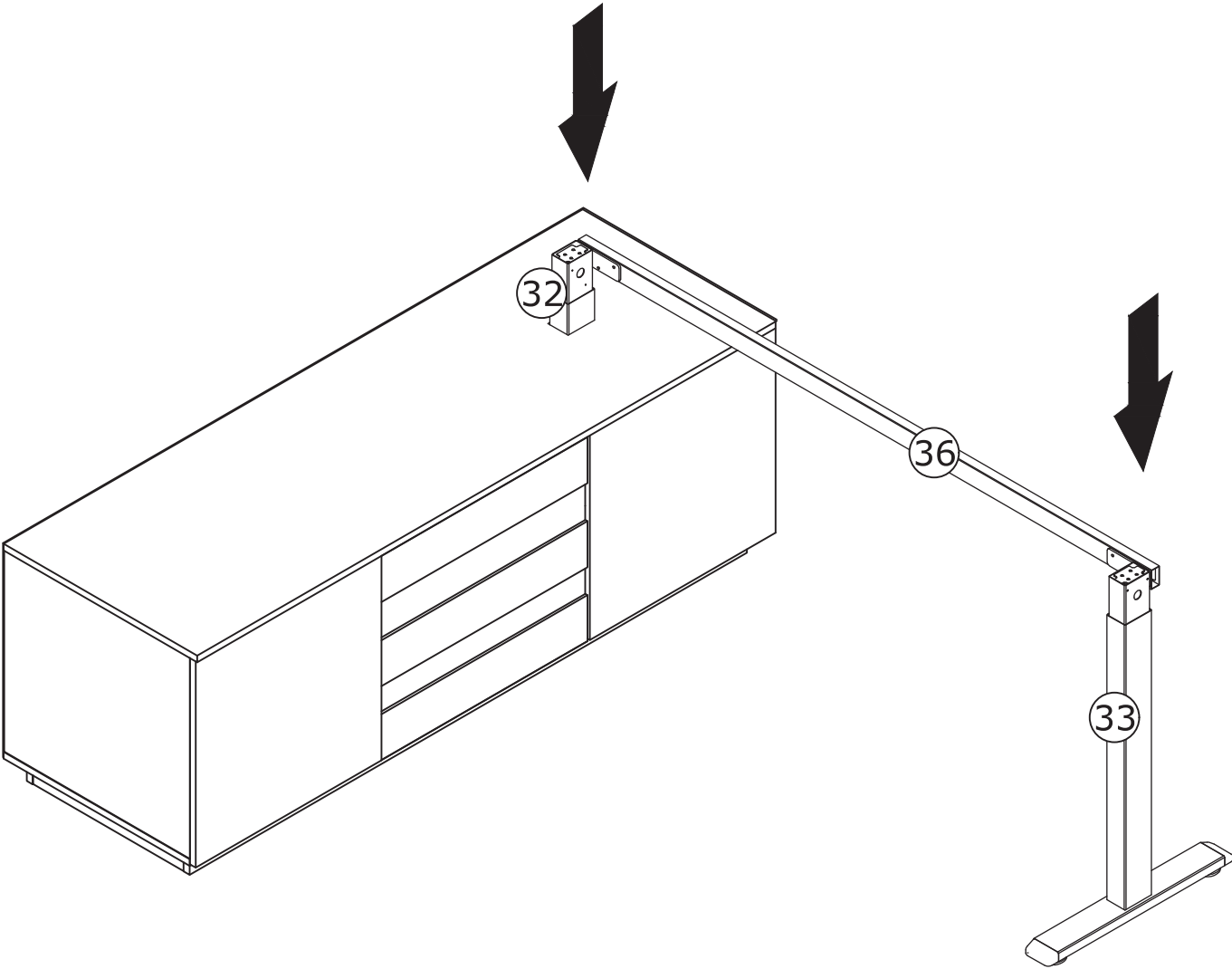

21

As shown in the figure, install component (39-2) onto motor (39-1).

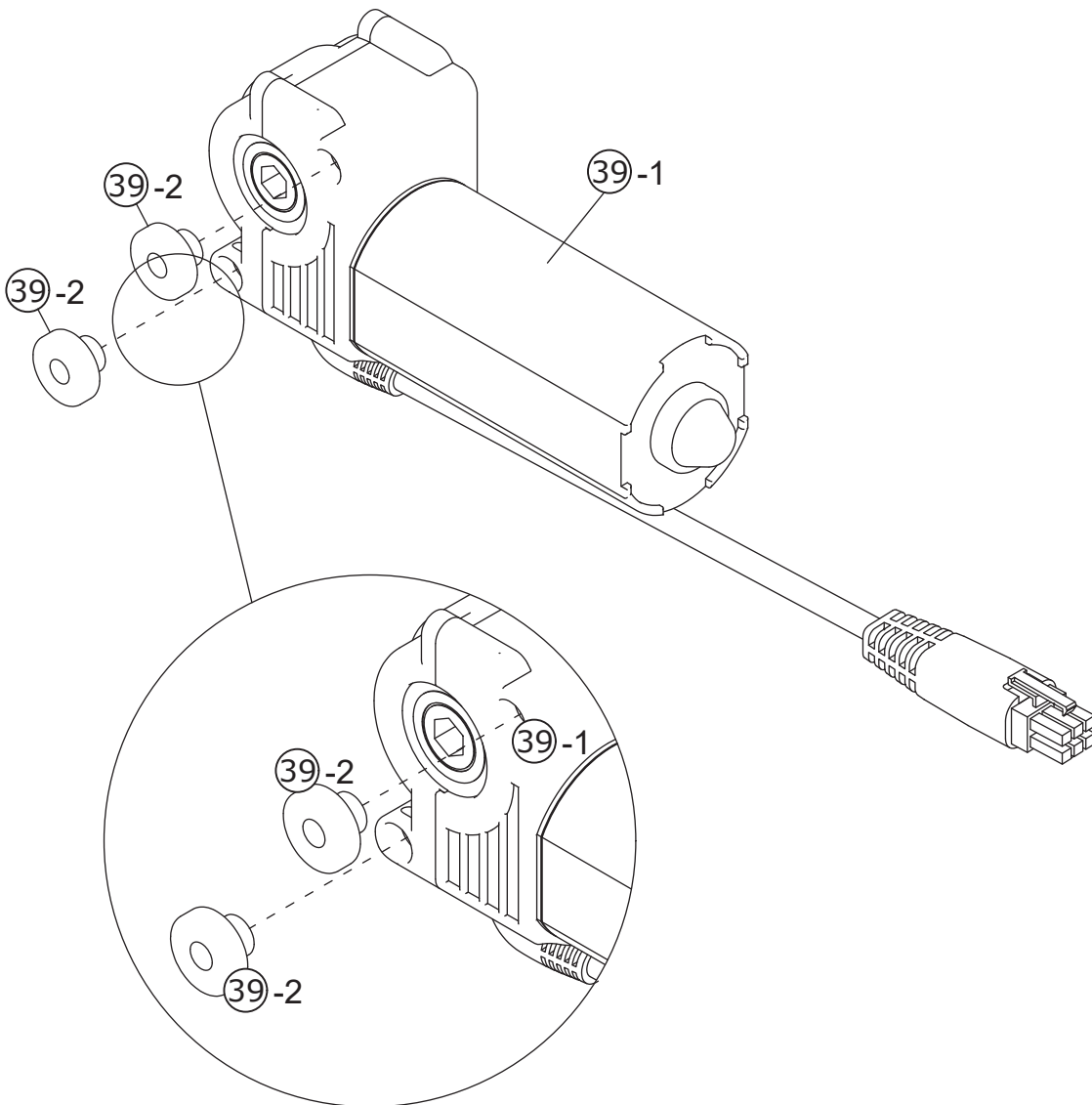

22

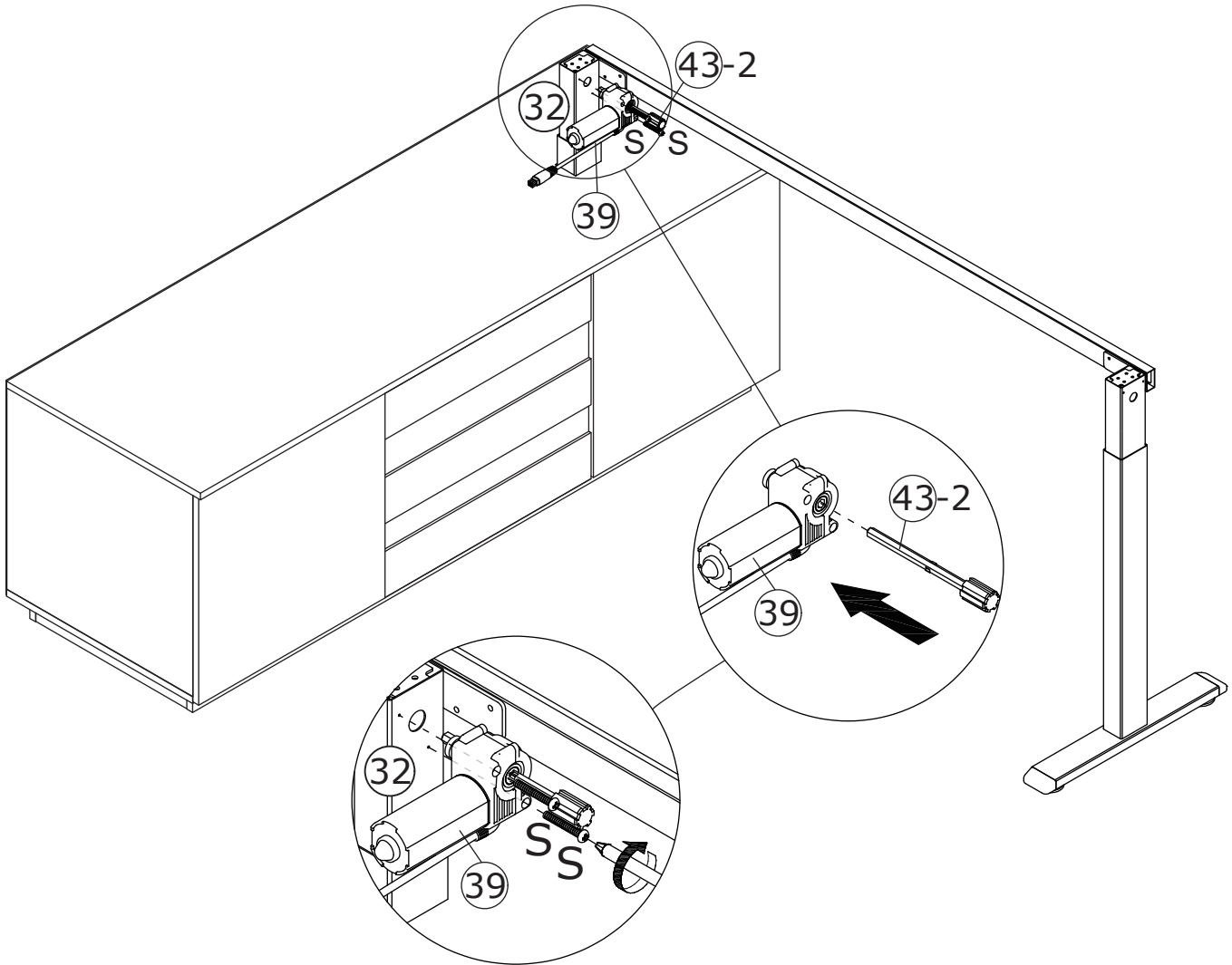
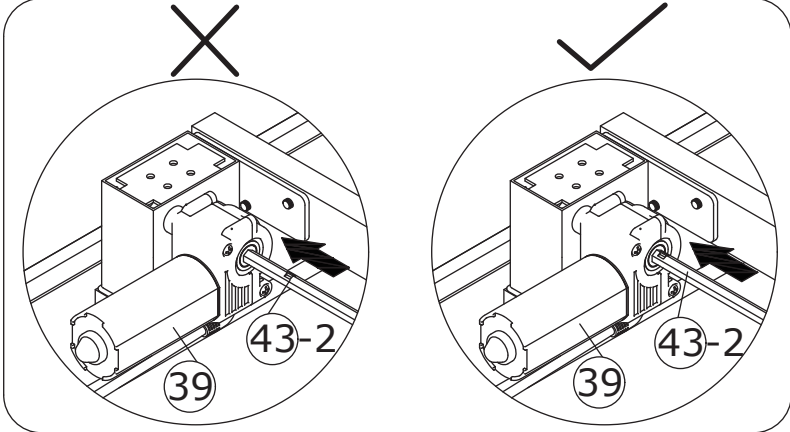
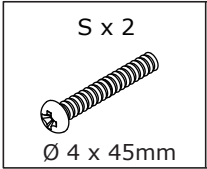

As shown in the figure, pass Component (43-2) through Motor (39), then install Motor (39) onto Steel Frame 32 using Screws (S).

23

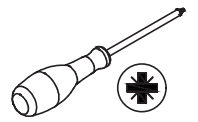

Loosen the knob on Component (43-1), extend Component (43-1) into Steel Frame 33, and insert it to the depth as shown in the figure.

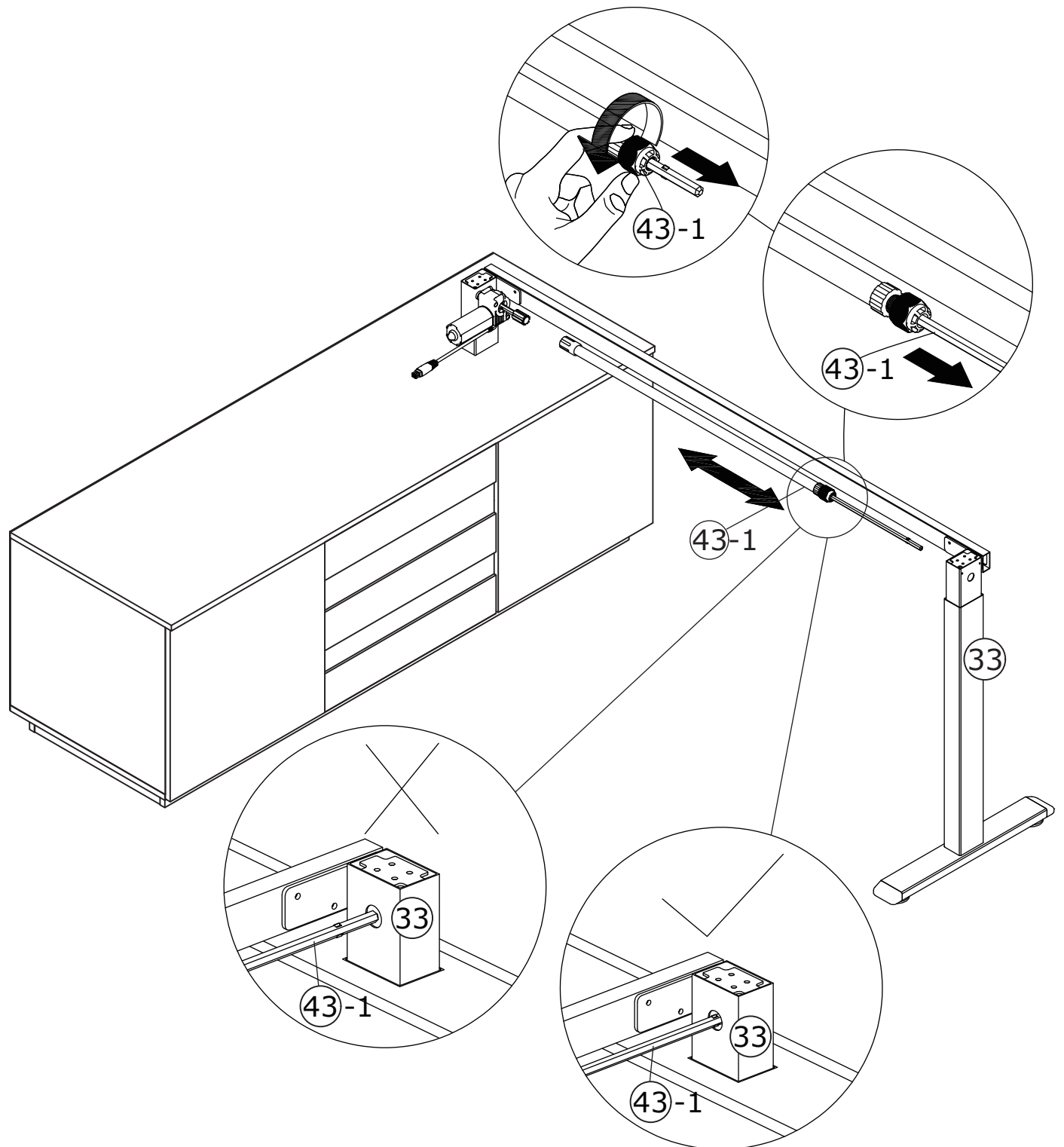

24

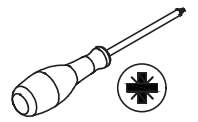

As shown in the figure, insert component (43-1) into component (43-2), then tighten the knob on component (43-1) to secure it in place.

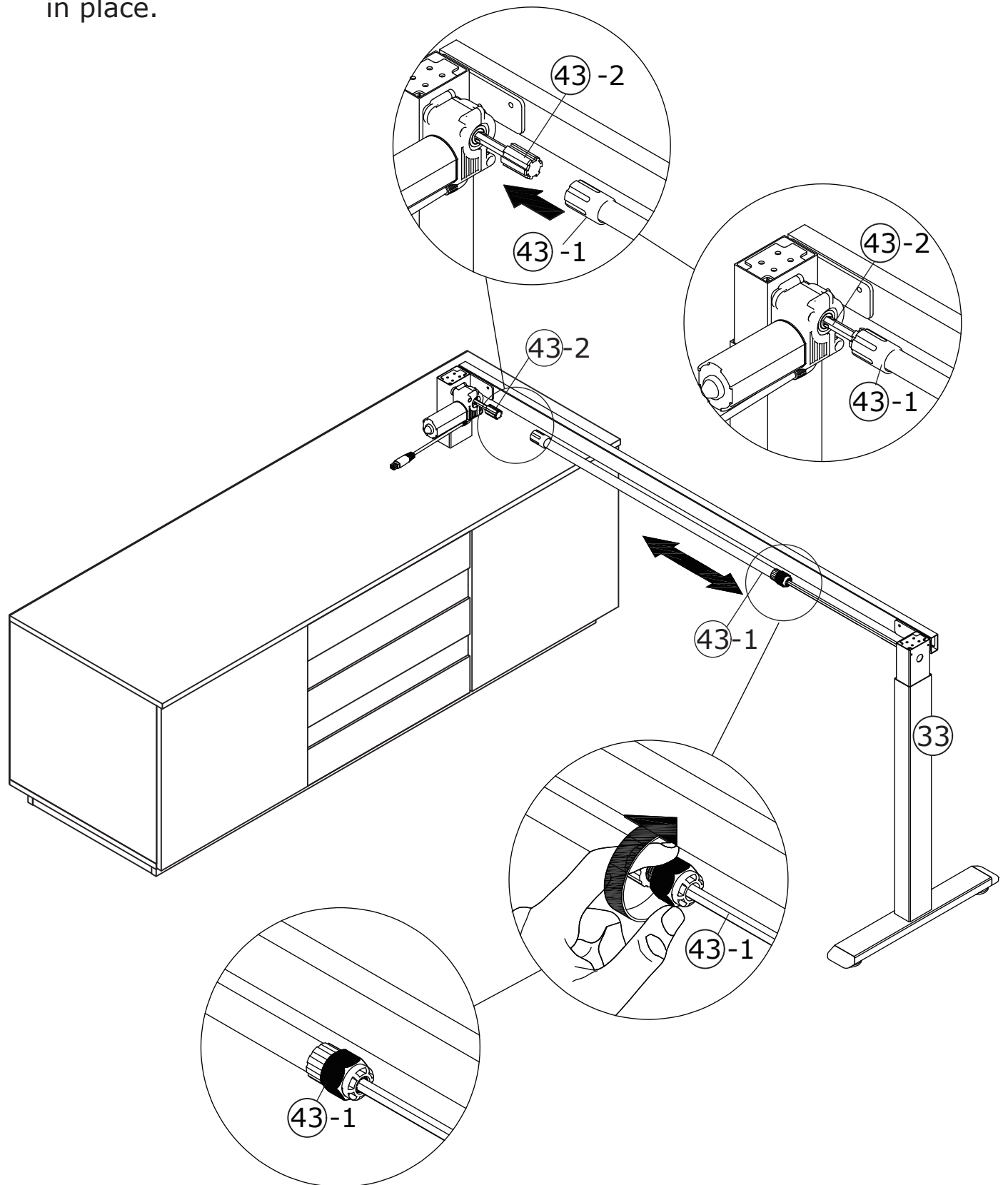

25

As shown in the figure, connect the power supply.

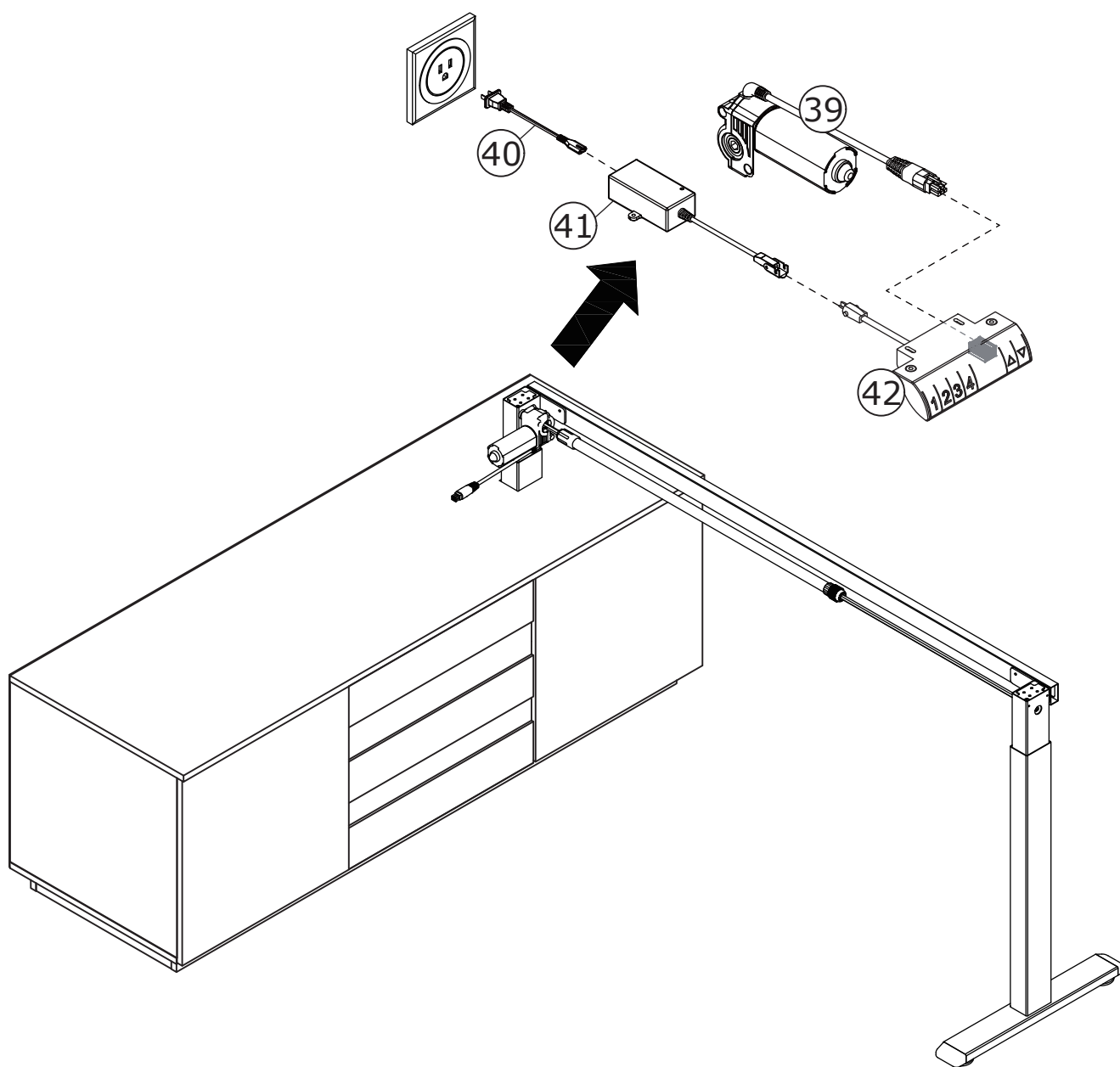

26



As shown in the figure, raise the steel frame to the highest position.

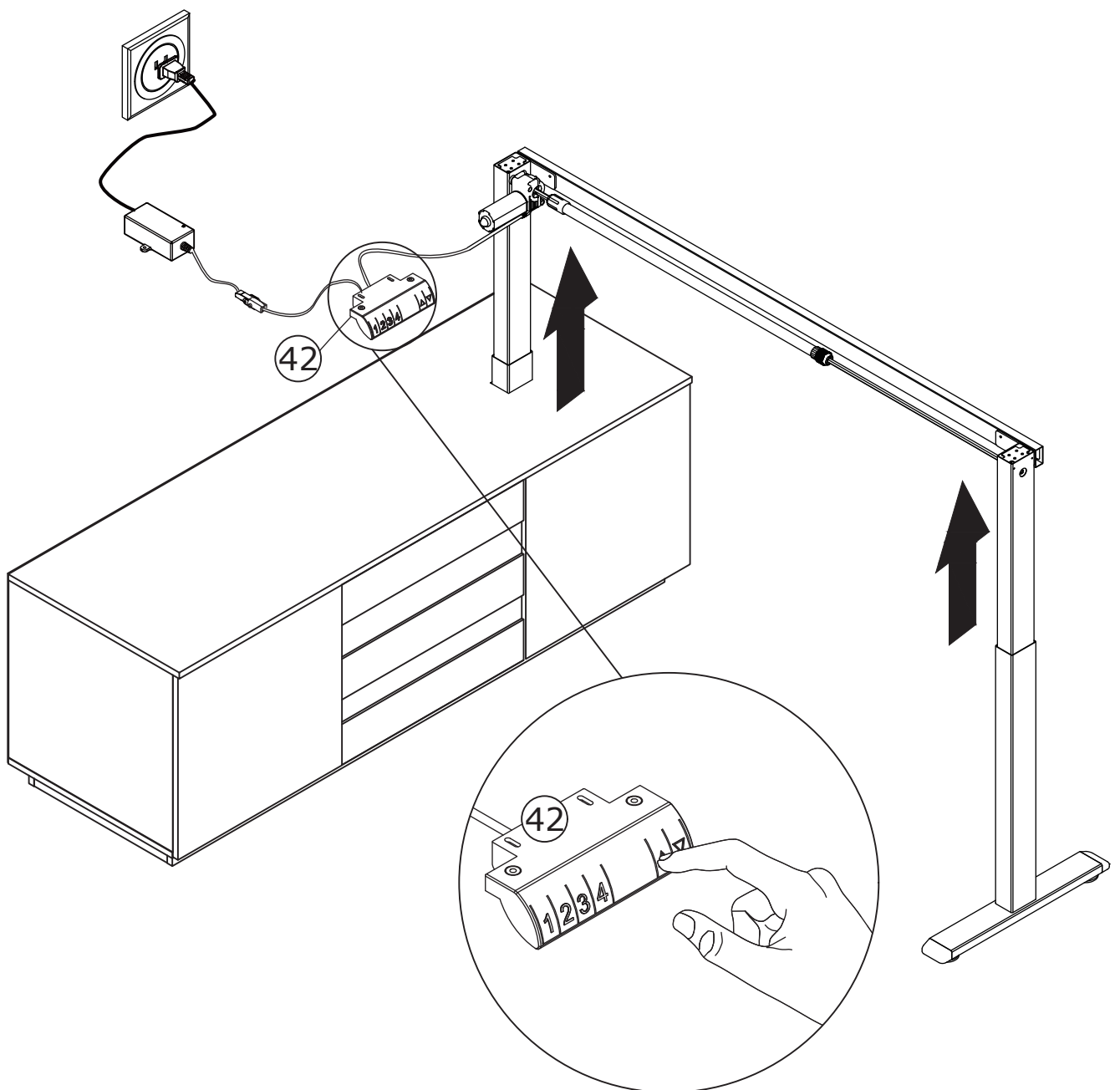

27

<p>R x 4</p>  <p>Ø 6 x 20mm</p>	<p>45 x 1</p>  <p>#4</p>	
--	---	--

As shown in the figure, connect Steel Frame 37 to Steel Frame 38 using Screws (R).

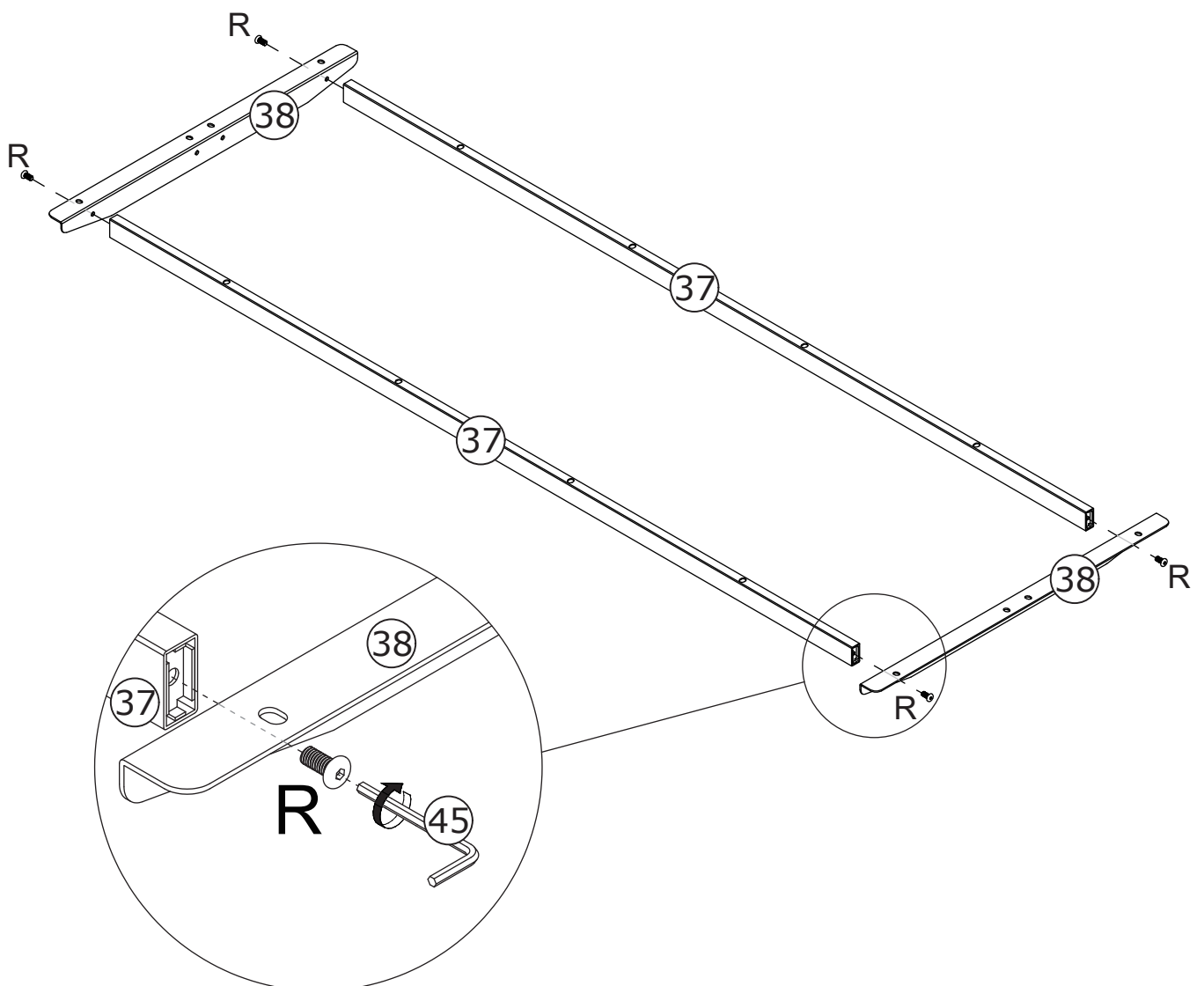

28

<p>N x 4</p>  <p>Ø 6 x 8 mm</p>	<p>45 x 1</p>  <p>#4</p>	
--	---	--

As shown in the figure, connect Steel Frame 38 to Steel Frame 32 and Steel Frame 33 using Screws (N).

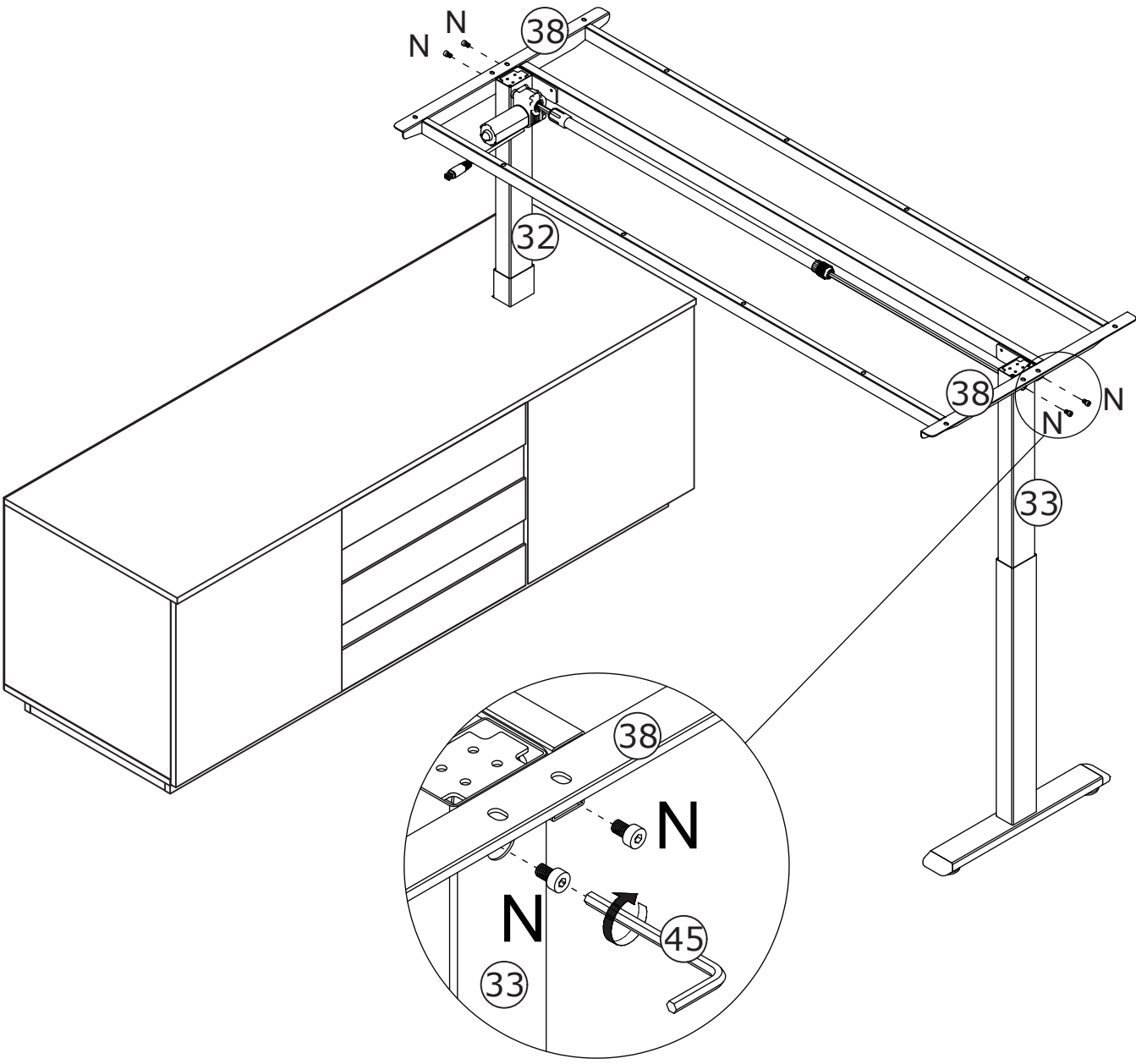



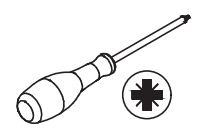
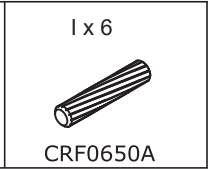
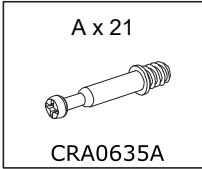

29

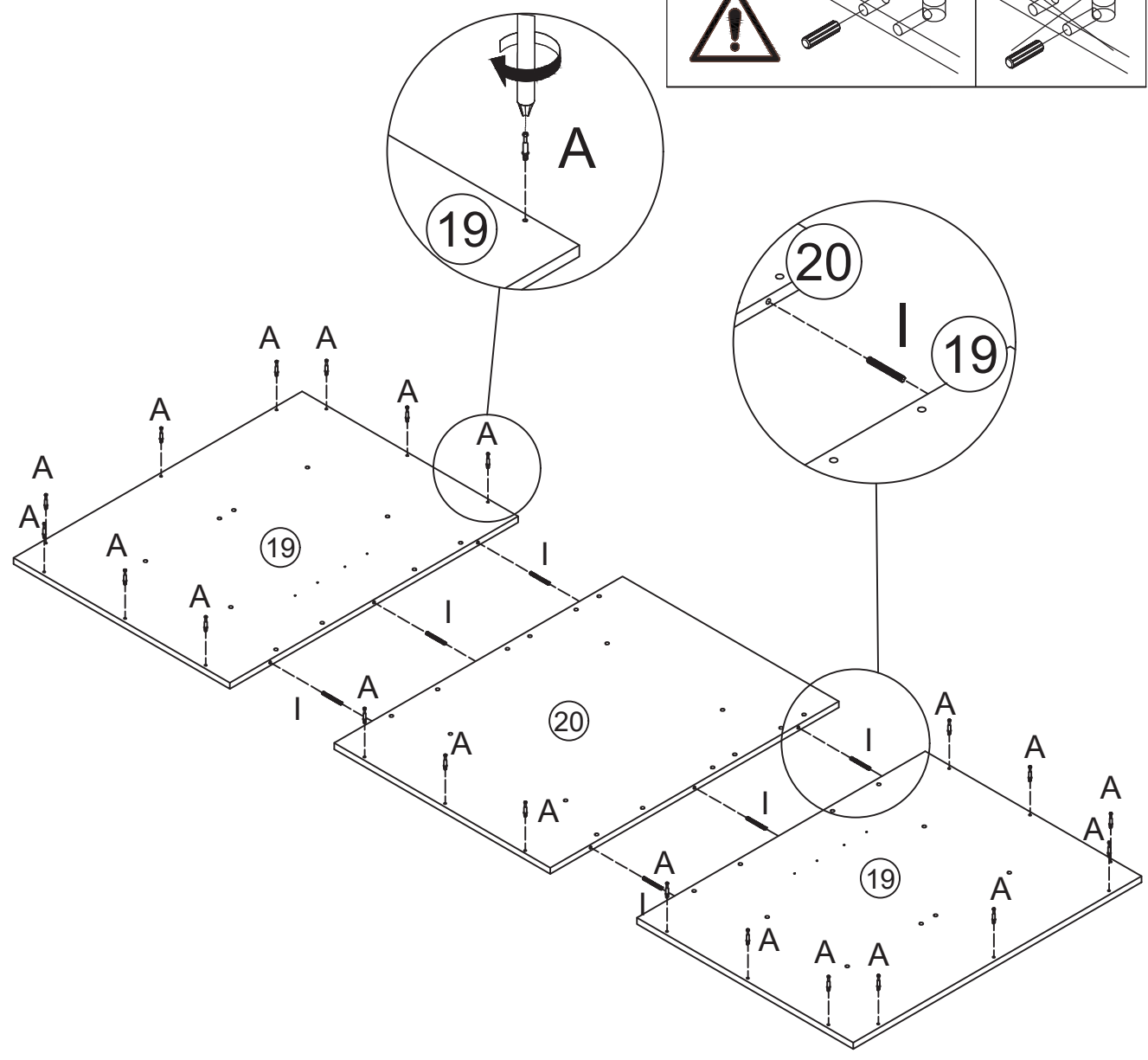
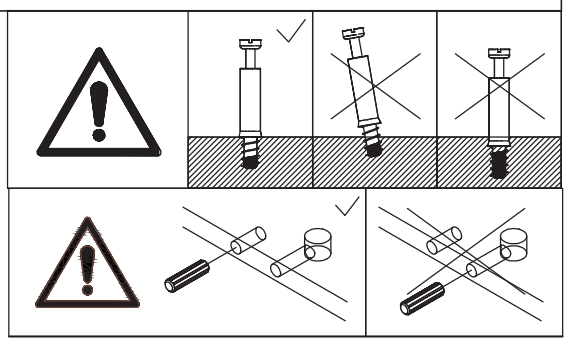

Screw eccentric rod (A) into board 19 and 20 at first.  
Connect board 19 and board 20 with wooden dowel (I) as shown.

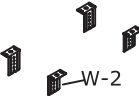

30

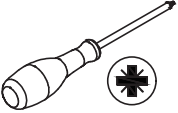
K x 8 	Q x 16 Ø 6 x 12mm 	V x 4 CRG0612A 	W x 1 W-2 	45 x 1 #4 	
--	---	--	--	---	---

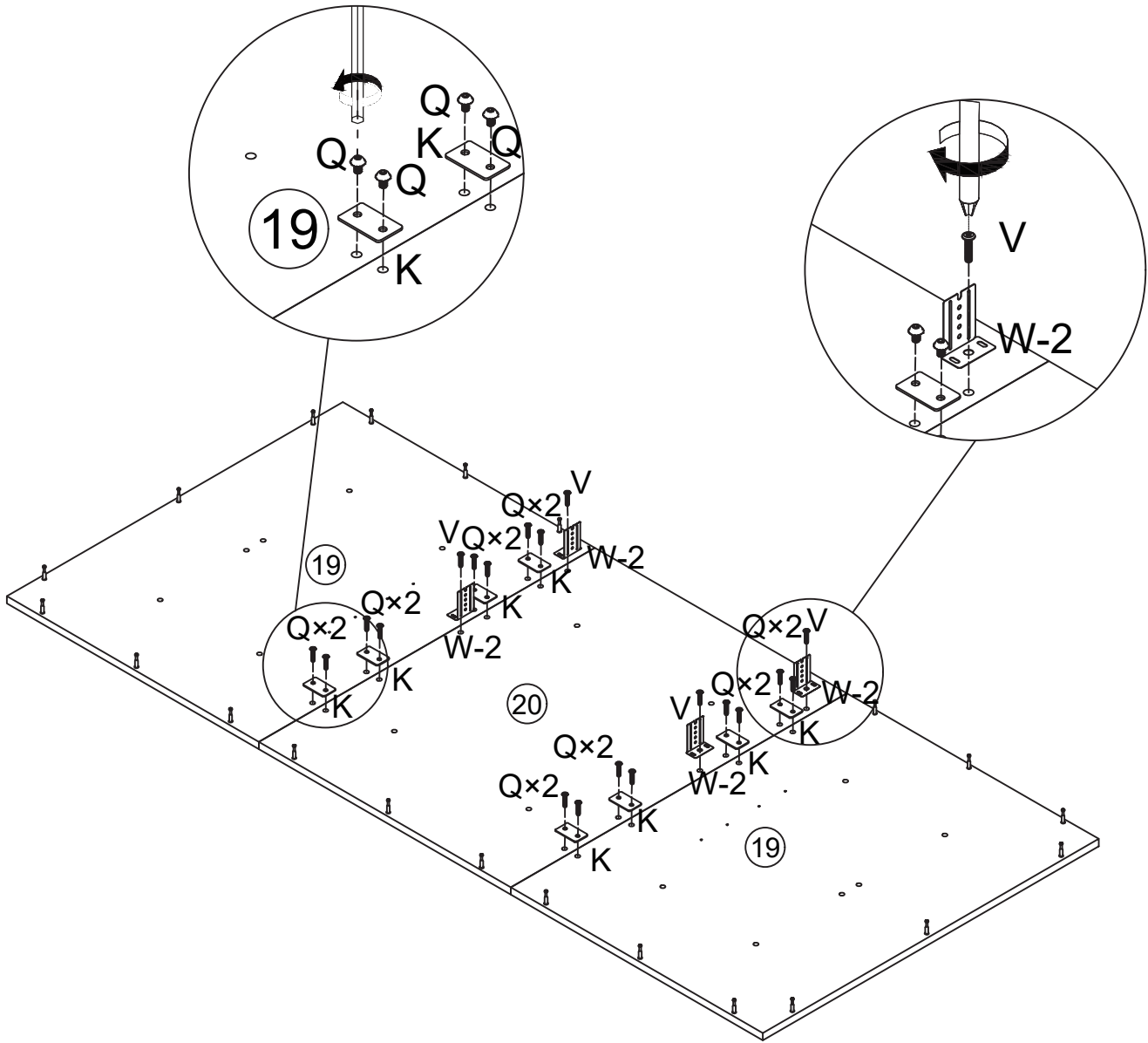

As shown in the figure, fasten Component (K) to Panel 19 and Panel 20 using Screws (Q), and secure Component (W-2) to Panel 19 with Screws (V).

31

A x 8  
CRA0635A

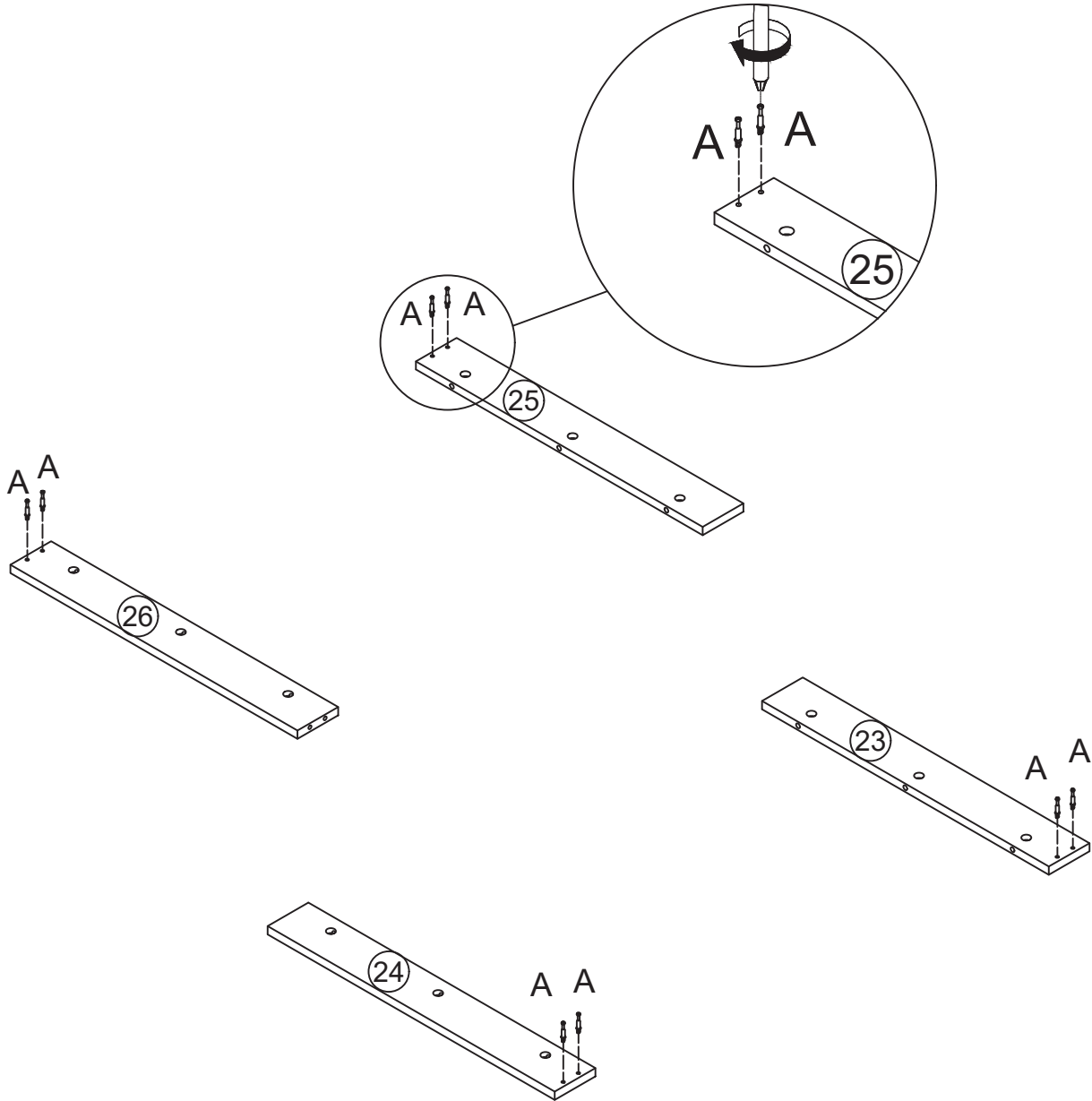
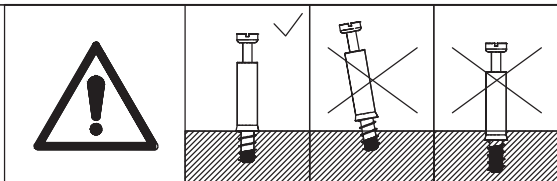
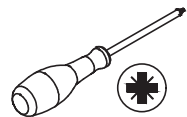

Screw eccentric rod (A) into board 23, 24, 25 and 26 at first.

32

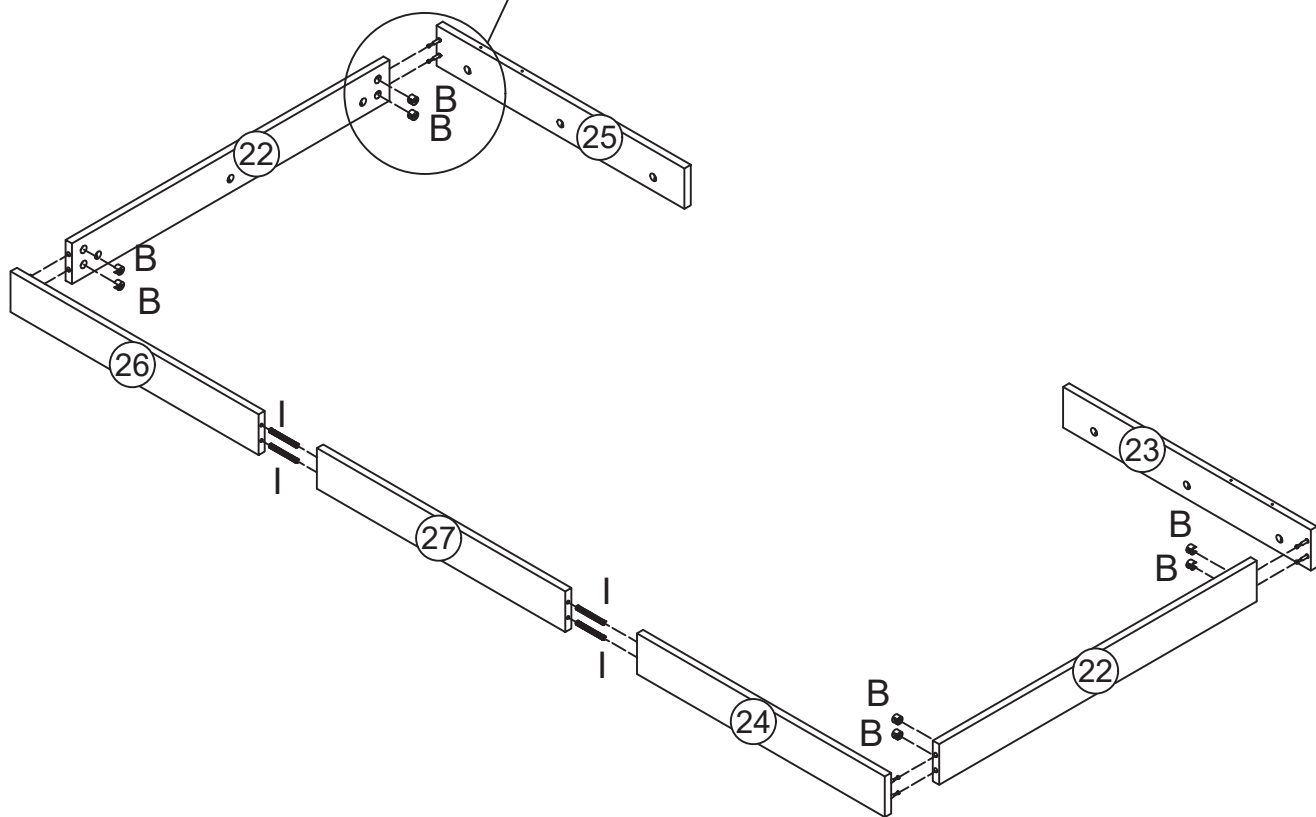
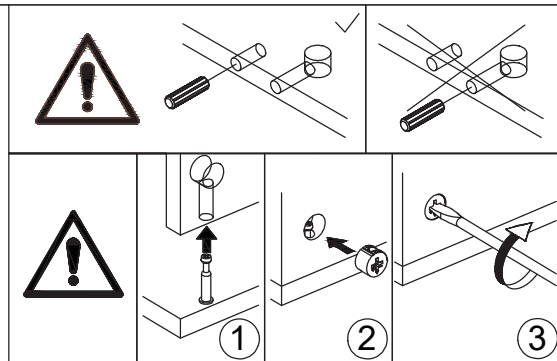
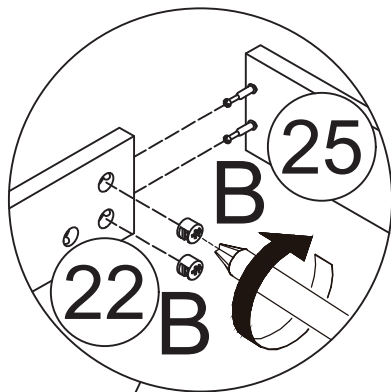

Connect board 26, 27 and 24 with wooden dowel (I) firstly.  
Connect board 25, 22 and 26, add cam lock(B) into and turn clockwise to tighten as shown.  
Connect board 23, 22 and 24, add cam lock(B) into and turn clockwise to tighten as shown.

33

B x 21  
CRB1595A

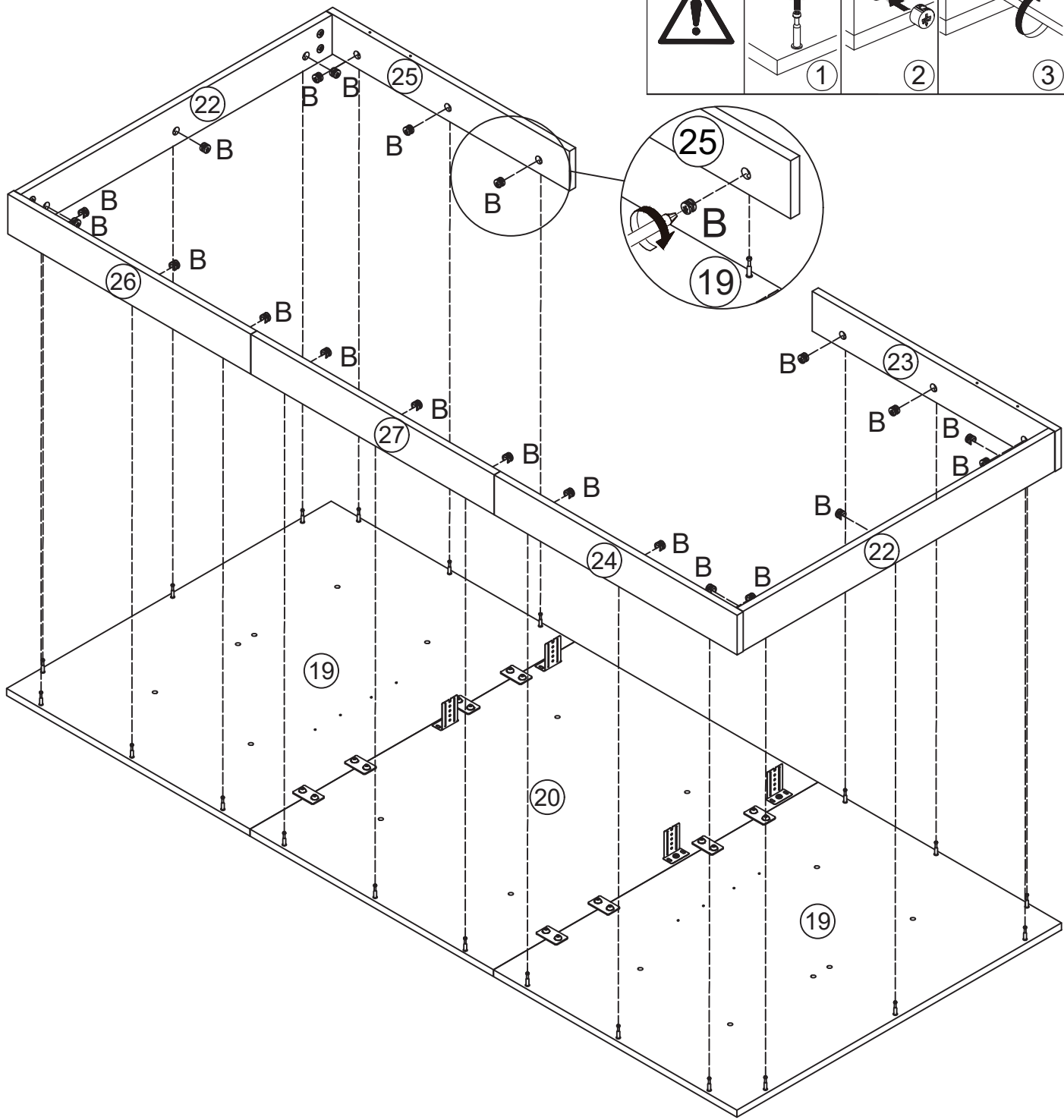
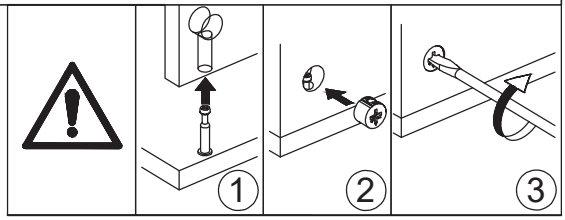
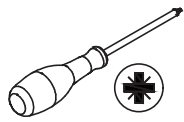

Assemble the components in step 29 and step 31, add cam lock(B) into and turn clockwise to tighten as shown.

34

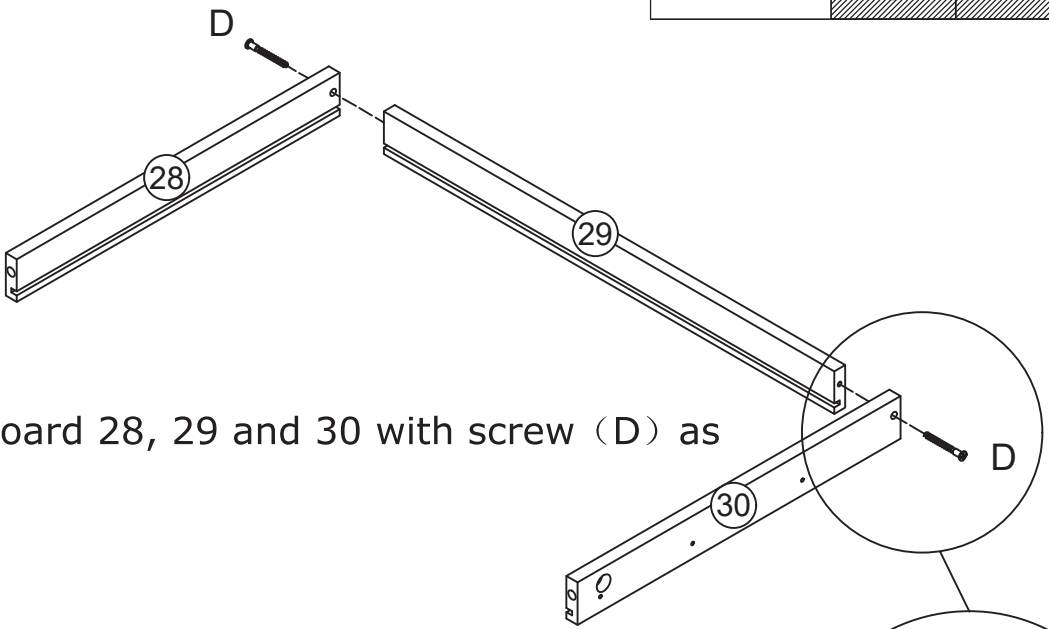
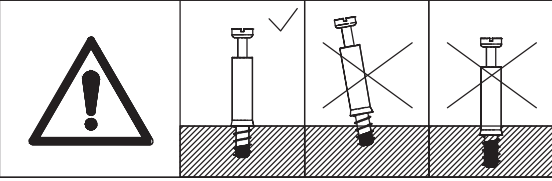

Connect board 28, 29 and 30 with screw (D) as shown.

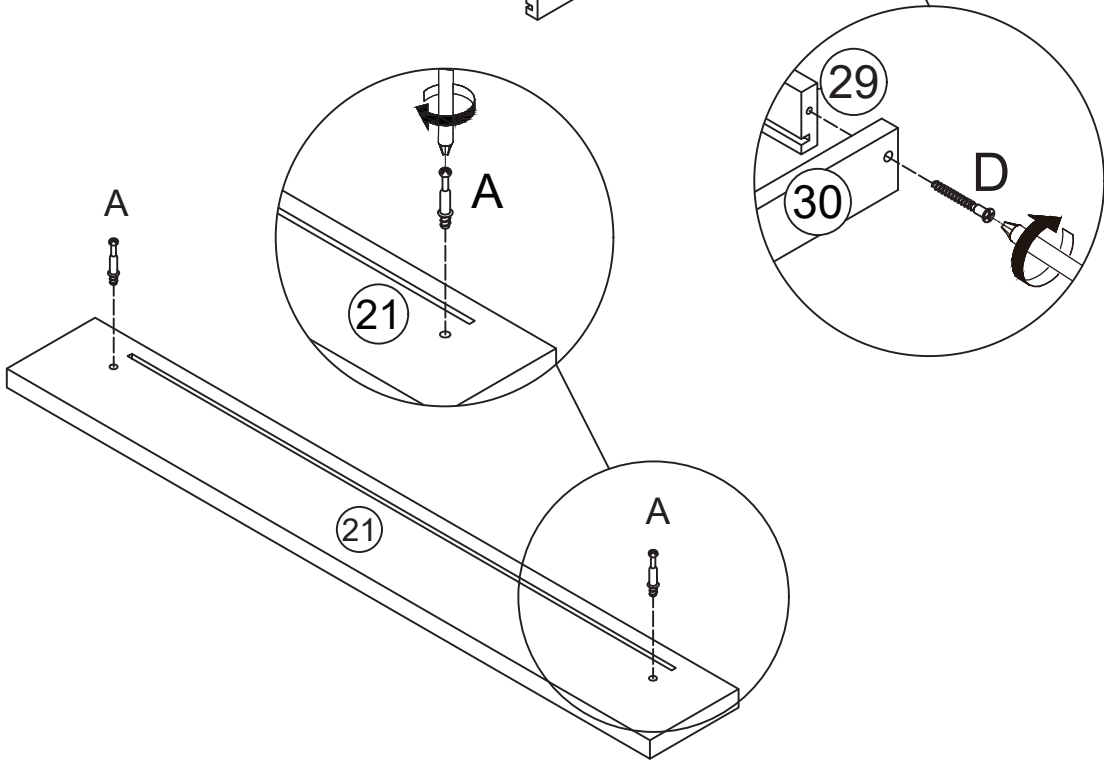

Screw eccentric rod (A) into board 21 at first.

35

B x 2  
CRB1595A

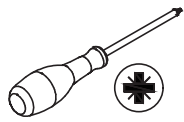

Slide board 31 into grooves as shown.

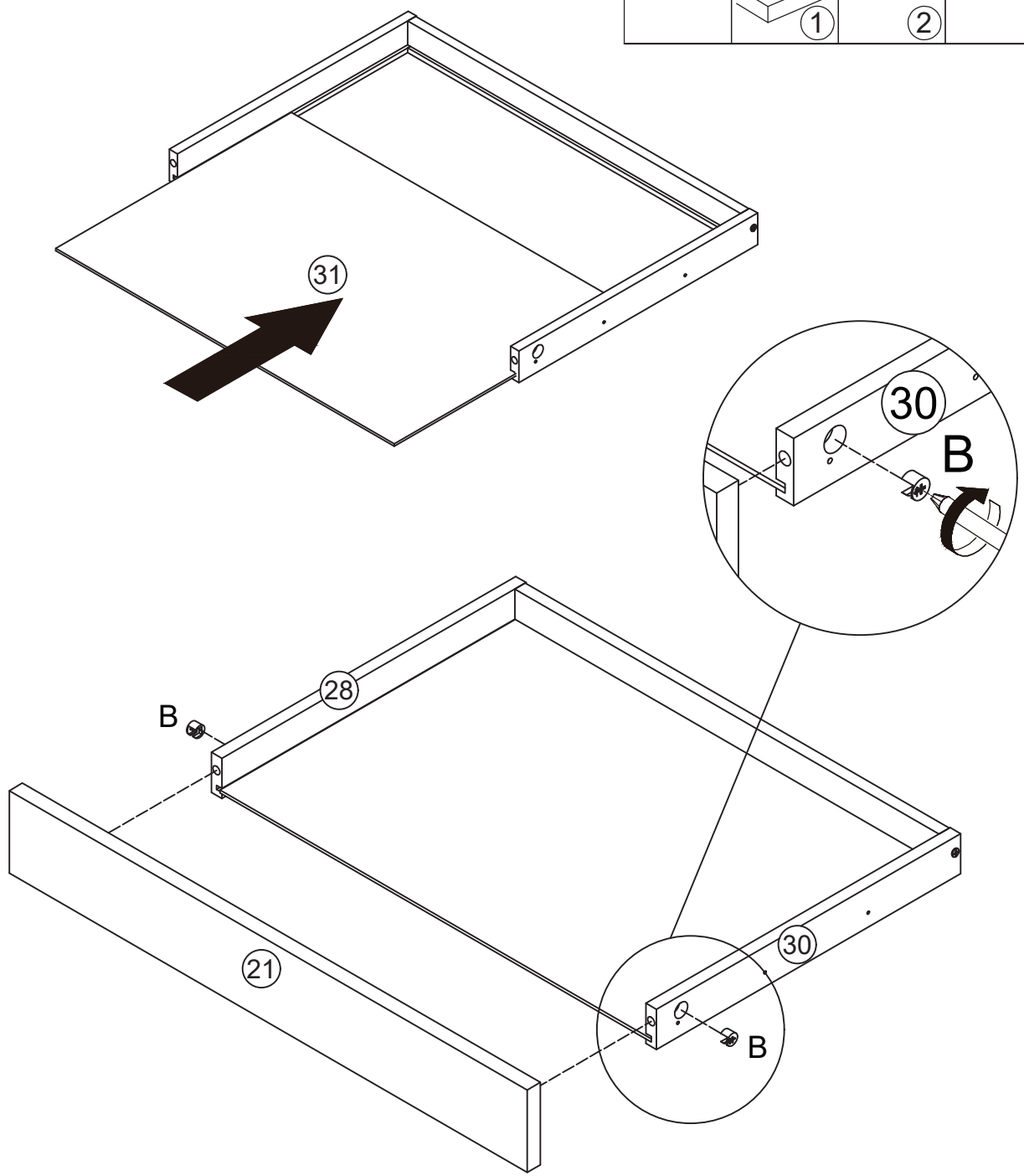
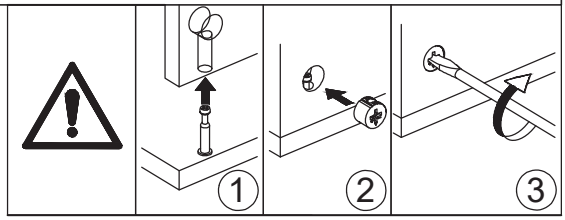

Connect board 21 to the drawer, add cam lock(B) into and turn clockwise to tighten as shown.



36

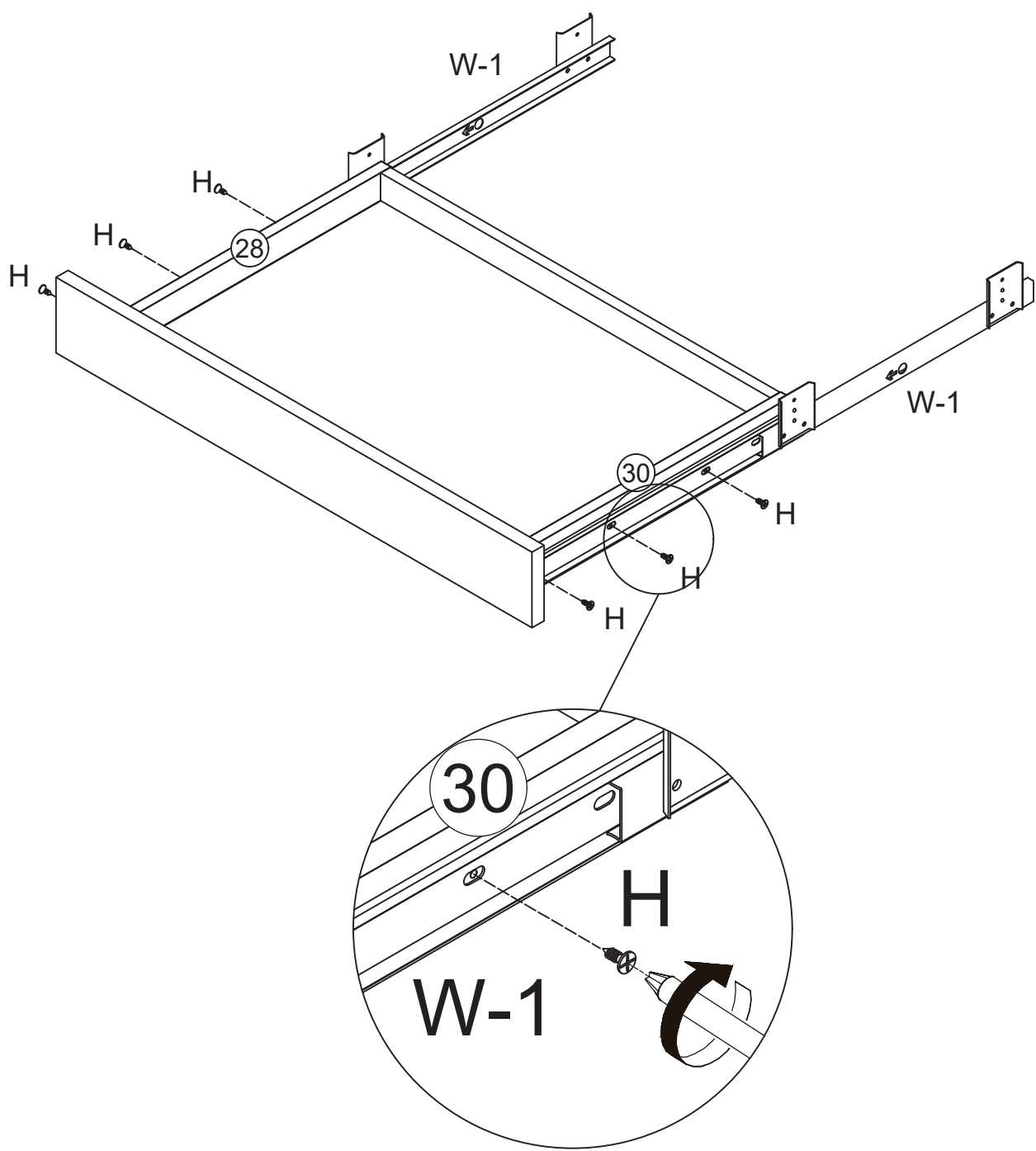

Fix rail (W-1) to board 28 and board 30 with screw (H) as shown.



37

<p>M x 8</p>  <p>Ø 6 x 40mm</p>	<p>Q x 8</p>  <p>Ø 6 x 12mm</p>	<p>45 x 1</p>  <p>#4</p>	
--	--	---	--

As shown in the figure, fasten the mounting unit from Step 32 to the steel frame using Screws (Q) and (M).

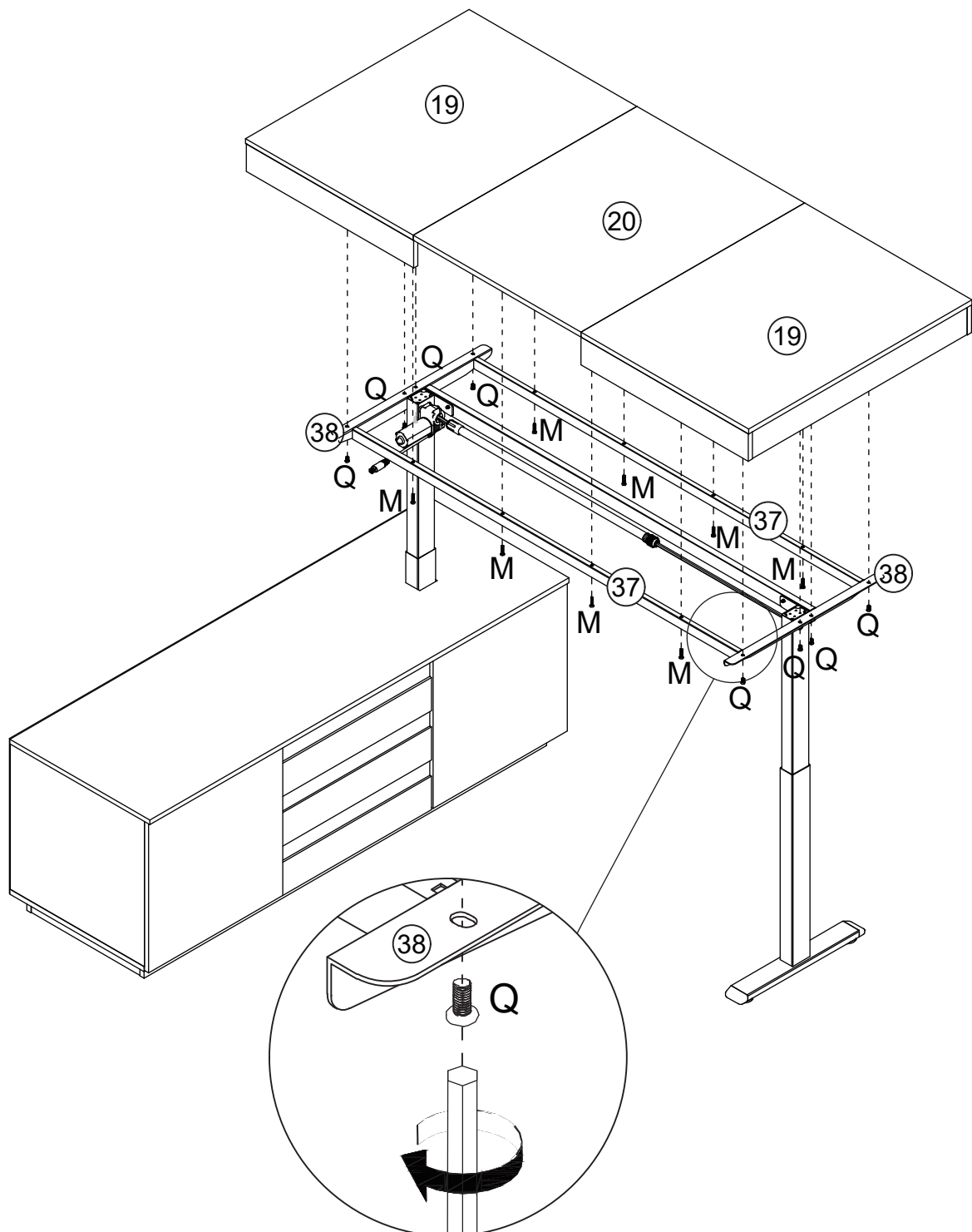

38



Fix rail (W-1) to the table with screw (W-3) as shown.

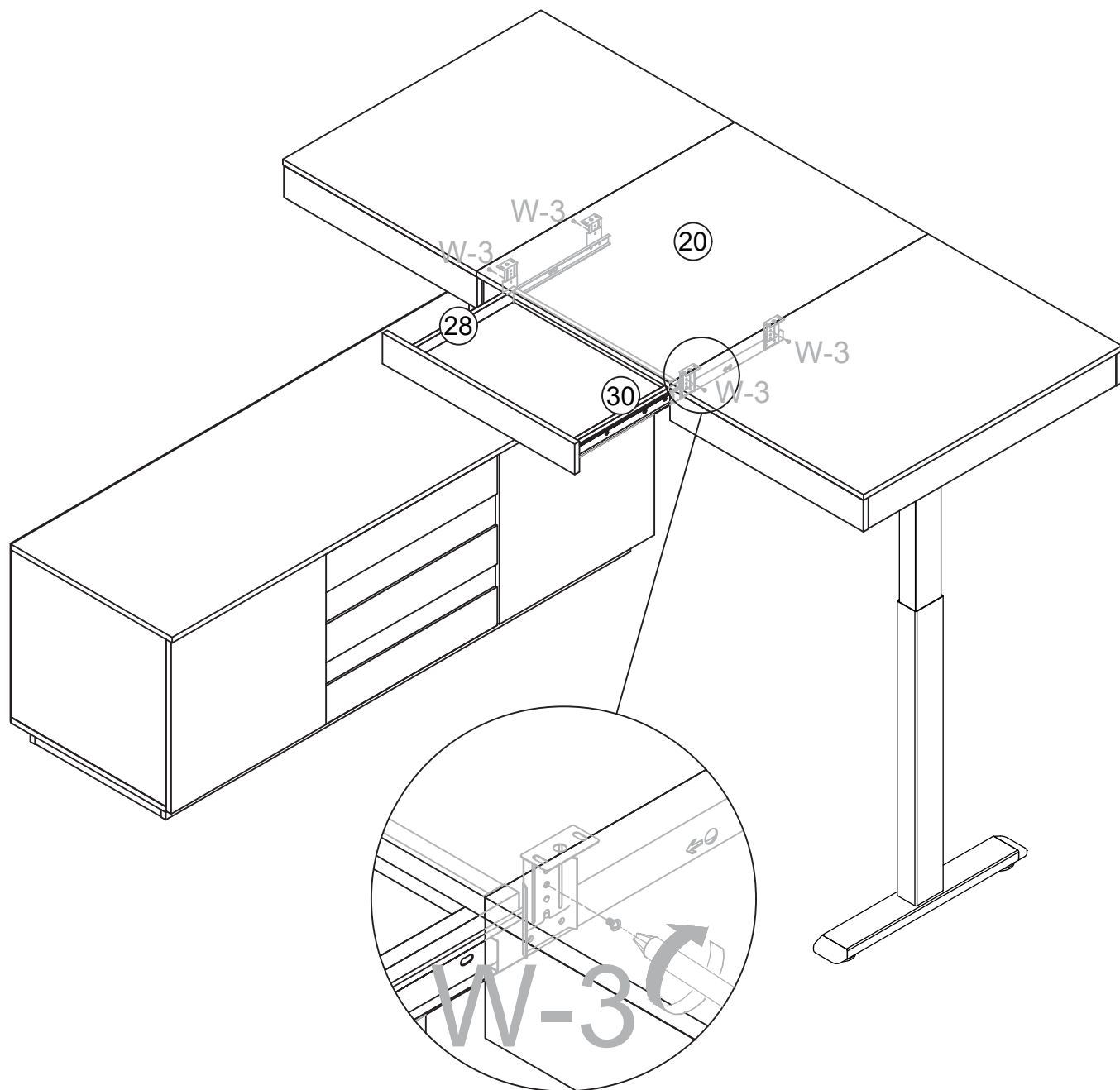

39

F x 4



CRD3514A

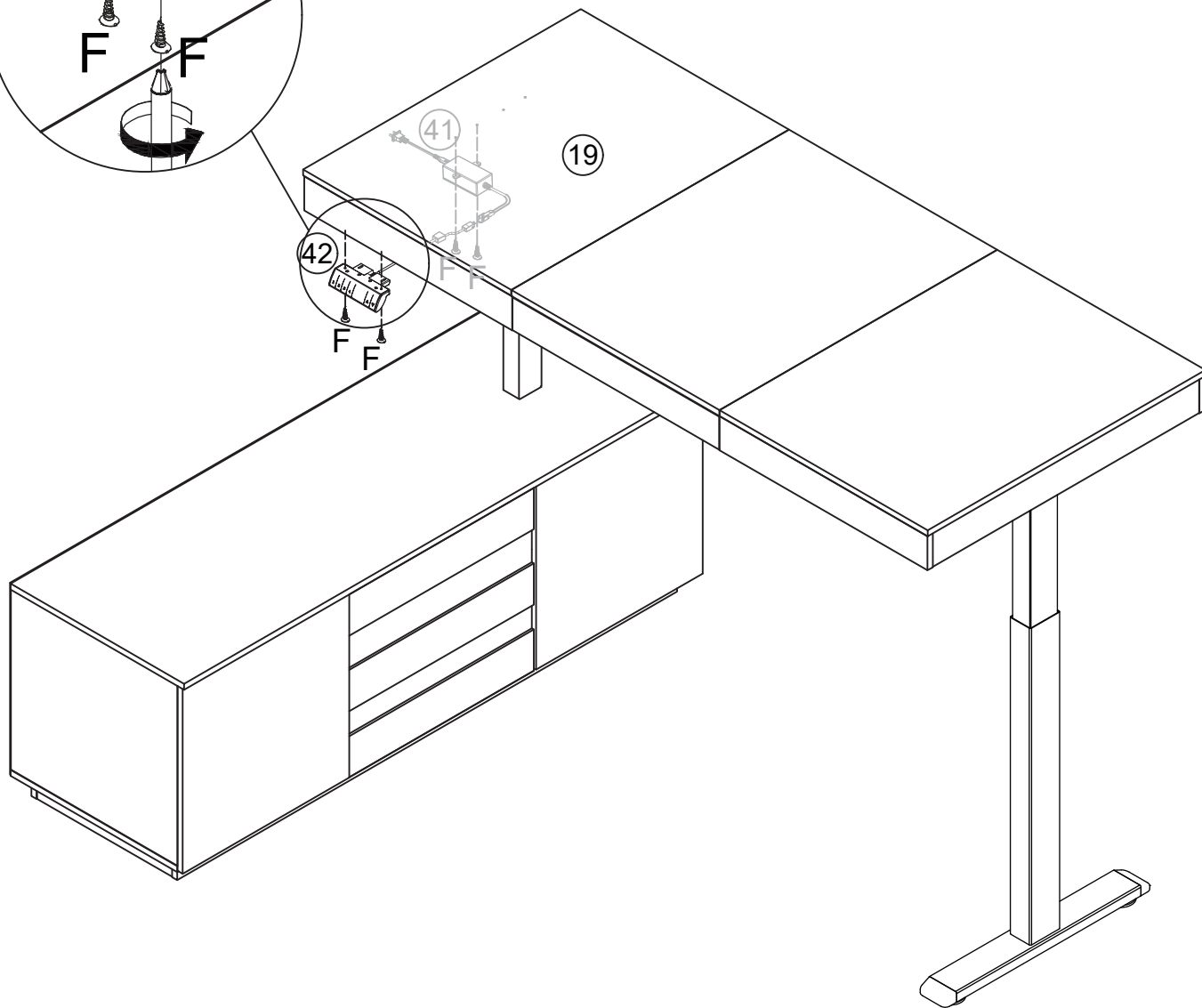
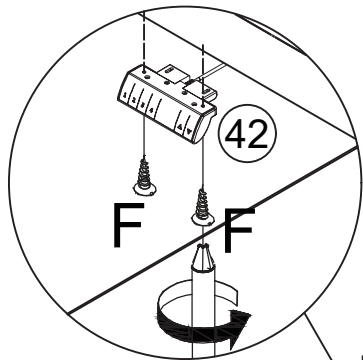
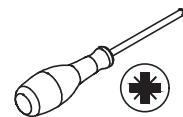

As shown in the figure, fasten Plug 41 and Control Panel 42 to Panel 19 using Screws (F).

40

F x 8  
CRD3514A

P x 4

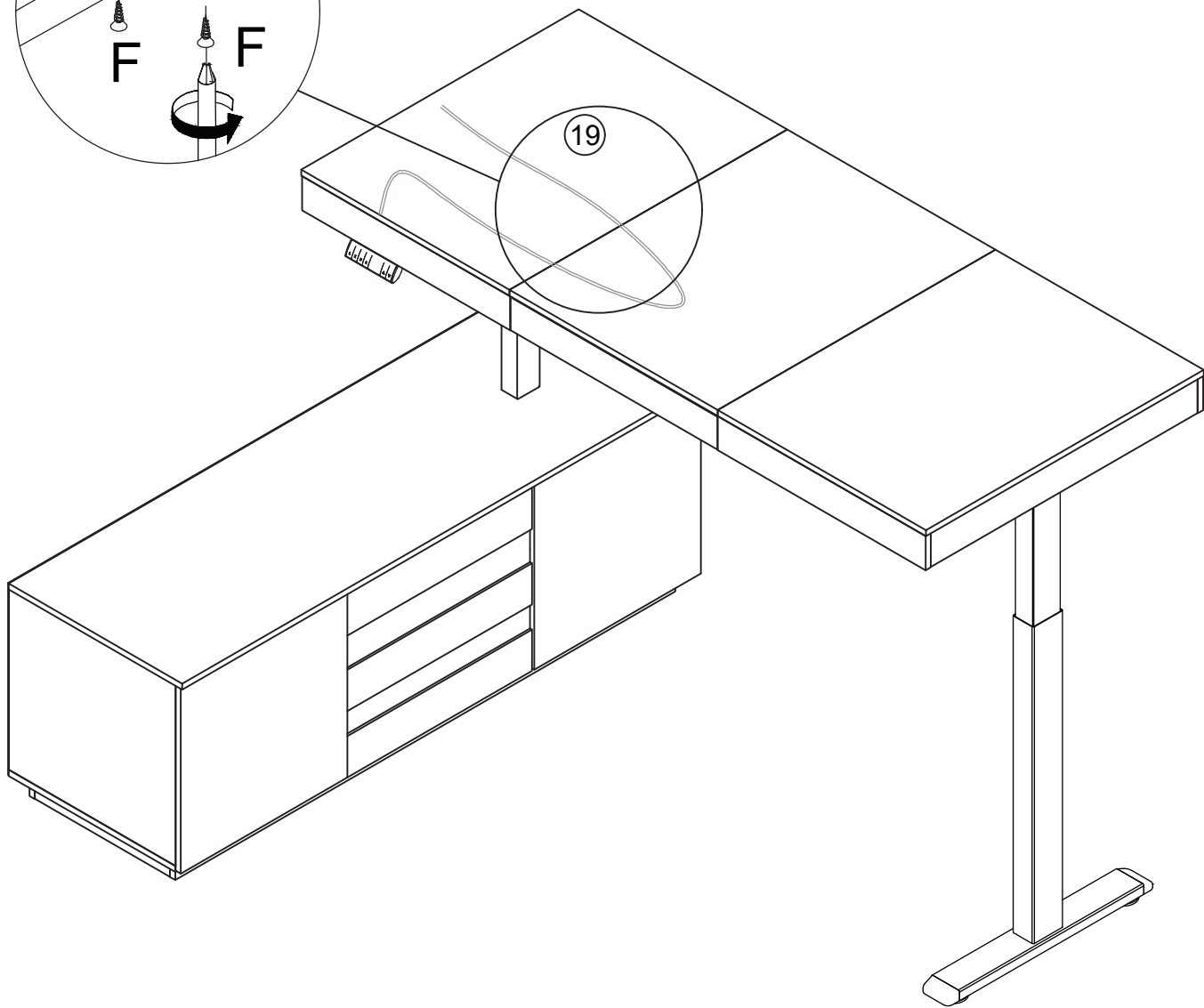
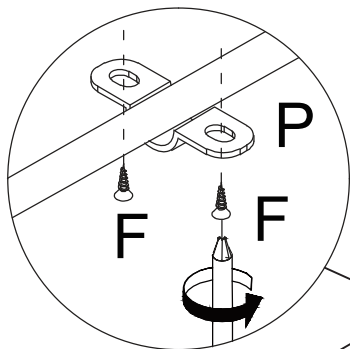
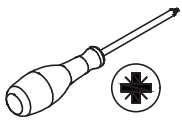

Settle wire with part (P) ,then fix part (P) to board 19 with screw (F) as shown.

# WARRANTY

## WARRANTY CLAIMS

- There is a 30-day warranty for broken furniture or any other problems that do not work properly. The warranty will start from the date of purchase which must be verified by proof of purchase.
- Before making a claim, we may be able to answer your query, simply call us. Please leave your purchase order number, along with some details of the problem, if you want a replacement part. We will arrange within 48 hours. If there is out of stock, we will reply with a shipping date.
- The product must be used in accordance with the instructions provided. For health reasons.
- For other reasons, if the furniture needs to be returned, it must be cleaned and dried and operated within 30 days of receipt.

## Type of Warranty Claim

- Failure to follow the furniture instructions will invalidate the warranty. Attention please.
- Does not include damage during installation, but includes damage during transportation.

## Scope of responsibility

- Shall not bear any responsibility for misuse or user damage and / or loss of parts during the installation of furniture.
- After using, the damage and scratches of the furniture are not covered by the warranty.

## The Warranty Relates to All Bought in The Us and Covers The Following Areas

- Sheet parts: 1 month from the date of purchase.
- Electrical parts: 1 month from the date of purchase.

# RETURNS

## **CHANGED YOUR MIND AND NEED TO RETURN YOU ITEM?**

### **PLEASE FOLLOW THE BELOW INSTRUCTIONS:**

- If you have purchased and have simply changed your mind, follow the retailer's instructions for returns.

### **DEFECTIVE ITEMS**

- If your item is defective in any way, i.e. it doesn't work but you can't identify why, in the first instance, please call us.

### **DAMAGED ITEMS**

- If you receive an order with obvious shipping damage from the retailer, then we suggest the delivery is refused. If the delivery has been accepted and then shipping damage is found, please follow the specific instructions advised by the retailer.  
In all circumstances please save all packaging material and paperwork for the order. Please be aware that if you dispose of packaging material or attempt to return the merchandise without contacting the fulfiller, you jeopardise your chances of making a claim, and you may not receive a credit for the return.