

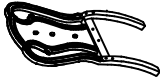

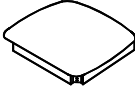





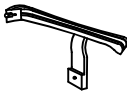

# ASSEMBLY INSTRUCTIONS

Dimensions : 17 1/8"W x 20 1/2"D x 42 1/8"H

Item No : F1826/ F1828

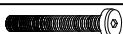
Description : ARM CHAIR

No	LIST OF PARTS	Q'TY
1	Chair Back 	1pc
2	Seat Cushion 	1pc
3	Front Leg 	2pcs
4	Arm (R&L) 	2pcs

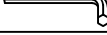
No	LIST OF HARDWARE	Q'TY
A	Long Bolt  Ø1/4" x 38 mm	4pcs
B	Lock Washer  Ø1/4" x 10D x 1.1mm	4pcs
C	Flat Washer  Ø1/4" x 22D x 2mm	4pcs
D	Medium Bolt  Ø5/16" x 63.5mm	4pcs
E	Short Bolt  Ø5/16" x 83mm	4pcs
F	Lock Washer  Ø5/16" x 10D x 1.1mm	8pcs
G	Flat Washer  Ø5/16" x 22D x 2mm	8pcs
H	Allen Wrench  4 mm	1pc
I	Screw  Ø8x 45mm	2pcs

## STEP 1

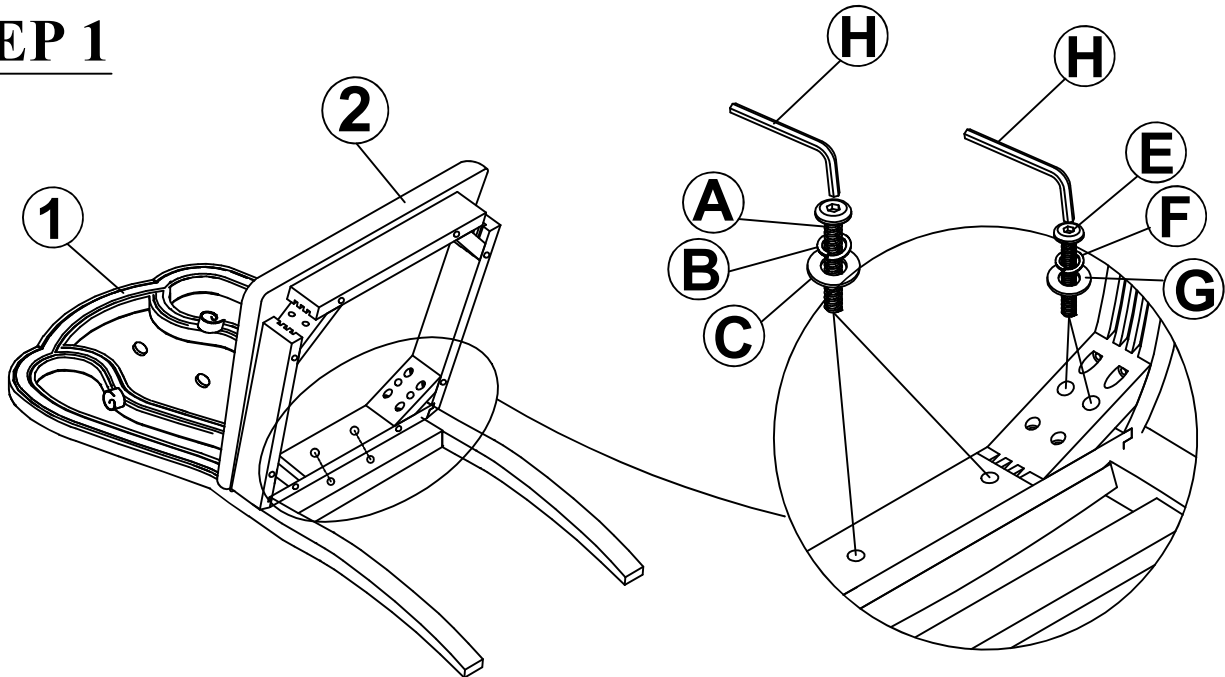

## STEP 2

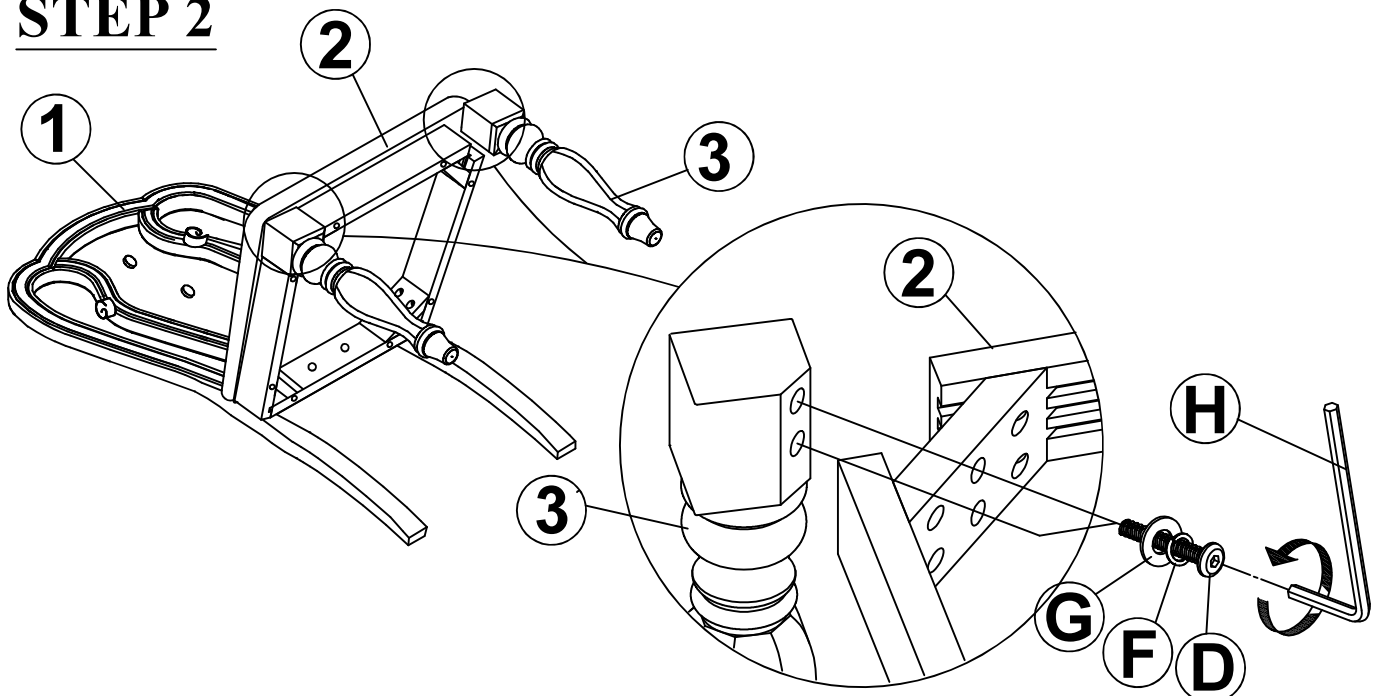

### STEP 3

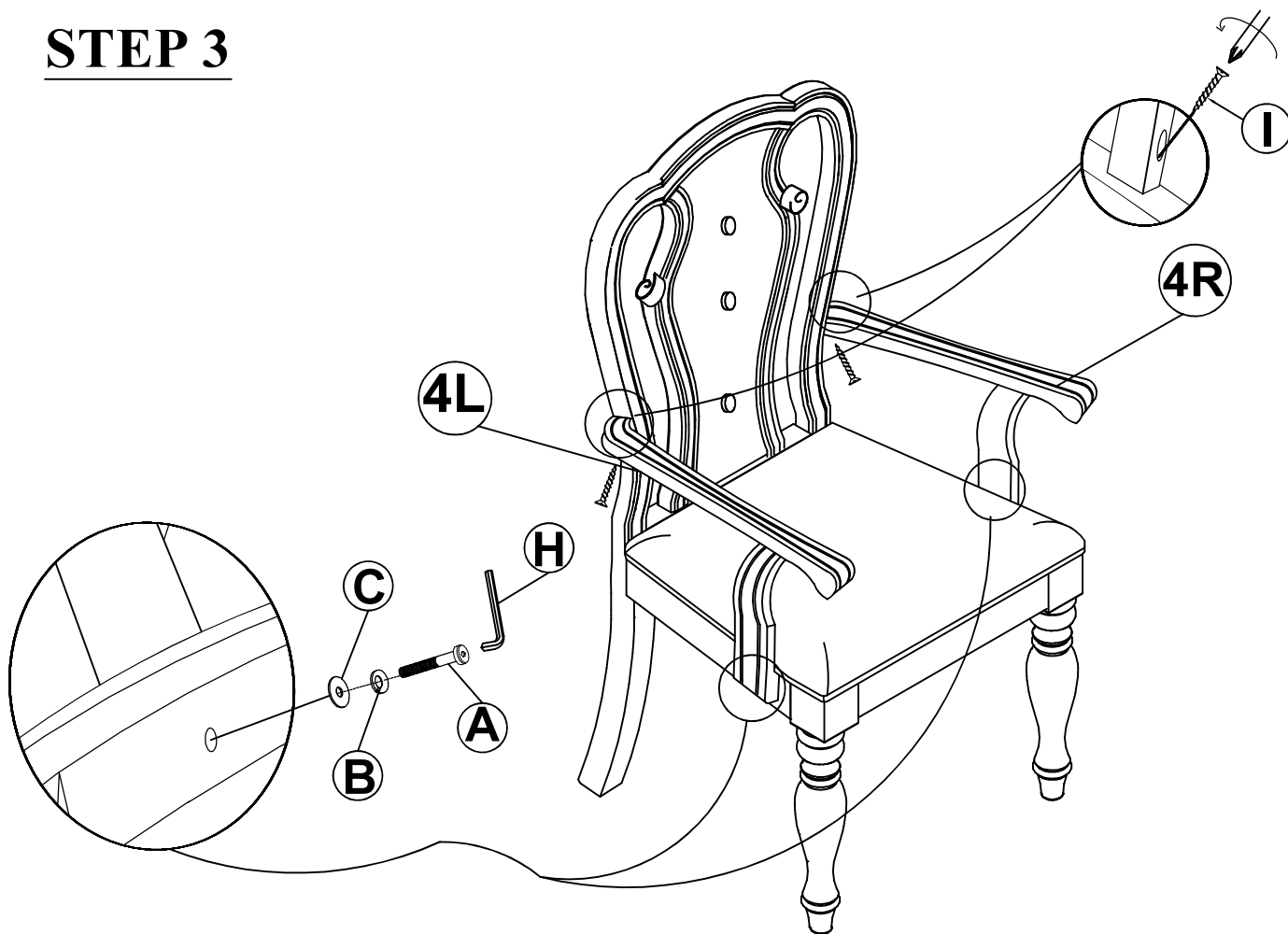

### STEP 4

