

ZDM-PA018

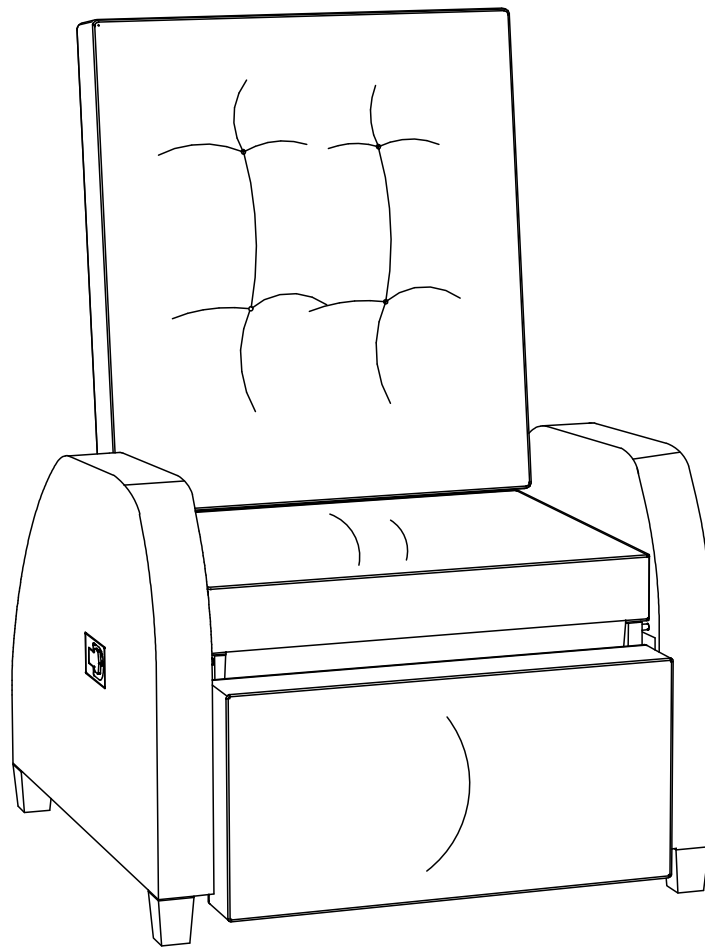

INSTRUCTION MANUAL
MANUAL DE INSTRUCCIONES

IMPORTANT

Follow the instructions for the assembly, daily care and after-sales service!

1. Insulate the furniture:

Rattan furniture will go soft because of the heat. To guarantee and extend its service life, it should be put at a place away from the heat.

2. Keep away from the direct sunlight:

Strong sunlight will discolorate the rattan and shorten its service life. When in use, it should be kept away from the direct sunlight.

3. Avoid contact with water:

Rattan furniture usually has a metal frame for the solidness and sturdiness, but it will get oxidized and corroded because of a contact with the water. So it should avoid the contact with water when being used.

4. Clean and maintain the furniture:

Use a feather duster to clean the dust and dirt on it. For stubborn stain, use the wet towel to wipe it off. Wax the rattan to prevent it from discoloration and keep good-looking.

5. Do not allow light source to focus on it:

Glasses, mirrors and other items that are easy to gather the light source should not be put at a place where they can project the light source to the furniture.



Note: It's normal for the sponge to appear yellow after taking in air.

ASSEMBLY INSTRUCTIONS

Carefully unpack all the components and verify that all the necessary parts are included as listed in the packaging.

Identify each component and refer to the provided assembly diagram or step-by-step instructions.

Assemble the furniture in the order specified to ensure proper alignment and fit.

Use the provided tools or recommended tools for assembly. Do not use excessive force when tightening screws or bolts.

If any difficulties arise during assembly, consult the troubleshooting section or contact our customer support.

INSTRUCCIONES DE ENSAMBLAJE

Desempaque cuidadosamente todos los componentes y verifique que todas las piezas necesarias estén incluidas, según lo indicado en el empaque.

Identifique cada componente y consulte el diagrama de ensamblaje o las instrucciones paso a paso proporcionadas.

Ensamble los muebles en el orden especificado para asegurar una correcta alineación y ajuste.

Utilice las herramientas proporcionadas o las herramientas recomendadas para el ensamblaje. No use fuerza excesiva al apretar los tornillos o pernos.

Si surge alguna dificultad durante el ensamblaje, consulte la sección de solución de problemas o comuníquese con nuestro servicio de atención al cliente.

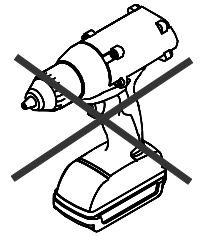

A x 12



M6x15 mm

B x 4

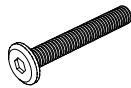

M6x40 mm

C x 4

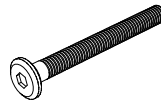

M6x55 mm

D x 16



Ø6x14x1 mm

E x 2



Ø8x16x5 mm

F x 6



M8x20 mm

G x 1

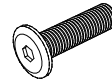

M8x30 mm

H x 1

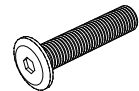

M8x40 mm

J x 22



Ø8x16x1 mm

K x 8



M8 mm

L x 4

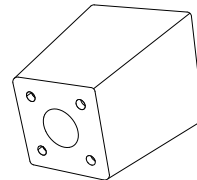

45x45x65 mm

M x 2

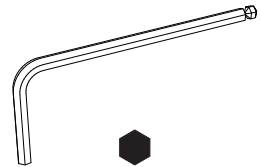

4 mm

N x 1

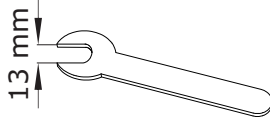

90x25x2 mm

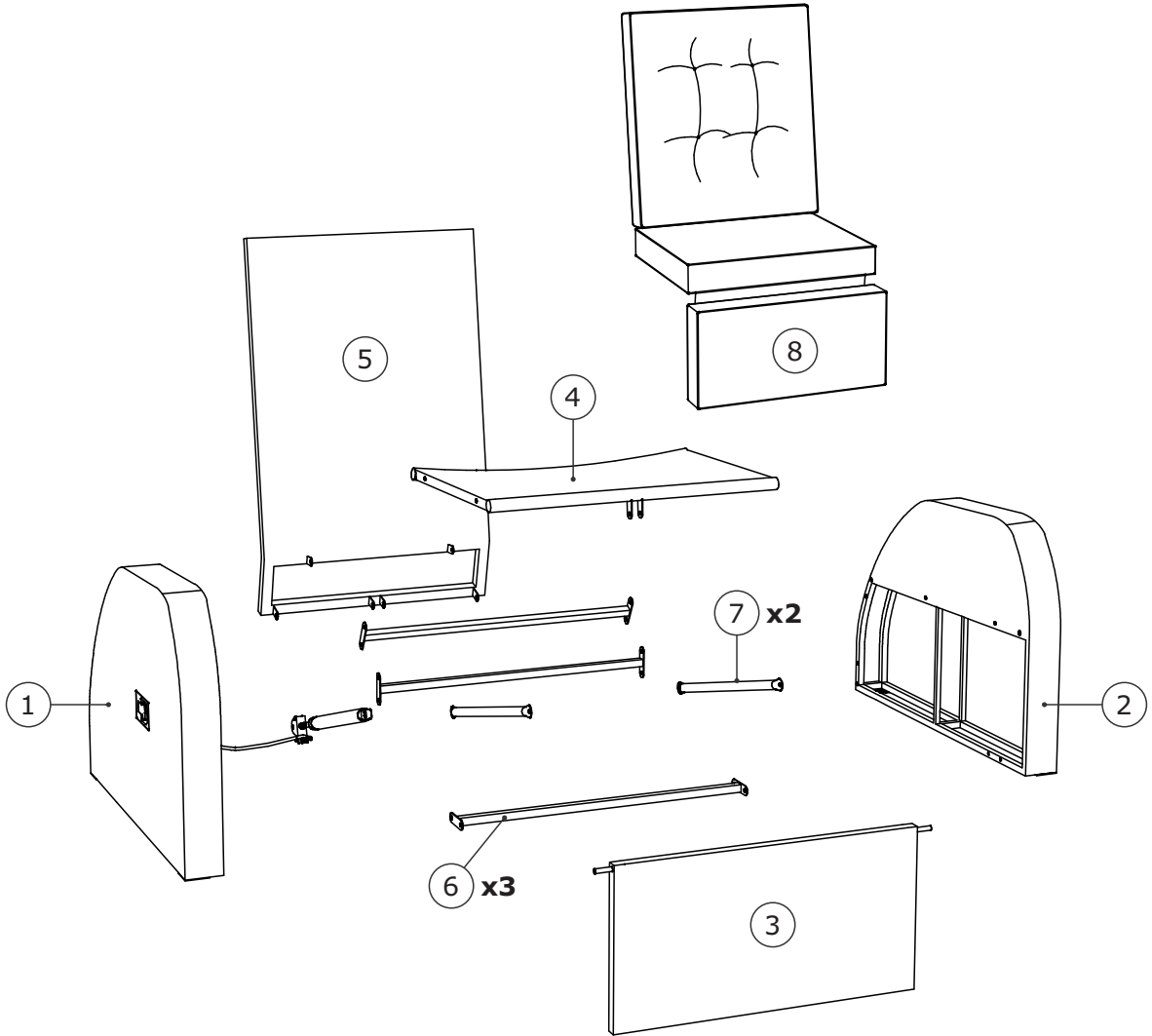
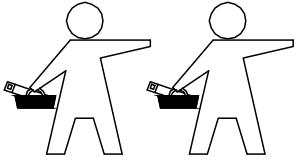

BOX 1/1:

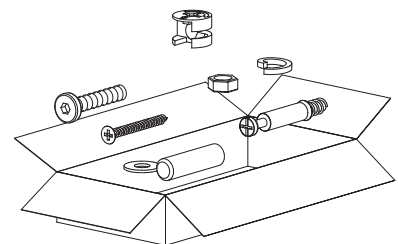
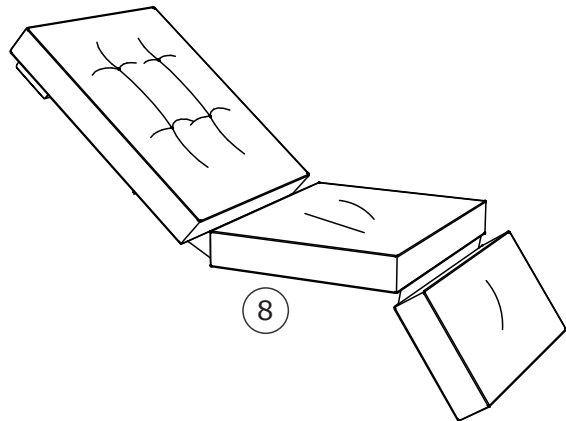
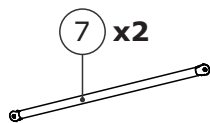
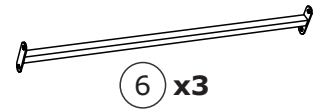
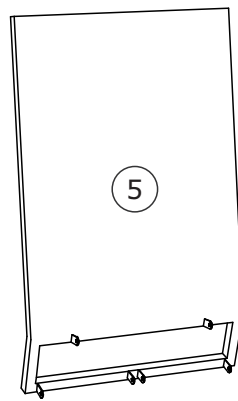
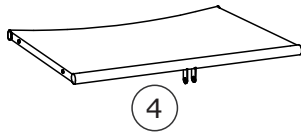
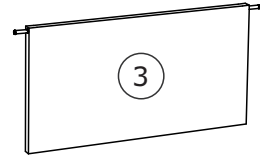
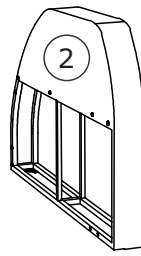
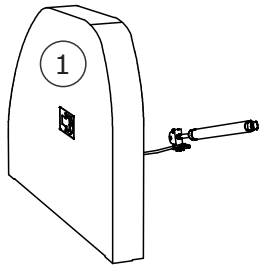

1

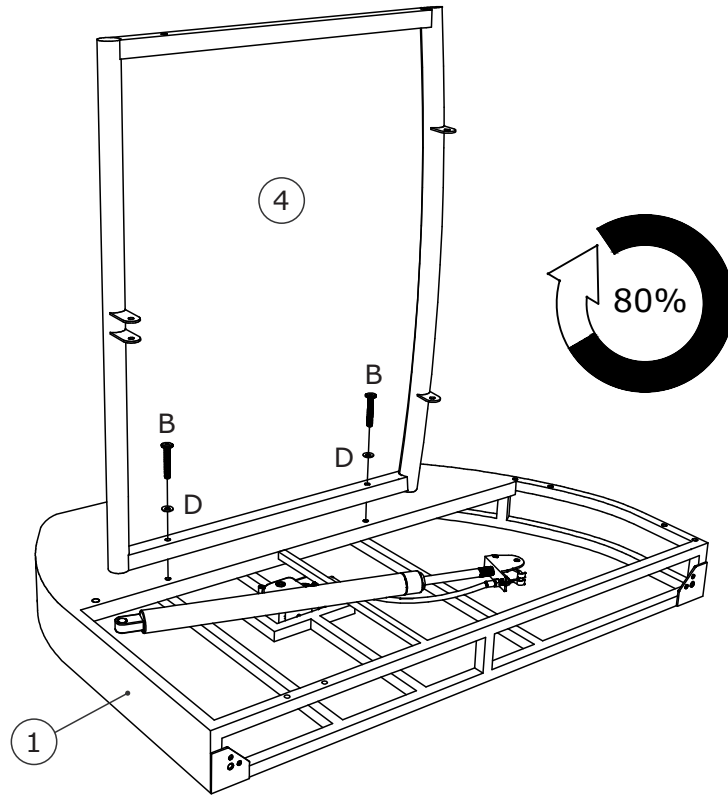

2

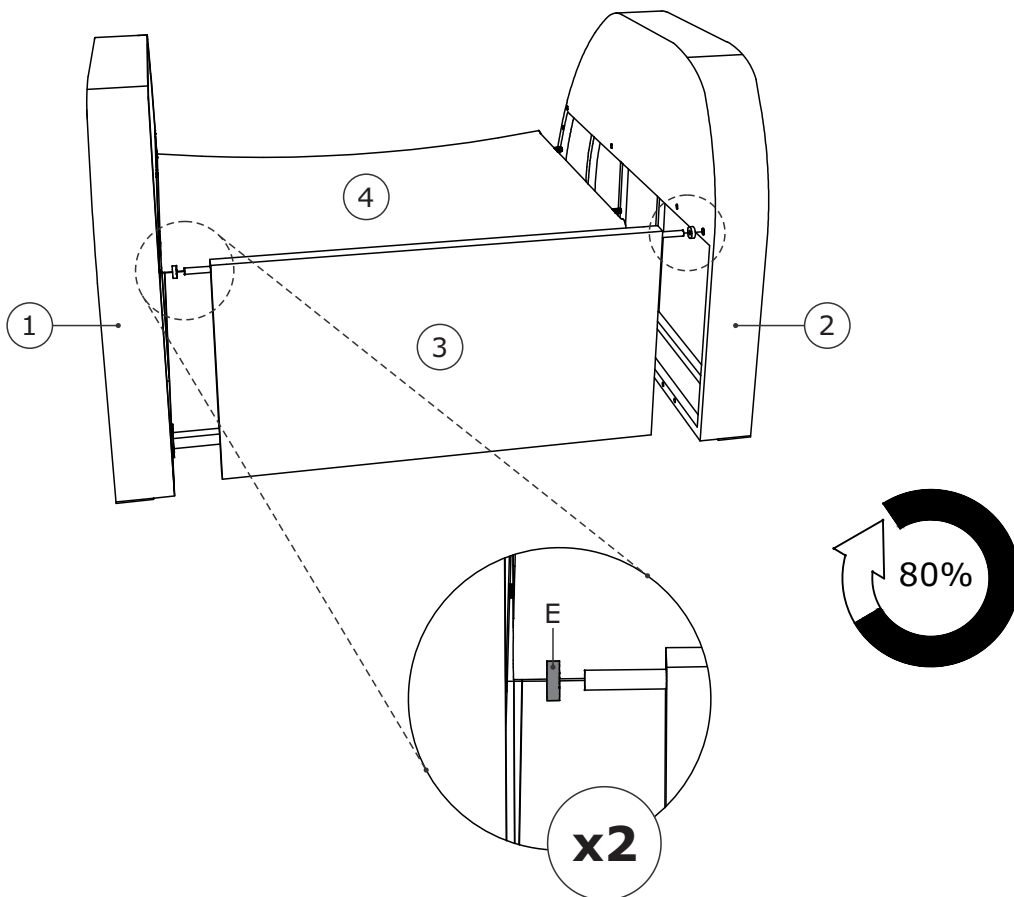

3

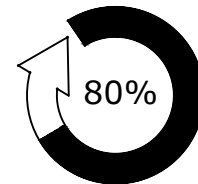
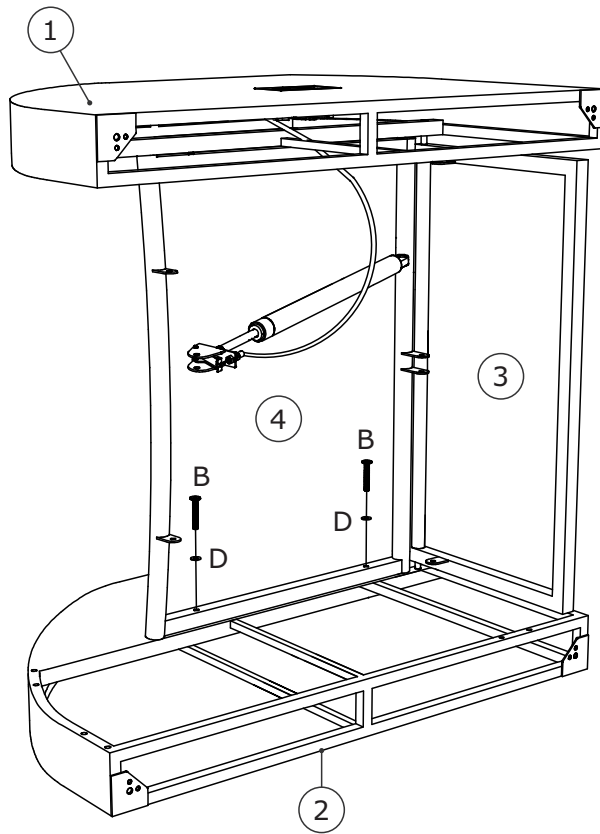

4

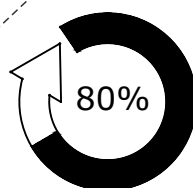
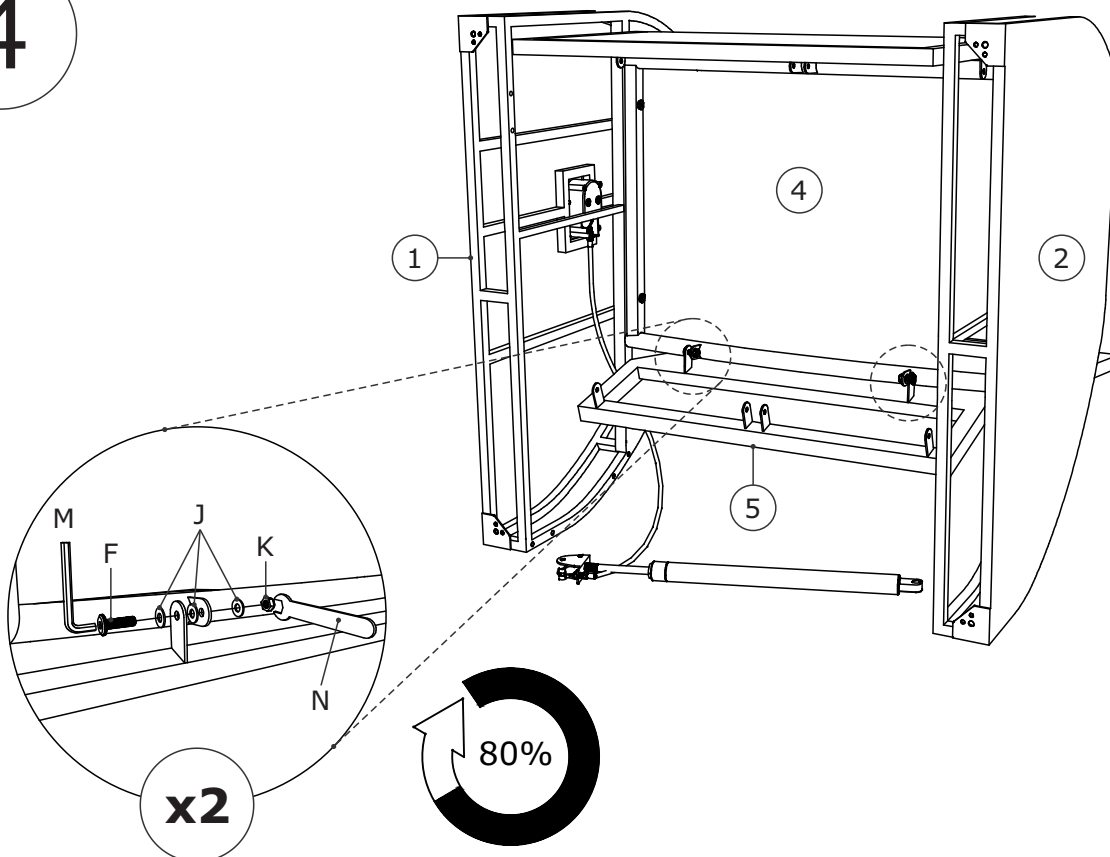

5

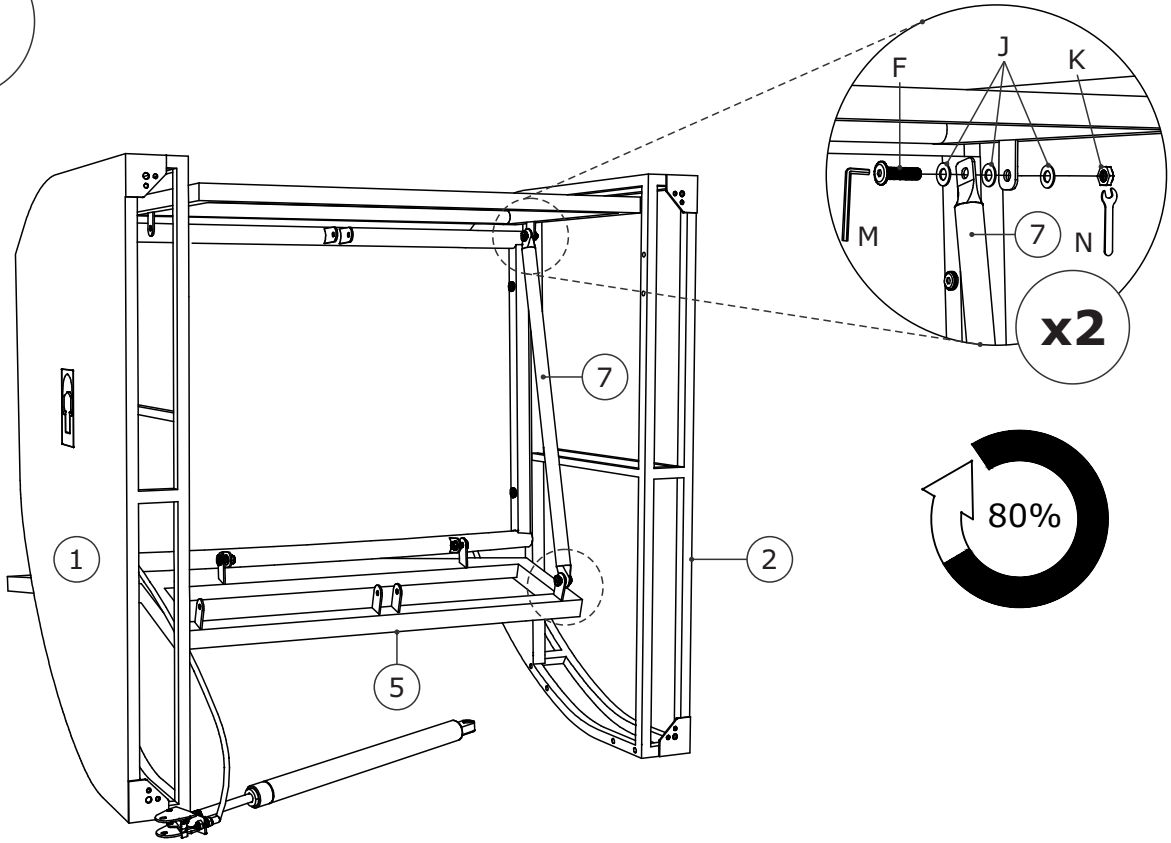

6

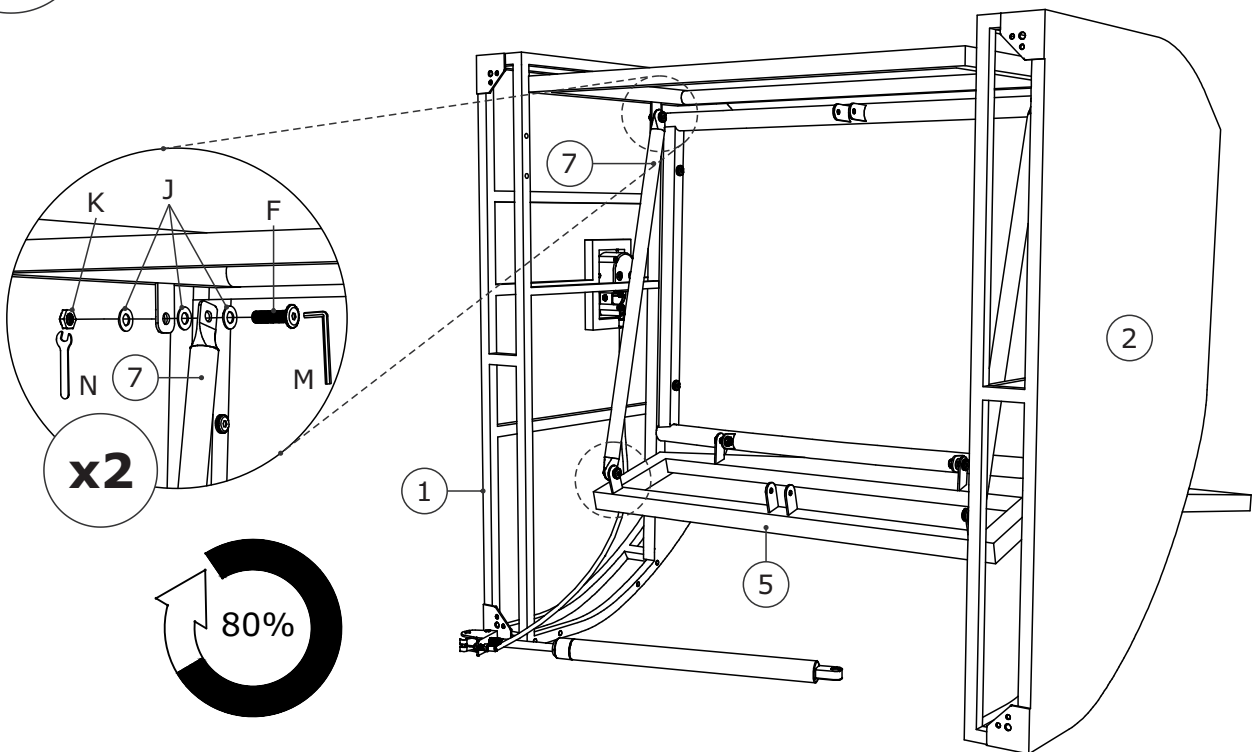

7

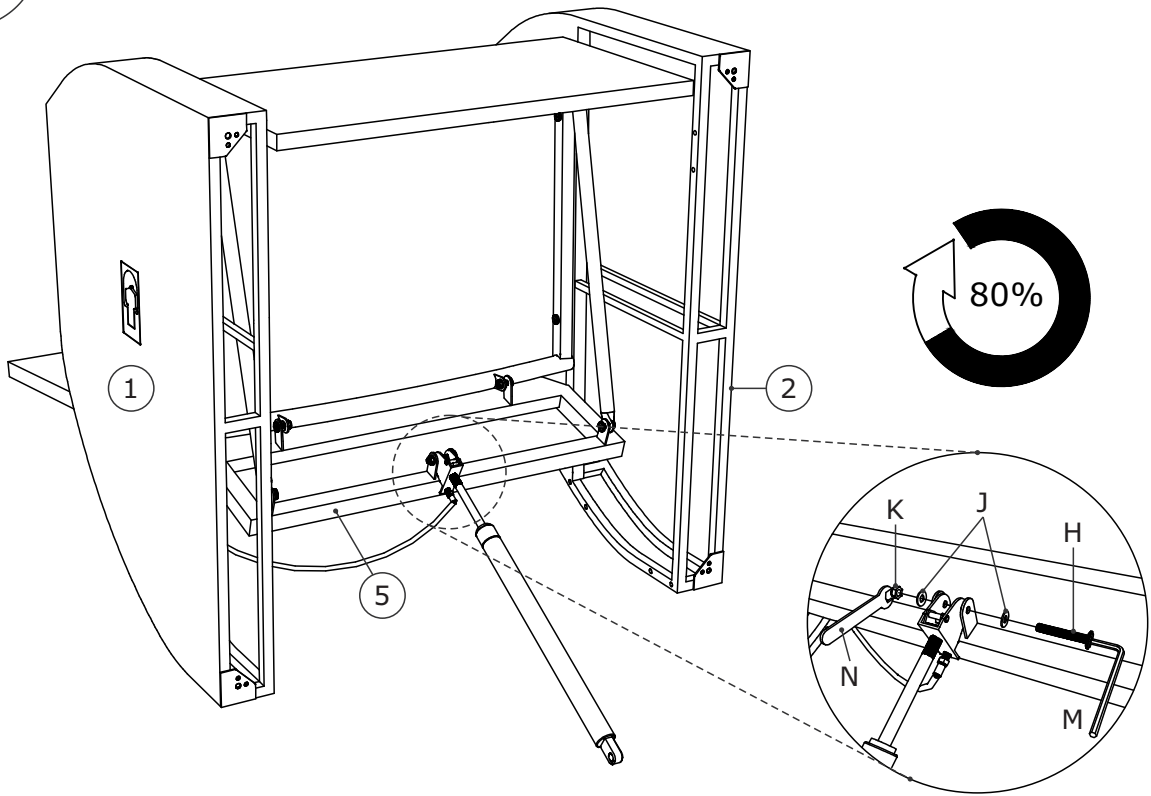

8

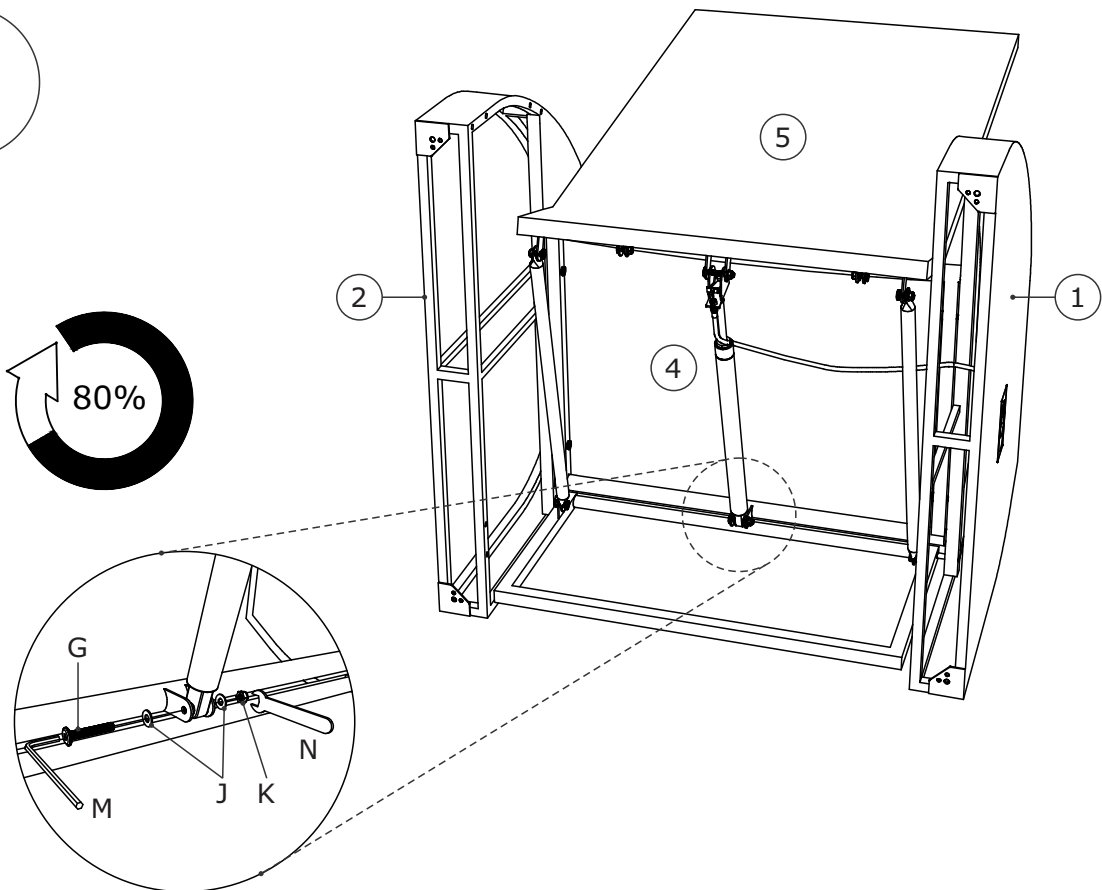

9

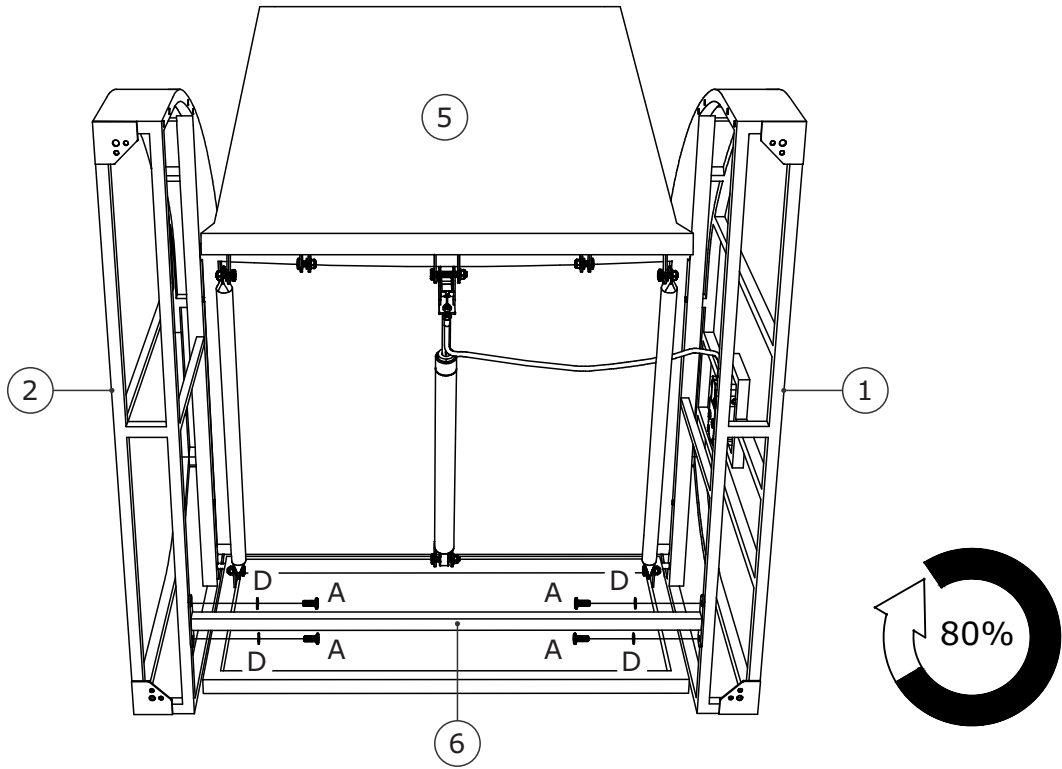

10

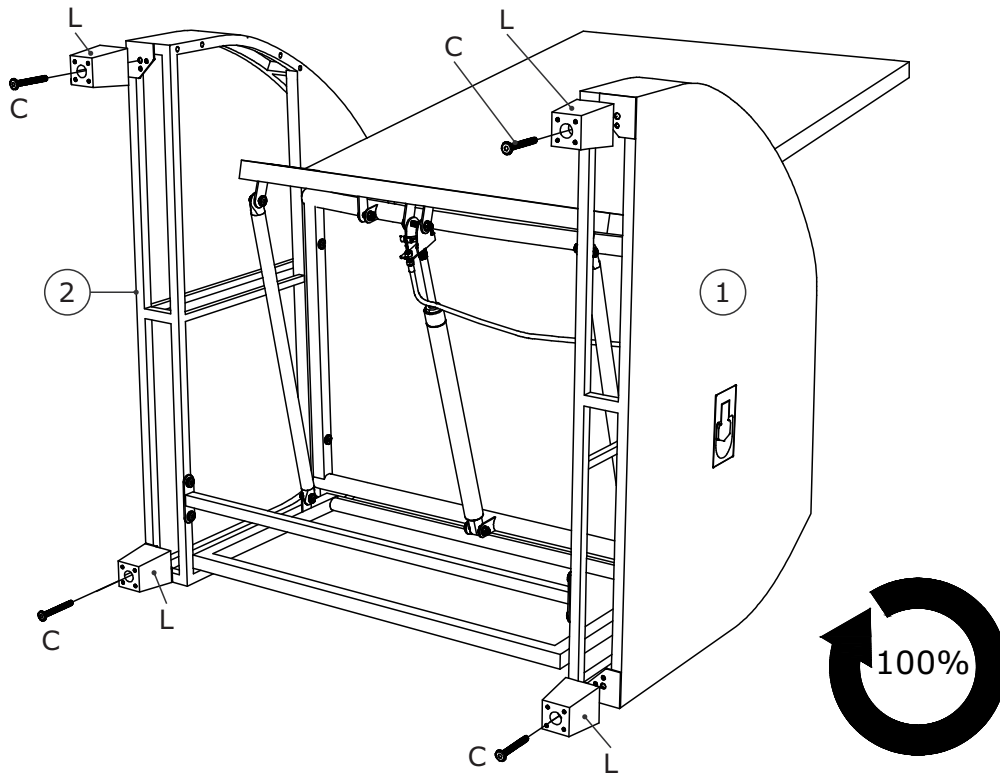

11

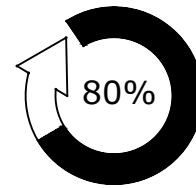
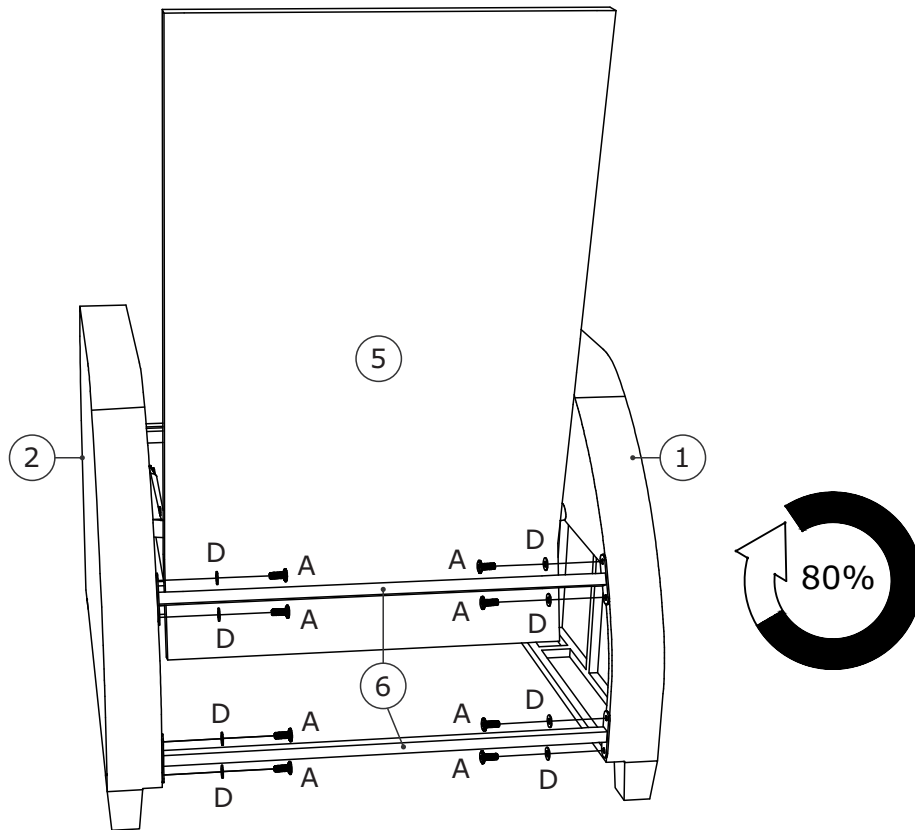

12

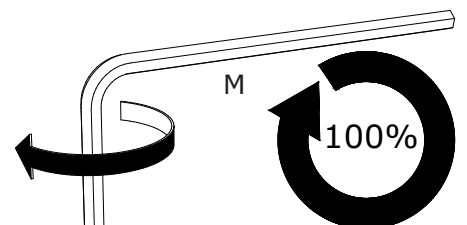
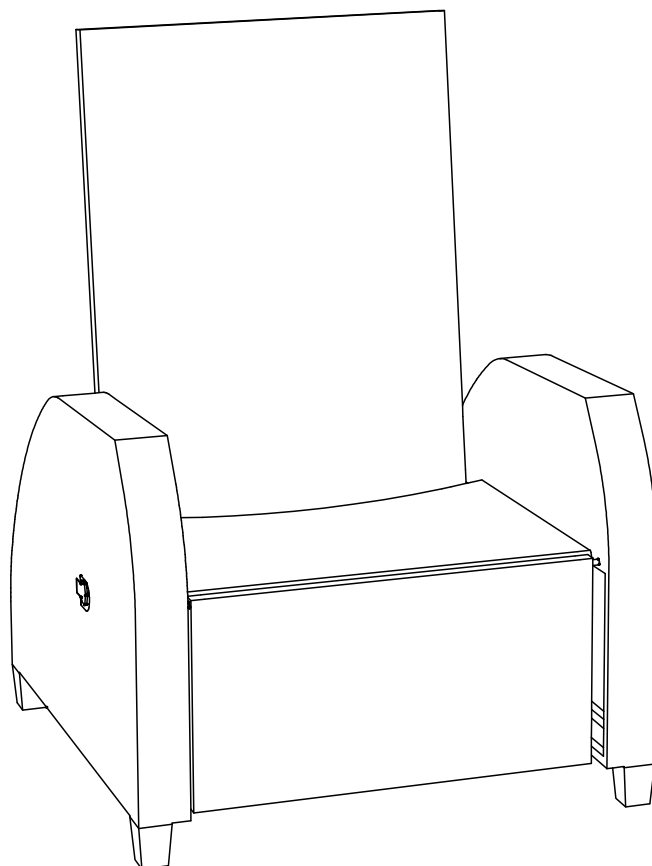

13

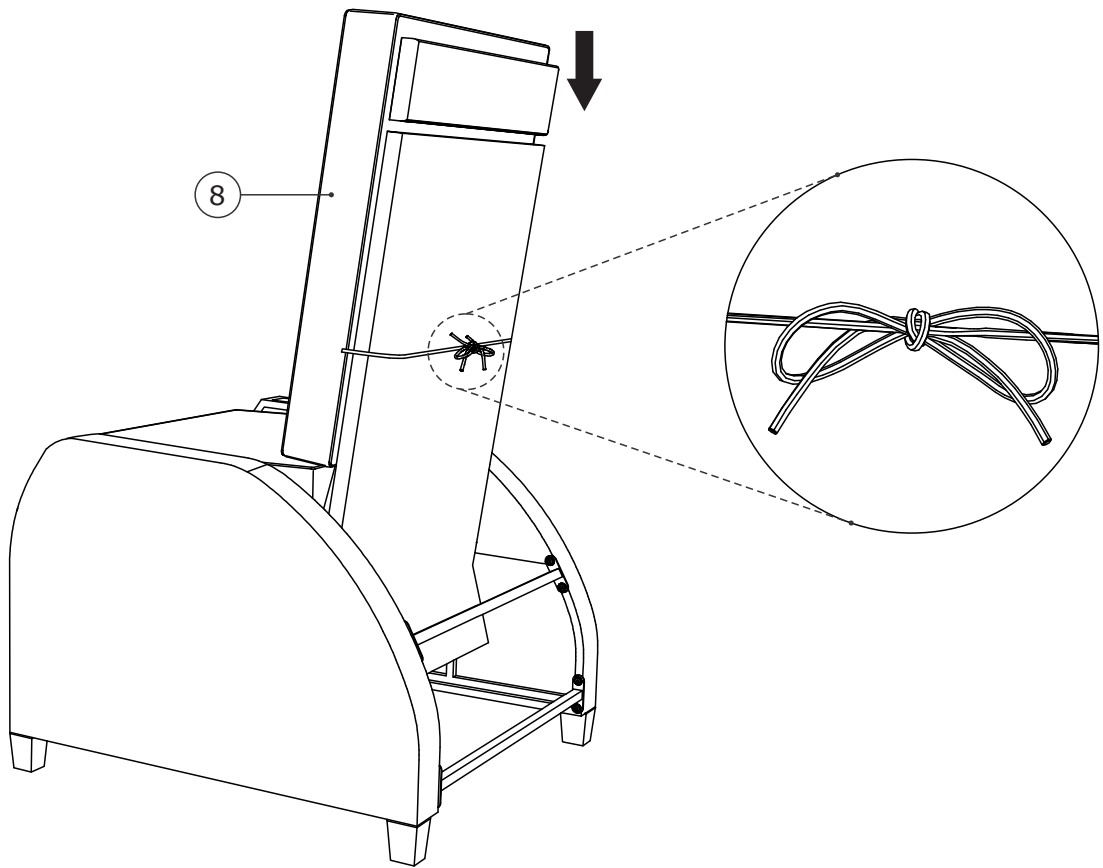

14

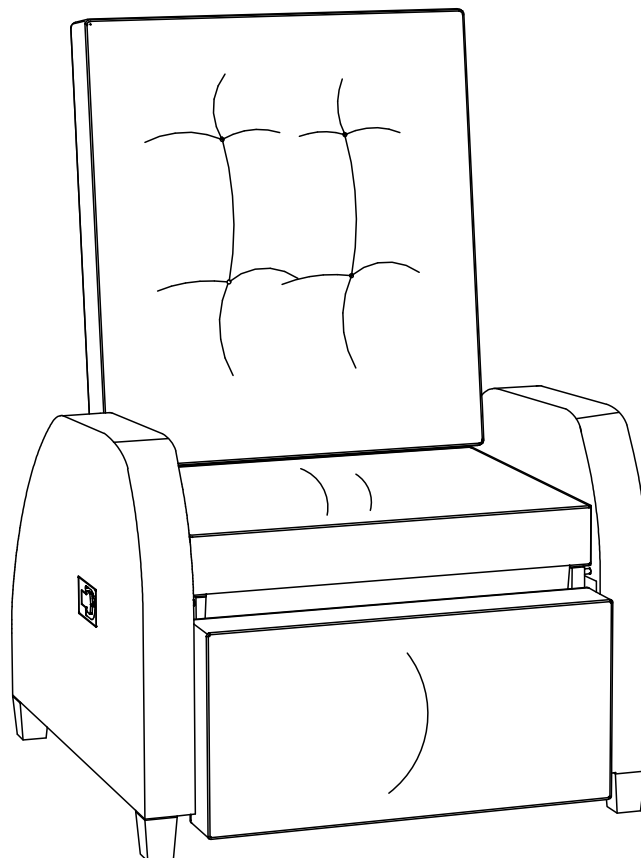

15

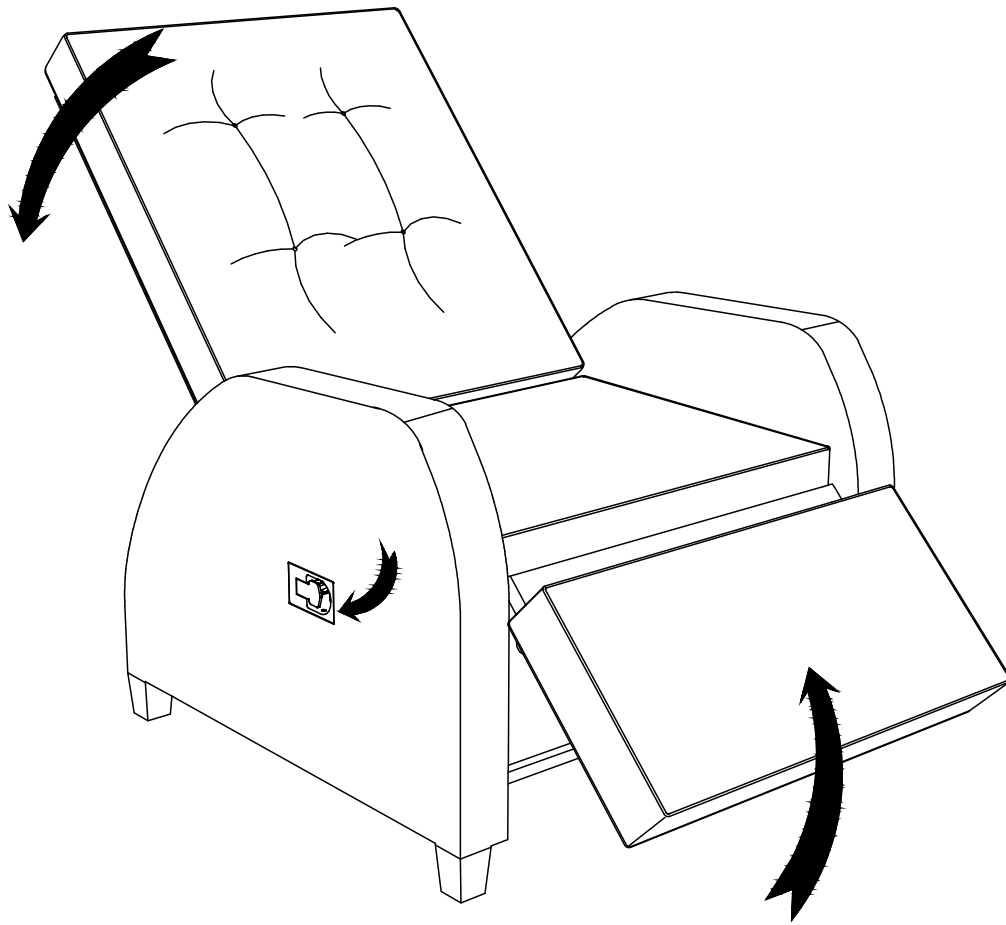



MAINTENANCE AND CARE

Protect your furniture from extreme weather conditions by moving it to a covered area. Alternatively, use furniture covers or traps for added protection.

Avoid dragging or placing heavy objects on the furniture to prevent potential damage.

Regularly inspect your furniture for signs of wear, loose strands, or damage. Address any issues promptly.

Hardware may loosen over time. Periodically check to make sure all connections are tight. Re-tighten if necessary.

Do not dispose of any packaging or contents of the shipping carton until assembly is completed to avoid accidentally discarding small parts or hardware.

Do not use sharp objects that may scratch the painted surface.

Clean with a damp cloth soaked in warm soapy water or a specialized, suitable cleaning product.

Conclude the cleaning process by wiping with a clean, dry cloth.

Ensure proper drying after cleaning or exposure to rain to prevent mold or mildew growth.



WARRANTY INFORMATION

Warranty Coverage: Our warranty provides protection against manufacturing defects in materials and workmanship for a specified period from the date of purchase, as outlined in the accompanying warranty documentation.

Exclusions: The warranty does not cover damages resulting from misuse, negligence, accidents, normal wear and tear, unauthorized repairs or modifications, improper assembly, or failure to adhere to the care and maintenance guidelines provided.

WARRANTY CLAIM PROCESS

To initiate a return on Amazon, please follow these steps:

- 1 Log into your Amazon account and go to the "Your Orders" section.
- 2 Locate the order containing the item you wish to return.
- 3 Contact our customer service for assistance in obtaining a prepaid return label.
- 4 Once you receive the return label, securely affix it to the package.
- 5 You can then choose to drop off the package at a designated carrier location or arrange for a pickup.
- 6 After we receive and inspect the returned product, we will initiate the refund process.
- 7 The refund will be credited back to the original payment method used during the purchase.
- 8 Typically, refunds are processed within 3-5 business days.



Contact Information

If you have any questions, concerns, or need assistance, please reach out to our customer support team using the contact information provided below:

Customer Support Email

support@royalcraft.store



MANTENIMIENTO Y CUIDADO

Proteja sus muebles de condiciones climáticas extremas moviéndolos a un área cubierta. Alternativamente, use fundas o protectores para muebles para una protección adicional. Evite arrastrar o colocar objetos pesados sobre los muebles para prevenir posibles daños. Inspeccione regularmente sus muebles en busca de signos de desgaste, hilos sueltos o daños. Trate cualquier problema de inmediato.

Los herrajes pueden aflojarse con el tiempo. Revise periódicamente para asegurarse de que todas las conexiones estén ajustadas. Vuelva a apretar si es necesario.

No deseche ningún embalaje o contenido de la caja de envío hasta que se complete el ensamblaje para evitar descartar accidentalmente partes pequeñas o herrajes.

No use objetos afilados para rasgar la superficie pintada. No recomendamos el uso de limpiadores químicos, abrasivos o pulidores de muebles en nuestro acabado lacado.

Limpie con un paño húmedo empapado en agua jabonosa tibia o un producto de limpieza especializado y adecuado.

Concluya el proceso de limpieza secando con un paño limpio y seco.

Asegúrese de que los muebles se sequen adecuadamente después de la limpieza o la exposición a la lluvia para evitar el crecimiento de moho o hongos.

Evite colocar vasos transparentes sobre la superficie del panel de madera-plástico durante mucho tiempo para evitar que la luz solar concentrada derrita la superficie.



INFORMACIÓN DE GARANTÍA

Cobertura de la garantía: Nuestra garantía proporciona protección contra defectos de fabricación en materiales y mano de obra durante un período especificado desde la fecha de compra, como se detalla en la documentación de garantía adjunta.

Exclusiones: La garantía no cubre daños resultantes de mal uso, negligencia, accidentes, desgaste normal, reparaciones o modificaciones no autorizadas, ensamblaje incorrecto o el incumplimiento de las pautas de cuidado y mantenimiento proporcionadas.

PROCESO DE RECLAMO DE GARANTÍA

Para iniciar una devolución en Amazon, siga estos pasos:

- 1 Inicie sesión en su cuenta de Amazon y vaya a la sección "Tus pedidos".
- 2 Ubique el pedido que contiene el artículo que desea devolver.
- 3 Póngase en contacto con nuestro servicio al cliente para recibir asistencia y obtener una etiqueta de devolución prepaga.
- 4 Una vez reciba la etiqueta de devolución, colóquela de manera segura en el paquete.
- 5 Luego, puede optar por dejar el paquete en un punto de entrega designado o coordinar una recogida.
- 6 Después de recibir e inspeccionar el producto devuelto, iniciaremos el proceso de reembolso.
- 7 El reembolso será acreditado al método de pago original utilizado durante la compra.
- 8 Por lo general, los reembolsos se procesan dentro de un plazo de 3 a 5 días hábiles.



Información de Contacto

Si tiene alguna pregunta, inquietud o necesita asistencia, por favor, póngase en contacto con nuestro equipo de atención al cliente utilizando la información de contacto proporcionada a continuación:

Correo electrónico de atención al cliente

support@royalcraft.store
