

ASSEMBLY INSTRUCTIONS

DINING TABLE

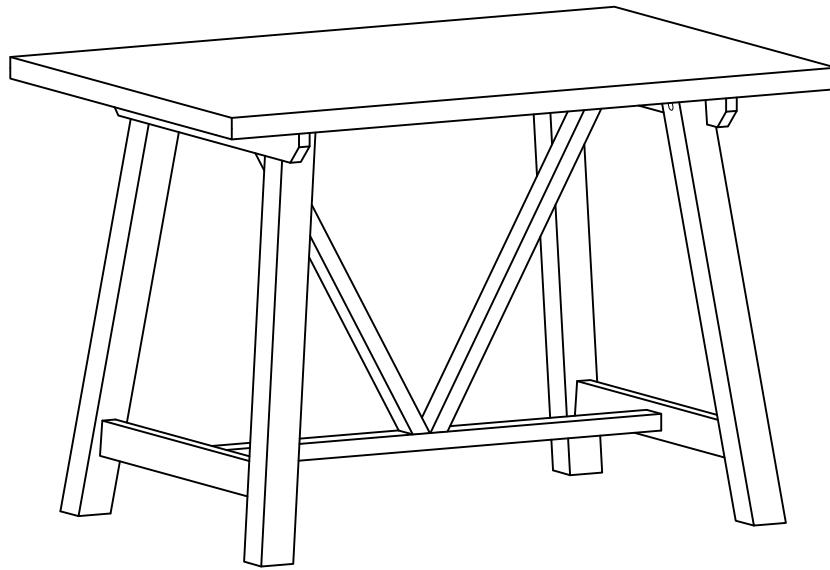

WF305196

IMPORTANT NOTE:

- PLACE ALL PARTS ON A CLEAN AND SMOOTH SURFACE SUCH AS A RUG OR CARPET TO AVOID THE PARTS FROM BEING SCRATCHED.
- BEFORE YOU BEGIN, KINDLY FOLLOW THE ASSEMBLY INSTRUCTIONS STEP BY STEP.
- DO NOT TIGHTEN ALL SCREWS AND BOLTS UNTIL THE TABLE IS FULLY SET-UP.

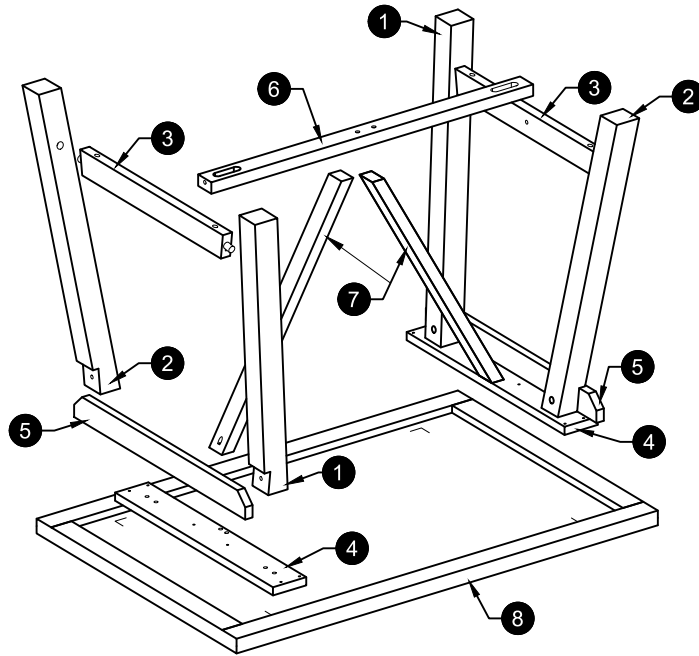

CARTON CONTENT:

WF305196 :

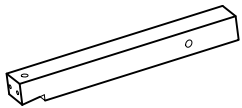

1 x 2

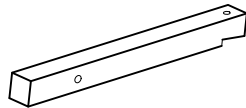

2 x 2

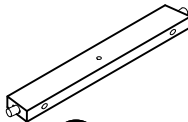

3 x 2

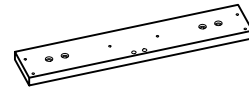

4 x 2



5 x 2

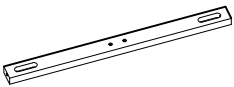

6 x 1



7 x 2

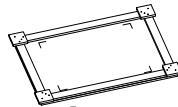

8 x 1

TABLE PART LISTS

| NO. | DESCRIPTION | SKETCH | QTY |
|-----|---------------------|--------|-------|
| 1 | TABLE LEG (R) | | 2 PCS |
| 2 | TABLE LEG (L) | | 2 PCS |
| 3 | TABLE LEG STRETCHER | | 2 PCS |
| 4 | TABLE LEG TOP | | 2 PCS |
| 5 | TABLE LEG DECO | | 2 PCS |
| 6 | MIDDLE BAR | | 1 PC |
| 7 | TABLE LEG V | | 2 PCS |
| 8 | TABLE TOP | | 1 PC |

TABLE HARDWARE LISTS

| NO. | DESCRIPTION | SKETCH | QTY |
|-----|-------------------------|--------|--------|
| A | JCBC BOLT M6 x 45mm | | 14 PCS |
| B | SPRING WASHER 1/4" | | 14 PCS |
| C | WOOD DOWEL M8 x 30mm | | 4 PCS |
| D | C/B SCREW M4 x 30mm | | 14 PCS |
| E | C/B SCREW M4 x 45mm | | 6 PCS |
| F | ALLEN KEY M4 | | 1 PC |

STEP 1

DO NOT TIGHTEN ALL SCREWS AND BOLTS UNTIL THE BENCH IS FULLY SET-UP.

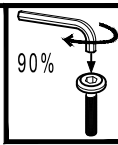
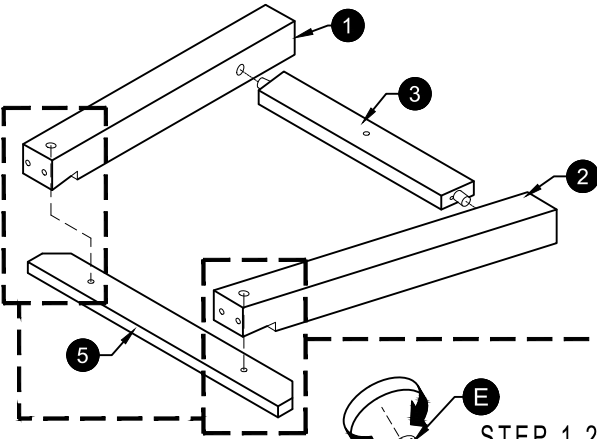

STEP 2

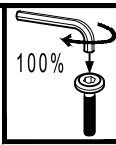
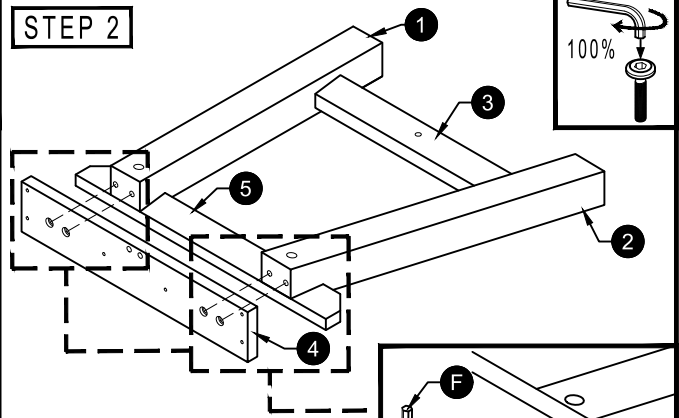

STEP 1.1

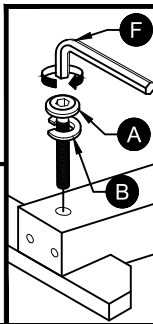

• Tighten first step 2, then continue with step 1.1

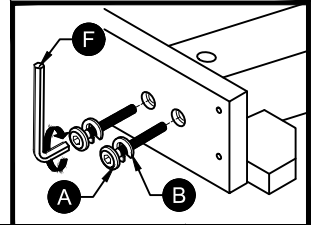

STEP 3

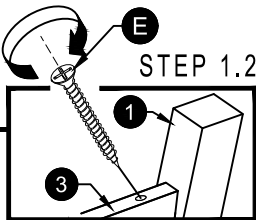
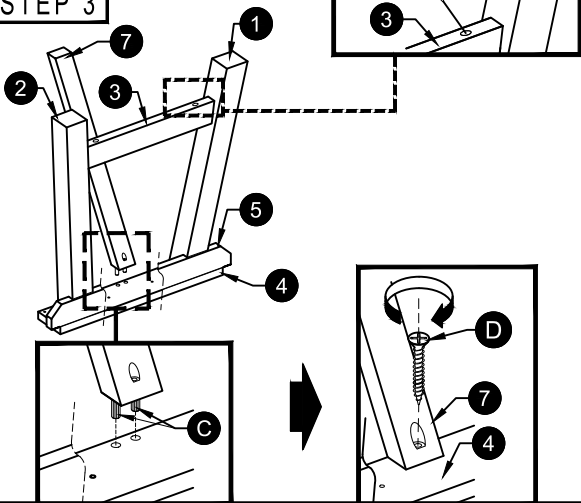

STEP 4

STEP 4.2

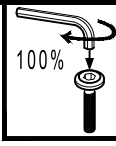
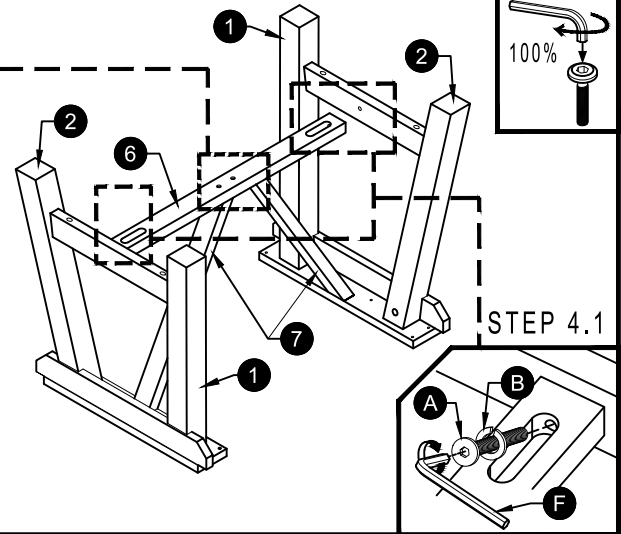
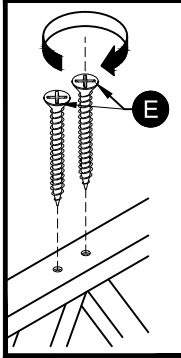

STEP 4.1

STEP 5

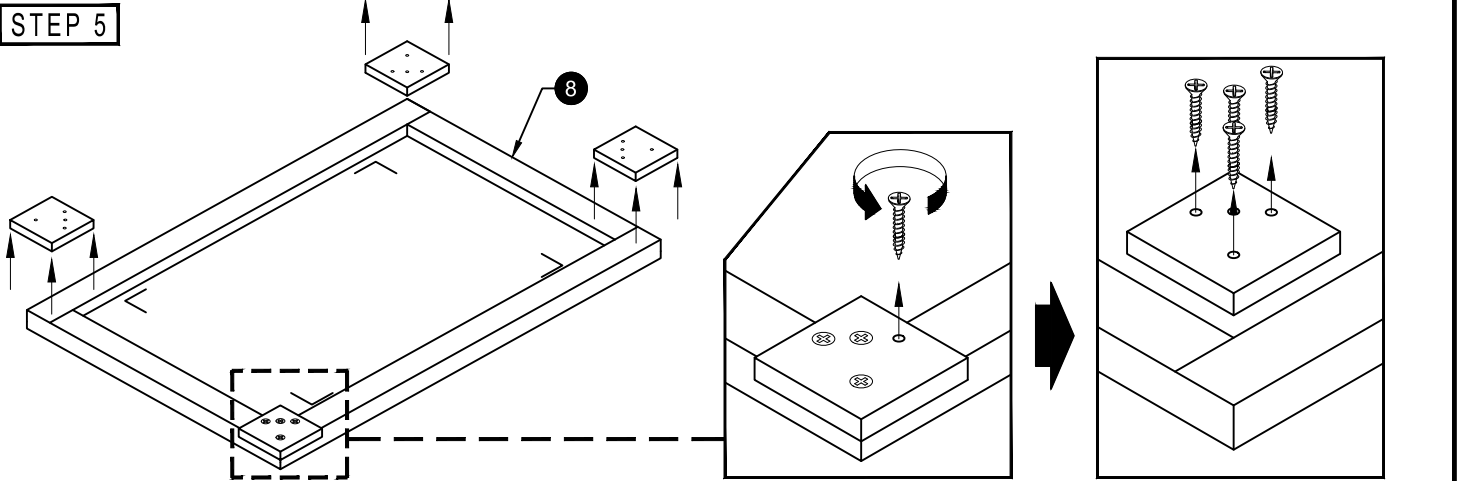

STEP 6

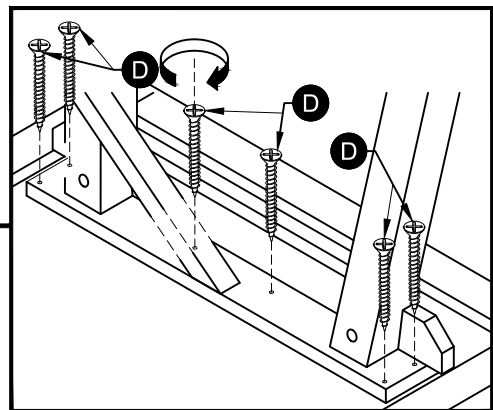
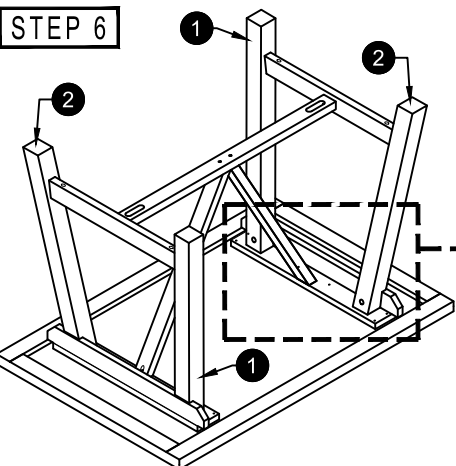

ASSEMBLY COMPLETE !

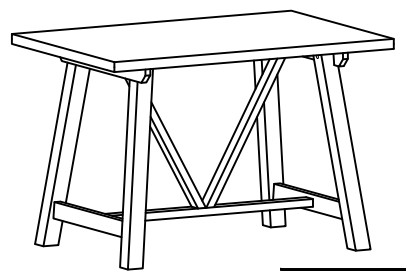

ASSEMBLY INSTRUCTIONS

DINING CHAIR

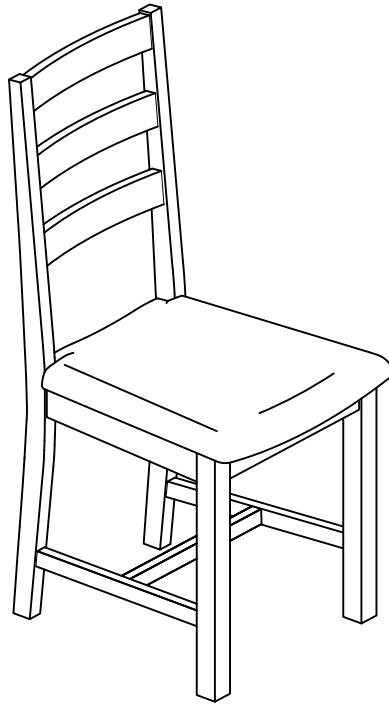

WF305198

IMPORTANT NOTE:

- PLACE ALL PARTS ON A CLEAN AND SMOOTH SURFACE SUCH AS A RUG OR CARPET TO AVOID THE PARTS FROM BEING SCRATCHED.
- BEFORE YOU BEGIN, KINDLY FOLLOW THE ASSEMBLY INSTRUCTIONS STEP BY STEP.
- DO NOT TIGHTEN ALL SCREWS AND BOLTS UNTIL THE CHAIR IS FULLY SET-UP.

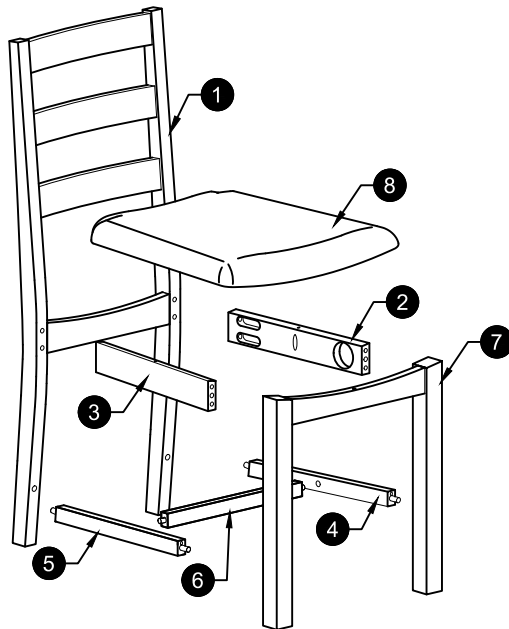

CARTON CONTENT:

WF305198 :

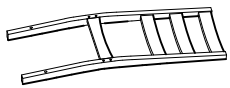

1 x 2

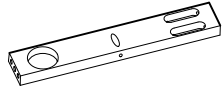

2 x 2

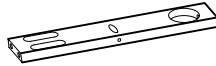

3 x 2

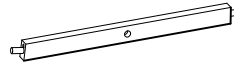

4 x 2

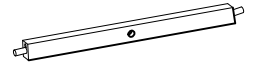

5 x 2



6 x 2

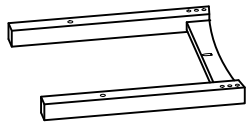

7 x 2



8 x 2

CHAIR PART LISTS

| NO. | DESCRIPTION | SKETCH | QTY |
|-----|-------------|--------|-------|
| 1 | BACK LEG | | 2 PCS |
| 2 | SIDE RAIL-R | | 2 PCS |
| 3 | SIDE RAIL-L | | 2 PCS |
| 4 | STRETCHER-R | | 2 PCS |
| 5 | STRETCHER-L | | 2 PCS |
| 6 | STRETCHER-M | | 2 PCS |
| 7 | FRONT LEG | | 2 PCS |
| 8 | SEAT | | 2 PCS |

CHAIR HARDWARE LISTS

| NO. | DESCRIPTION | SKETCH | QTY |
|-----|-------------------------|--------|--------|
| A | JCBC BOLT M6 x 50mm | | 12 PCS |
| B | SPRING WASHER 1/4" | | 12 PCS |
| C | WOOD DOWEL M8 x 30mm | | 8 PCS |
| D | C/B SCREW M4 x 30mm | | 10 PCS |
| E | C/B SCREW M4 x 45mm | | 8 PCS |
| F | ALLEN KEY M4 | | 1 PC |

STEP 1

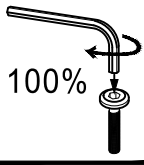
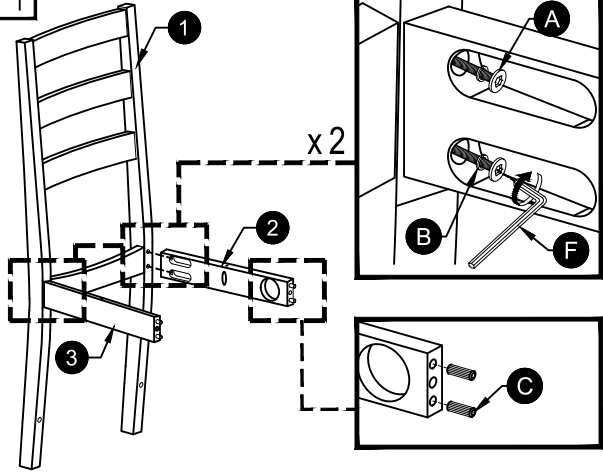

STEP 2

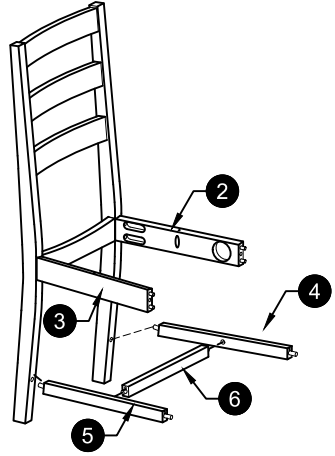

STEP 3

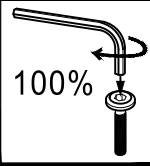
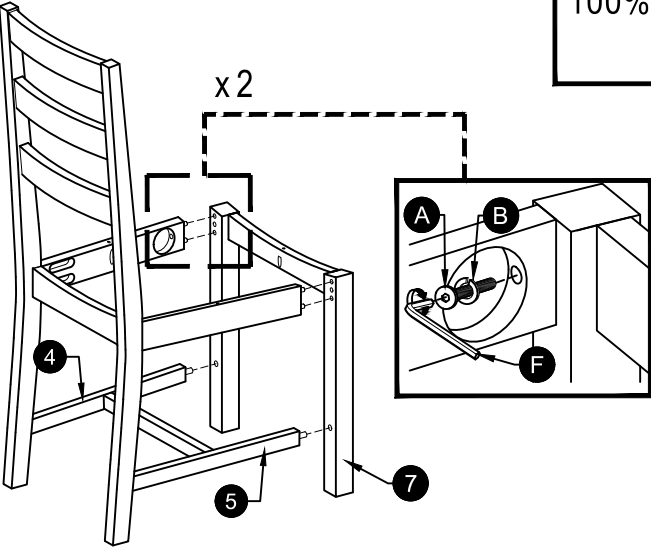

STEP 4

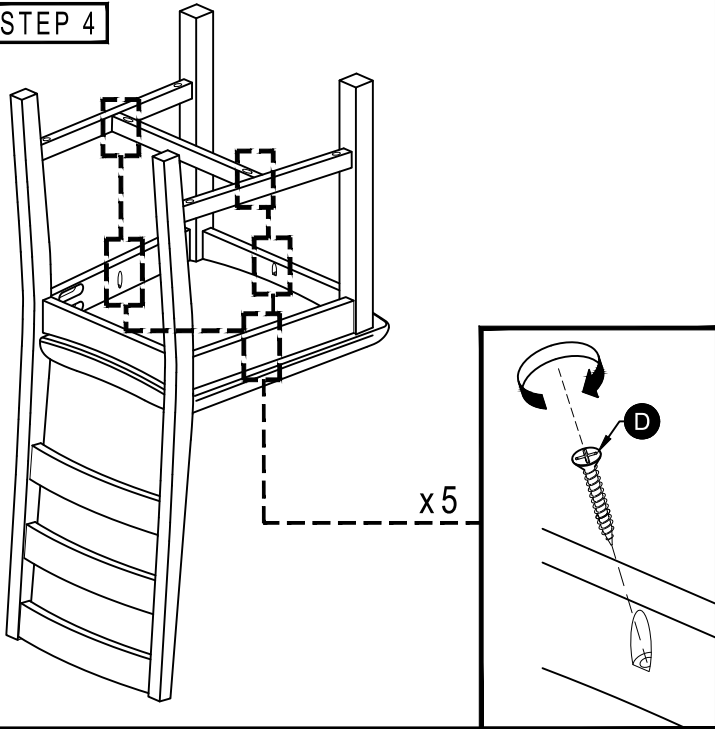

STEP 5

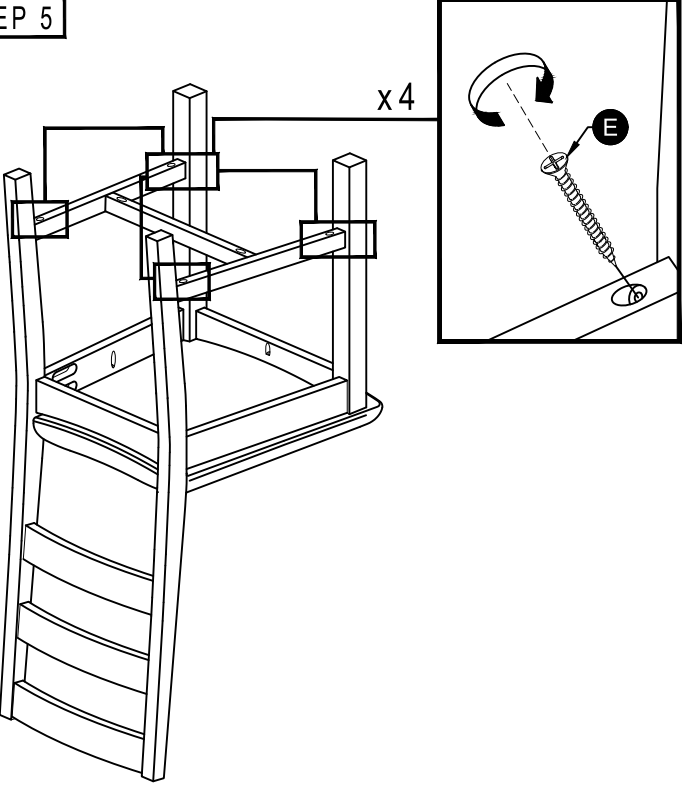

ASSEMBLY COMPLETE !

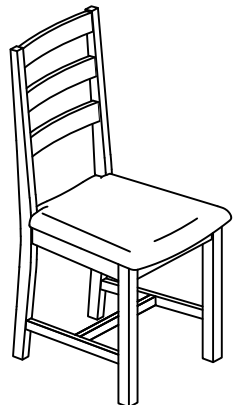

ASSEMBLY INSTRUCTIONS

DINING BENCH

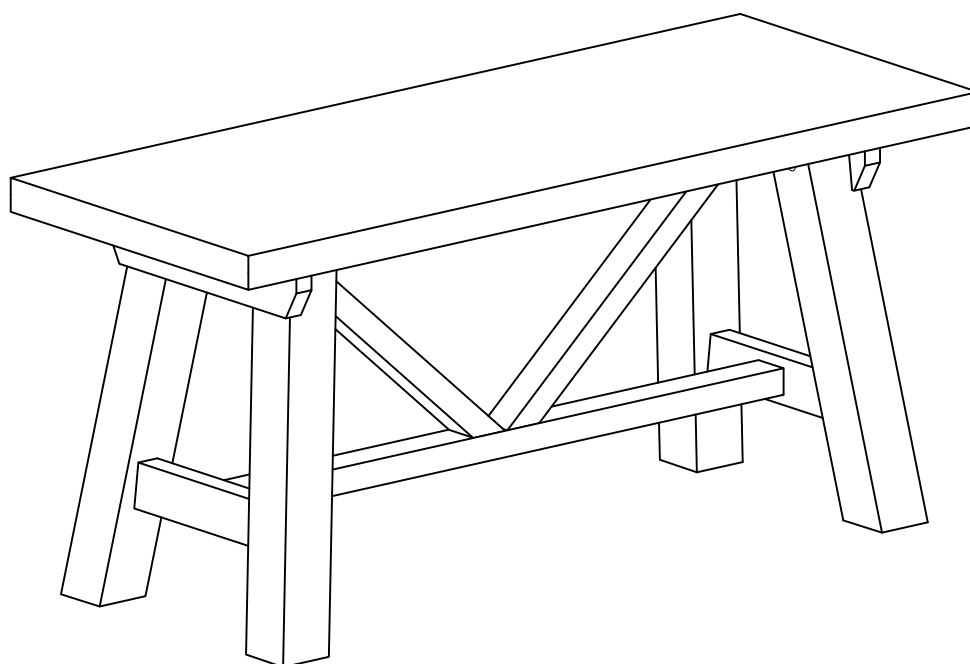

WF305198

IMPORTANT NOTE:

- PLACE ALL PARTS ON A CLEAN AND SMOOTH SURFACE SUCH AS A RUG OR CARPET TO AVOID THE PARTS FROM BEING SCRATCHED.
- BEFORE YOU BEGIN, KINDLY FOLLOW THE ASSEMBLY INSTRUCTIONS STEP BY STEP.
- DO NOT TIGHTEN ALL SCREWS AND BOLTS UNTIL THE BENCH IS FULLY SET-UP.

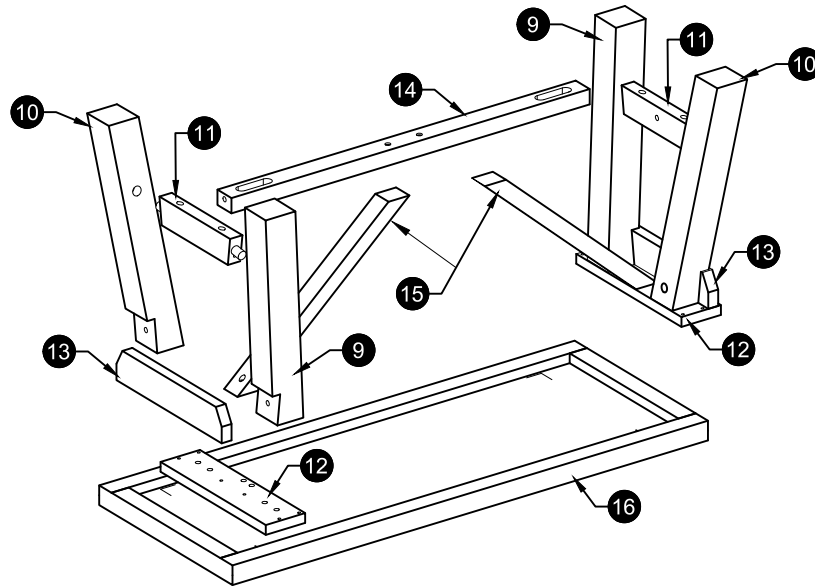

CARTON CONTENT:

WF305198 :

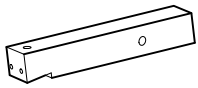

9 x 2

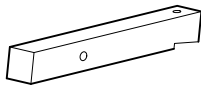

10 x 2

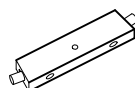

11 x 2

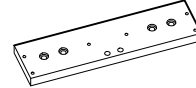

12 x 2

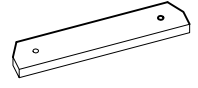

13 x 2

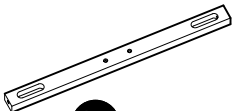

14 x 1

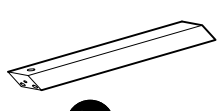

15 x 2

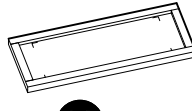

16 x 1

BENCH PART LISTS

| NO. | DESCRIPTION | SKETCH | QTY |
|-----|---------------------|--------|-------|
| 9 | BENCH LEG (R) | | 2 PCS |
| 10 | BENCH LEG (L) | | 2 PCS |
| 11 | BENCH LEG STRETCHER | | 2 PCS |
| 12 | BENCH LEG TOP | | 2 PCS |
| 13 | BENCH LEG DECO | | 2 PCS |
| 14 | MIDDLE BAR | | 1 PC |
| 15 | BENCH V | | 2 PCS |
| 16 | SEAT | | 1 PC |

BENCH HARDWARE LISTS

| NO. | DESCRIPTION | SKETCH | QTY |
|-----|-------------------------|--------|--------|
| G | JCBC BOLT M6 x 45mm | | 14 PCS |
| H | SPRING WASHER 1/4" | | 14 PCS |
| I | WOOD DOWEL M8 x 30mm | | 4 PCS |
| J | C/B SCREW M4 x 30mm | | 14 PCS |
| K | C/B SCREW M4 x 45mm | | 6 PCS |
| L | ALLEN KEY M4 | | 1 PC |

STEP 1

DO NOT TIGHTEN ALL SCREWS AND BOLTS UNTIL THE BENCH IS FULLY SET-UP.

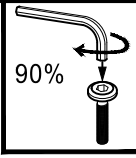

STEP 2

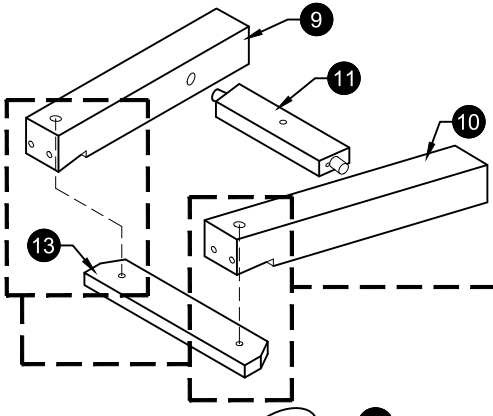
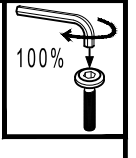

STEP 1.1

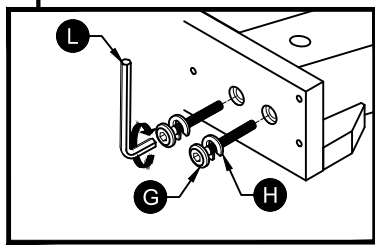
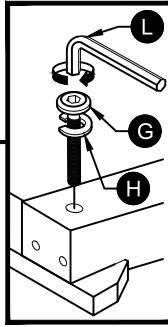

• Tighten first step 2, then continue with step 1.1

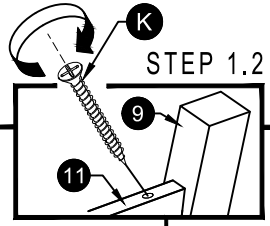

STEP 3

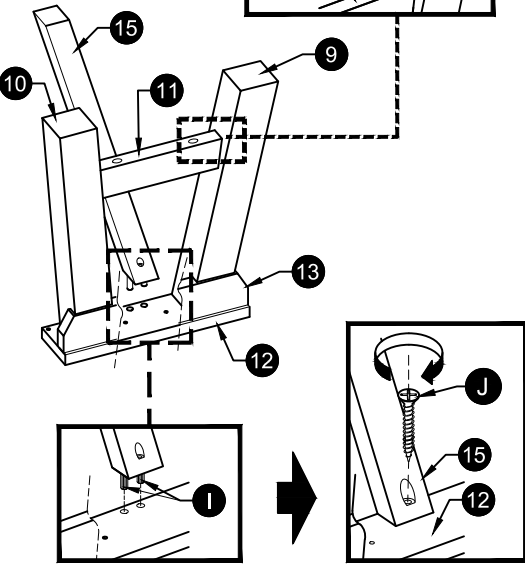

STEP 4

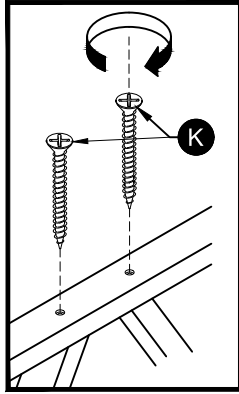

STEP 4.2

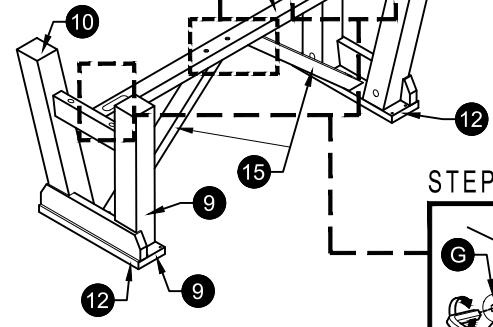

STEP 4.1

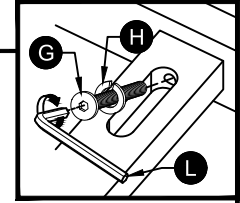

STEP 5

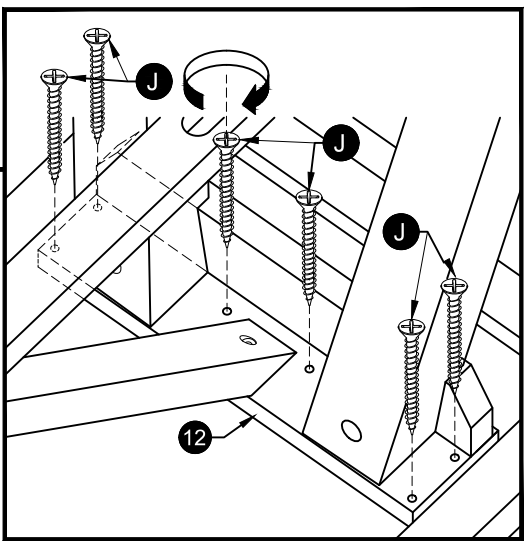
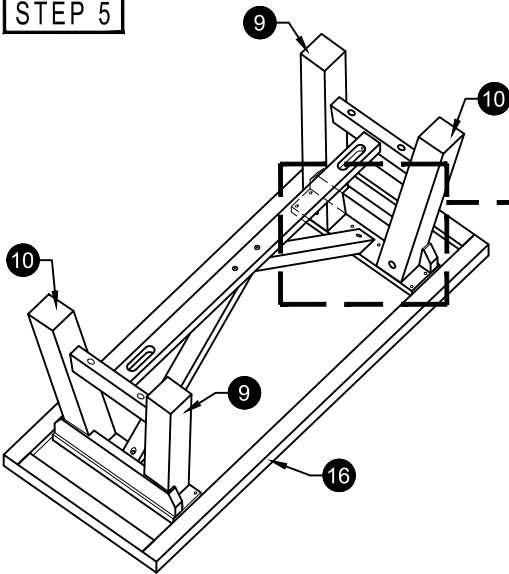

ASSEMBLY COMPLETE !

