

HEADBOARD



PARTS LIST

- ① HEADBOARD PANEL BOARDS 4 PCS
- ② LEFT LEG 1 PC
- ③ RIGHT LEG 1 PC
- ④ HEADBOARD SUPPORT 1 PC

Instructions apply for bed sizes
FULL > QUEEN

HARDWARE

- | | | |
|---|--|--|
| <ul style="list-style-type: none"> Ⓐ JCB M6 X 35mm - 16 pcs
Spare - 1 pc Ⓑ JCB M8 X 15mm (5/8") - 4 pcs
<i>Assembly headboard to open bed frame</i> | <ul style="list-style-type: none"> Ⓒ Allen wrench - 1 pc
Spare - 1 pc Ⓓ Wood screw 1 1/4"-4 pcs
Spare - 1 pc | <p>HARDWARE FOR METAL BED FRAME</p> <ul style="list-style-type: none"> Ⓔ JCB M6 X 25mm (1") - 4 pcs
Spare - 1 pc Ⓕ Flat washer - 4 pcs
Spare - 1 pc Ⓖ Split washer - 4 pcs
Spare - 1 pc |
|---|--|--|

NOTE: WE INCLUDE SPARE HARDWARE IN CASE DAMAGE OCCURS DURING ASSEMBLY.

Step 1

Attach the legs (2) and (3) to headboard panel boards (1) using JCB M6 X 35mm (A). Tighten with the Allen wrench (G).

Step 2

Attach headboard support (4) to headboard panel boards using wood screw 1 1/4" (C) Tighten with the Phillips head screw driver. (Customer supplied)

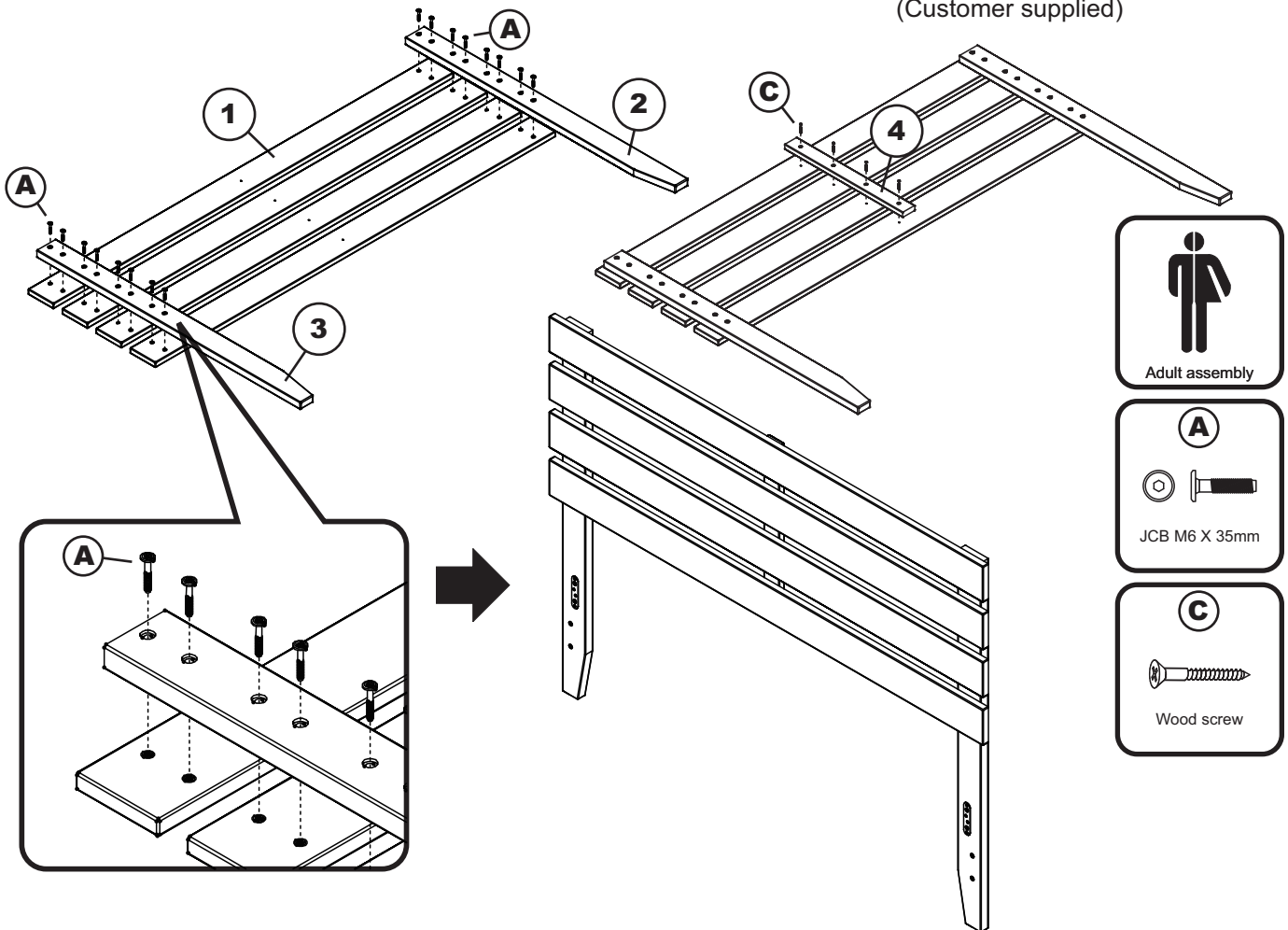

FOR BED FRAME ASSEMBLY follow assembly instructions included with your bed frame.
If you purchased a wood headboard to attach to metal bed frame, please refer to page 2.

ATTACHING HEADBOARD TO METAL BED FRAME

ASSEMBLY INSTRUCTIONS

Before assembling your bed, please read through these instructions carefully and familiarize yourself with the different parts.

Instructions apply for bed sizes
Twin > Full > Queen



Adult assembly

Metal bed frames are sold separately from wood headboards. The hardware shown on this page is supplied with your wood headboard for attaching the bed frame to the headboard. The metal bed frame is supplied with its own assembly instructions and hardware.

Step 1

Attach the headboard assembly to the metal bed frame using JCB M6 X 1" (D), flat washer (E), and split washer (F) then tighten with Allen wrench (G) as shown below.

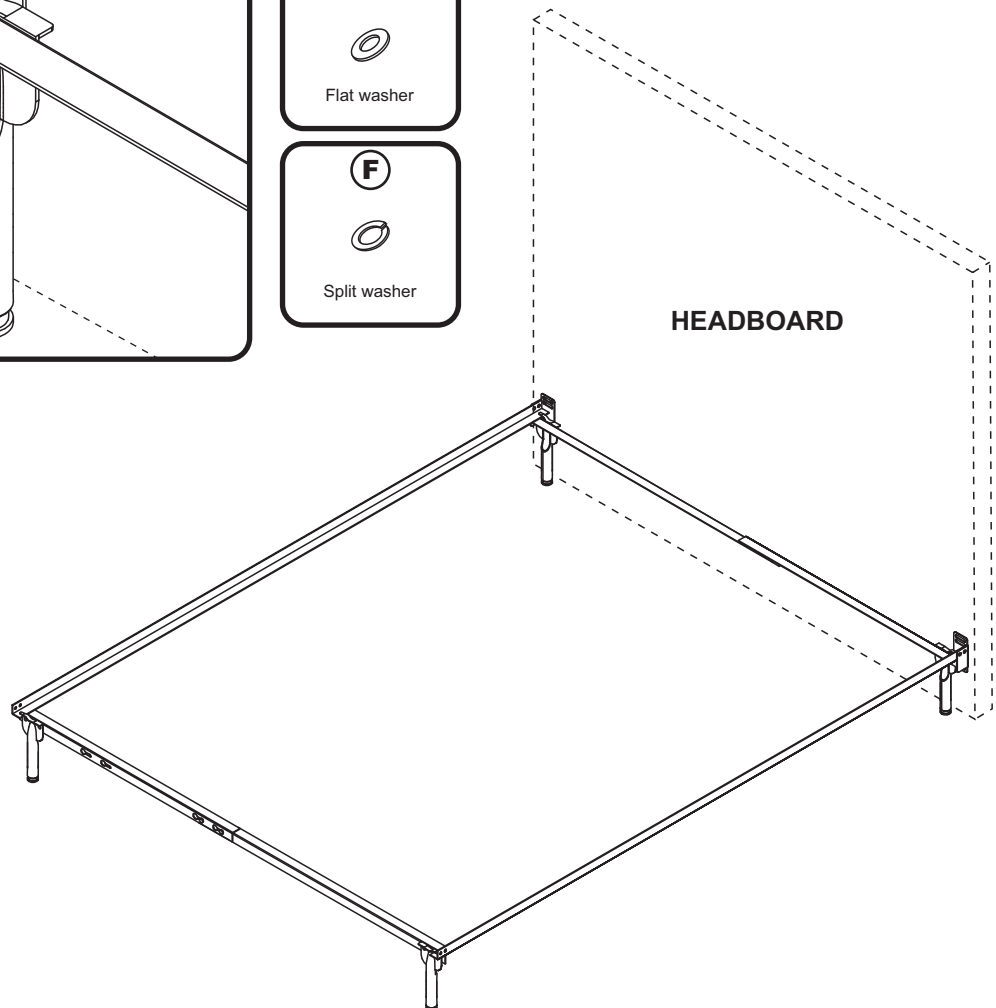
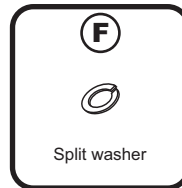
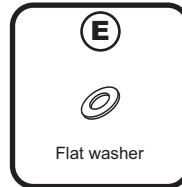
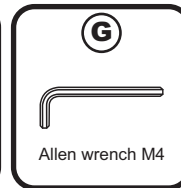
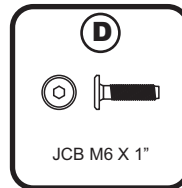
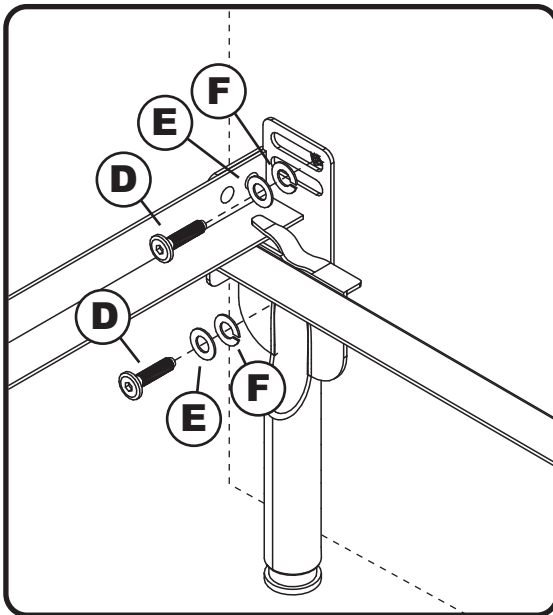

Congratulations!

Your bed is now ready for use.

To ensure lasting safety, we recommend that you periodically check that all screws are tight and all parts are secure.