

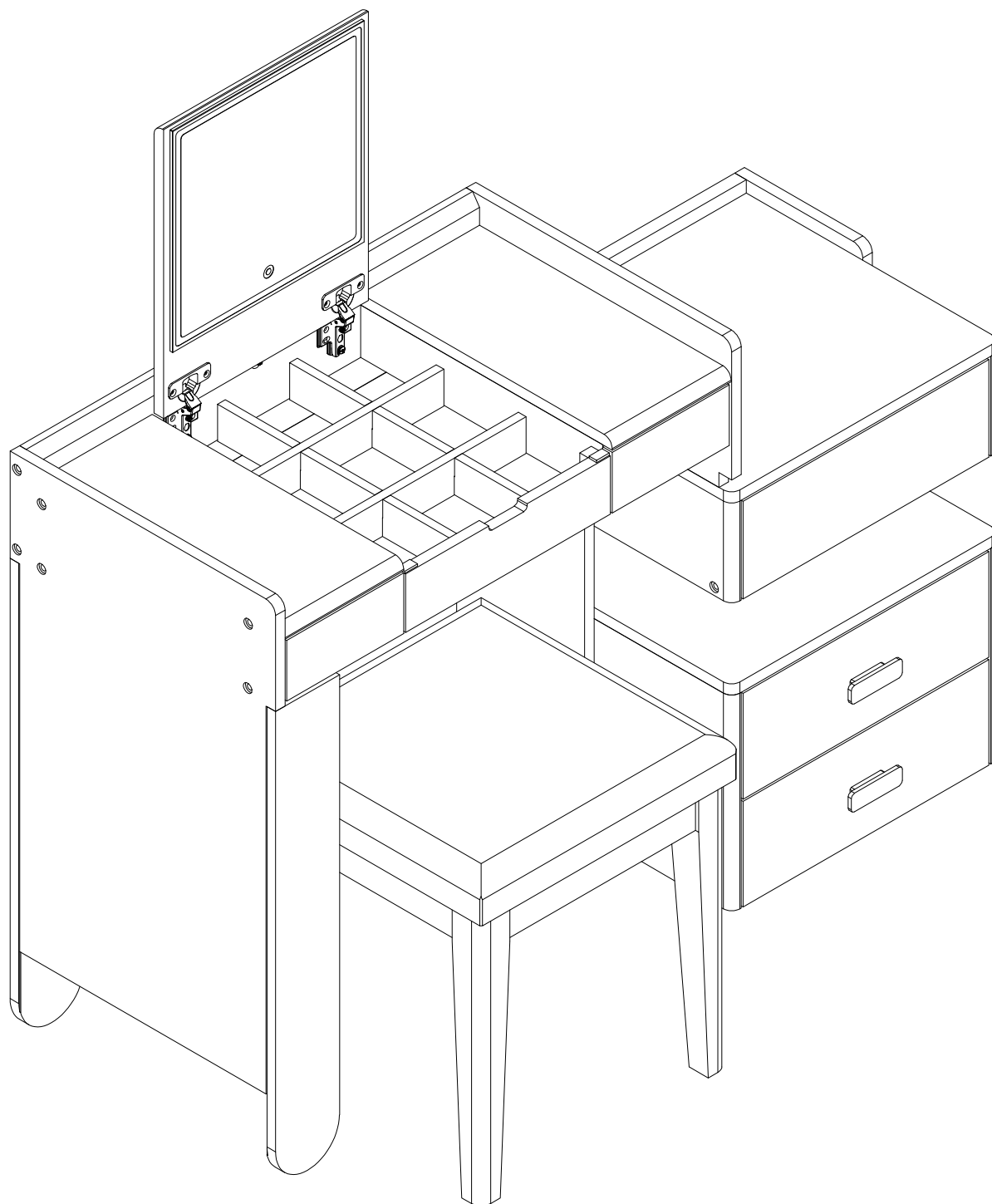

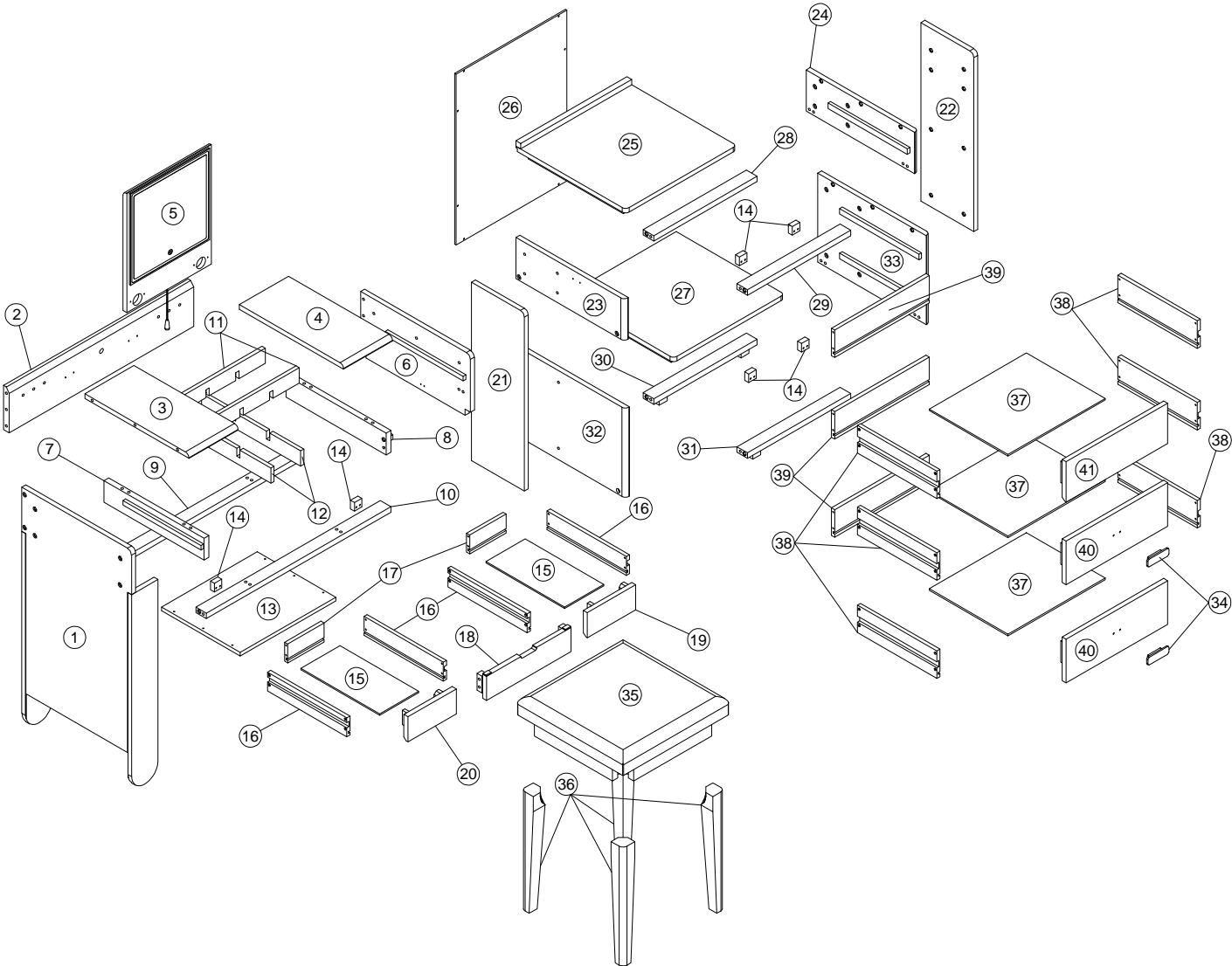







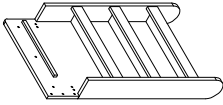
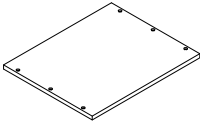
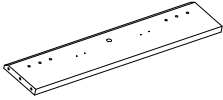

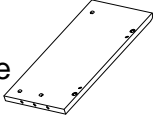

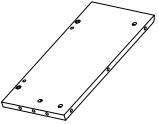
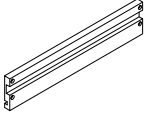
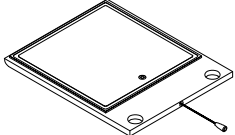
# Makeup Vanity Desk with Touch Light and Stool

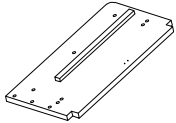
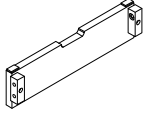
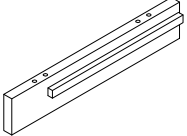
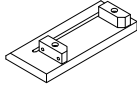
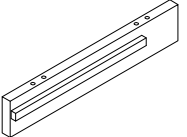
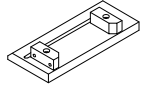

# PRODUCT DETAILS

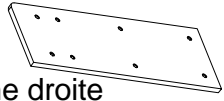
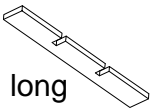

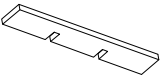





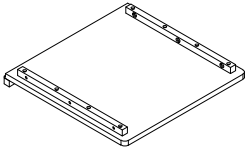
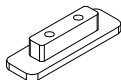
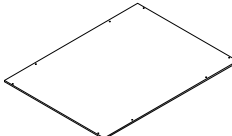
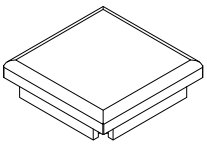
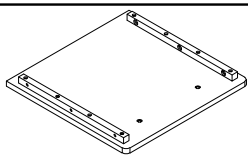
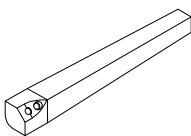
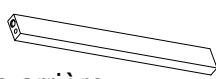
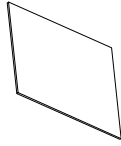
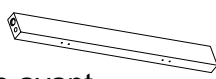
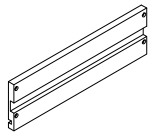
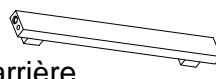
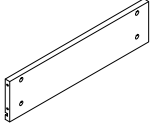
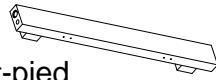
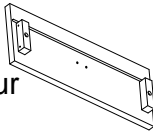
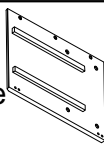
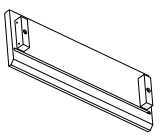
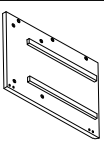





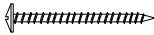







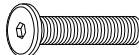

# PARTS LIST-LISTE DES PIECES

①	Left hip Hanche gauche		1pc	⑬	Bottom board Planche inférieure		1pc
②	Back board Panneau arrière		1pc	⑭	drawer stopper butée de tiroir		6pcs
③	Left side board Panneau latéral gauche		1pc	⑮	Drawer bottom board Planche de fond de tiroir		2pcs
④	Right side board Panneau latéral droit		1pc	⑯	Drawer door Porte de tiroir		4pcs
⑤	Middle board Plateau central		1pc	⑰	drawer back arrière du tiroir		2pcs
⑥	Right side panel Panneau latéral droit		1pc	⑱	Middle drawer face Façade du tiroir central		1pc
⑦	Left armrest Accoudoir gauche		1pc	⑲	Right drawer side Côté droit du tiroir		1pc
⑧	Right rail support Support de rail droit		1pc	⑳	Left drawer side Côté gauche du tiroir		1pc
⑨	Rear crossbar Barre transversale arrière		1pc	㉑	Left hip board Planche de hanche gauche		1pc
⑩	Front crossbar Barre transversale avant		1pc	㉒	Right hip board Planche de hanche droite		1pc
⑪	Long partition board Panneau de séparation long		2pcs	㉓	Upper left hip Hanche supérieure gauche		1pc
⑫	Short plank Planche courte		2pcs	㉔	Upper right hip Hanche supérieure droite		1pc

# PARTS LIST-LISTE DES PIÈCES

25	Top Roof Toit supérieur		1pc	34	Drawer Handles Poignées de tiroir		2pcs
26	Backboard Panneau		1pc	35	Chair seat Siège de chaise		1pc
27	Lower roof Toit inférieur		1pc	36	Chair legs Pieds de chaise		4pcs
28	Rear crossbar Barre transversale arrière		1pc	37	Drawer bottom board Planche de fond de tiroir		3pc
29	Front crossbar Barre transversale avant		1pc	38	Drawer door Porte de tiroir		6pcs
30	Rear foot sole Semelle du pied arrière		1pc	39	drawer back arrière du tiroir		3pcs
31	Forefoot sole Semelle de l'avant-pied		1pc	40	Bottom drawer face Façade du tiroir inférieur		2pcs
32	Upper left hip Hanche supérieure gauche		1pc	41	Top drawer Tiroir supérieur		1pc
33	Upper right hip Hanche supérieure droite		1pc				

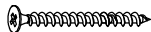
# HARDWARE LIST-LISTE DU MATÉRIEL

(A)	Anti Tip Kit 1 set		4PCS	(N)	Ø 10*10mm		20pcs
(B)			2PCS	(O)	M4*20mm		4pcs
(C)			2PCS	(P)	3.5*15mm		12pcs
(D)			2PCS	(Q)	Ø 35mm		2pcs
(E)			2PCS	(R)	Ø1*19mm		8pcs
(F)	M6X50mm		10pcs	(S)	M6*60mm		8pcs
(G)	M4*25mm		38psc	(T)	Ø11*1mm		8pcs
(H)	3.5*15mm		11pcs	(U)	Ø8X30mm		30PCS
(I)			1pc	(V)	L4*58mm		1pc
(K)	M6X20mm		16PCS	(W)	M6X50mm		6pcs
(L)			1pc	(X)	M6X25mm		14pcs
(M)	M4*50mm		20pcs	(Y)	M6X30mm		16pcs

ASSEMBLY TOOLS REQUIRED (NOT INCLUDED)  
 OUTILS D'ASSEMBLAGE REQUIS (NON INCLUS)

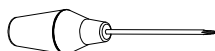

# Step 1

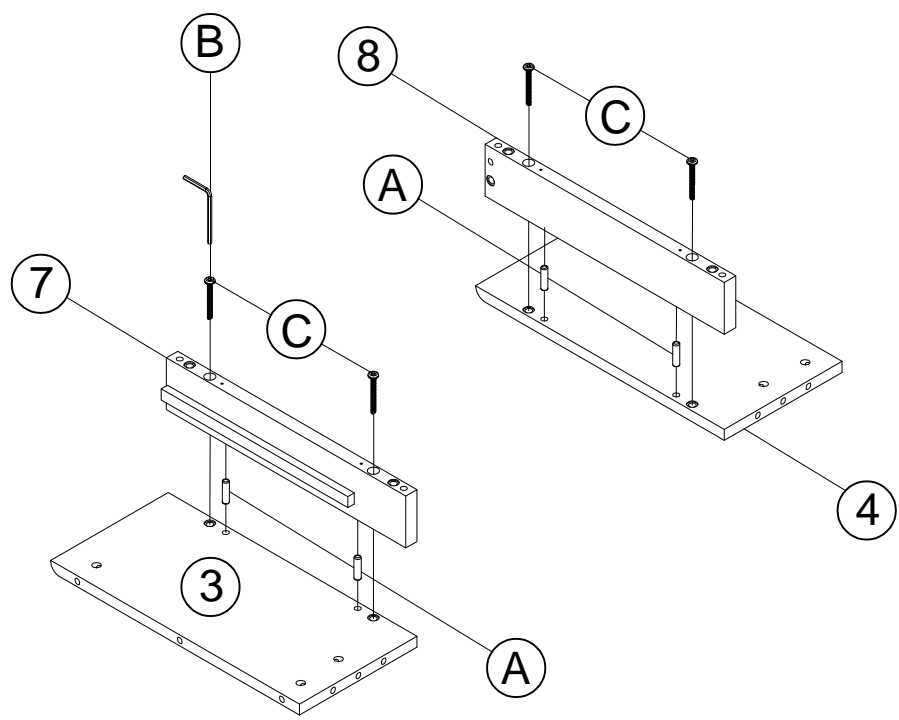

U	Ø8X30mm		4PCS
V	L4*58mm		1PC

W	M6X50mm		4PCS
---	---------	--	------

# Step 2

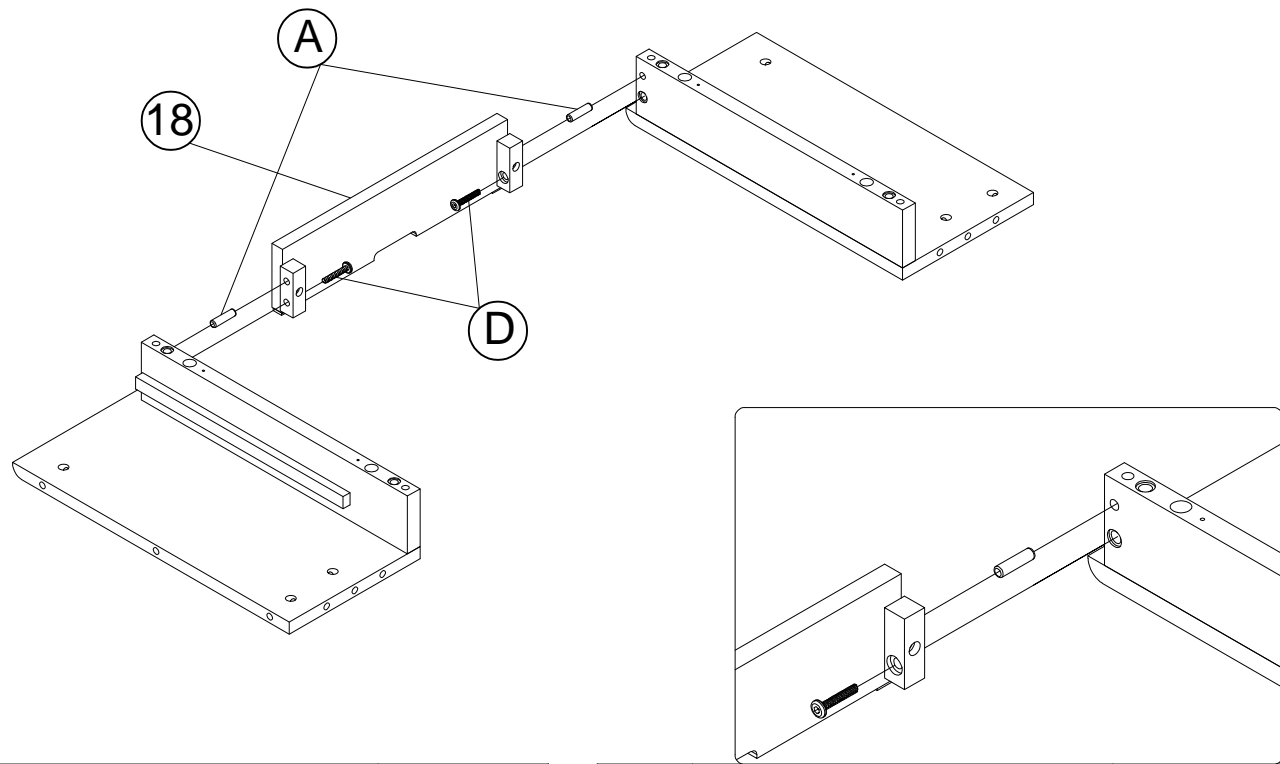



U	Ø8X30mm		2PCS
---	---------	--	------

X	M6X25mm		2PCS
---	---------	--	------

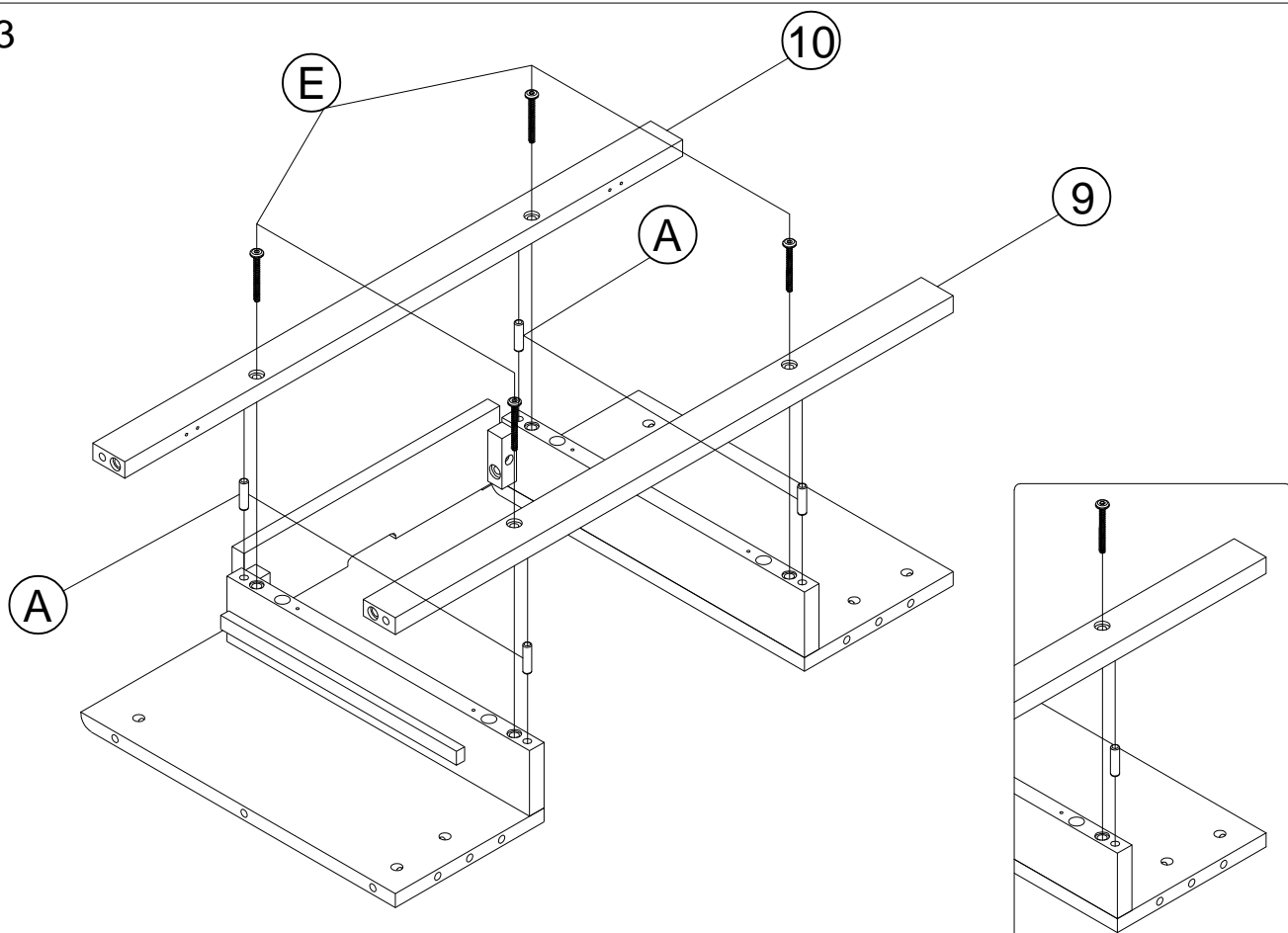
### Step 3



	Ø8X30mm	4PCS
--	---------	------

	M6X30mm	4PCS
---	---------	------

### Step 4

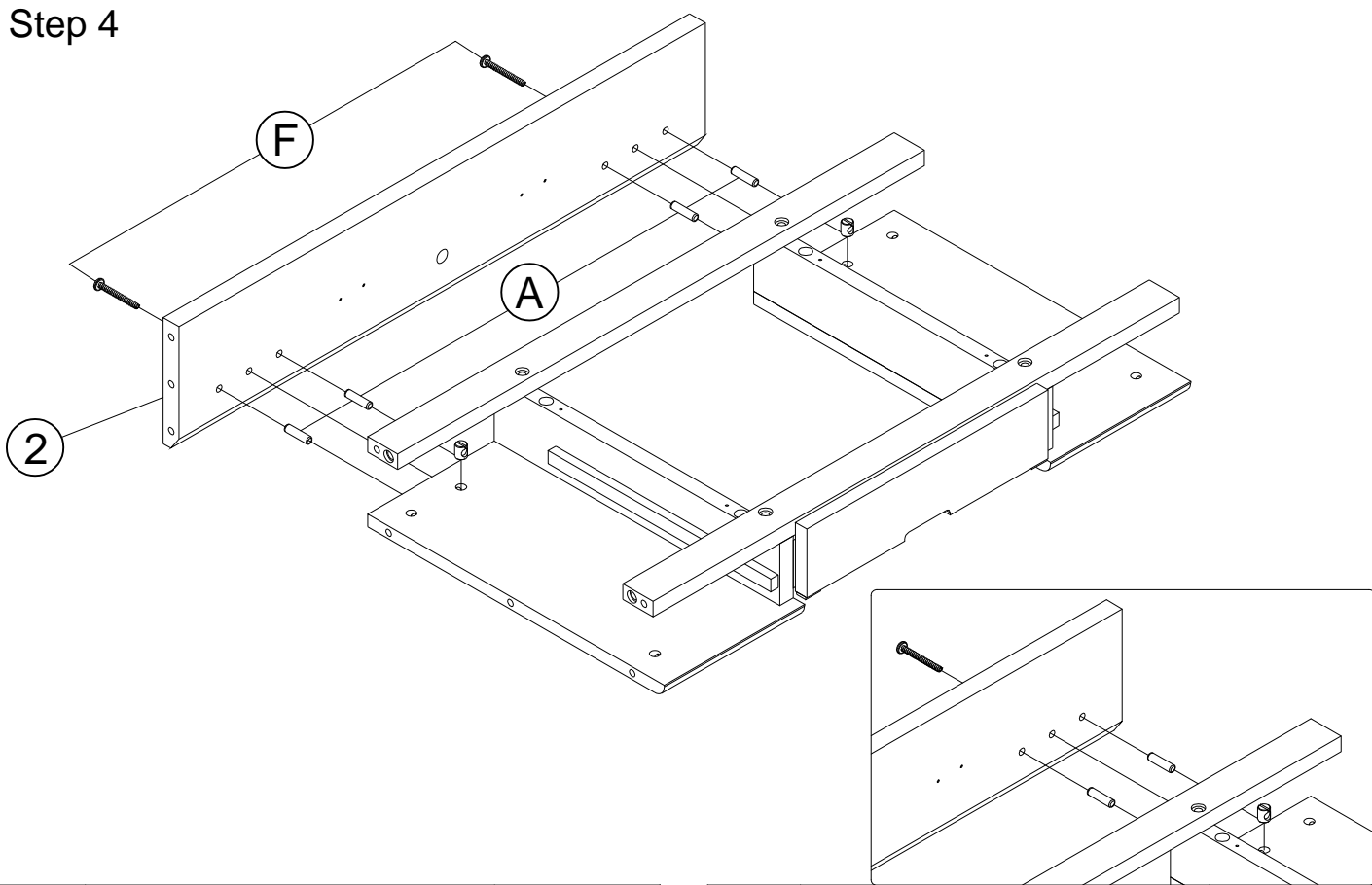

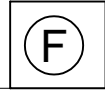

	Ø8X30mm	4PCS
--	---------	------

	M6X50mm	2PCS
---	---------	------

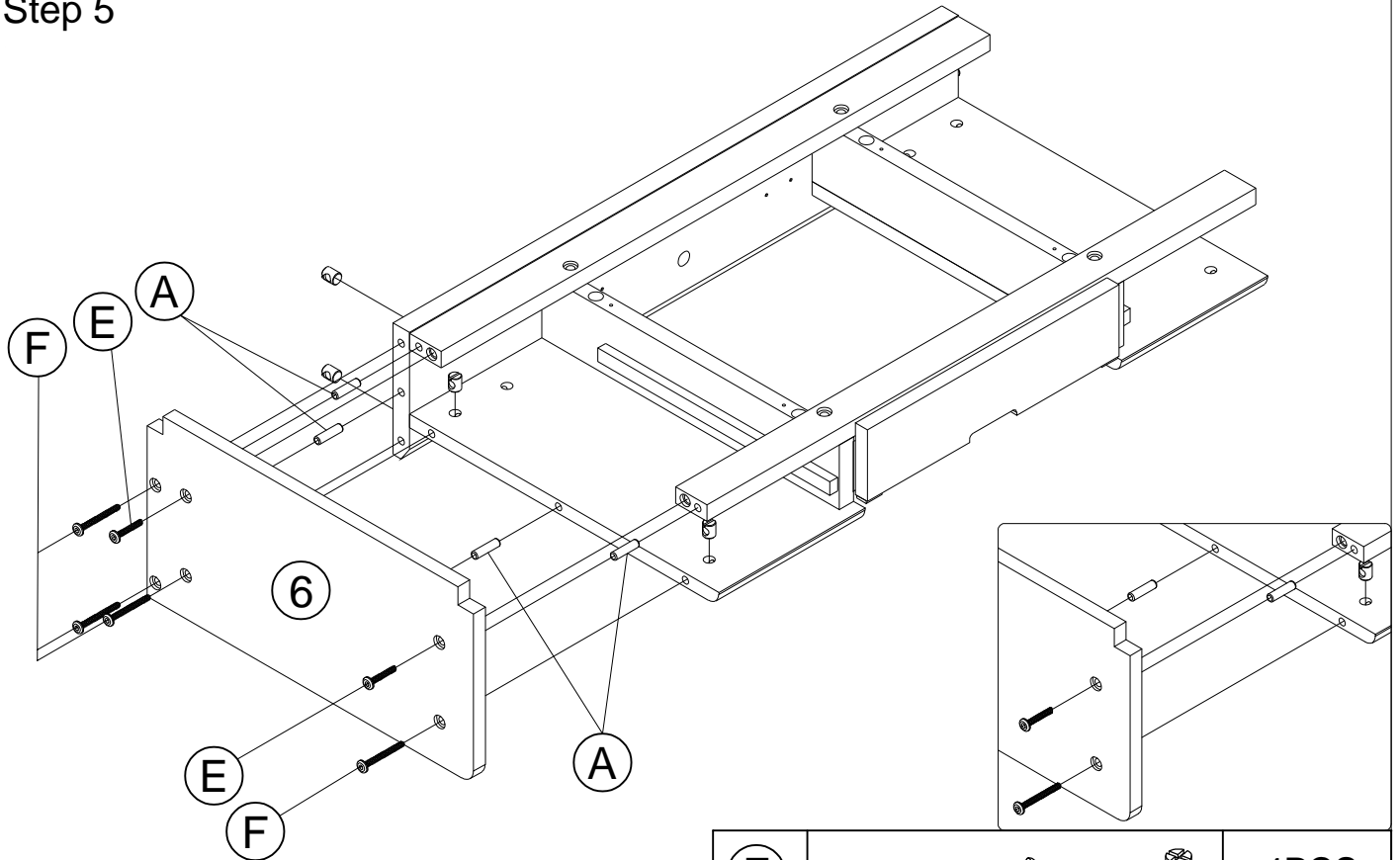
### Step 5



ⓕ	M6X50mm		4PCS
Ⓨ	M6X30mm		2PCS

Ⓢ	Ø8X30mm		4PCS
---	---------	---	------

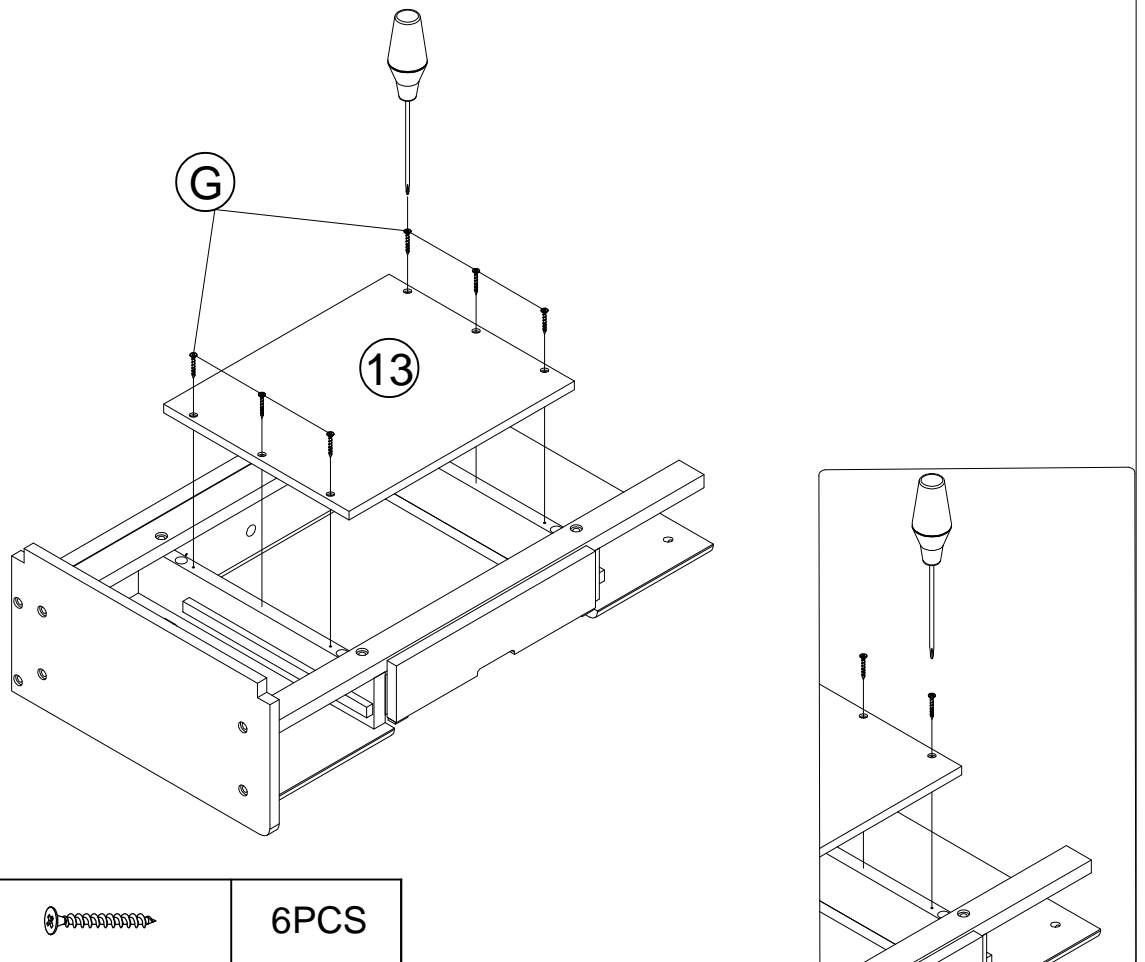

### Step 6

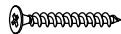

ⓖ	M4*25mm		6PCS
---	---------	---	------

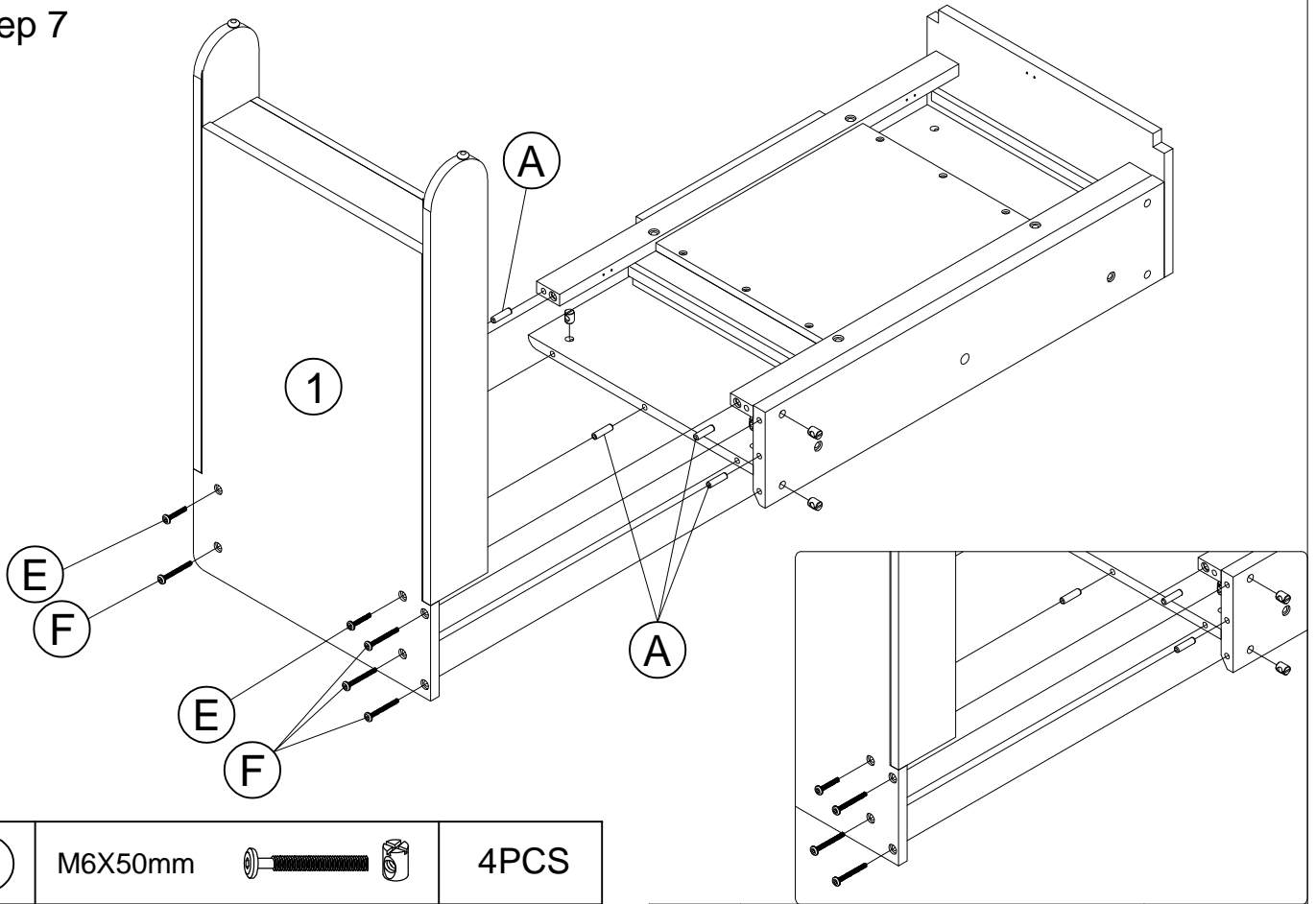
### Step 7



(F)	M6X50mm		4PCS
(U)	Ø8X30mm		4PCS

(Y)	M6X30mm		2PCS
-----	---------	---	------

### Step 8

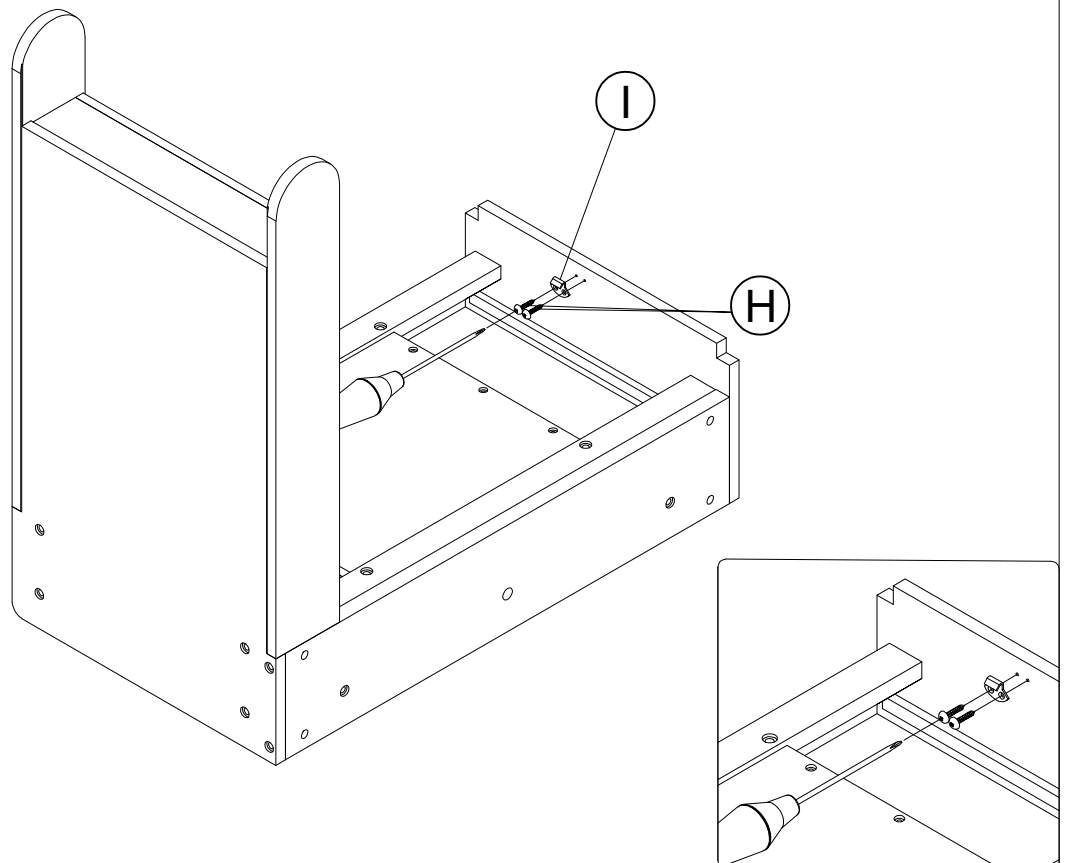



(H)	3.5*15mm		2PCS
-----	----------	---	------

(I)			1PCS
-----	--	---	------

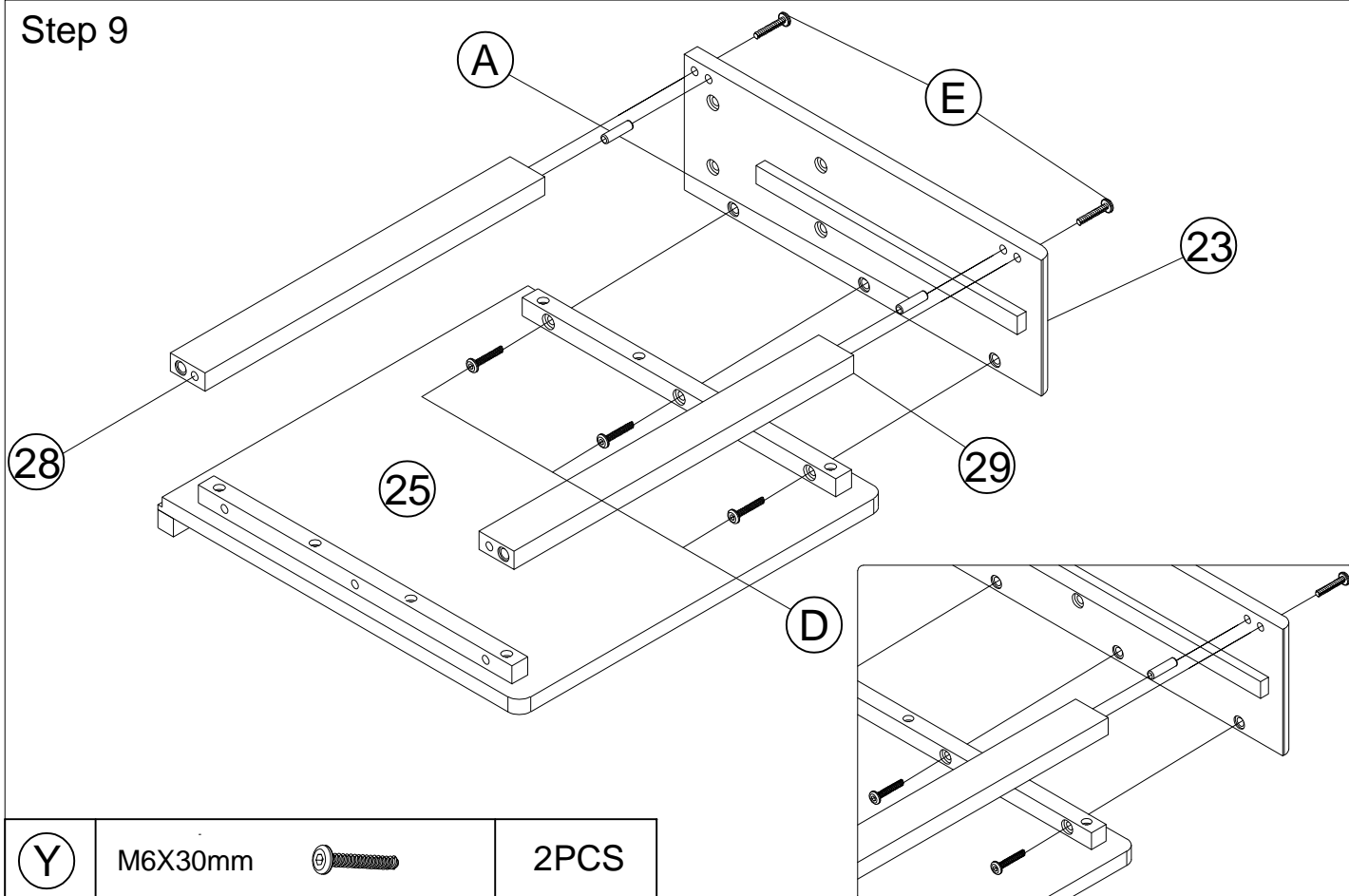
### Step 9





Y	M6X30mm		2PCS
X	M6X25mm		3PCS

U	Ø8X30mm		2PCS
---	---------	---	------

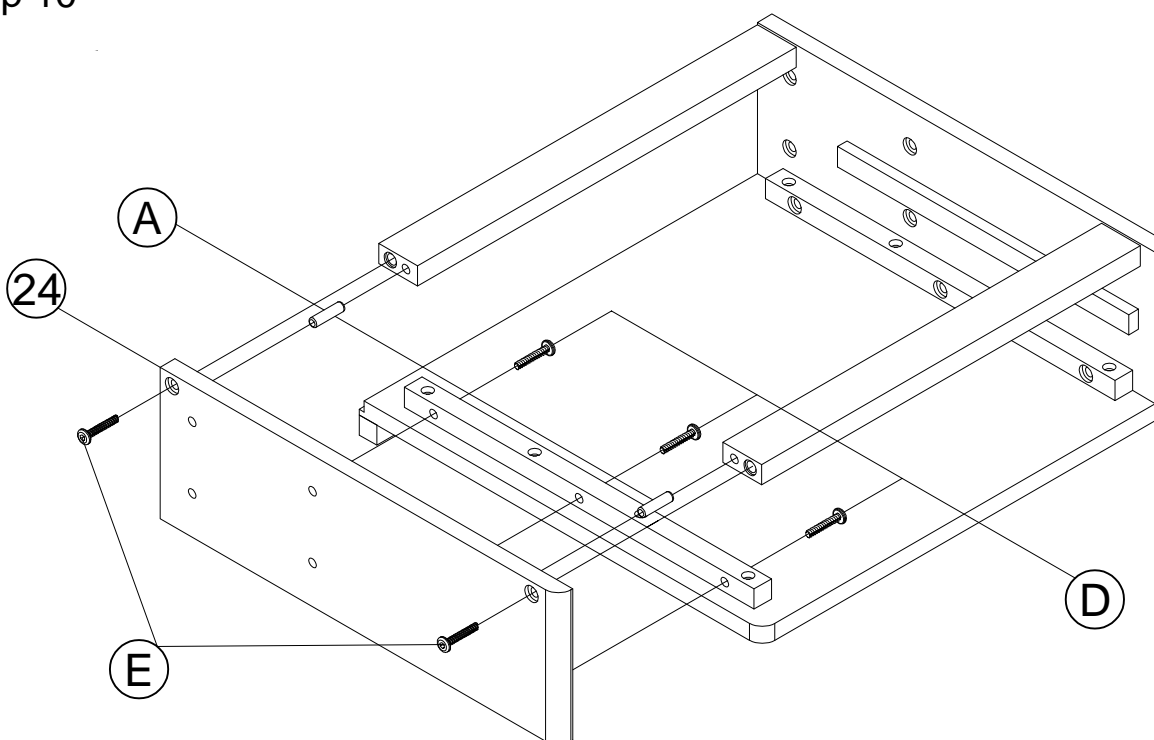
### Step 10





Y	M6X30mm		2PCS
X	M6X25mm		3PCS

U	Ø8X30mm		2PCS
---	---------	---	------

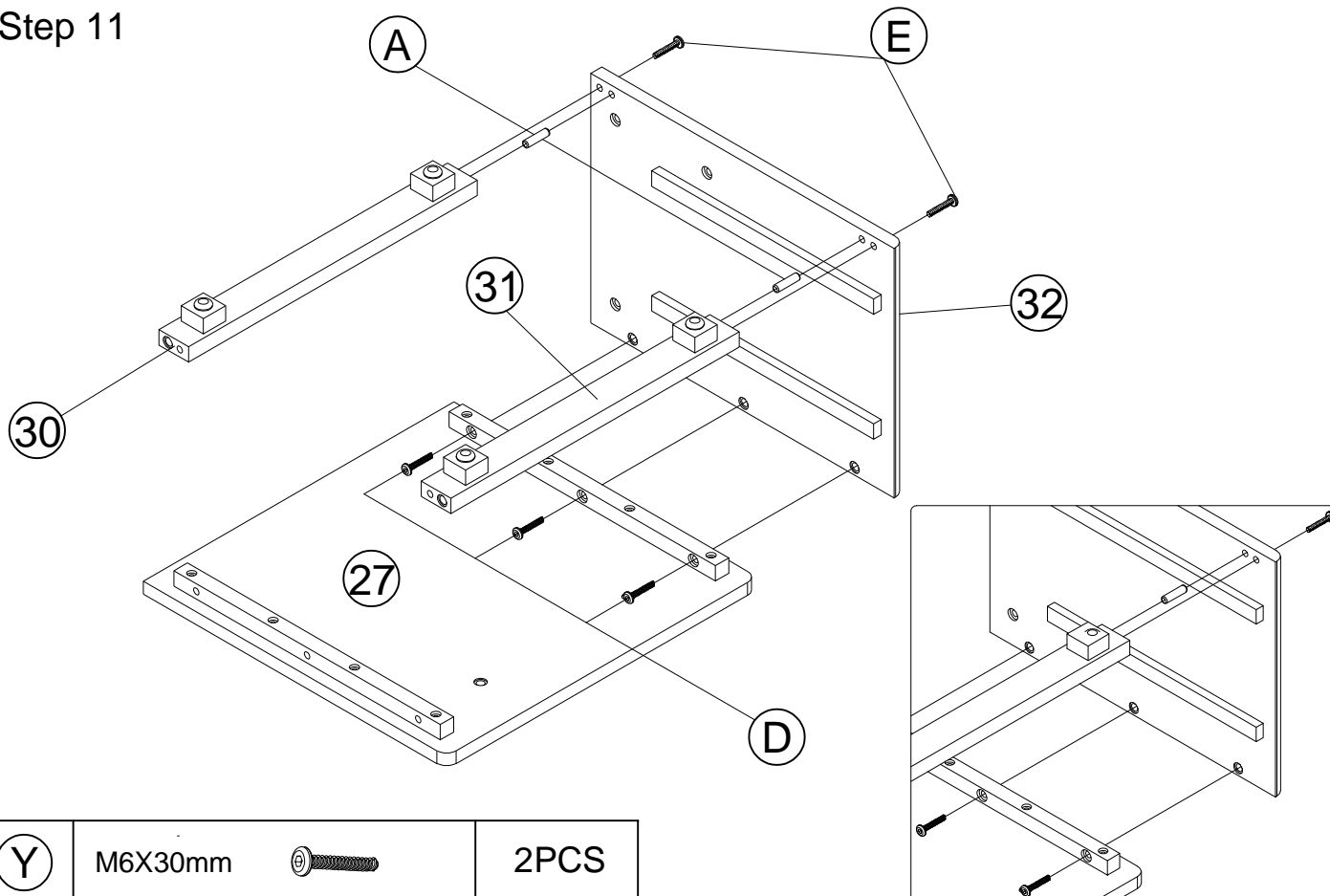
### Step 11





Y	M6X30mm		2PCS
X	M6X25mm		3PCS

U	Ø8X30mm		2PCS
---	---------	---	------

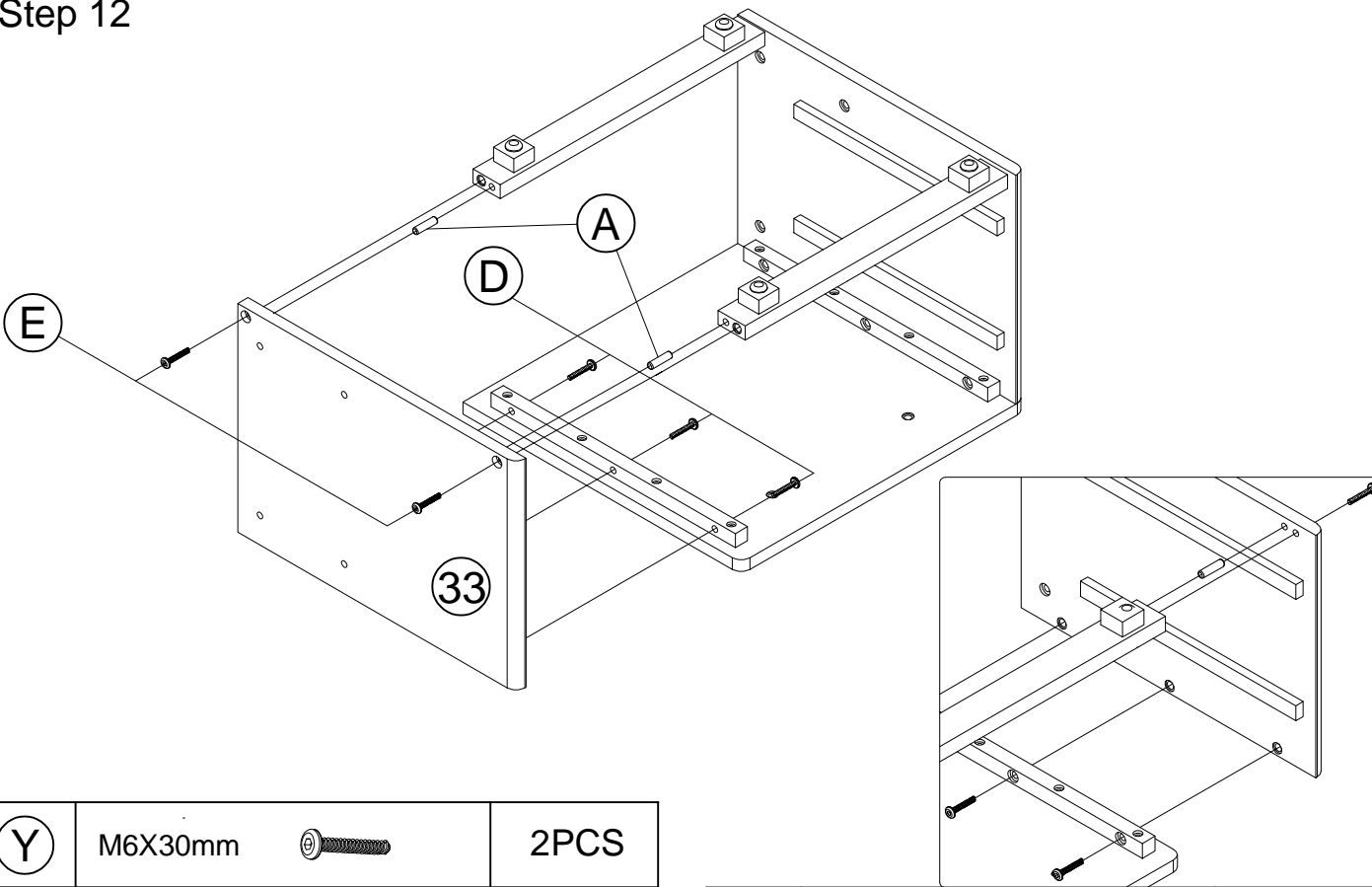
### Step 12



Y	M6X30mm		2PCS
X	M6X25mm		3PCS

U	Ø8X30mm		2PCS
---	---------	---	------

# Step 13

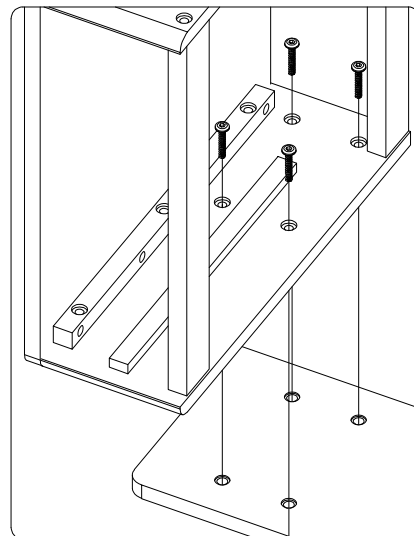
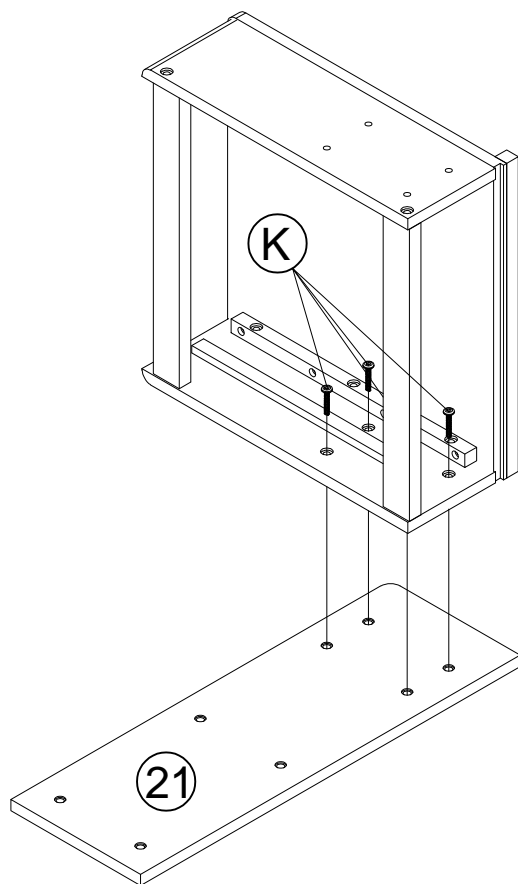

<b>(K)</b>	M6X20mm 	<b>4PCS</b>
------------	---	-------------

# Step 14

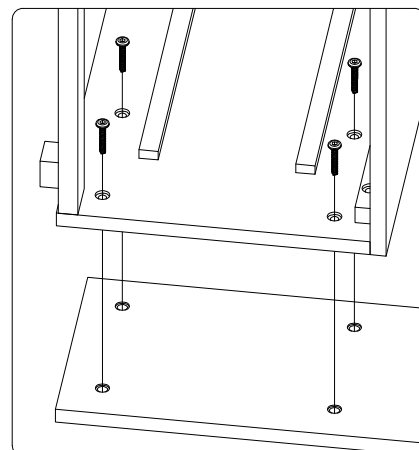
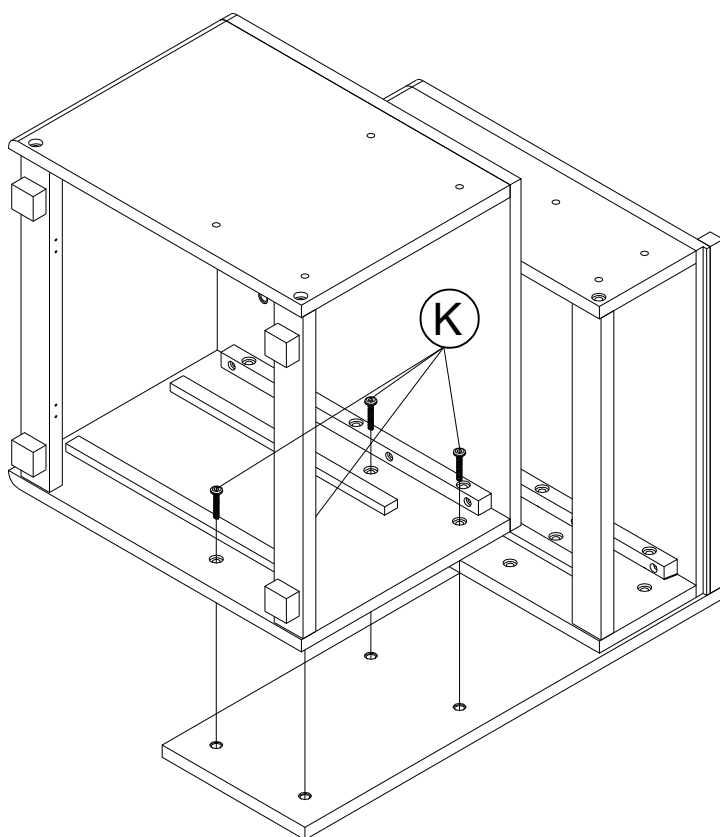

<b>(K)</b>	M6X20mm 	<b>4PCS</b>
------------	---	-------------

# Step 15

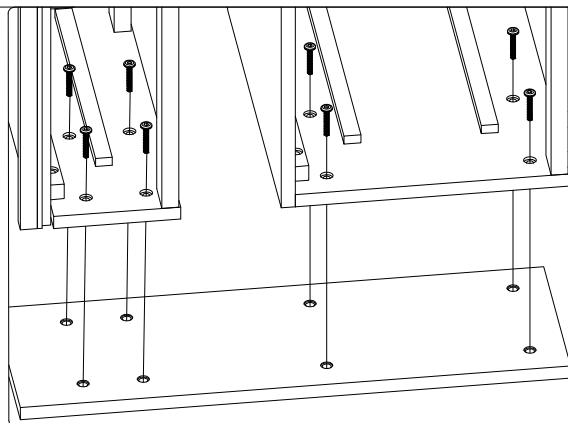
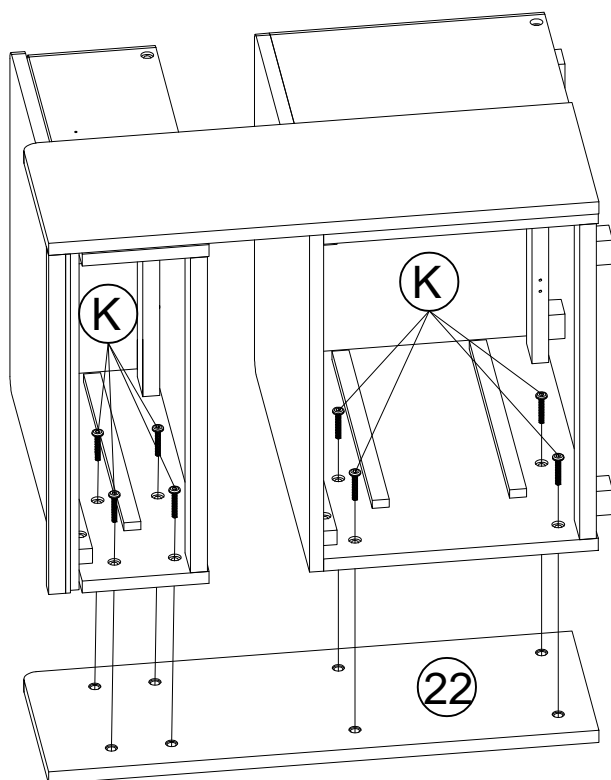

	M6X20mm		8PCS
--	---------	--	------

# Step 16

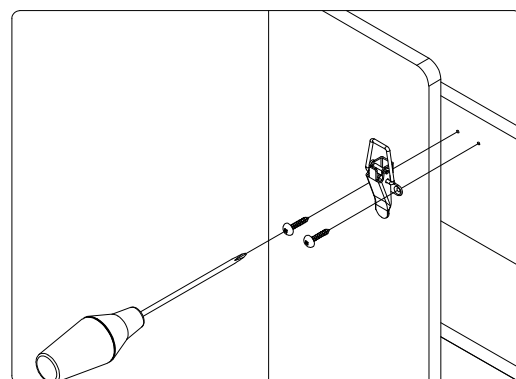
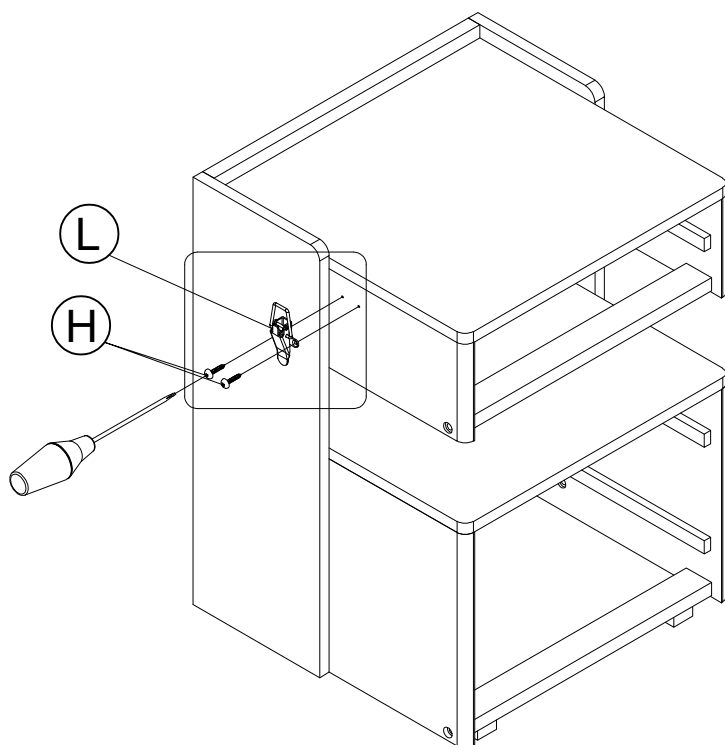

	3.5*15mm		2PCS			1PCS
--	----------	--	------	--	--	------

# Step 17

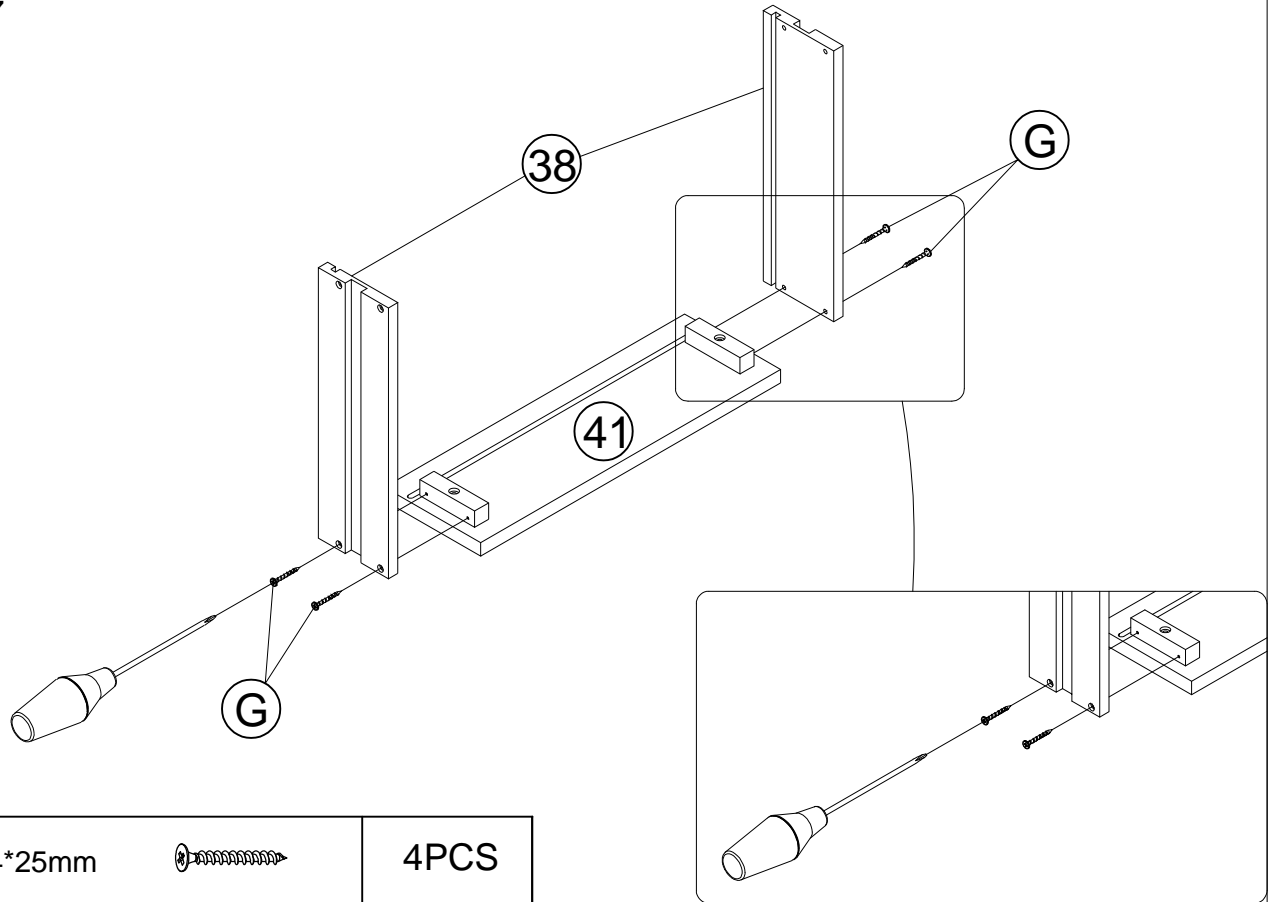

G	M4*25mm 	4PCS
---	---	------

# Step 18

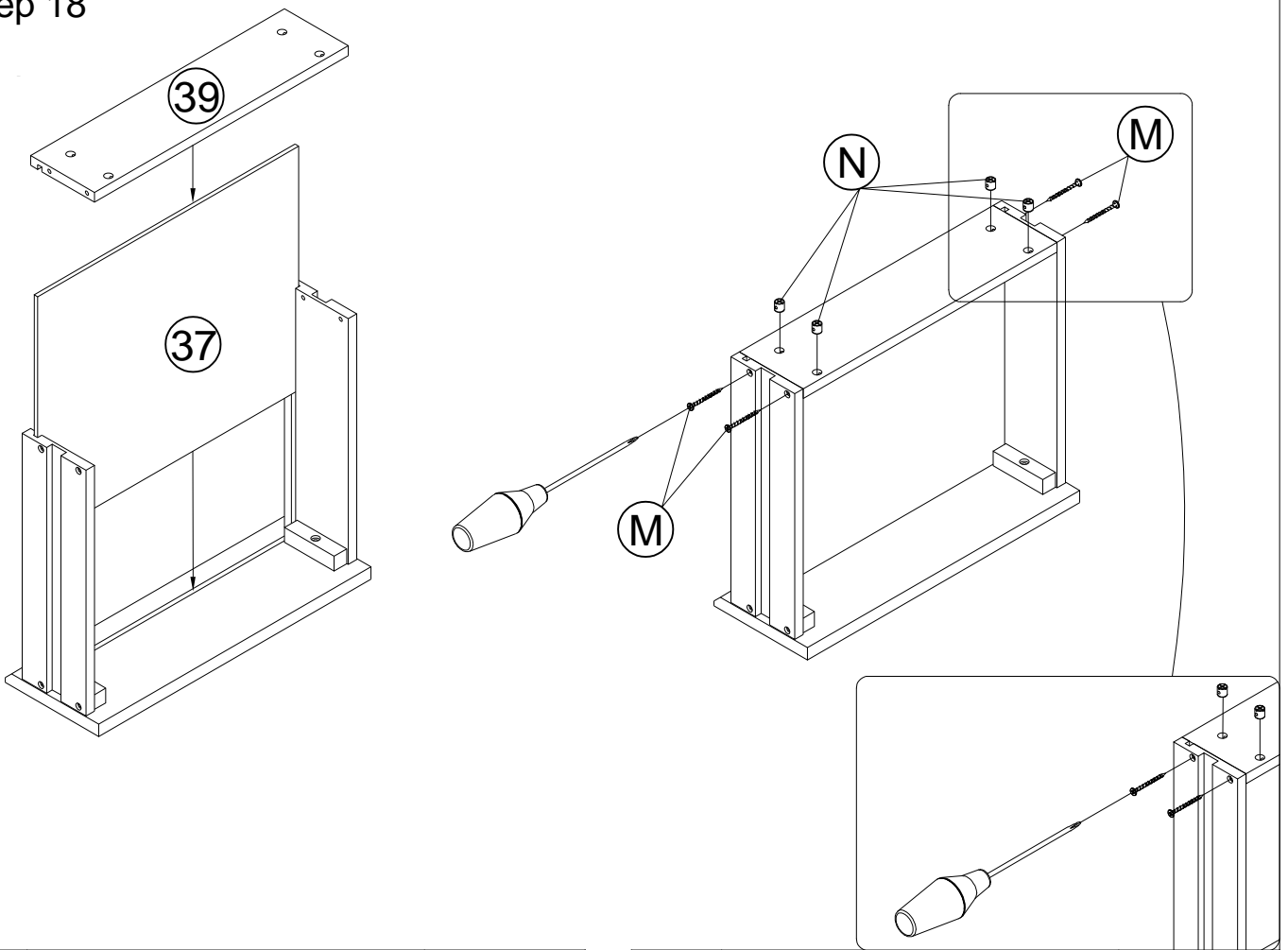

M	M4*50mm 	4PCS
---	---	------

N	Ø 10*10mm 	4PCS
---	---	------

# Step 19

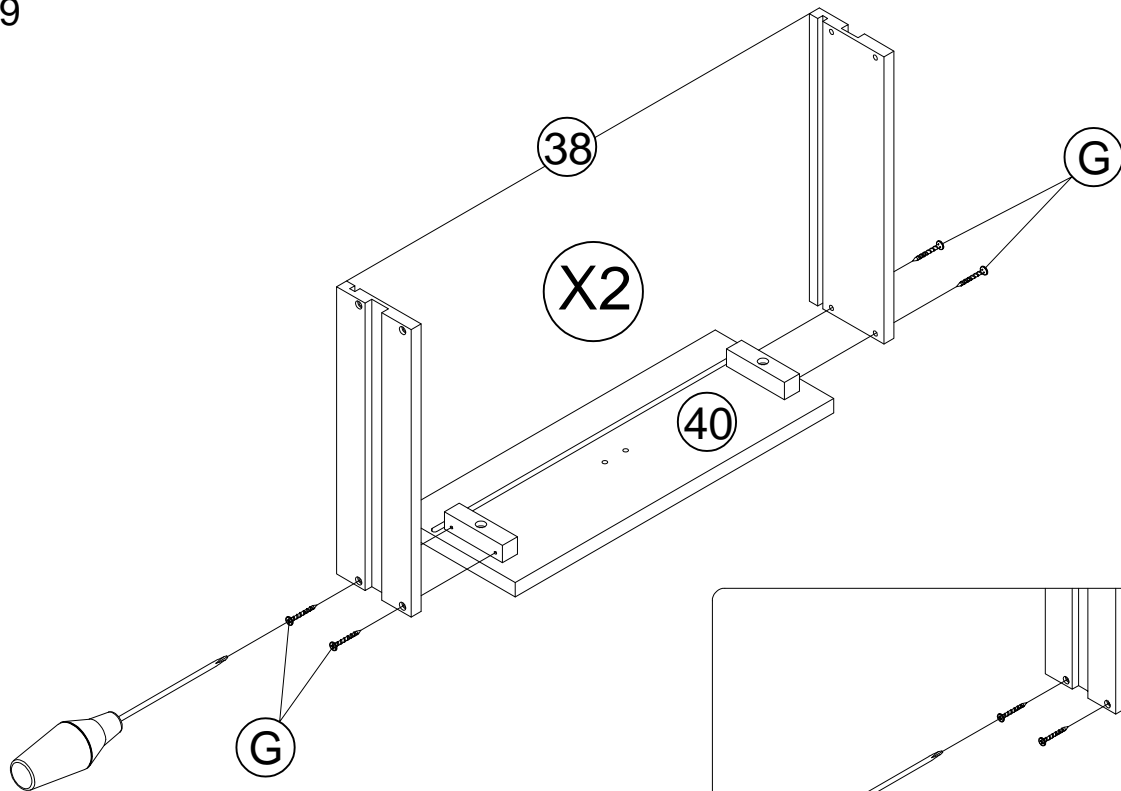

G	M4*25mm 	8PCS
---	---	------

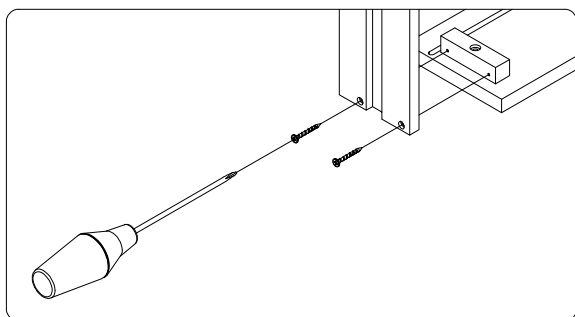

# Step 20

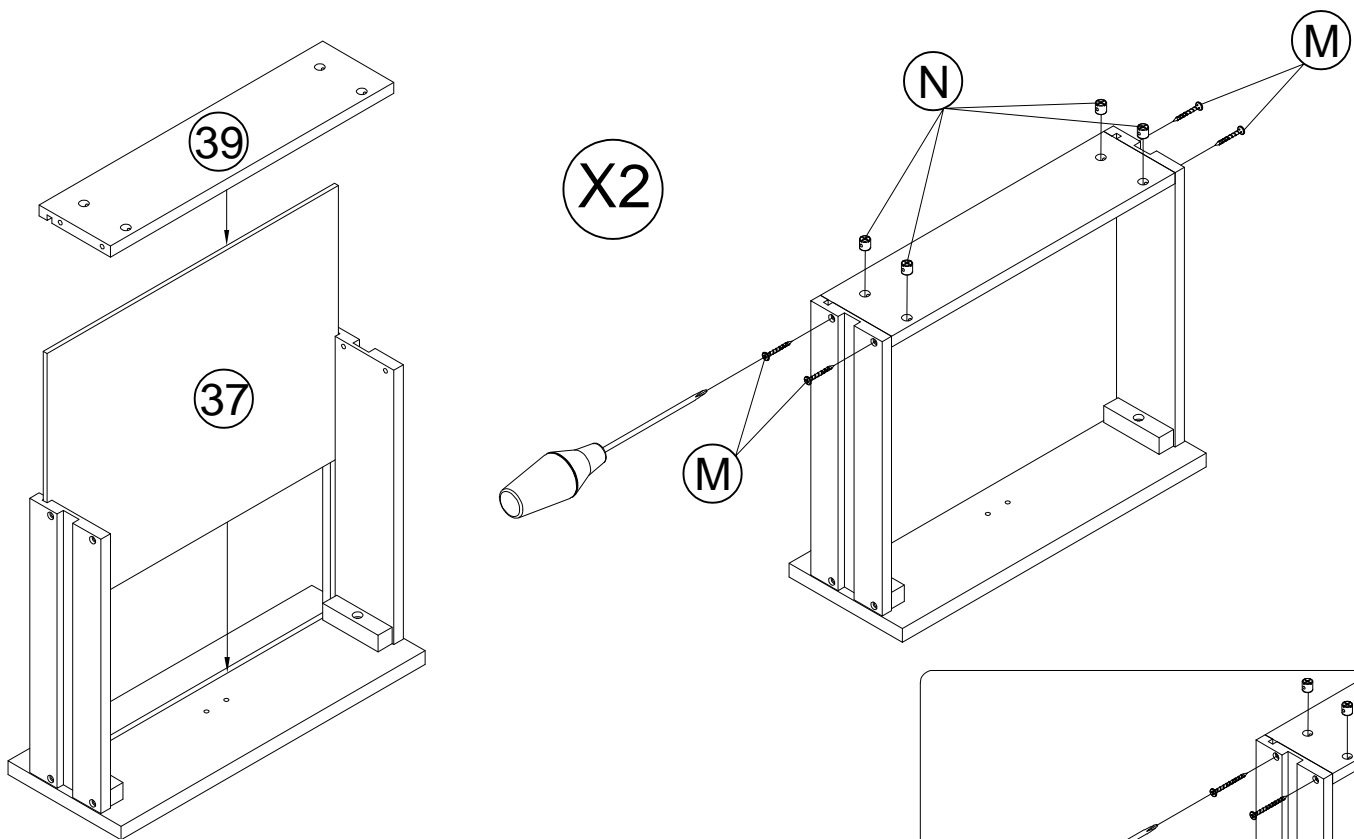

M	M4*50mm 	8PCS
---	---	------

N	Ø 10*10mm 	8PCS
---	---	------

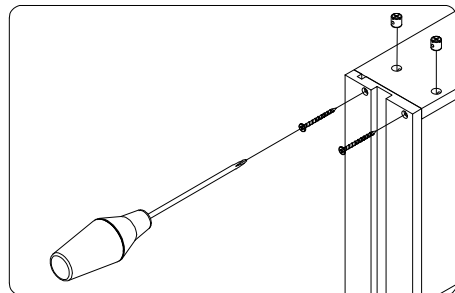

## Step 22

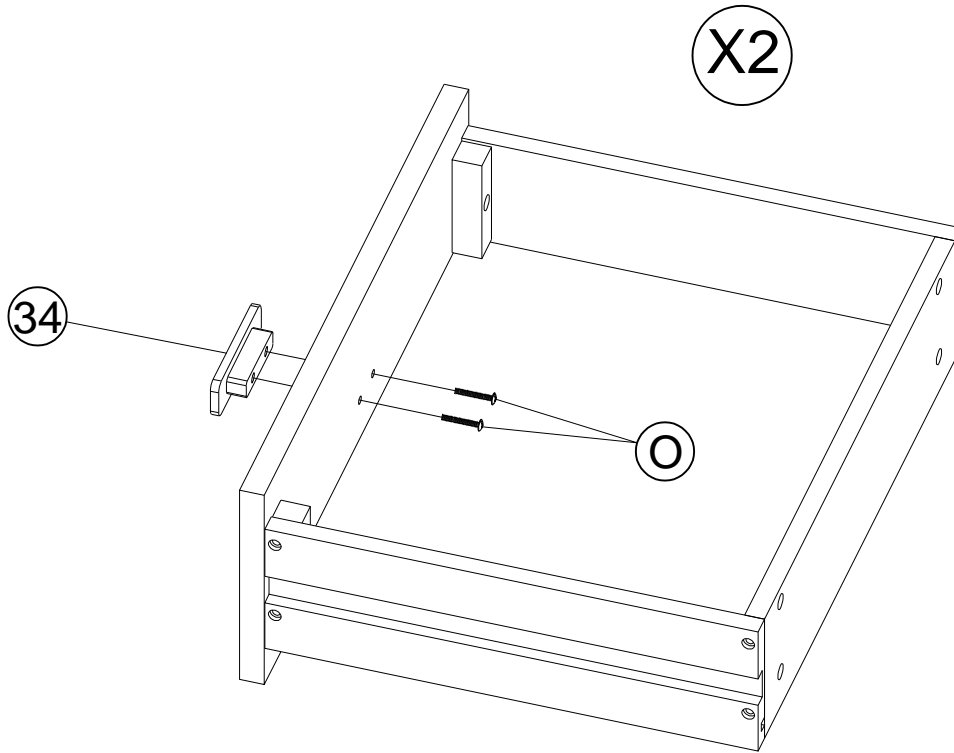

M4\*20mm



4PCS

## Step 23

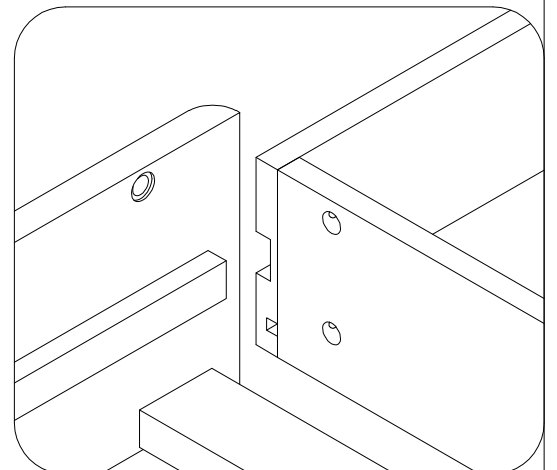
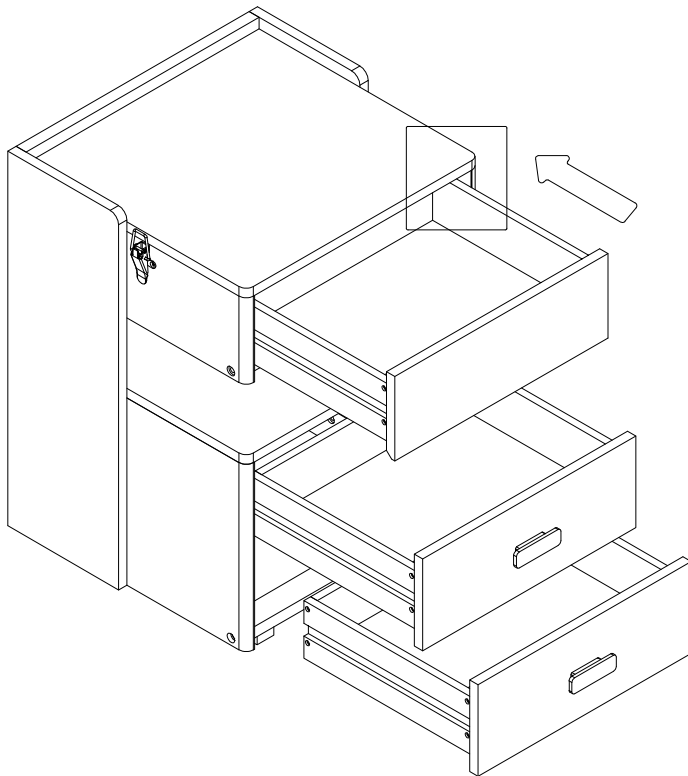

## Step 24

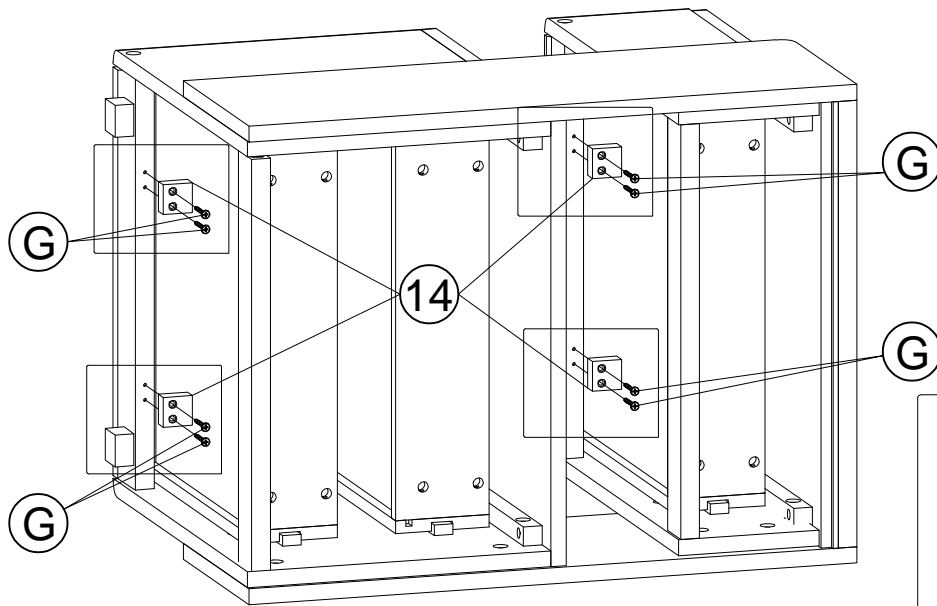

(G)

M4\*25mm

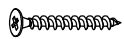

8PCS

## Step 25

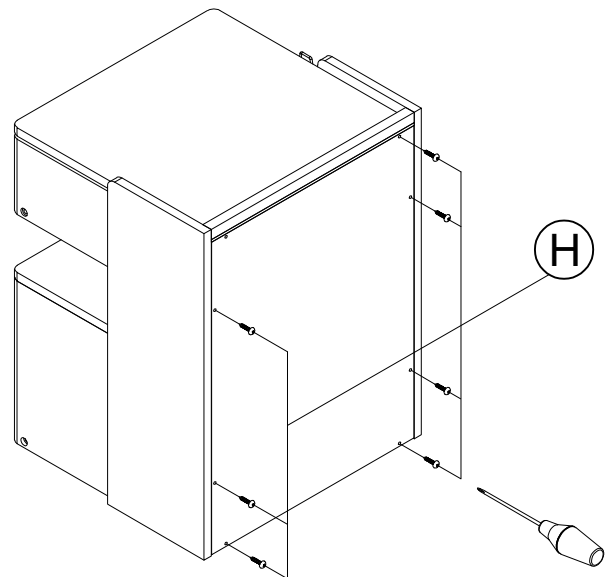
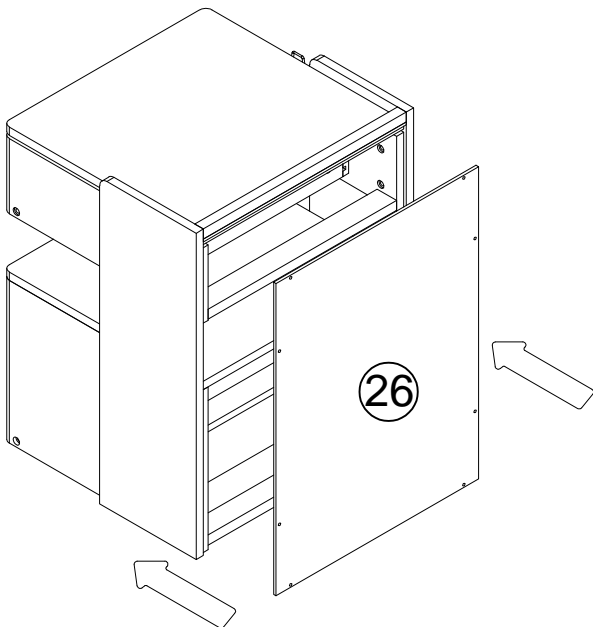

(H)

3.5\*15mm



7PCS

# Step 26

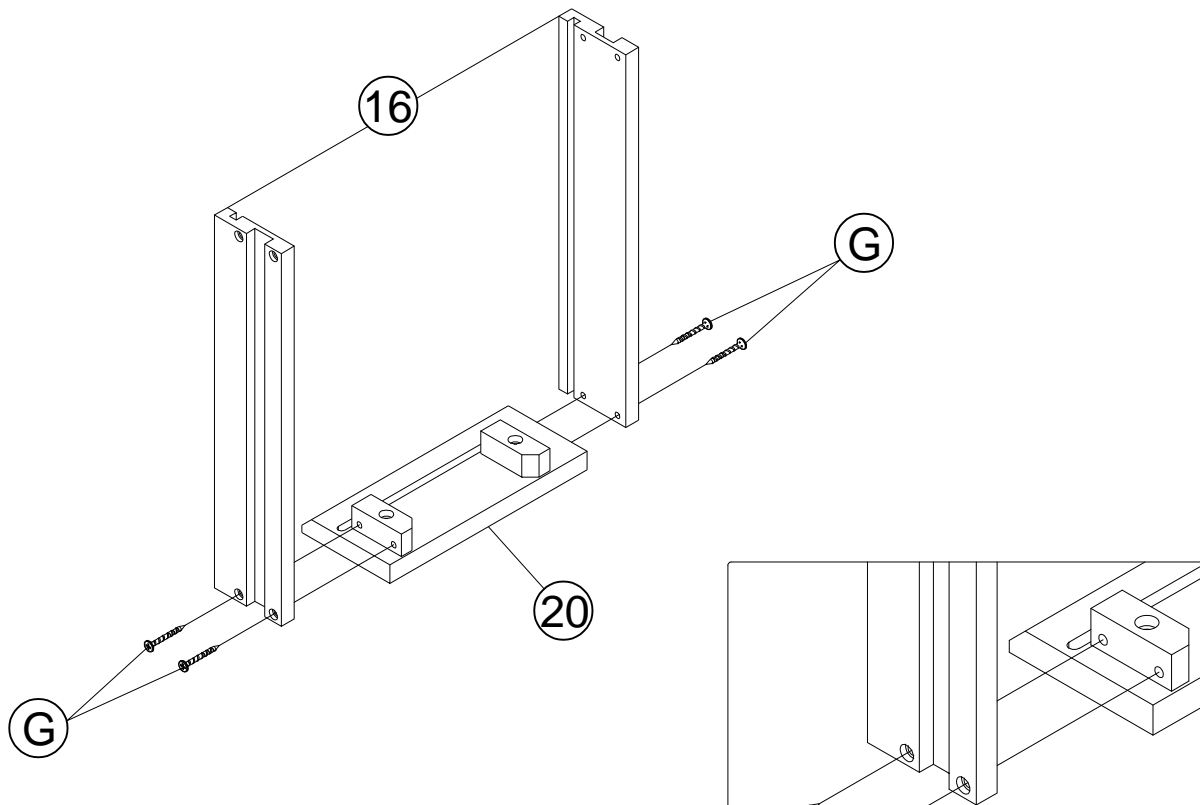

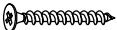

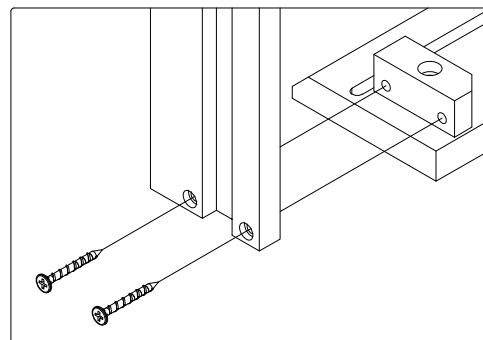
G	M4*25mm 	4PCS
---	---	------

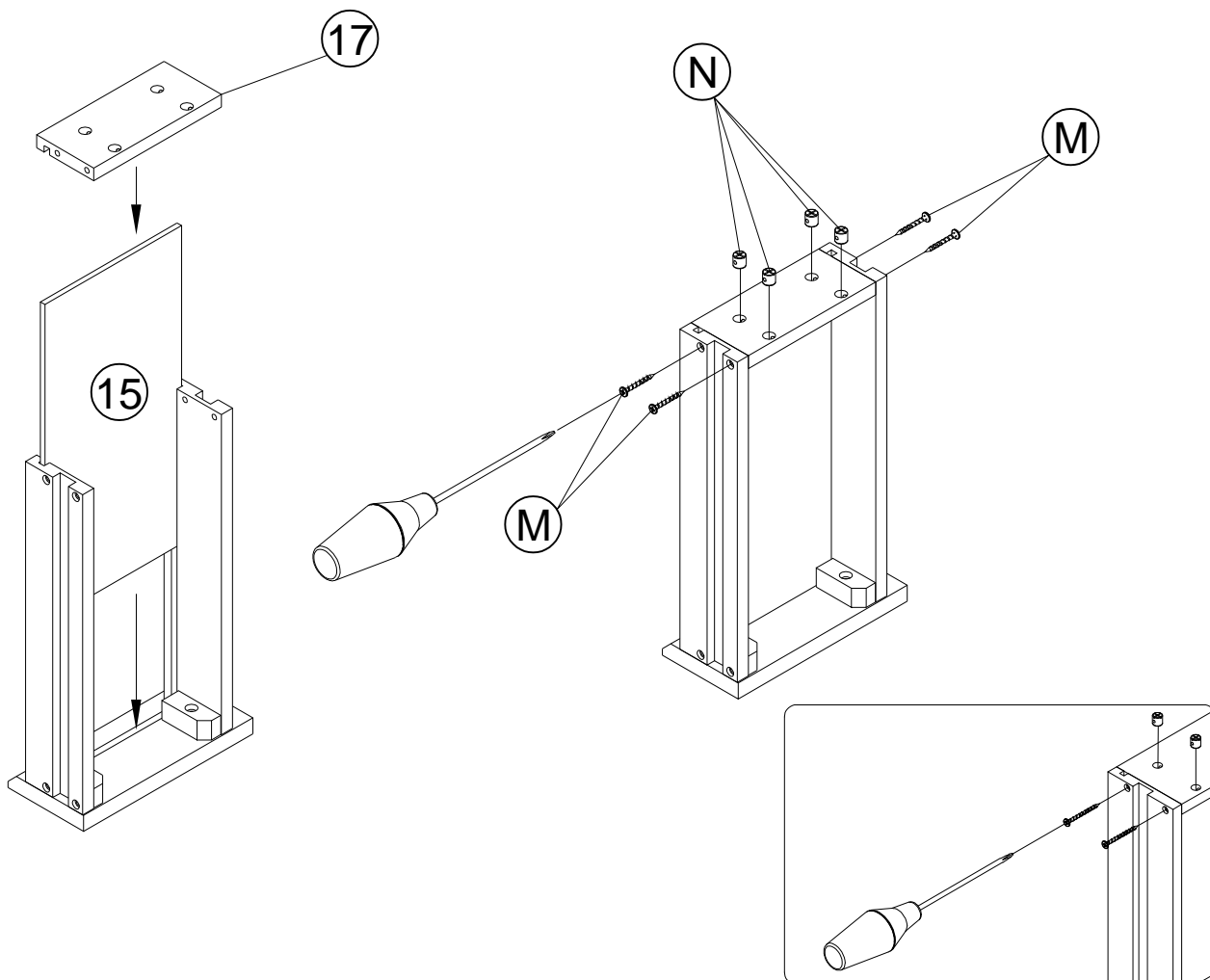

# Step 27

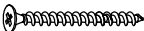

M	M4*50mm 	4PCS
---	---	------

N	Ø 10*10mm 	4PCS
---	---	------

### Step 28

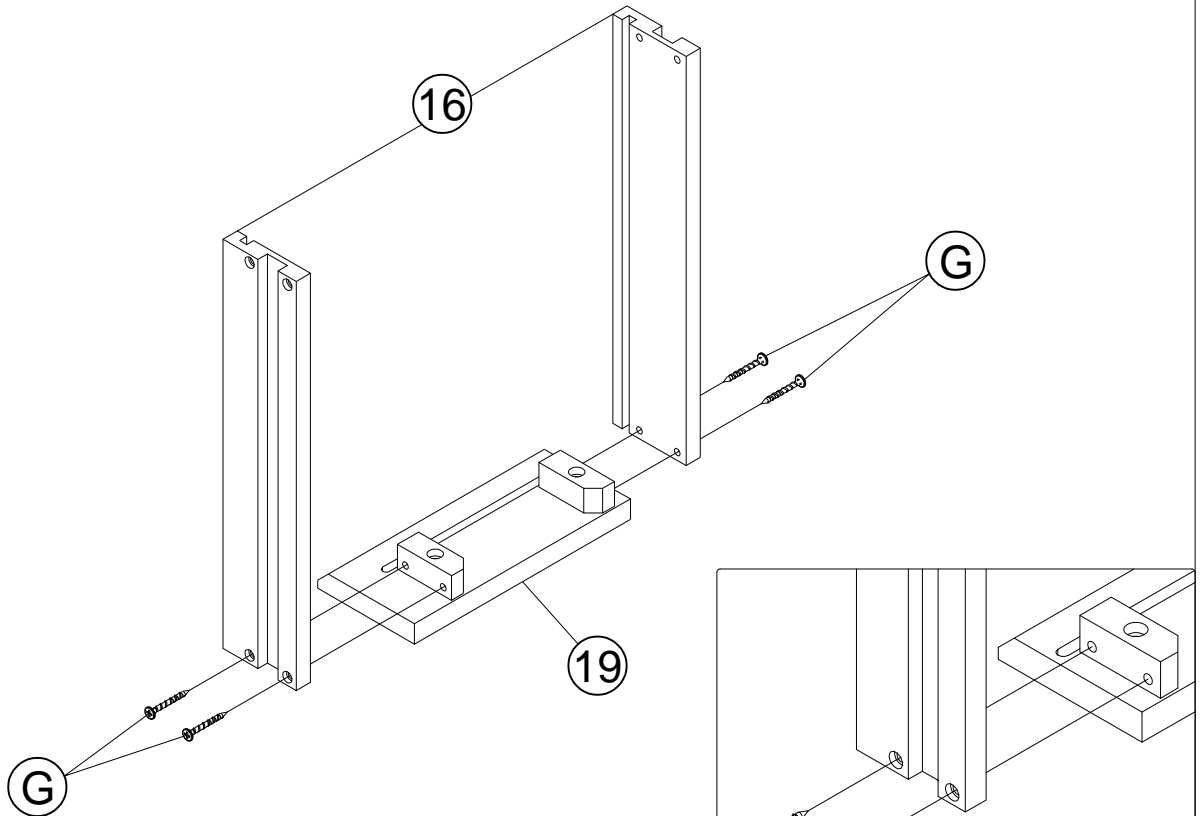

G	M4*25mm 	4PCS
---	---	------

### Step 29

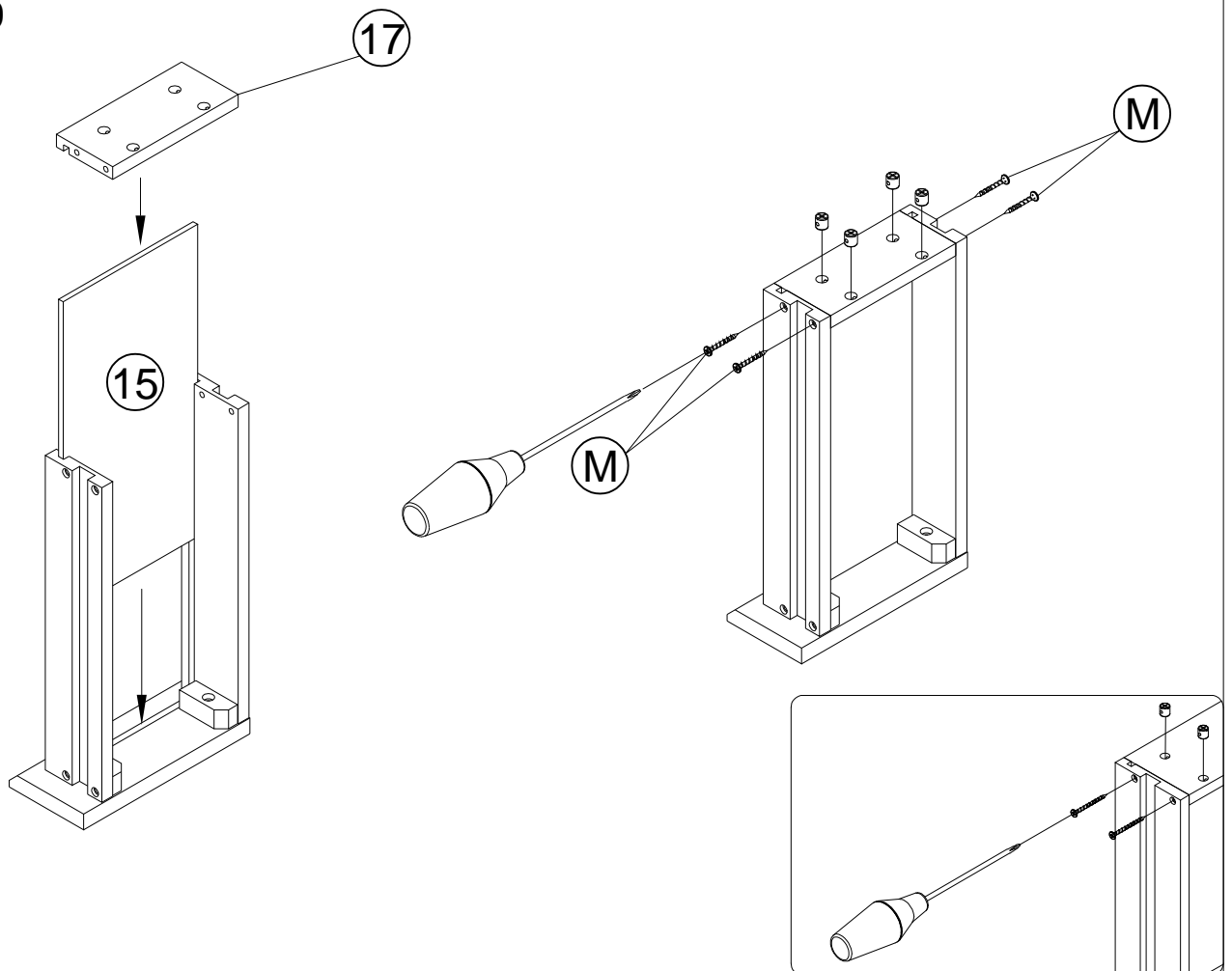

M	M4*50mm 	4PCS
---	---	------

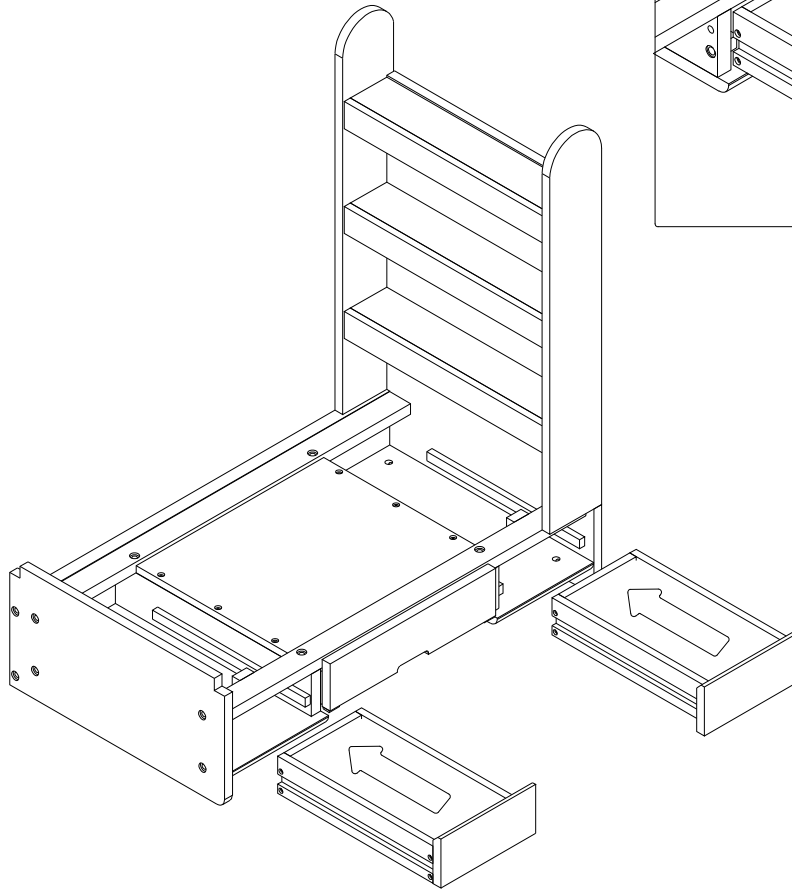

N	Ø 10*10mm 	4PCS
---	---	------

# Step 30

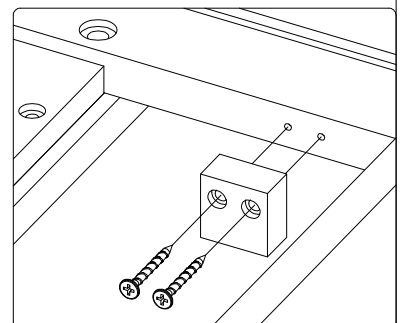
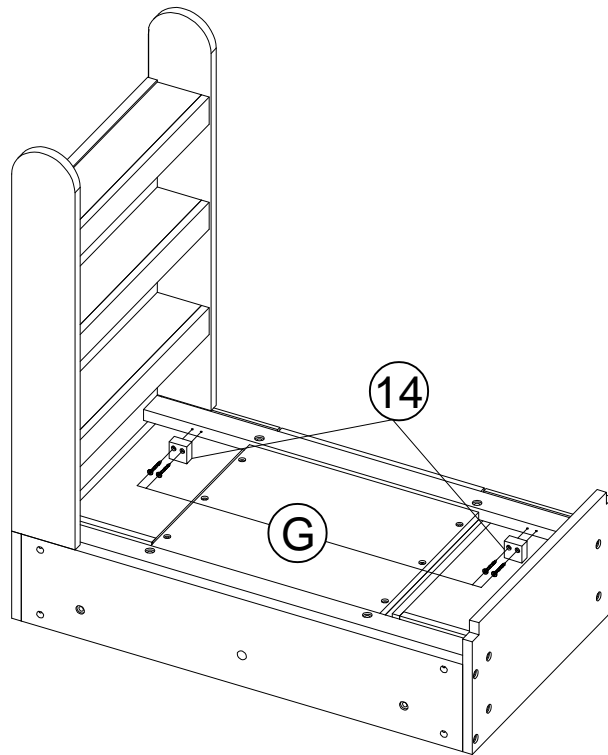

# Step 31



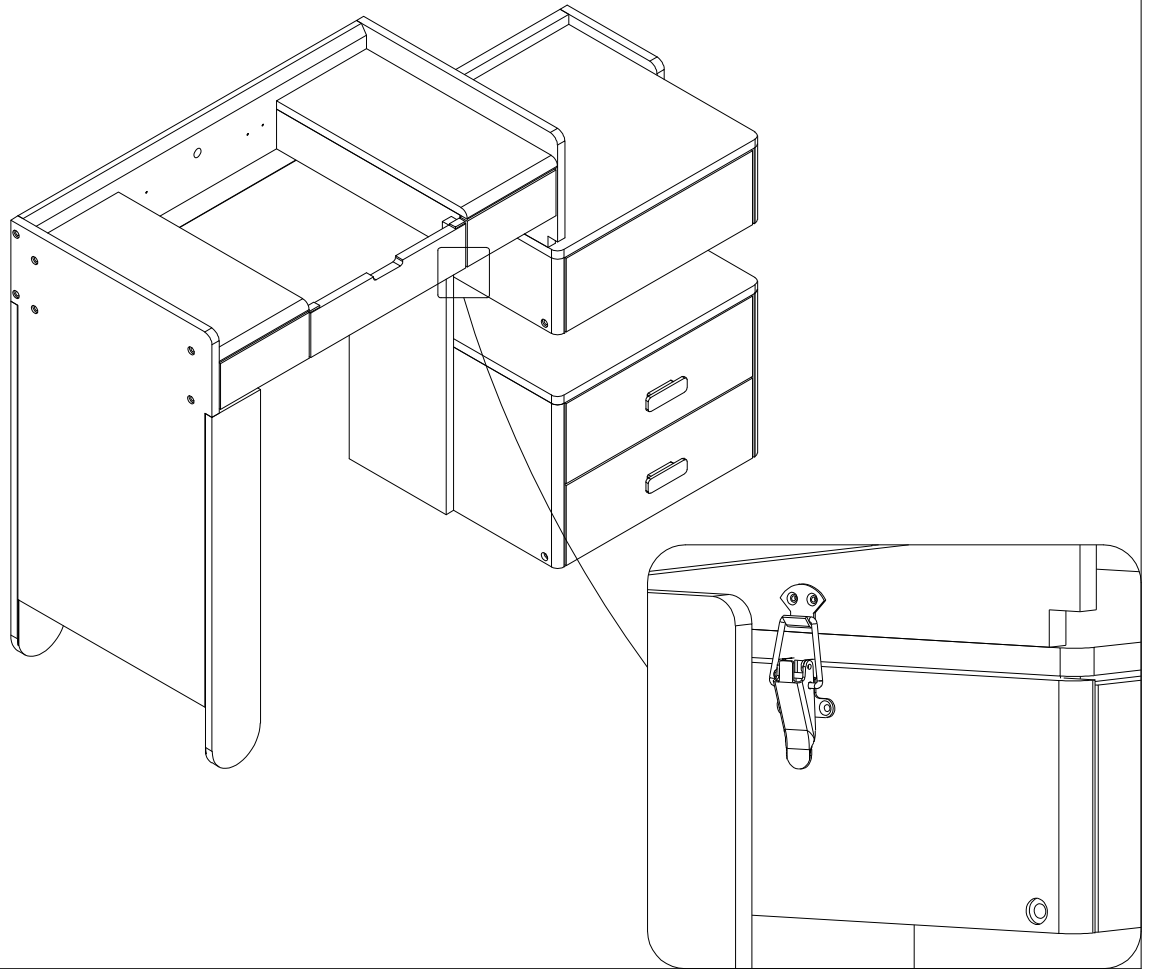

	M4*25mm		4PCS
--	---------	---	------

# Step 32

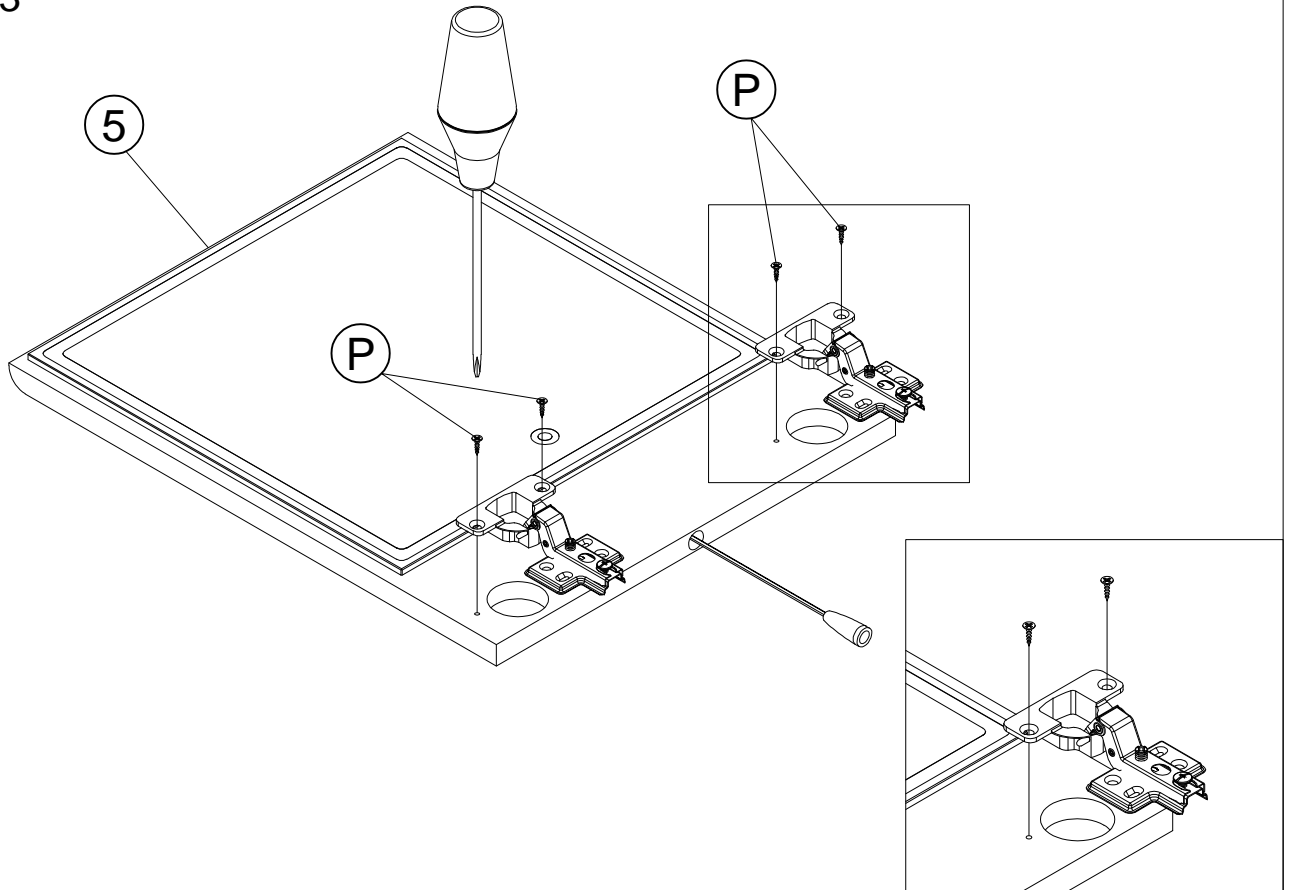

# Step 33

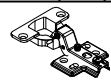

<p>(P)</p>	<p>3.5*15mm</p> 	<p>4PCS</p>	<p>(Q)</p>	<p>Ø 35mm</p> 	<p>2PCS</p>
------------	---	-------------	------------	---	-------------

### Step 34

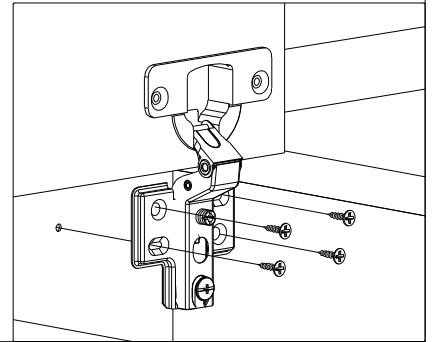
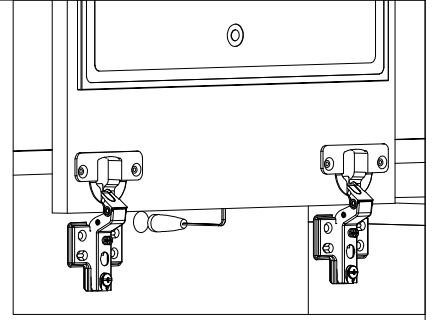
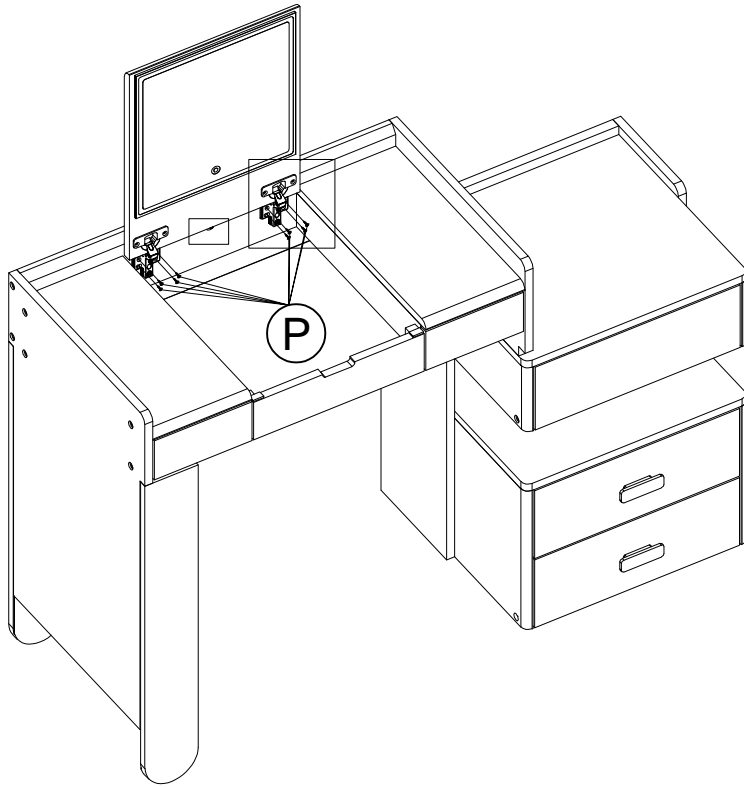

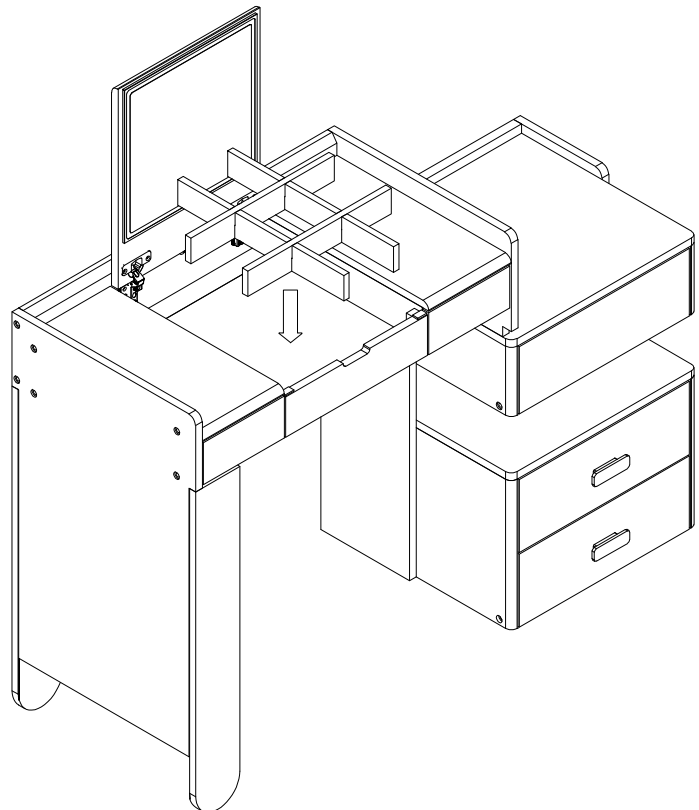
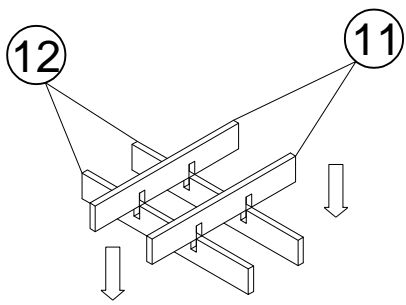

P	3.5*15mm		8PCS
---	----------	---	------

### Step 35

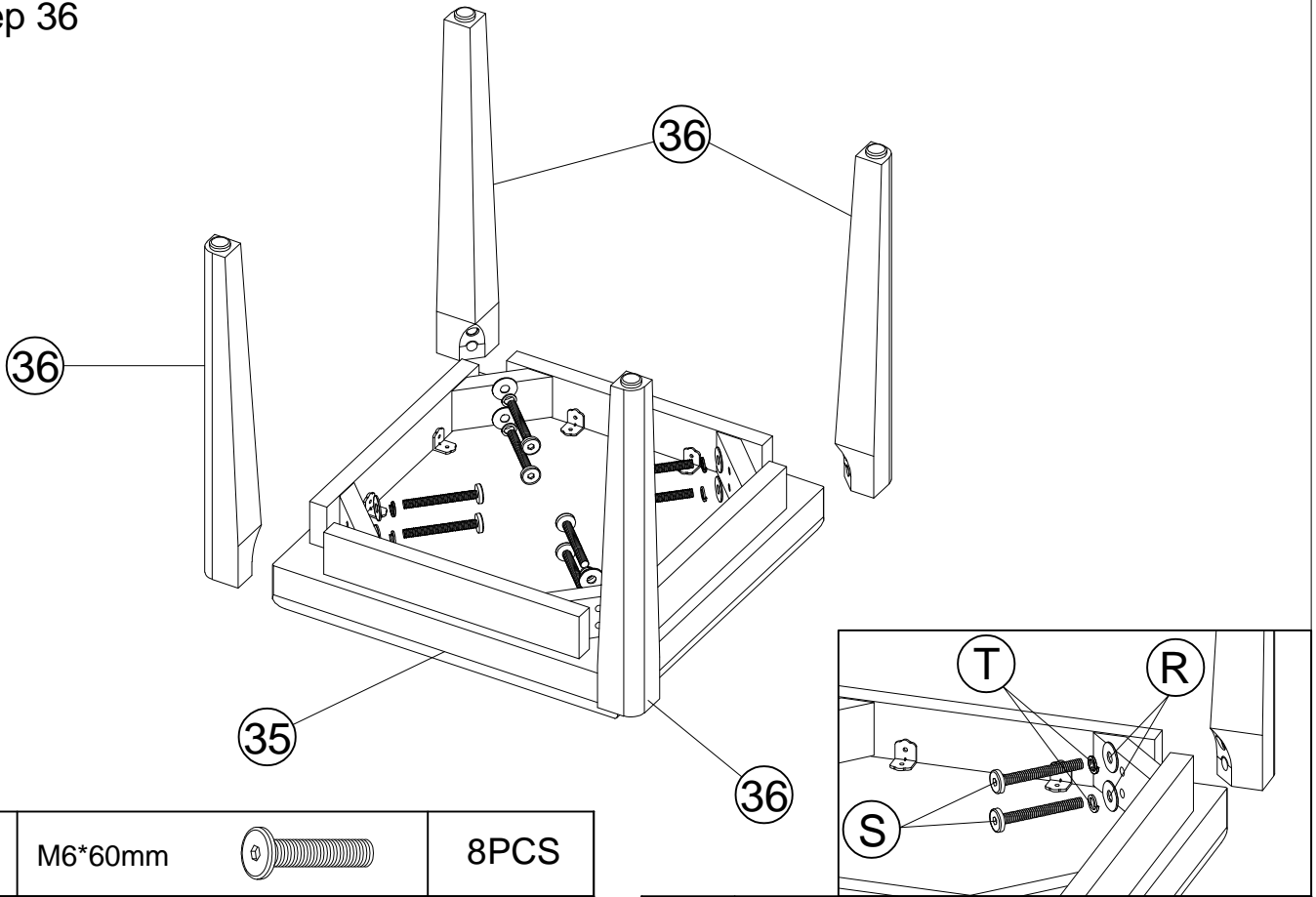

### Step 36

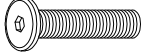

(S)	M6*60mm		8PCS
(R)	Ø1*19mm		8PCS

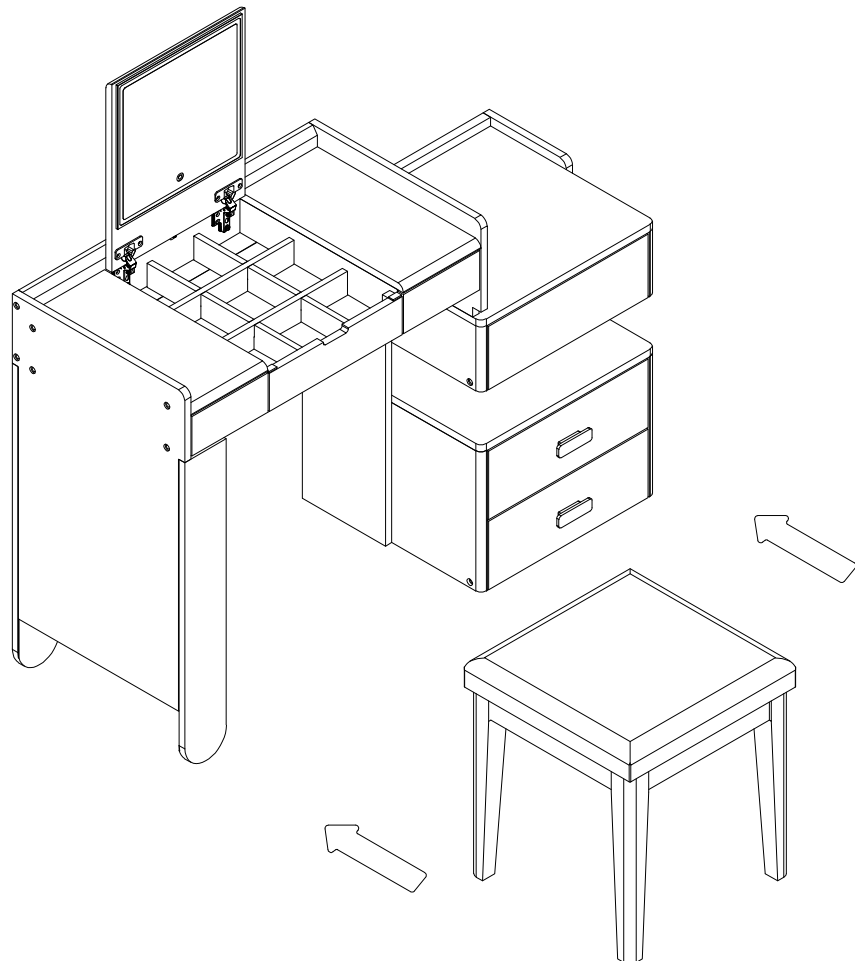

(T)	Ø11*1mm		8PCS
-----	---------	---	------

### Step 37

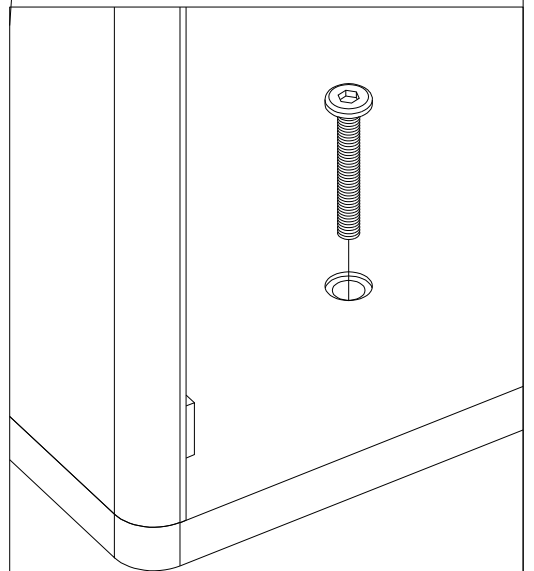
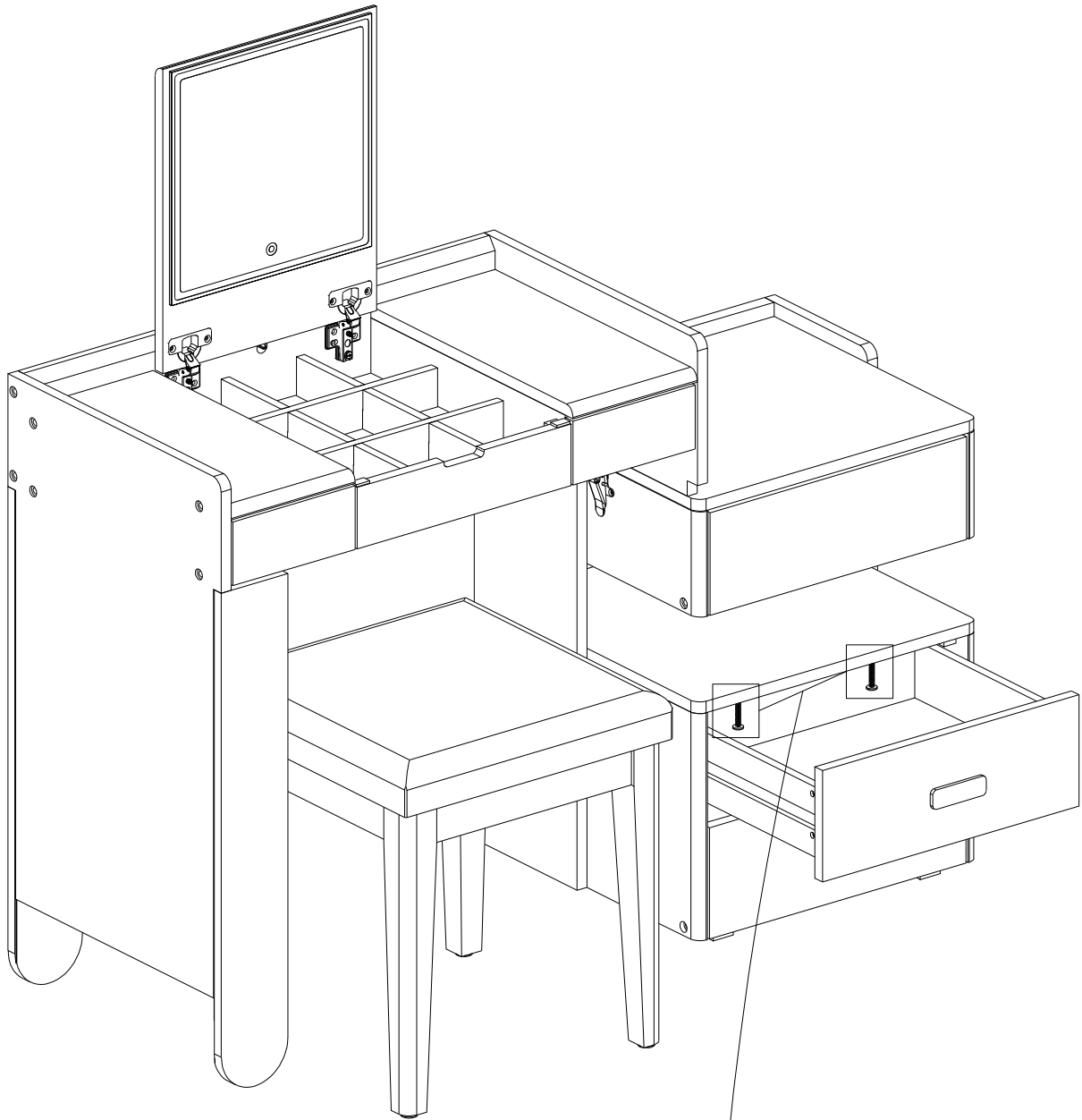

# Step 38







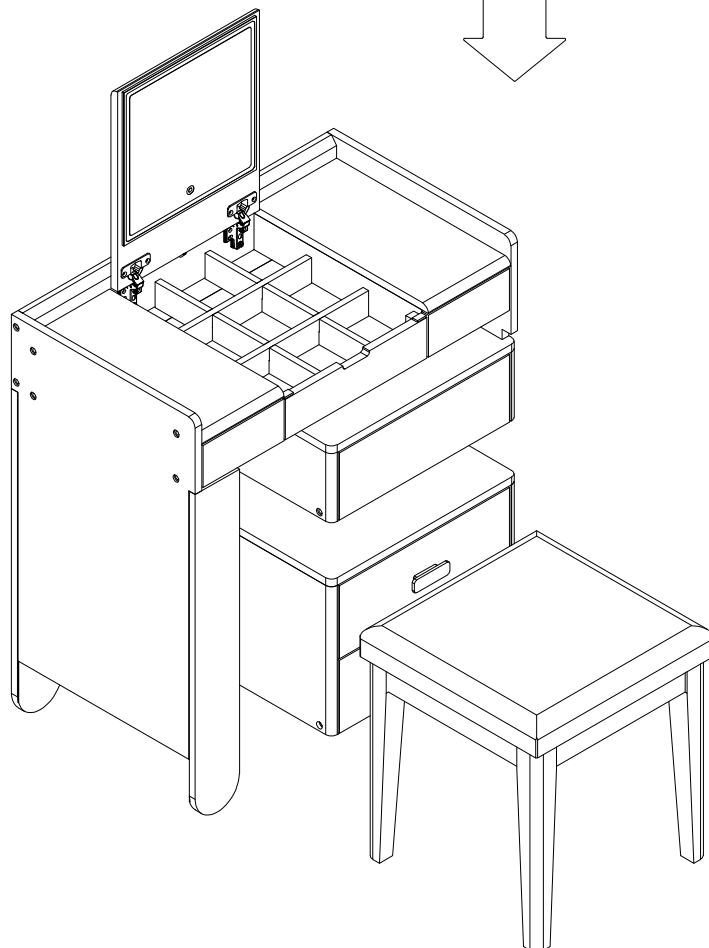
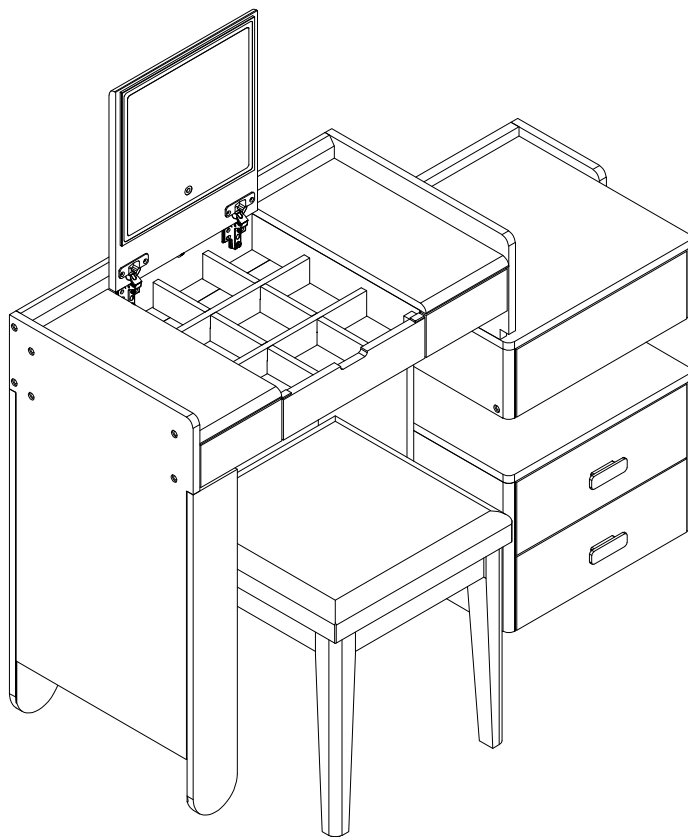

	M6X50mm 	<b>2PCS</b>
--	---	-------------

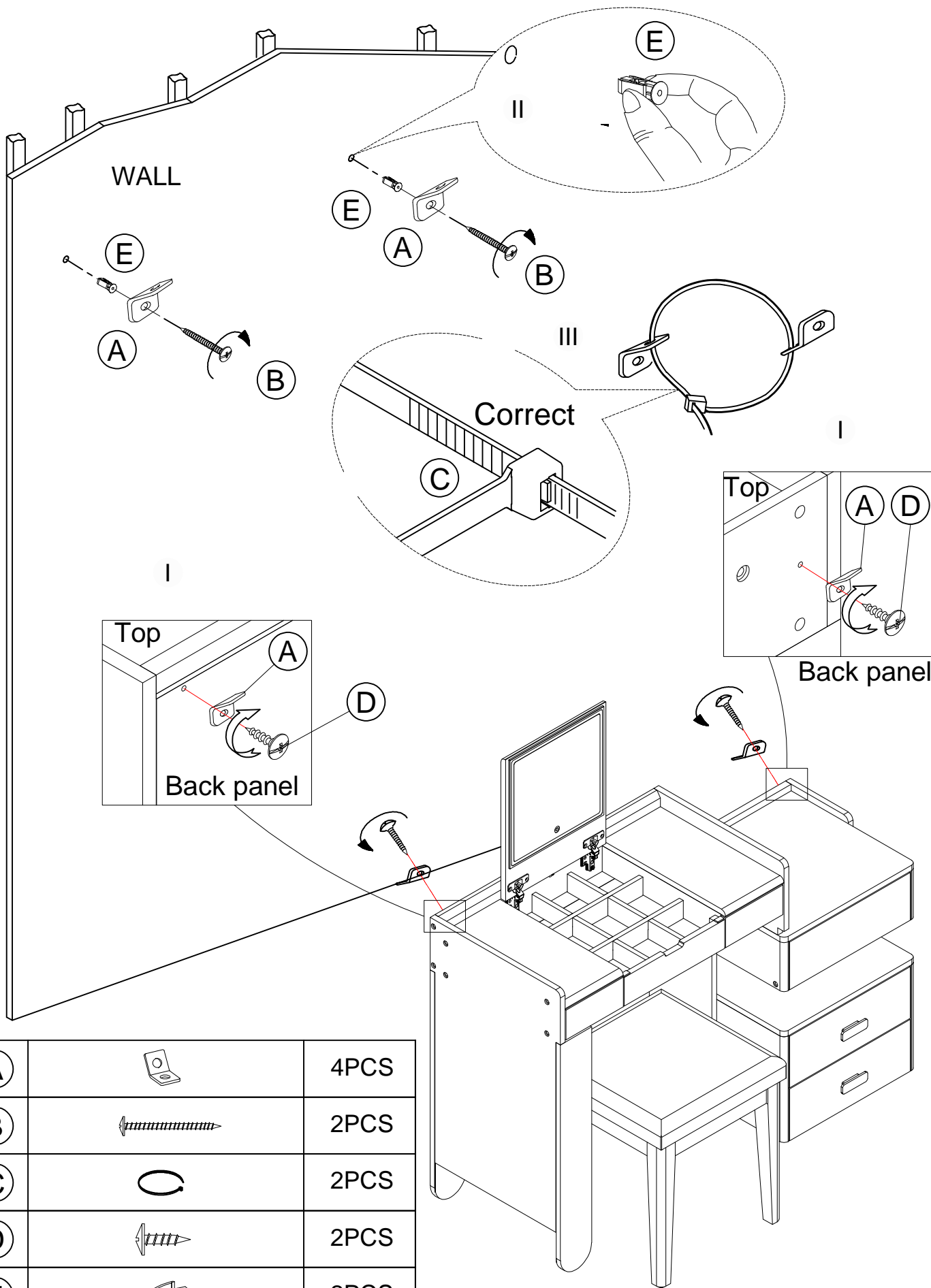
# Step 39



# Step 40



(A)		4PCS
(B)		2PCS
(C)		2PCS
(D)		2PCS
(E)		2PCS