

Assembly Instructions



Assembly Instructions

INSTALLATION GUIDE

ONE PERSON ASSEMBLY: 15 MINUTES (APPROXIMATE)

TOOLS REQUIRED: ALLEN WRENCH (PROVIDED)

BEFORE ASSEMBLY

1. Remove all packaging materials, staples and packing straps from the carton.
2. Confirm with Parts Checklist in Page 3.

ATTENTION

1. Leave sufficient room for assembly.
2. Do not assemble on the ground that may hurt the product.
3. Do not over-tighten any fittings as it may cause damage.
4. **DO NOT USE POWER TOOLS TO ASSEMBLE THIS PRODUCT.**
5. Do not sit or stand on it before the assembly is complete.

DAILY MAINTENANCE

1. Recommended for indoor use only.
2. Wipe with a soft, dry cloth. Keep away from abrasives and household cleaners.
3. Check all the fittings periodically and re-tighten if necessary. Do not use the product if any part is damaged or broken.

Office Desk Chair Warranty Policy

Office desk chairs are warranted from the date of purchase due to material and workmanship factors. Details as follows:

1 YEAR on all unmovable metal parts;

1 YEAR on upholstered PU leather and foam;

1 YEAR on component parts including control mechanism, gas cylinder, wood, plastic parts, base and casters.

To make a warranty claim, purchase proof, problem descriptions as well as pictures that shows the problem clearly.

Problem verified, will:







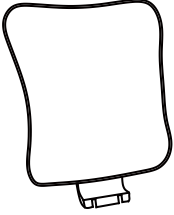

a) Send replacement parts.

b) Send a new product if necessary, customer need to return the original item to our warehouse. Return freight will be undertaken.

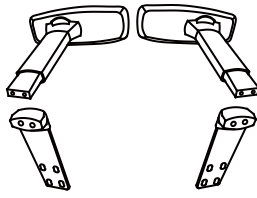
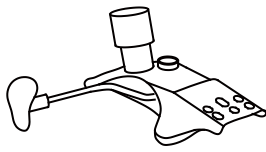
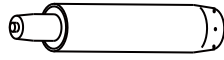
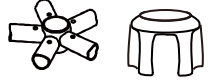
RETURN POLICY

30 Days Free Return Policy after receiving the product is available. Offers prepaid return labels and undertake the return freight.

PARTS CHECK LIST

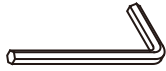
					
Ax1	Bx1	Cx1	Dx1	Ex1	Fx1
					
Ix5	G1x5 (18mm)	G2x8 (20mm)	G3x8 (25mm)	G4x3 (40mm)	Jx1

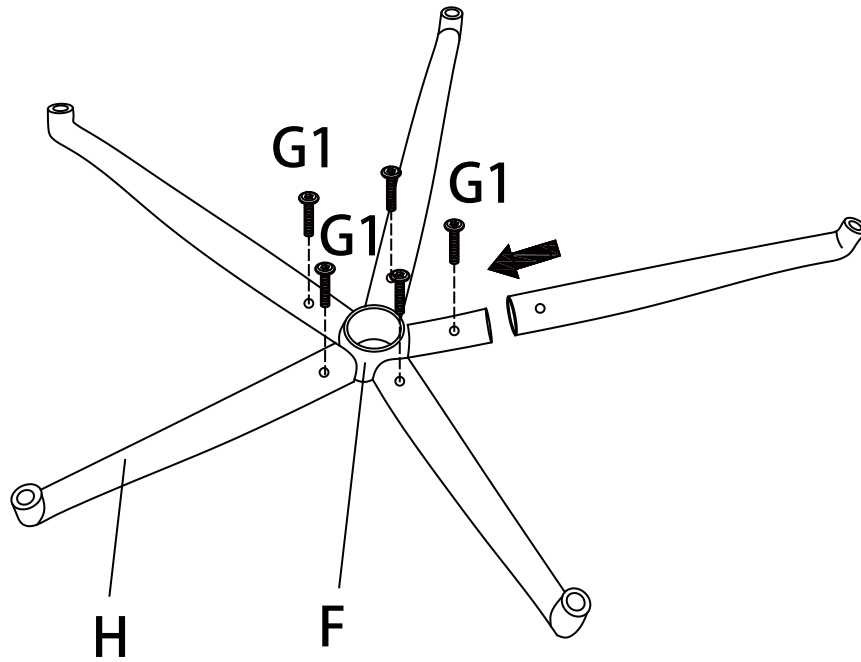

Step 1: Insert part **H** into Part **F** and screwed with **G1x5**.

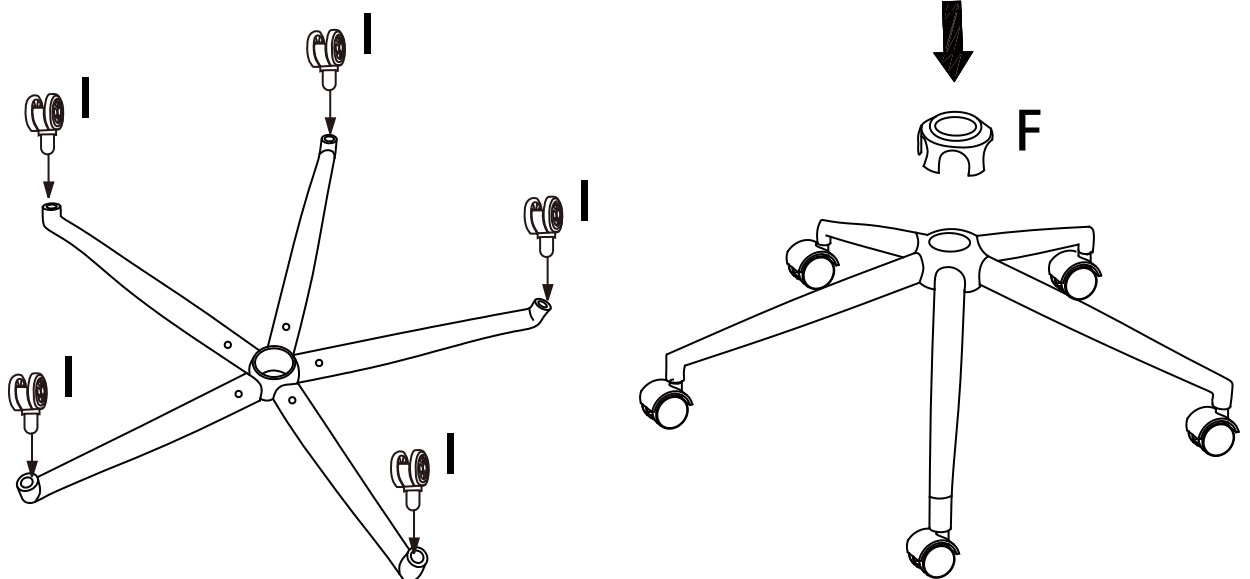
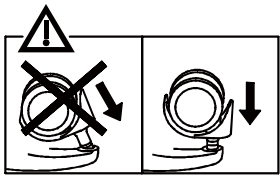

Step 2: Insert Casters **Ix5** into the base with force. Insert the gap **F** into the center of the base.

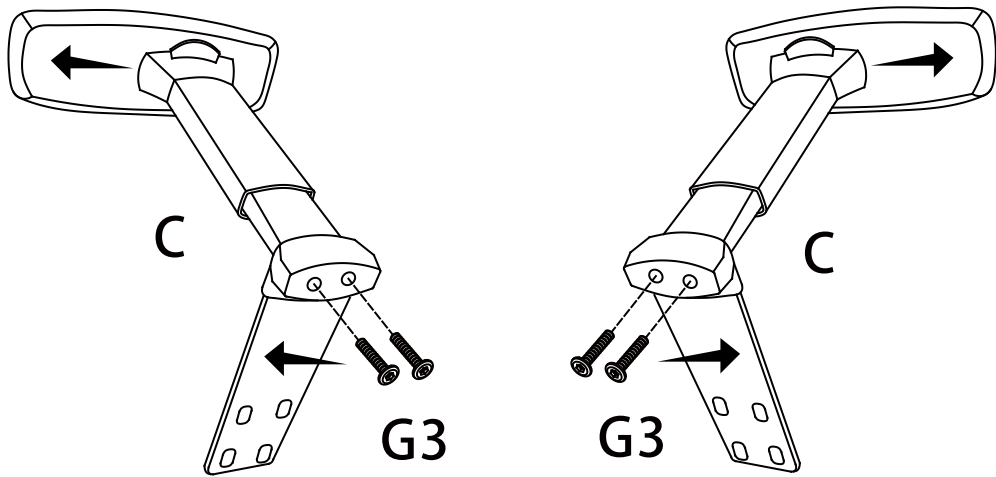

Step 3: Attach the Armrests **Cx2** with Screws **G3x4**.

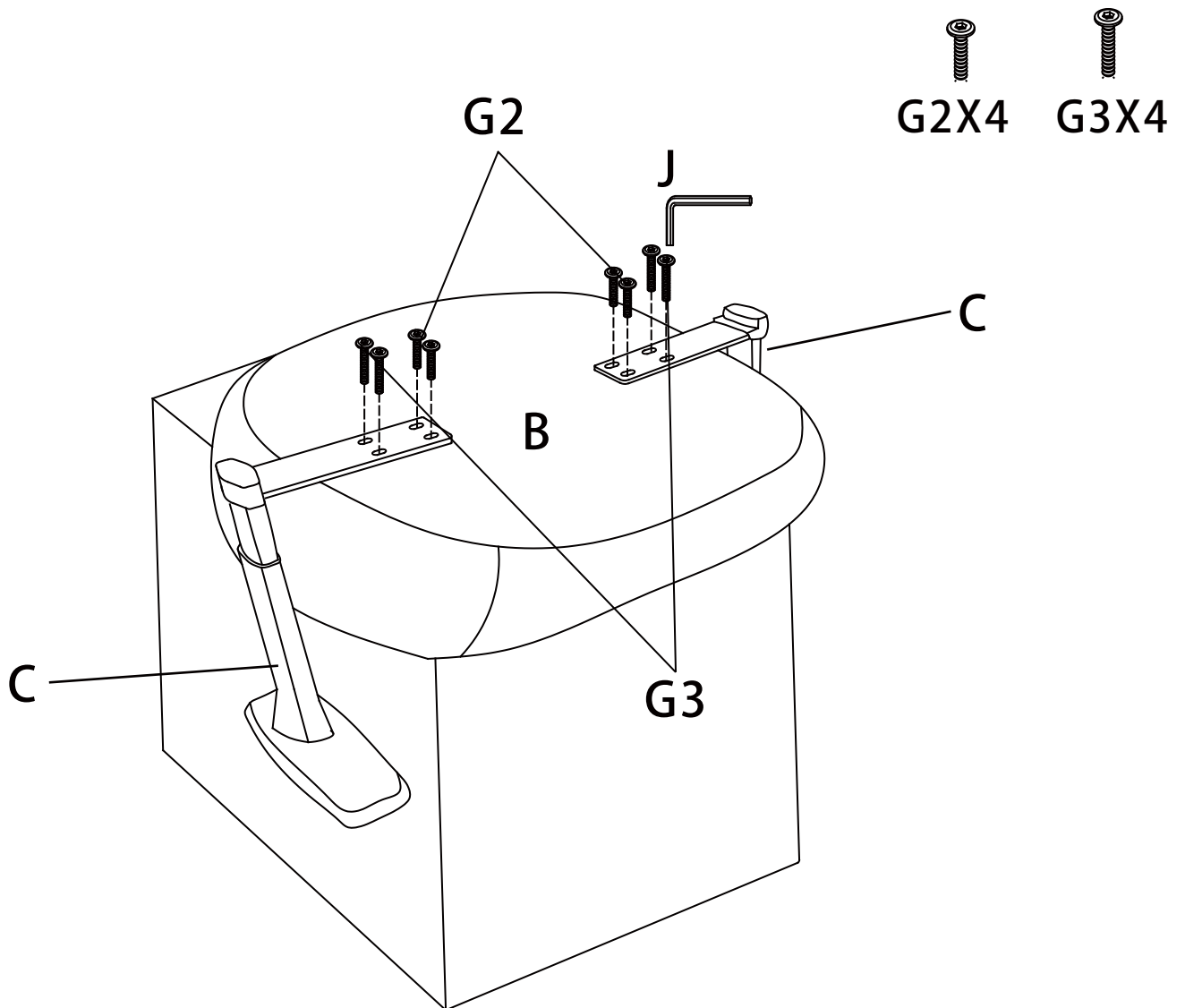

Step 4: Attach the Armrests **Cx2** to the Seat **B** with Screws **G2x4** and **G3x4** as the picture.

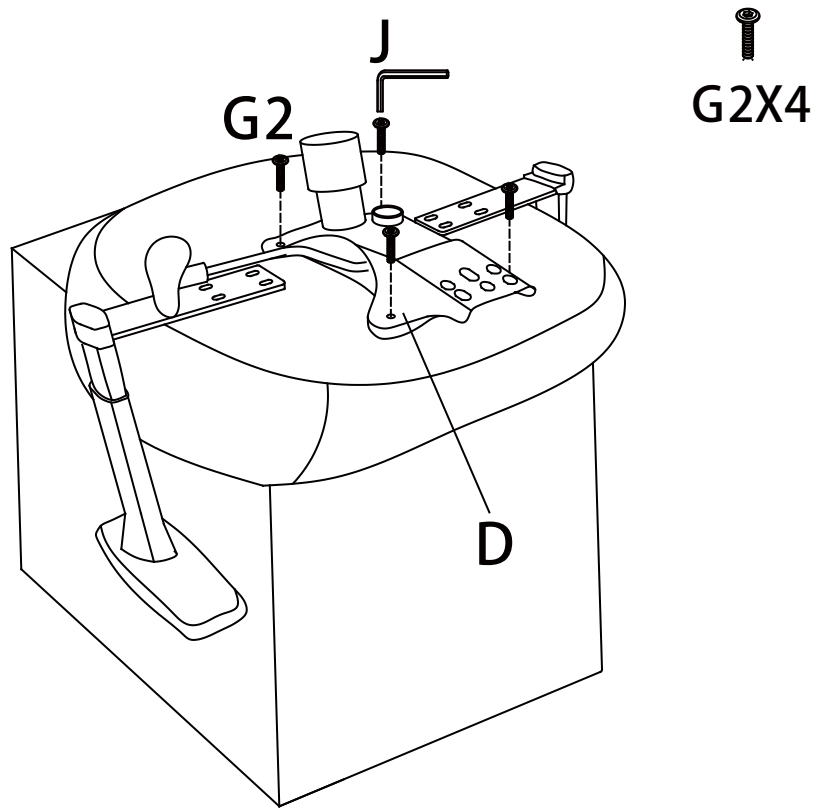

Step 5: Attach the tilt mechanism **D** to the Seat **B** with Screws **G2x4**.
Please note the orientation of the front of the seat and the mechanism.

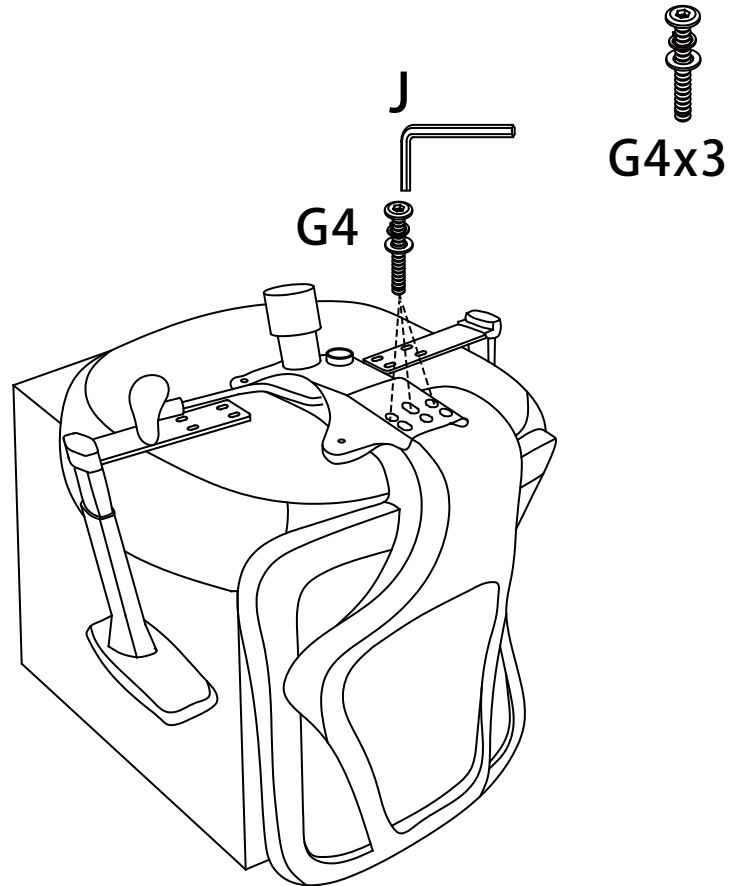

Step 6: Attach the Back **A** to the Seat **B** with Screws **G4x3**.

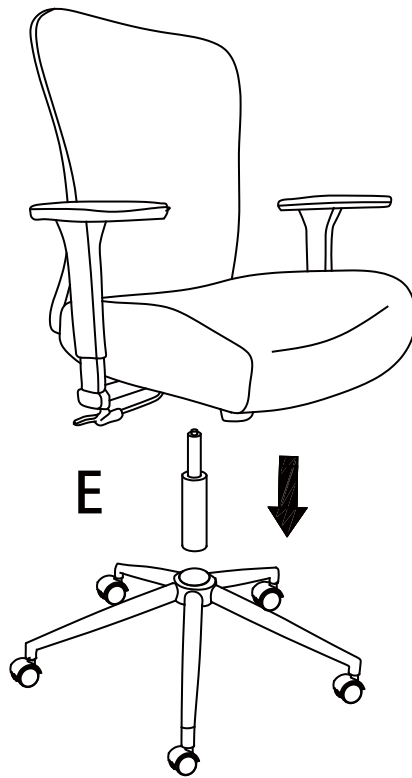

Step 7: Insert the gas lift **E** into the center of the base
Remove the small black gas lift cover before assembling the rest of your chair.
Attach the assembled seat to the assembled base by aligning the hole in the tilt mechanism to the top of the gas lift. Push down firmly to secure.



Step 8: Enjoy your new chair.