

# Assembly Instructions

830571 CHAISIDE TABLE - CINNAMON

830578 CHAISIDE TABLE - ESPRESSO

**Product Issues? Please Call Us Before Contacting Your Retailer At 1-800-549-3300.**

**Email [customerservice@mshome.co](mailto:customerservice@mshome.co), visit [www.mshome.co](http://www.mshome.co)**

**We can help with Assembly Issues, Part Requests, Damages, & All Other Product Related Questions**

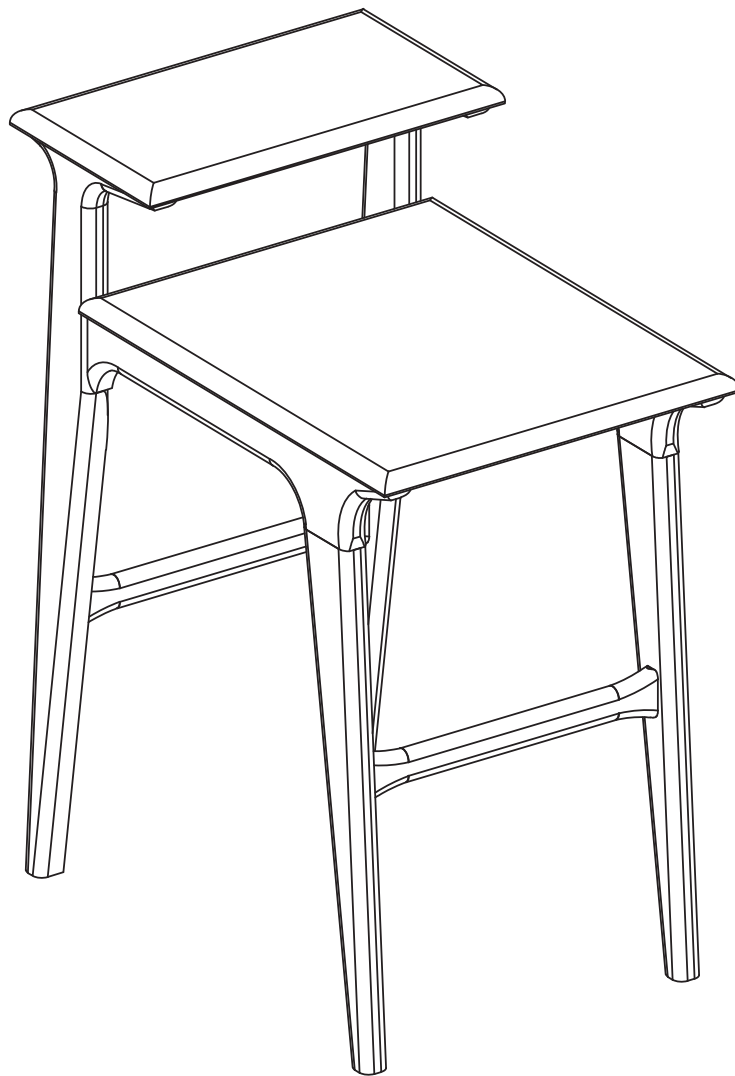

MSH - USA

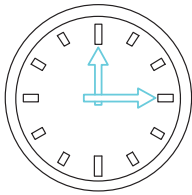

15 min

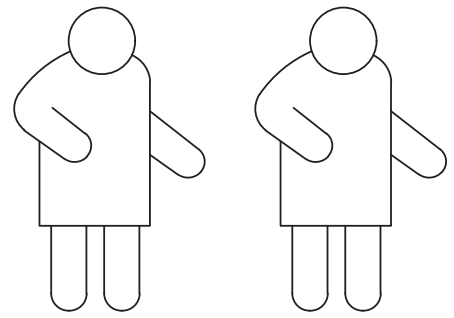

Two People Required  
for Assembly

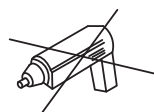
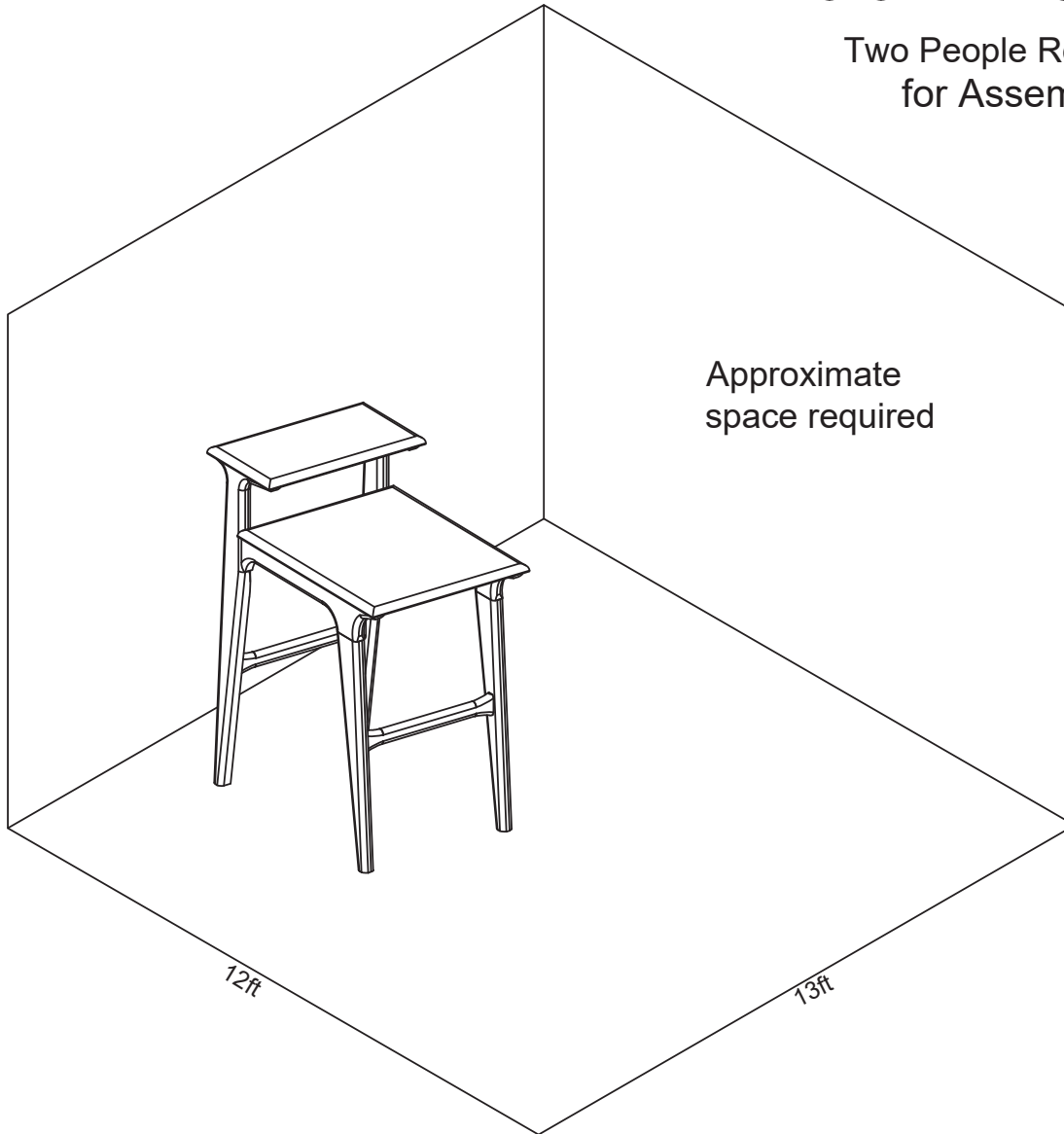

Do Not Use Power Tools

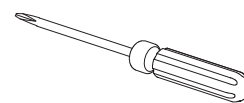



Phillips Head (Not Provided)

## PARTS INCLUDED

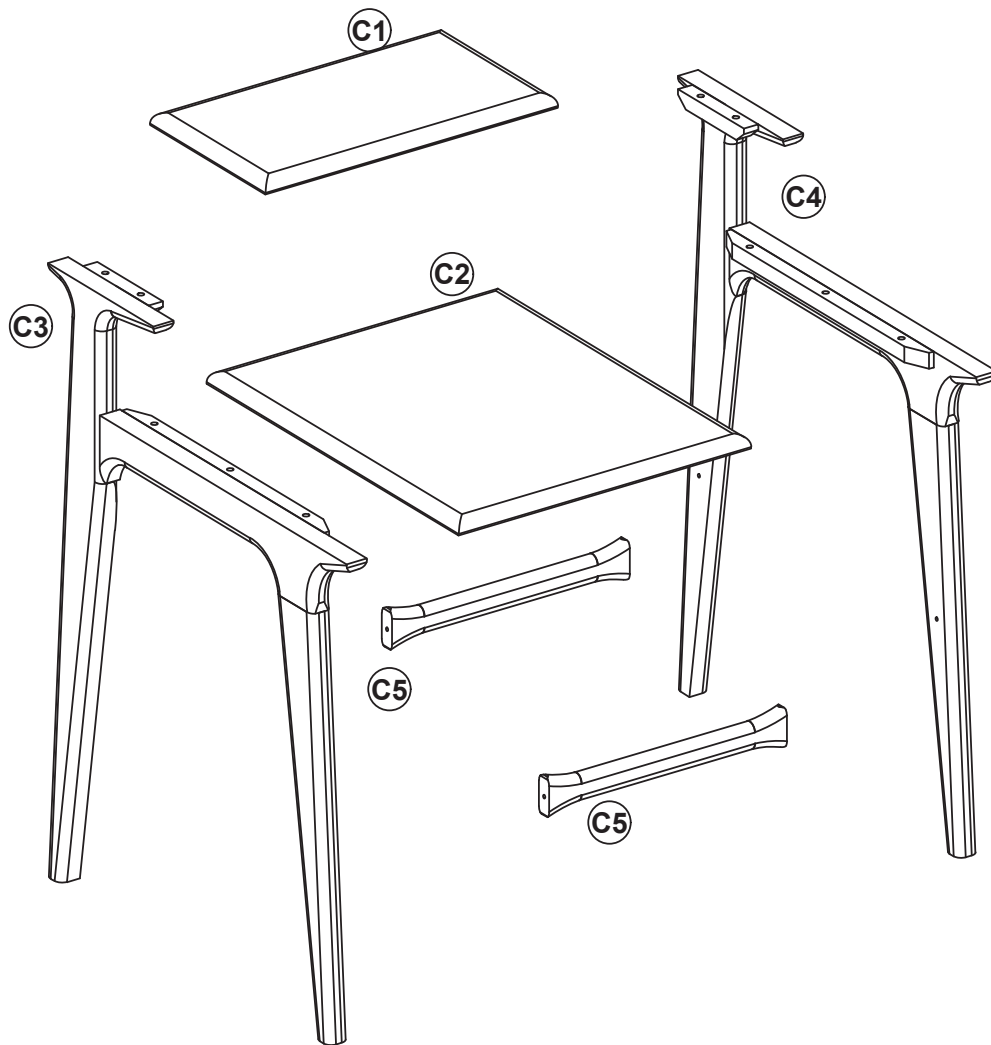
- (C1) Top Panel x1
- (C2) Bottom Panel x1
- (C3) Right Leg Frame x1
- (C4) Left Leg Frame x1
- (C5) Stretcher x2

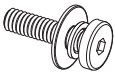

Hardware Pack

<p>A</p>  <p>Ø6x25 (mm) : 10pcs</p>	<p>B</p>  <p>Ø4x45 (mm) : 4pcs</p>	<p>C</p>  <p>1pc</p>
--	---	---

1

A x 4

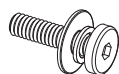

C x 1



Please lay all components on smooth flat surface to prevent scratches

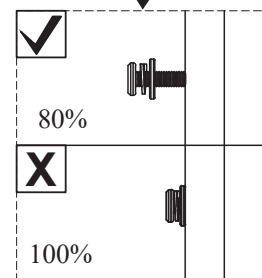
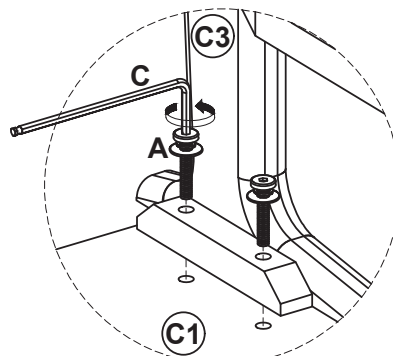
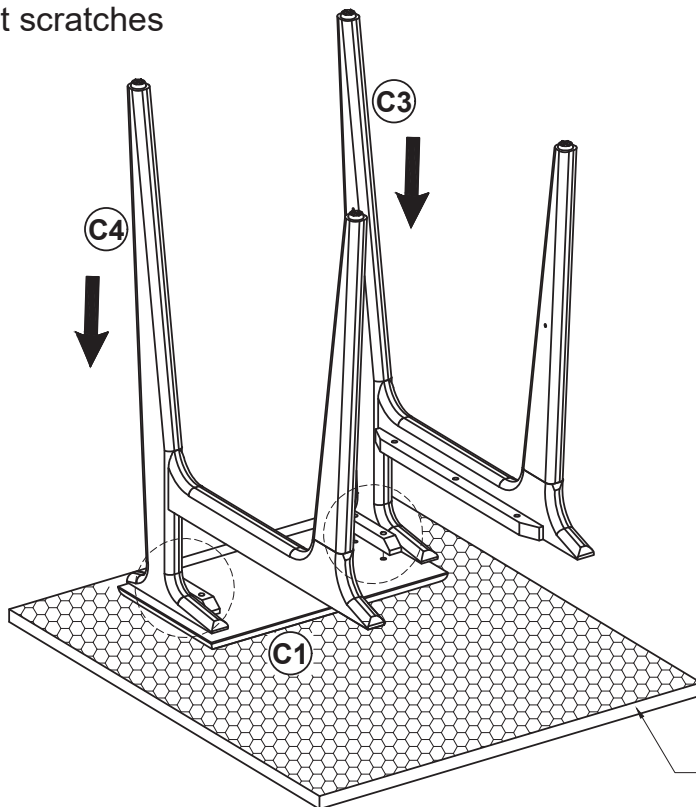

2

A x 6

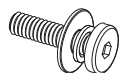

C x 1

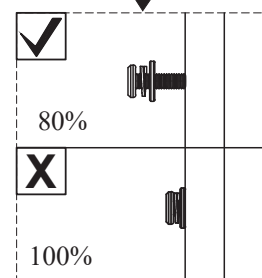
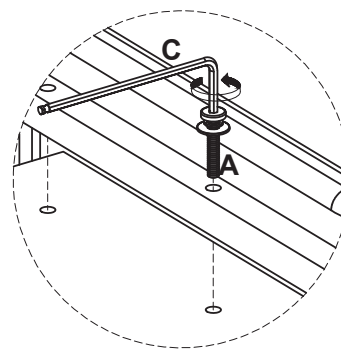
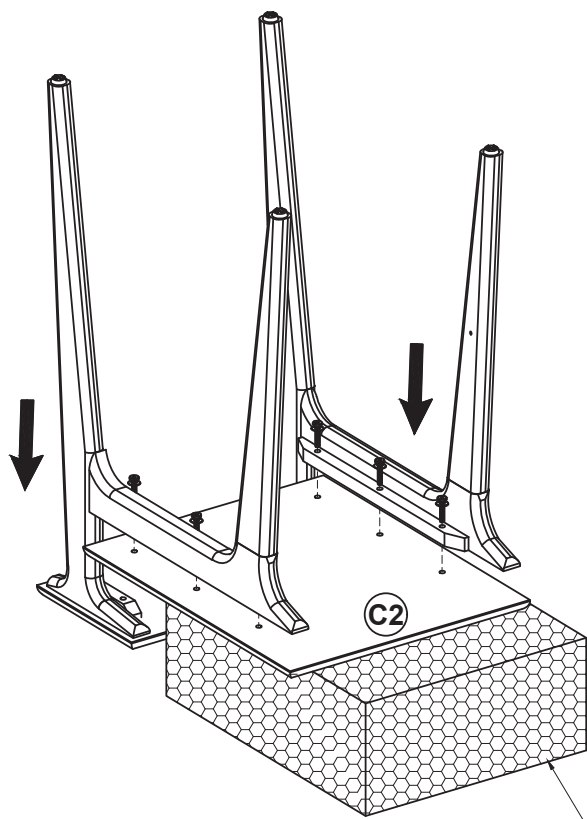

3

B x 4

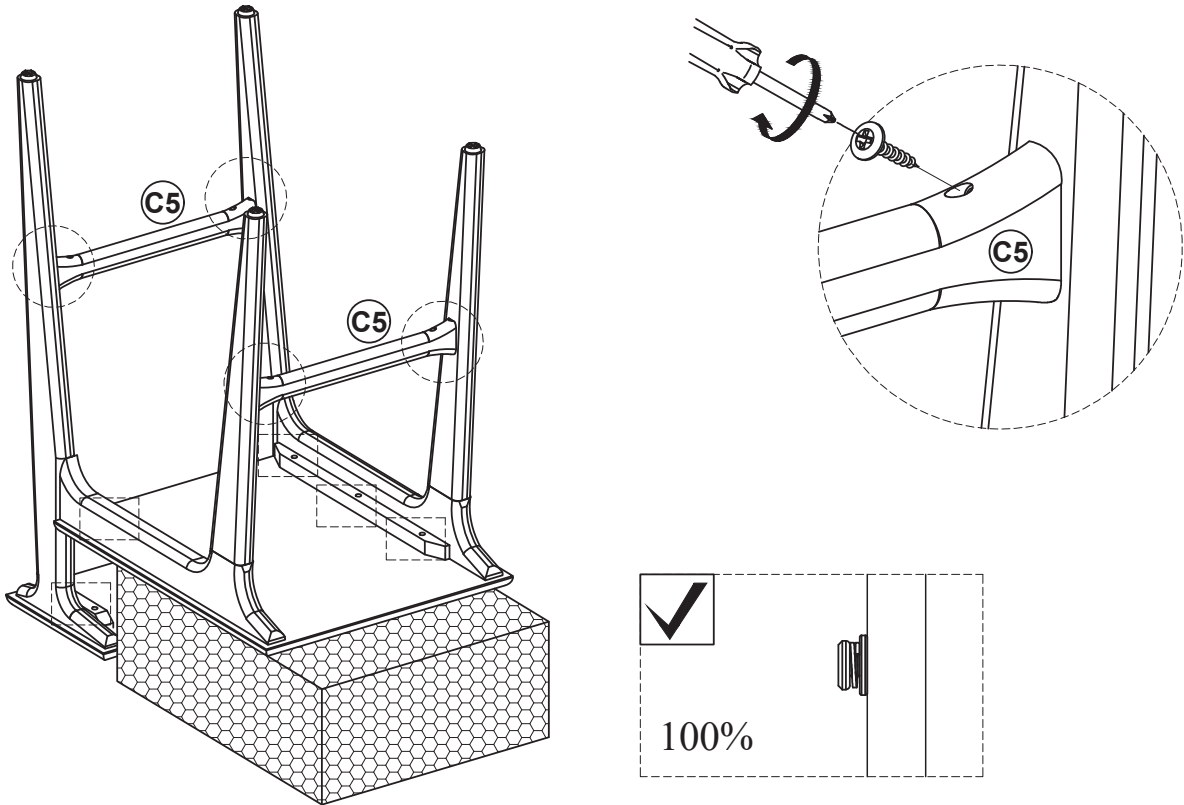
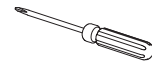

4

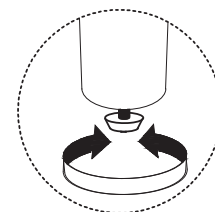
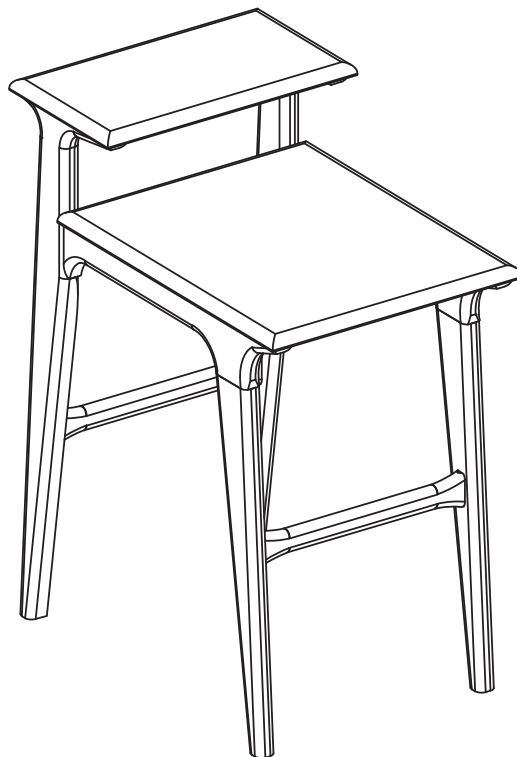

Adjustable floor leveler



## Replacement Part Form

Have an issue? Need a replacement part?

Please E-mail us before contacting your retailer, we will be happy to fix your issue.

This process will be hassle free! We will replace your part for free!

Please follow these easy steps below.

You will need to E-mail *Martin Svensson Home* Customer Service: [Customerservice@mshome.co](mailto:Customerservice@mshome.co)  
(Please note it is .CO not .com)

Please scan or take a picture of this form filled out.

1. **Customer Name:** \_\_\_\_\_

2. **SKU# with issue:** \_\_\_\_\_

3. **Replacement Part # needed** \_\_\_\_\_

\*Please reference the Assembly Instructions to identify needed part #'s

4. **Photos of the Damaged Part** (please include in the e-mail)

5. **Brief description of the part issue:** \_\_\_\_\_

6. **Proof of Purchase** (please provide a copy of your purchase receipt)

7. **Ship to Address:** \_\_\_\_\_

\_\_\_\_\_  
\_\_\_\_\_

8. **Other contact information:**

**Email Address** \_\_\_\_\_

**Phone #** \_\_\_\_\_

\*If possible, could you please provide the UPS or FedEx tracking from original shipment \_\_\_\_\_

\*If possible, could you please provide the P.O. # - information found on back/underneath product \_\_\_\_\_

\*If you have any other question, we are happy to assist with assembly questions or all other parts related questions. Thank you for your purchase!