

ASSEMBLY INSTRUCTIONS

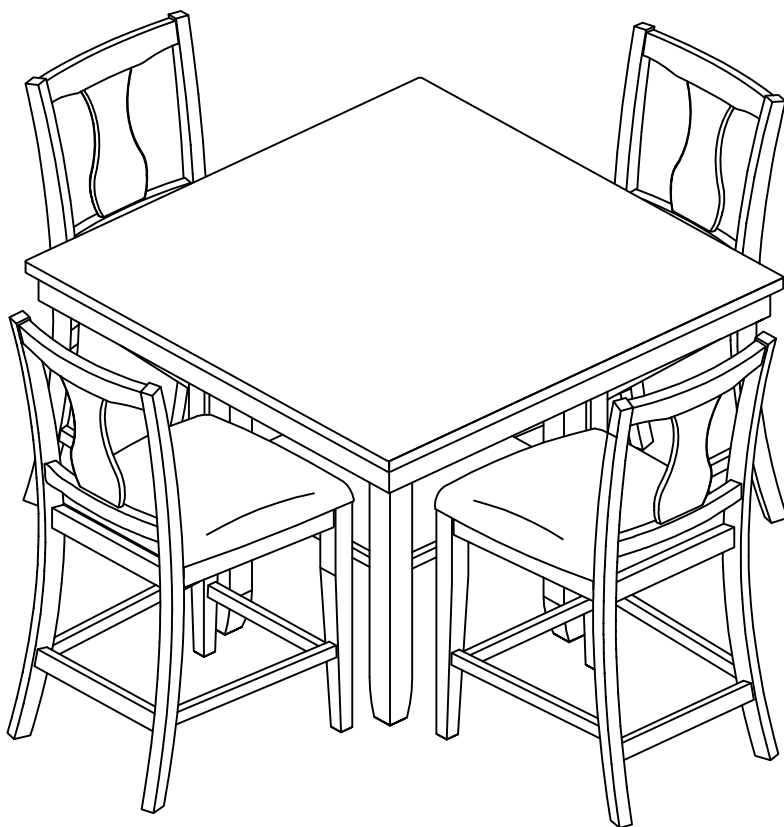

TOOLS REQUIRED



Allen Wrench

(Included)



Phillips
Screwdriver

(Not Included)



**2 - People
Recommended**

ASSEMBLY RATING



EASY —————> DIFFICULT

The Assembly Rating is a 5-point system showing the level of effort needed to assemble a specific product.

PRE ASSEMBLY INTRODUCTION

We understand building ready-to-assemble furniture can be a challenging experience for some. To help avoid confusion, we have provided some helpful tips that may speed up the process.

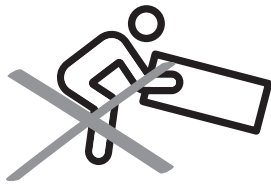

Teamwork

ALWAYS have at least two people to help with transporting and assembling the product to avoid potential injury and/or damage.

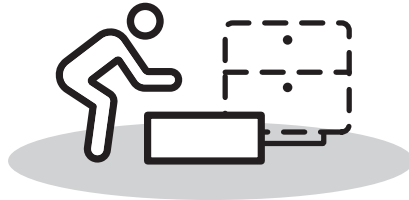
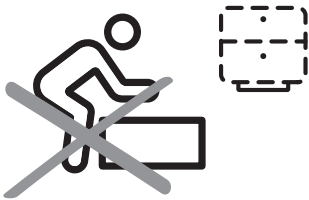

Suitable Location

Assembling near the area of the intended location is highly recommended.



Sufficient Space

Make sure you have enough space to move around during the assembly.



Avoid Scratches

Use cardboard, blankets or a carpeted area while assembling furniture to prevent scratches.

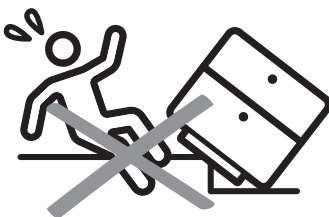

Flat Surface

Make sure the furniture rests on a flat and level surface with each leg evenly touching the floor.

ASSEMBLY AND CARE ADVICE



FAILURE TO FOLLOW THE GUIDELINES BELOW MAY RESULT IN INJURY AND/OR PROPERTY DAMAGE.



Position each part correctly and insert screws or bolts into their respective holes.



Use the appropriate hand tools or power tools for assembly. Select steps, such as tightening screws and/or bolts, may require hand tools to avoid causing damage during assembly.

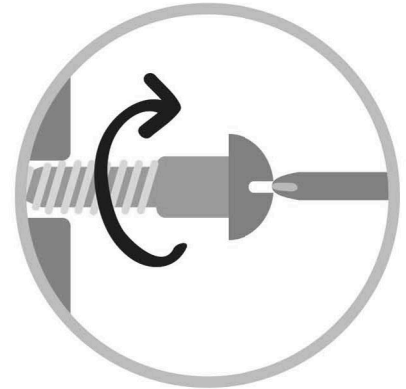

Turn clockwise to tighten and only tighten when step is completed or when instructed to do so.



Save the instructions and store any supplied tools for later maintenance.



After two weeks, check and tighten any loose hardware and repeat again every six months thereafter.

IT IS THE USER'S RESPONSIBILITY TO MAINTAIN THE FURNITURE. THE HARDWARE MAY LOOSEN OVER TIME AND MAY CAUSE THE FURNITURE TO BE WOBBLY AND UNABLE TO SUPPORT ITS INTENDED WEIGHT CAPACITY. THIS MAY LEAD TO COLLAPSE AND MAY CAUSE SERIOUS INJURY.

5PC. COUNTER HT. TABLE SET-TABLE

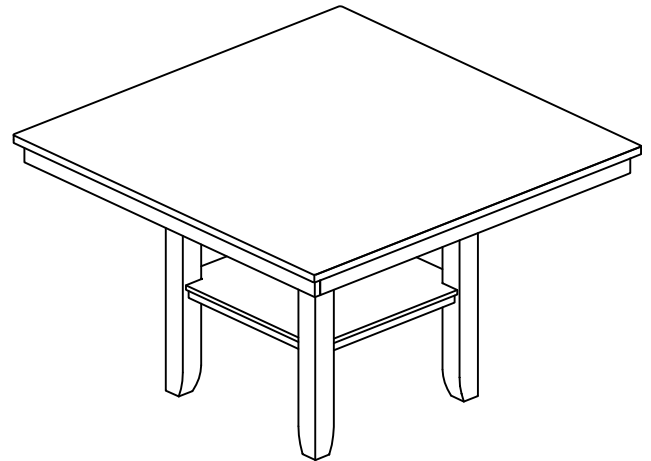
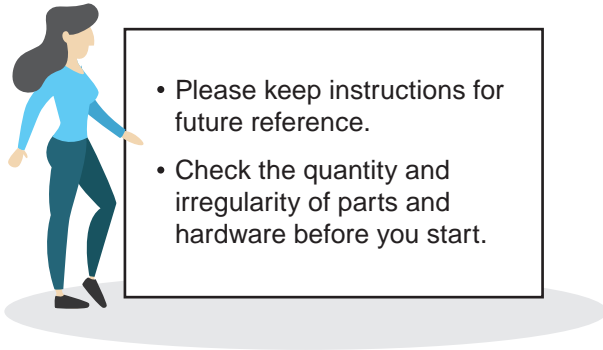

PARTS

#1 1pc

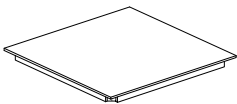

Table Top

#2 4pcs

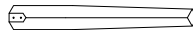

Table leg

#3 1pc

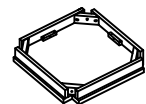

Table Shelf

HARDWARE

#A 12pcs



Bolt $\phi 5/16$ "X2-1/2"

#B 12pcs



Spring Washer $\phi 5/16$ "

#C 12pcs

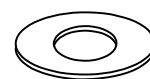

Flat Washer $\phi 5/16$ "

#D 1pc



Wrench 12mm

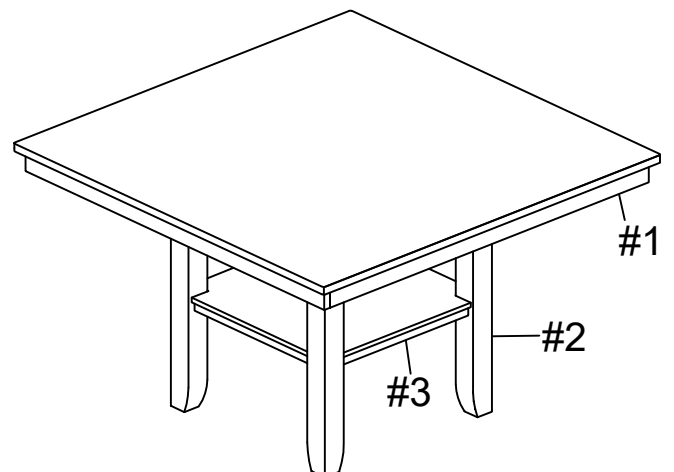

ASSEMBLY INSTRUCTIONS

1

1) Prepare 8 bolts assembly by Spring Washer (#B), then flat washer (#C) onto bolts (#A). Align legs (#2) to the holes of the table top (#1). Secure by using bolts (#A), but do not fully tighten.

- Part #1 X 1pc
- Part #2 X 4pcs
- Hardware #A X 8pcs
- Hardware #B X 8pcs
- Hardware #C X 8pcs

2) Adjust leveler according to ground level

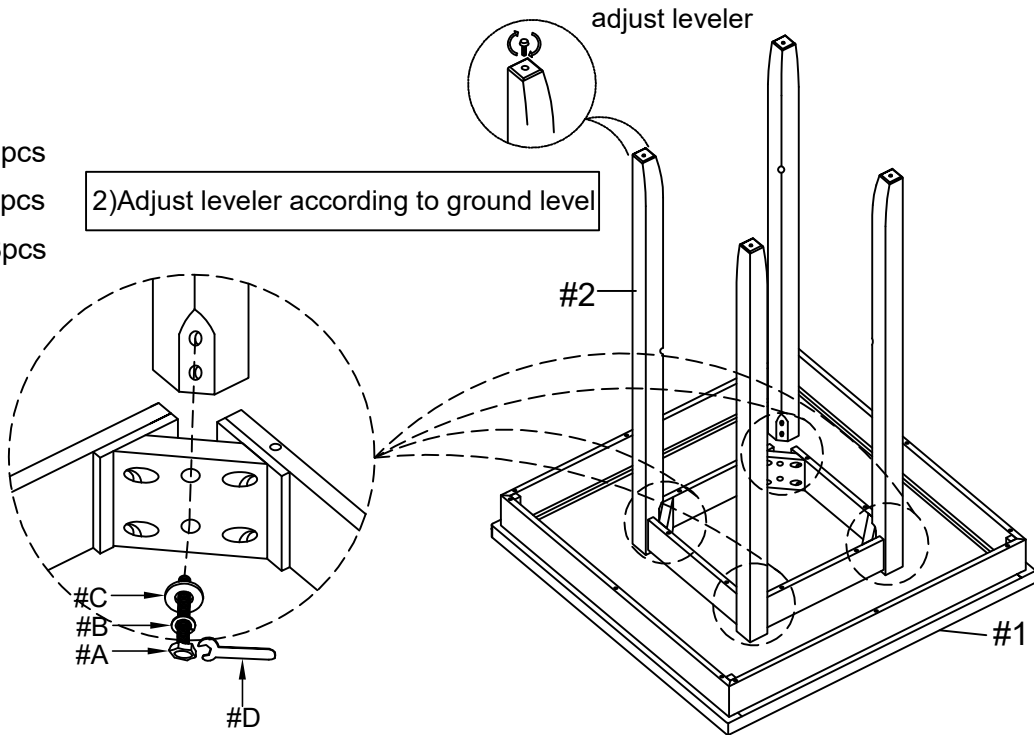

2

- Hardware #A X 4pcs
- Hardware #B X 4pcs
- Hardware #C X 4pcs

1) Prepare 4 bolts assembly by Spring Washer (#B), then flat washer (#C) onto bolts (#A). Secure shelf (#3) by using bolts (#A). Fully tighten all bolts.

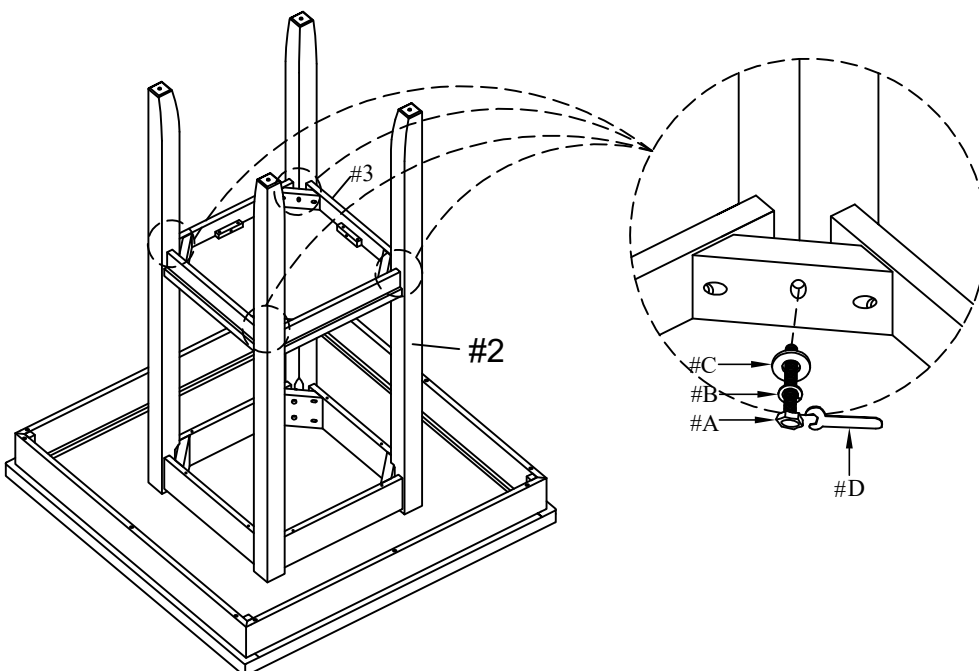

ASSEMBLY COMPLETED



Please ensure the furniture rests on even and flat surface. If the product wobbles or feels loose, double-check all bolts and/or screws are properly tightened and secured.



Keep this handy!

Please retain this instruction manual and any order-related information for future reference.



Lift, don't drag!

To avoid damage to product please always LIFT the product when transporting at adjusting the placement.

5PC. COUNTER HT. TABLE SET-CHAIR

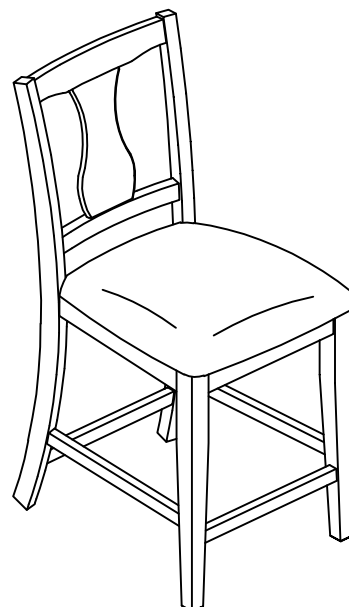

• Please keep instructions for future reference.
 • Check the quantity and irregularity of parts and hardware before you start.

PARTS

#1 1pc x4



Chair back

#2 1pc x4

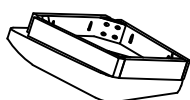

Seat

#3 2pcs x4

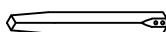

Front leg

#4 2pcs x4



Side stretcher L/R

#5 1pc x4



Front stretcher

HARDWARE

#A 4pcs X4



Bolt $\phi 1/4$ "X3"

#B 4pcs X4

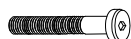

Bolt $\phi 1/4$ "X2-1/2"

#C 2pcs X4



Bolt $\phi 1/4$ "X1-1/2"

#D 10pcs x 4



Spring Washer $\phi 1/4$ "

#E 10pcs x 4



Flat Washer $\phi 1/4$ "

#F 1pc x4



Allen Wrench M4

#G 6pcs x6

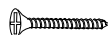

screws $\phi 8$ X1-3/4"

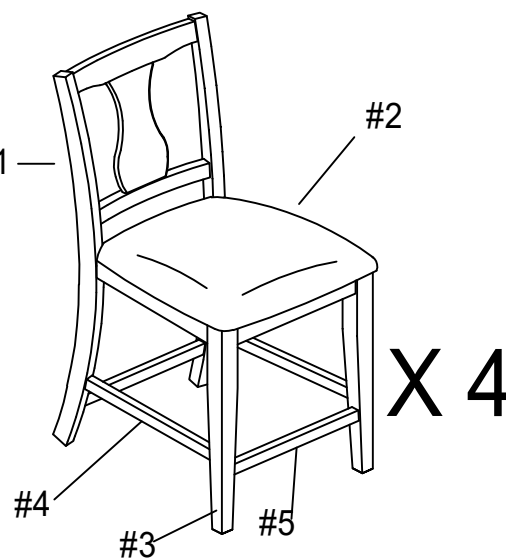

ASSEMBLY INSTRUCTIONS

1

Prepare 2 bolts assembly by Spring Washer (#D), then flat washer (#E) onto bolts (#C). Align seat frame (#3) to the chair back (#1), then secure by using bolts (#C). Do not fully tighten bolts (#C).

Part #1 X 1pc

Part #3 X 1pc

Hardware #C X 2pcs

Hardware #D X 2pcs

Hardware #E X 2pcs

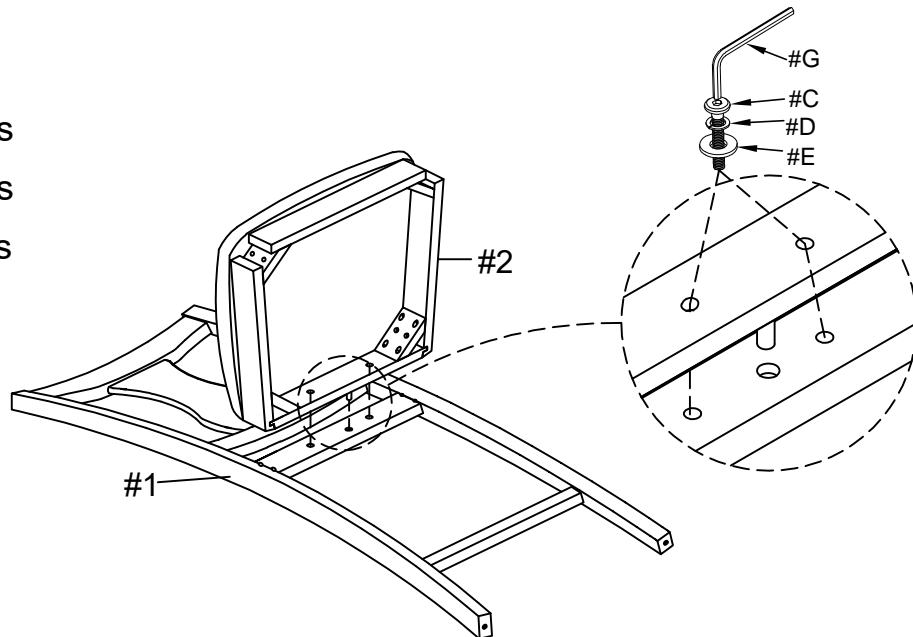

2

Prepare 4 bolts assembly by Spring Washer (#D), then flat washer (#E) onto bolts (#A). Secure cornerholes holes of seat frame (#3) to chair back (#1) by using bolts (#A). Fully tighten bolts (#A.C).

Hardware #A X 4pcs

Hardware #D X 4pcs

Hardware #E X 4pcs

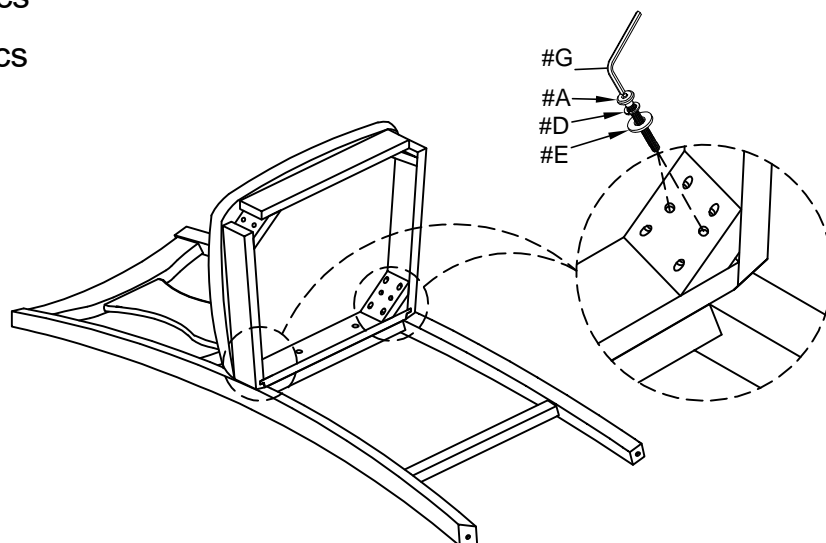

ASSEMBLY INSTRUCTIONS

3

Prepare 4 bolts assembly by Spring Washer (#D), then flat washer (#E) onto bolts (#B). Align front legs (#4) to the holes of the chair frame (#3). Secure by using bolts (#B)

- Part #4 X 2pcs
- Hardware #B X 4pcs
- Hardware #D X 4pcs
- Hardware #E X 4pcs

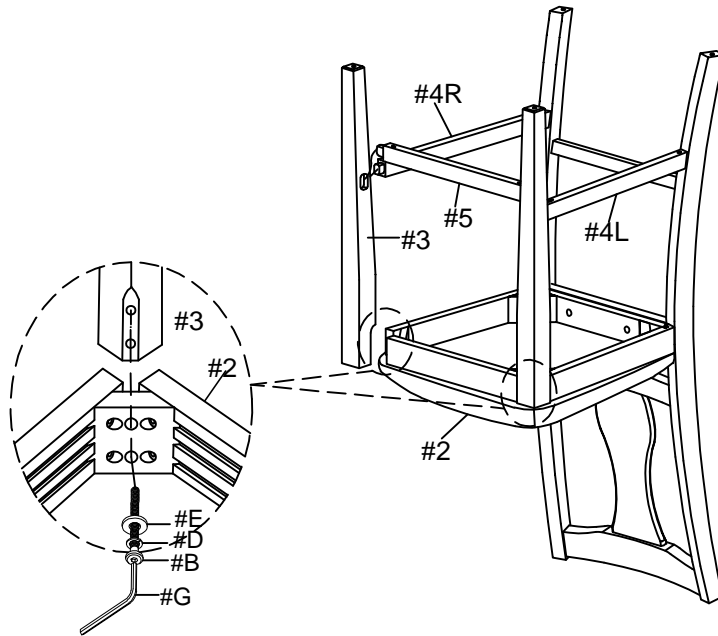

4

- Part #4 X 2pcs
- Part #5 X 1pc
- Hardware #G X 6pcs

Prepare 6 screws (#G) assemble the seat cushion (#3) then tighten the screws

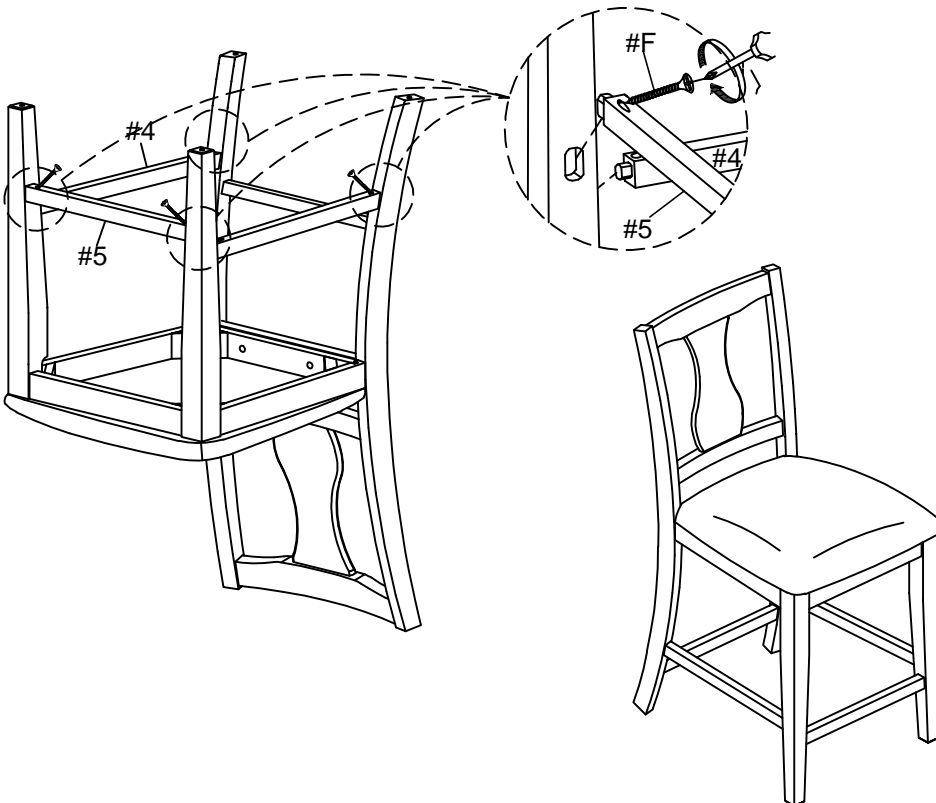

ASSEMBLY COMPLETED



Please ensure the furniture rests on even and flat surface. If the product wobbles or feels loose, double-check all bolts and/or screws are properly tightened and secured.



Keep this handy!

Please retain this instruction manual and any order-related information for future reference.



Lift, don't drag!

To avoid damage to product please always LIFT the product when transporting or adjusting the placement.