

Assembly Instructions



Assembly Instructions

INSTALLATION GUIDE

ONE PERSON ASSEMBLY: 15 MINUTES (APPROXIMATE)

TOOLS REQUIRED: ALLEN WRENCH (PROVIDED)

BEFORE ASSEMBLY

1. Remove all packaging materials, staples and packing straps from the carton.
2. Confirm with Parts Checklist in Page 3.

ATTENTION

1. Leave sufficient room for assembly.
2. Do not assemble on the ground that may hurt the product.
3. Do not over-tighten any fittings as it may cause damage.
4. **DO NOT USE POWER TOOLS TO ASSEMBLE THIS PRODUCT.**
5. Do not sit or stand on it before the assembly is complete.

DAILY MAINTENANCE

1. Recommended for indoor use only.
2. Wipe with a soft, dry cloth. Keep away from abrasives and household cleaners.
3. Check all the fittings periodically and re-tighten if necessary. Do not use the product if any part is damaged or broken.

Office Desk Chair Warranty Policy

Office desk chairs are warranted from the date of purchase due to material and workmanship factors. Details as follows:

1 YEAR on all unmovable metal parts;

1 YEAR on upholstered PU leather and foam;

1 YEAR on component parts including control mechanism, gas cylinder, wood, plastic parts, base and casters.

To make a warranty claim, please contact with model number, purchase proof, problem descriptions as well as pictures that shows the problem clearly.

Problem verified, will:









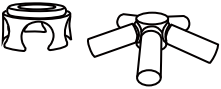
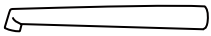

a) Send replacement parts.

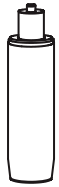
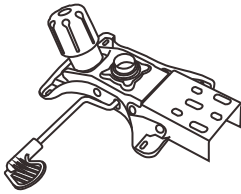
b) Send a new product if necessary, customer need to return the original item to our warehouse. Return freight will be undertaken

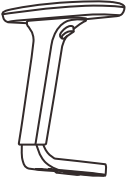
RETURN POLICY

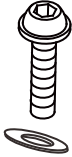
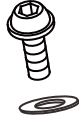
30 Days Free Return Policy after receiving the product is available. Offers prepaid return labels and undertake the return freight.

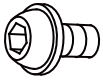
PARTS CHECK LIST

 <p>Ax1</p>	 <p>Bx5</p>	 <p>Cx5</p>	 <p>Dx1</p>	 <p>Ex1</p>	 <p>Fx1</p>
 <p>Gx2</p>	 <p>Hx1</p>	 <p>Ix4(M6 x 35mm + φ15 x φ7.5 x T1mm)</p>	 <p>Jx2(M6 x 40mm + φ15 x φ7.5 x T1mm)</p>	 <p>Kx4(M6 x 25mm + φ15 x φ7.5 x T1mm)</p>	 <p>Lx3(M8x25mm+φ13 x φ8xT2.5mm+ φ20 x φ8.5 xT1.5mm)</p>
 <p>Mx10(M6 x 12mm)</p>	 <p>Nx1</p>	 <p>Ox4</p>			

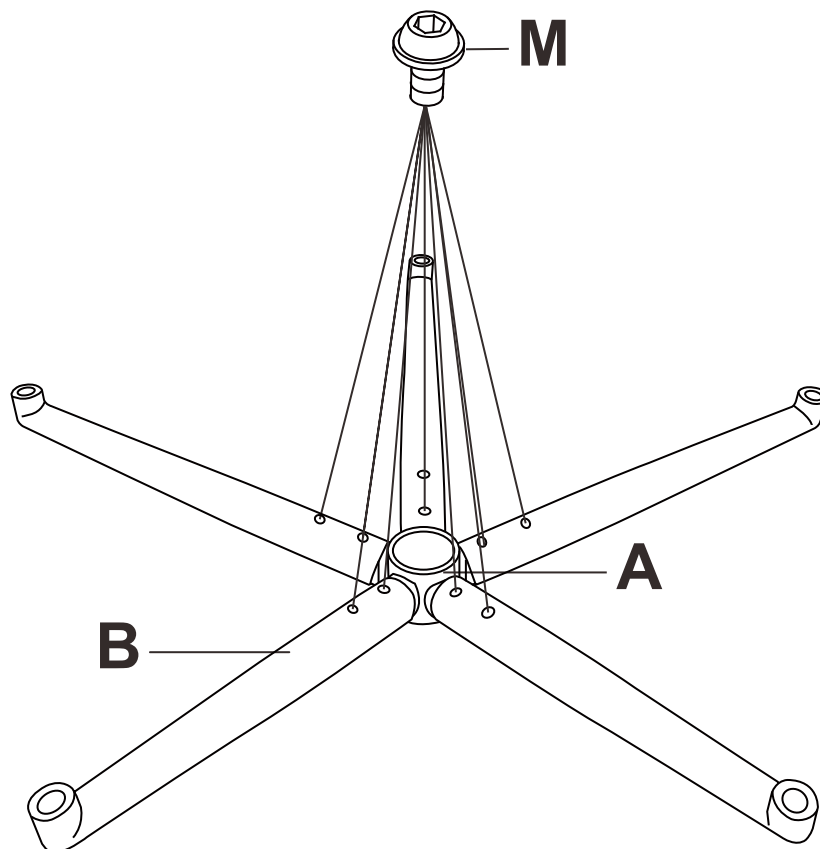

Step 1: Insert part **B** into Part **A** and screwed with **Mx10**.

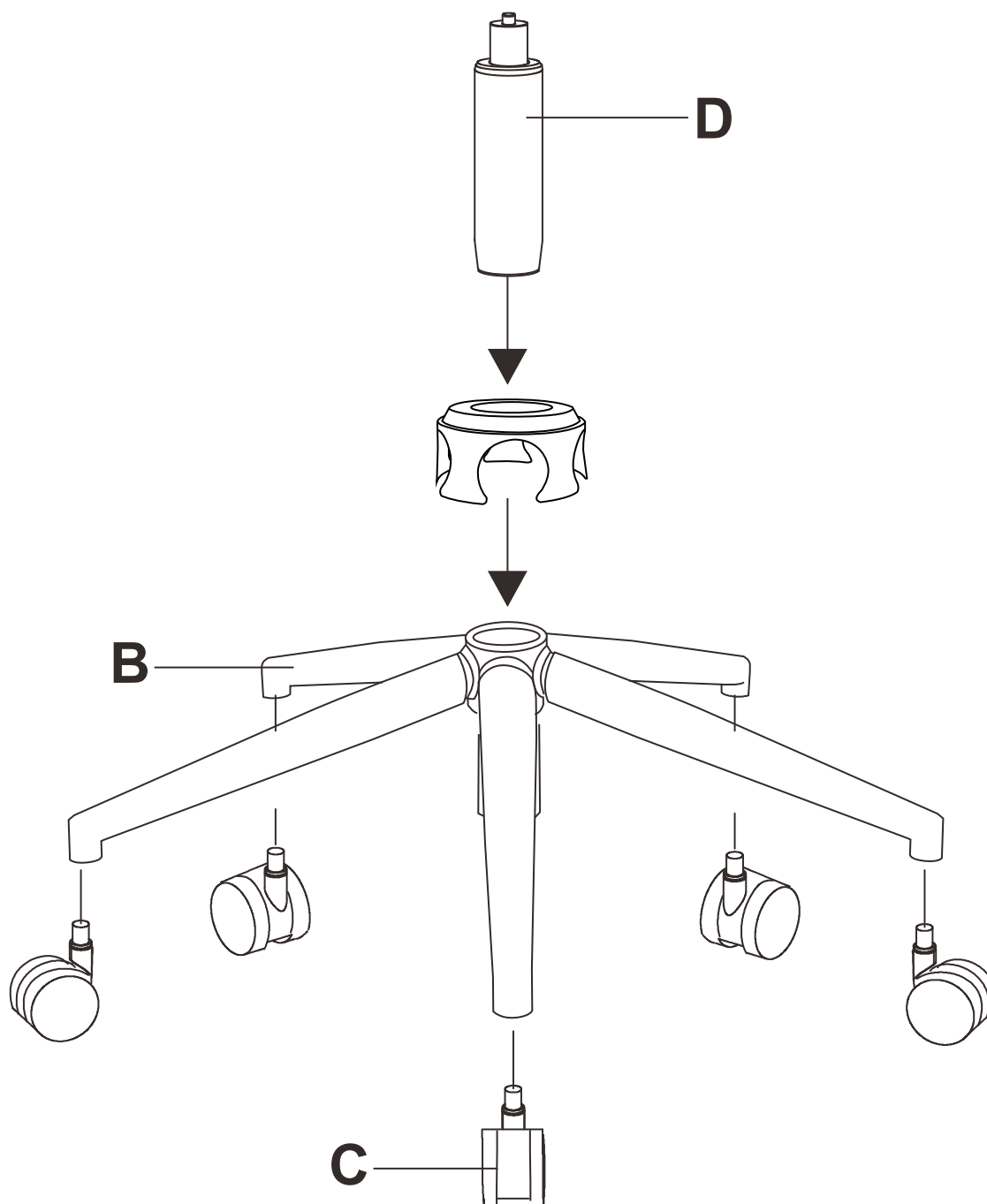

Step 2: Insert Casters **Cx5** into the base with force. Insert the gap **A** into the center of the base. Insert the gas lift **D** into the center of the base.

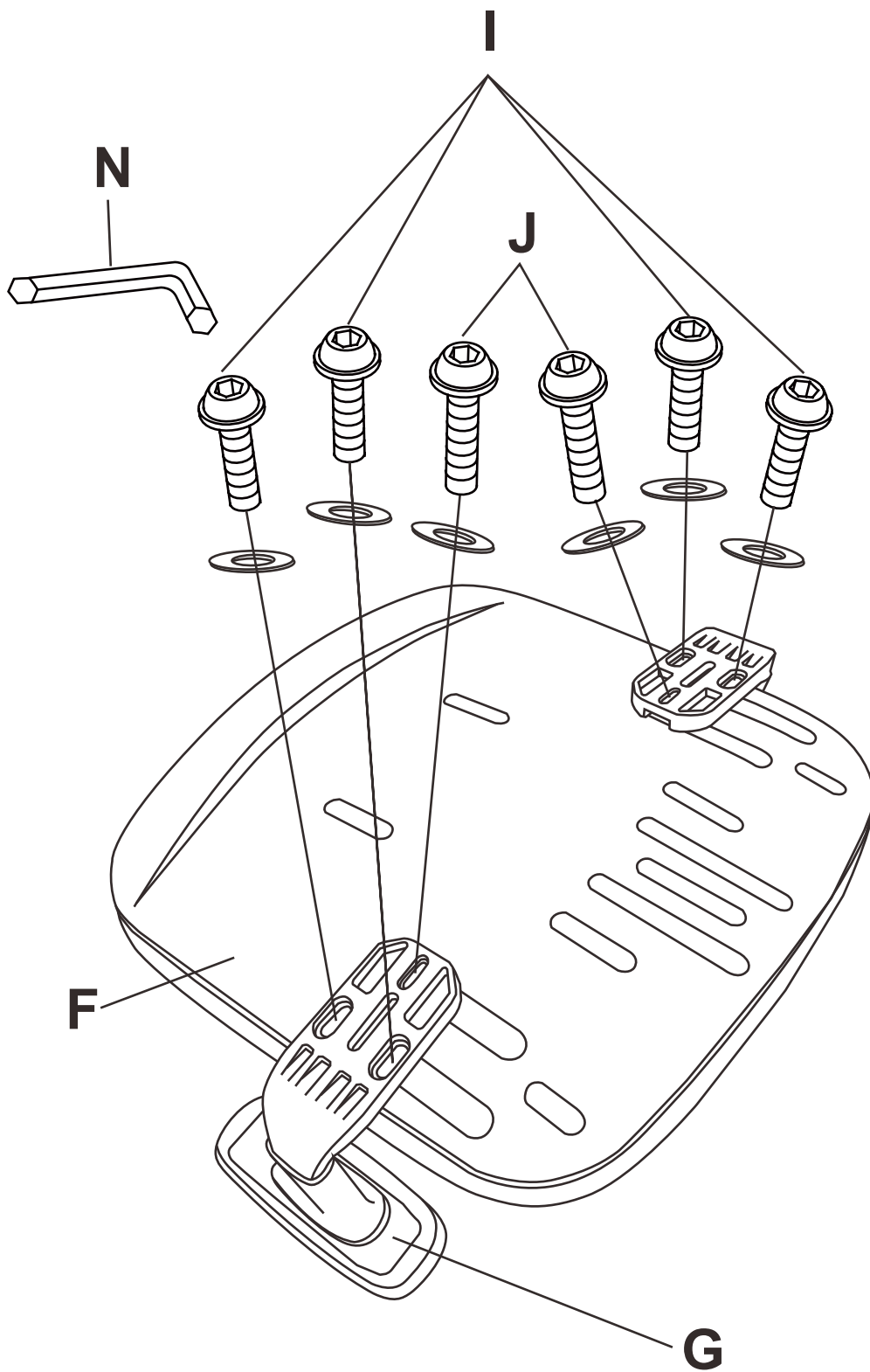

Step 3: Attach the Armrests **Gx2** to the Seat **F** with Screws **Ix4** and **Jx2** as the picture.

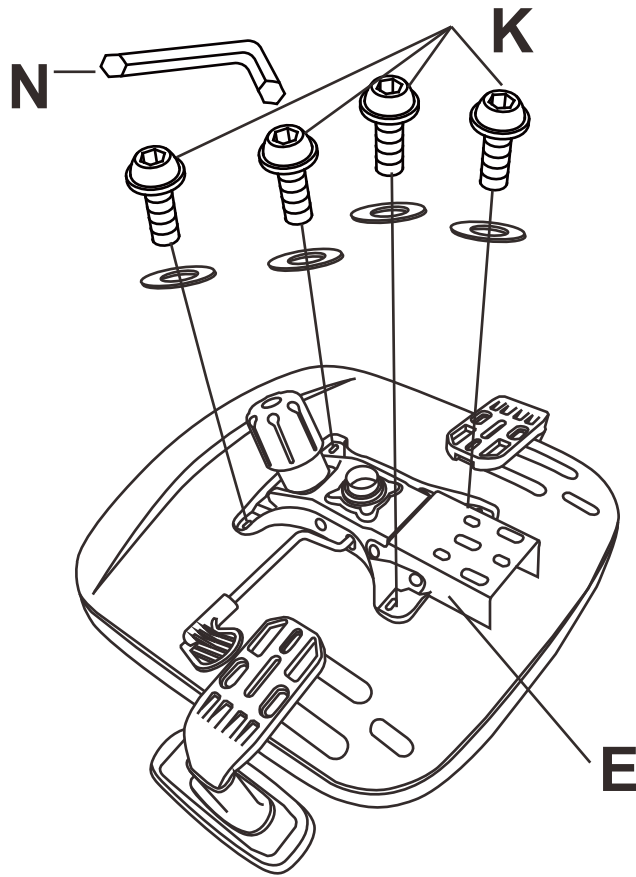

Step 4: Attach the tilt mechanism **E** to the Seat **F** with Screws **Kx4** .
Please note the orientation of the front of the seat and the mechanism.

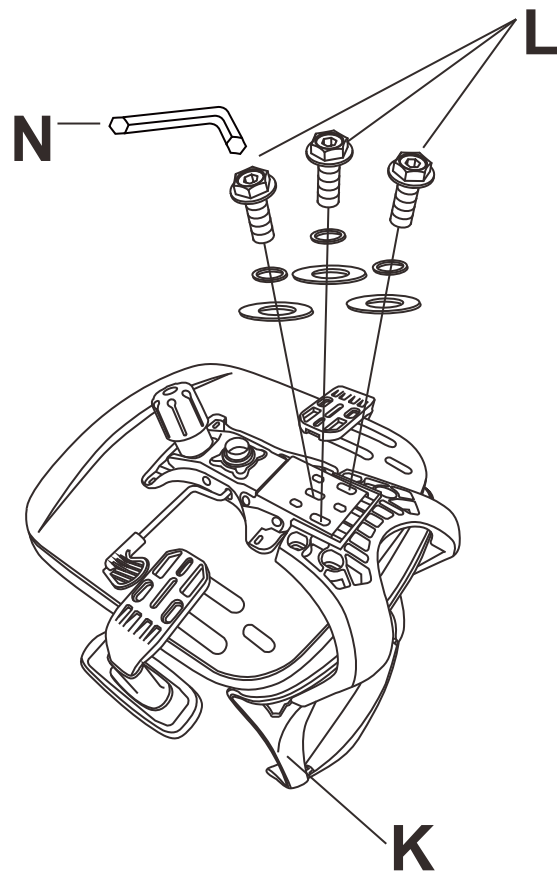

Step 5: Attach the Back **H** to the Seat **F** with Screws **Lx4**.

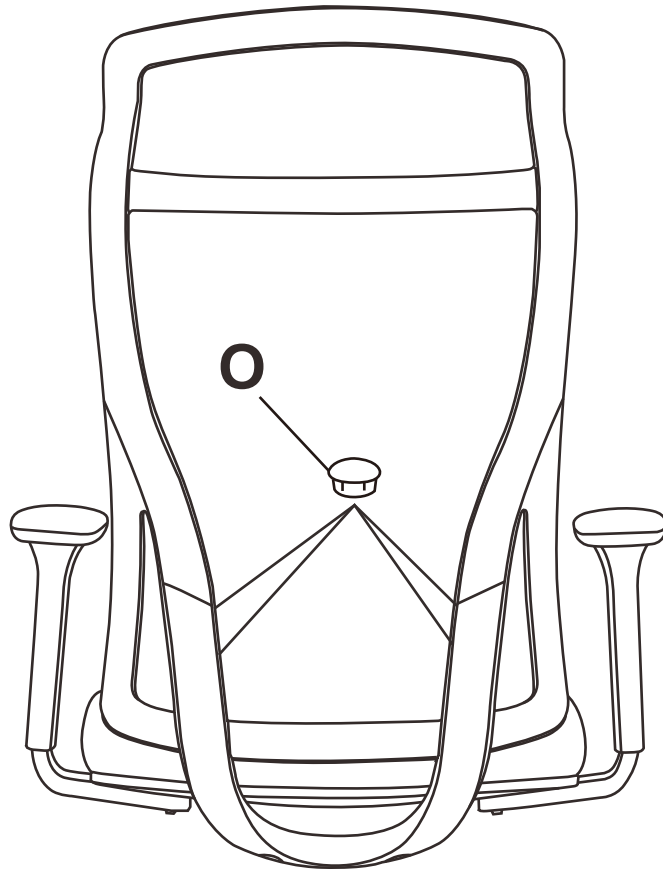

Step 6: Insert the Gap **Ox4** into the Back F as the picture.

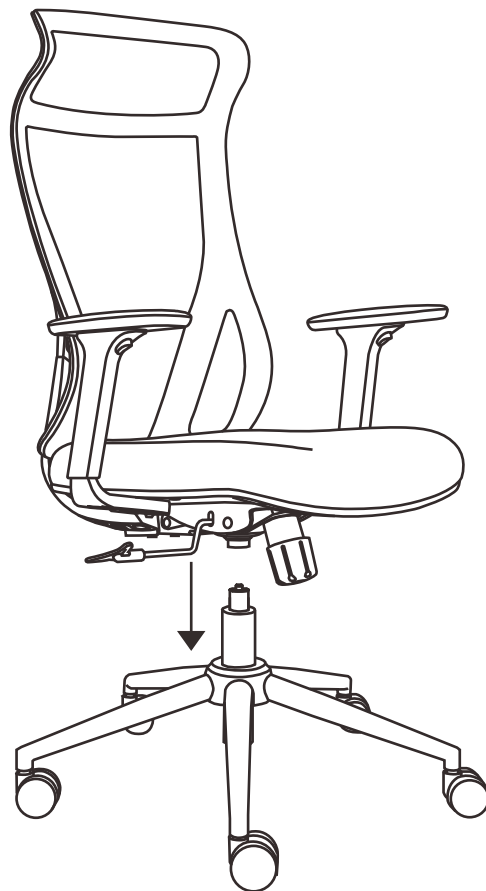

Step 7: Attach the assembled seat to the assembled base by aligning the hole in the tilt mechanism to the top of the gas lift. Push down firmly to secure.



Step 8: Enjoy your new chair .

After-sales Support

We are working on delivering you a perfect product, but sometimes the parts may still be damaged or lost in transit.

If any parts are damaged or lost, please contact us immediately, perfect solutions will be offered to fix the issues.