

Pure & Easy

ASSEMBLY INSTRUCTIONS

FTLFCT-0170 FTLFCT-0171 FTLFCT-0172
FTLFCT-0173 FTLFCT-0174 FTLFCT-0175

CZSS-V2

NOTICE

IMPORTANT, RETAIN FOR FUTURE REFERENCE: READ CAREFULLY
WICHTIG, FÜR SPÄTERE NACHSCHLAGE AUFBEWAHREN: SORGFÄLTIG LESEN
IMPORTANTE, GUARDAR PARA REFERENCIA FUTURA: LEER ATENTAMENTE
IMPORTANTE, CONSERVARE PER RIFERIMENTI FUTURI: LEGGERE ATTENTAMENTE
IMPORTANT, À CONSERVER POUR RÉFÉRENCE FUTURE : LIRE ATTENTIVEMENT

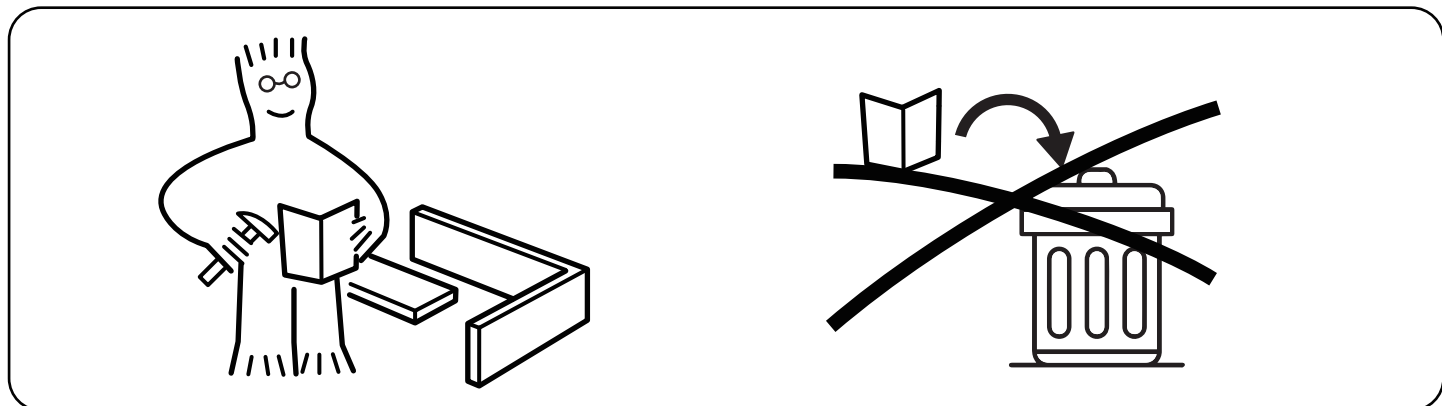

Assemble on a flat, clean and soft surface.
Auf einer flachen, sauberen und weichen Oberfläche zusammenbauen.
Assembler sur une surface plate, propre et douce.
Assemblare su una superficie piatta, pulita e morbida.
Ensamblar sobre una superficie plana, limpia y suave.

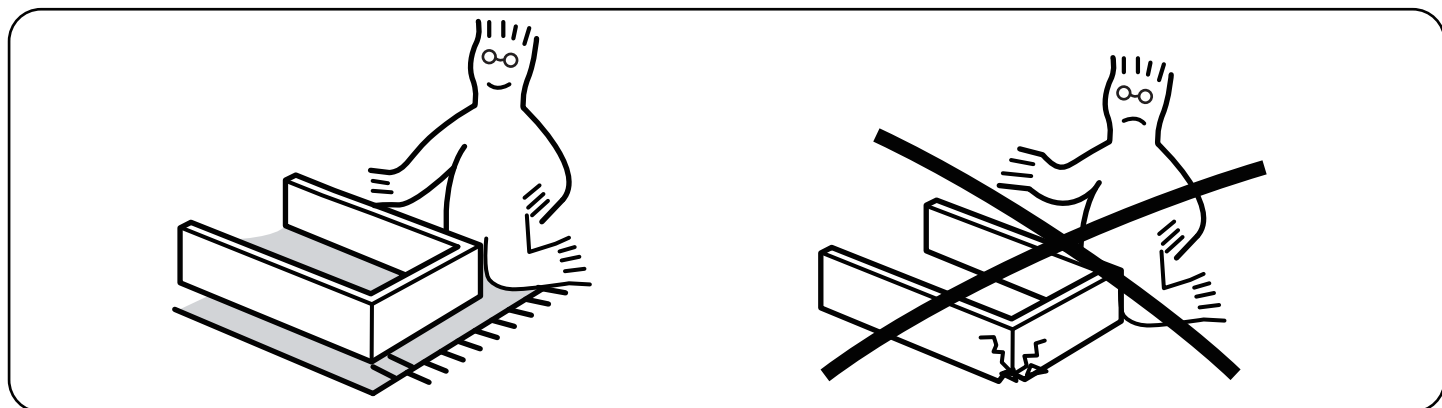

Professional installation is highly recommended.
Eine professionelle Installation wird dringend empfohlen.
Une installation professionnelle est fortement recommandée.
Si raccomanda vivamente l'installazione professionale.
Se recomienda altamente la instalación profesional.



Periodically Check That All Components Are Tightly Secured.
Überprüfen Sie Regelmäßig, Dass Alle Komponenten Fest Gesichert Sind.
Vérifiez Périodiquement Que Tous Les Composants Sont Bien Fixés.
Controllare Periodicamente Che Tutti I Componenti Siano Ben Fissati.
Verifique Periódicamente Que Todos Los Componentes Estén Bien Asegurados.

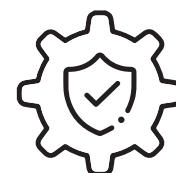



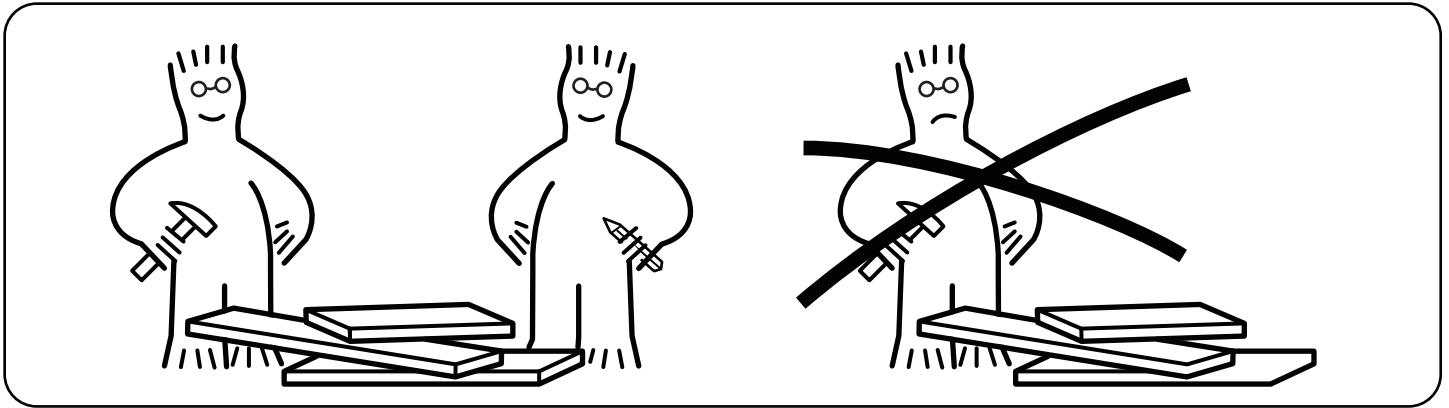

It is recommended that multiple people assemble this product.
Es wird empfohlen, dass mehrere Personen dieses Produkt zusammenbauen.
Il est recommandé que plusieurs personnes assemblent ce produit.
Si raccomanda che più persone assemblino questo prodotto.
Se recomienda que varias personas ensamblen este producto.

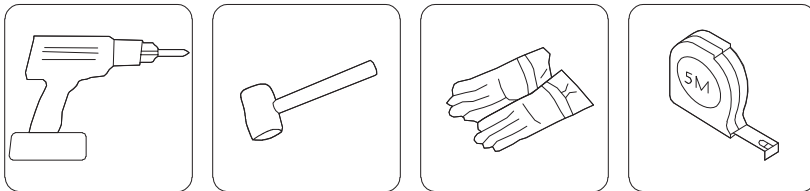



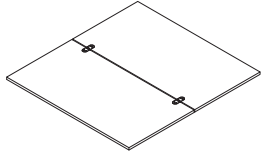
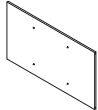
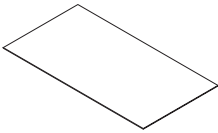
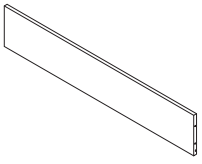
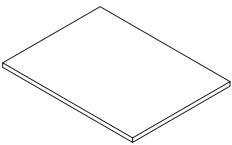

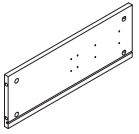
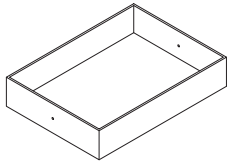
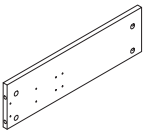
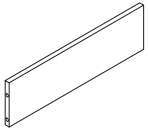
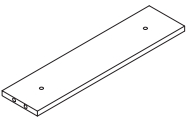
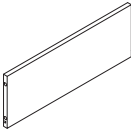
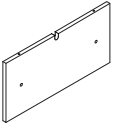
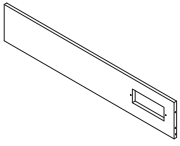
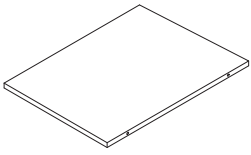



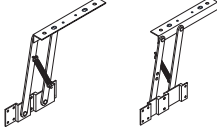

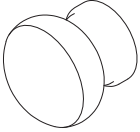
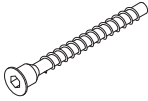
Please have the following auxiliary tools ready:

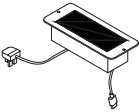
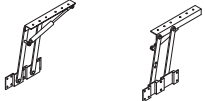

PARTS

Item no. Nr. N° d'article Articolo No. Artículo No.	Reference Image Referenzbild Image de référence Immagine di riferimento Imagen de referencia	Qty. Menge Qté. Qtà Cant.	Item no. Nr. N° d'article Articolo No. Artículo No.	Reference Image Referenzbild Image de référence Immagine di riferimento Imagen de referencia	Qty. Menge Qté. Qtà Cant.
1		X1	9		X1
2		X1	10		X1
3		X1	11		X4
4		X1	12		X1
5		X1	13		X1
6		X2	14		X1
7		X2	15		X1
8		X1	A		X24
				M6 X 35MM	

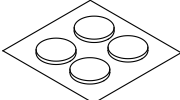
Item no. Nr. N° d'article Articolo No. Artículo No.	Reference Image Referenzbild Image de référence Immagine di riferimento Imagen de referencia	Qty. Menge Qté. Qtà Cant.	Item no. Nr. N° d'article Articolo No. Artículo No.	Reference Image Referenzbild Image de référence Immagine di riferimento Imagen de referencia	Qty. Menge Qté. Qtà Cant.
B	 φ12	X24	J	 J1 J2	X1
C	 M3.5 X 12MM	X46	K		X2
D	 M6.3 X 40MM	X12	L	 M4 X 8MM	X2
E	 M5 X 60MM	X12	M		X1
F	 M6 X 10MM	X4	N		X1
G	 G1 G2	X1	O	 □□□□	X1
H	 M8	X4	P		X2
I	 M4	X1	Q		X1

EXPLODED VIEW

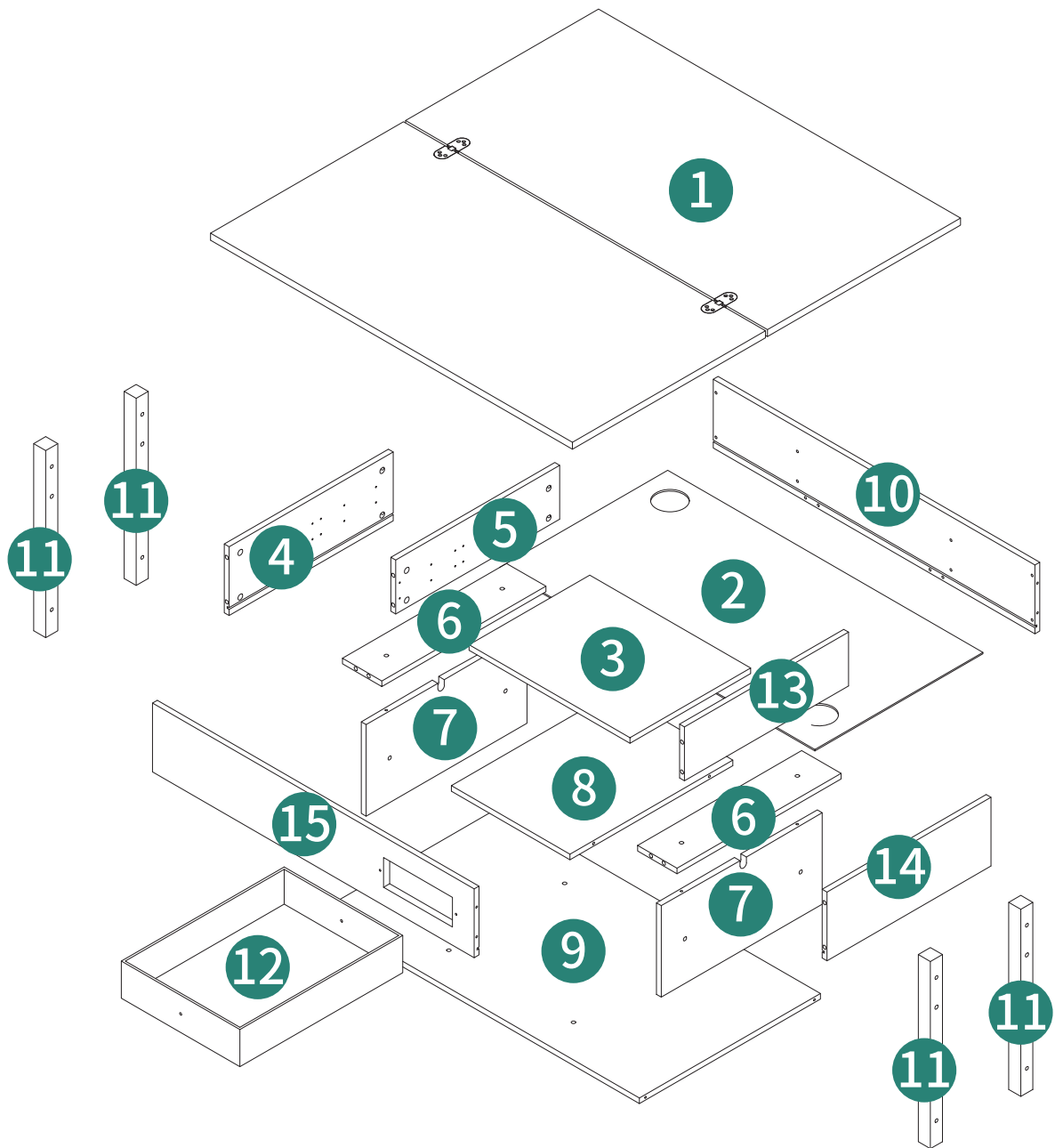

ASSEMBLY

1

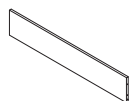

⑩ 1pc

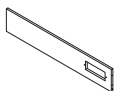

⑮ 1pc



Ⓐ 24pcs

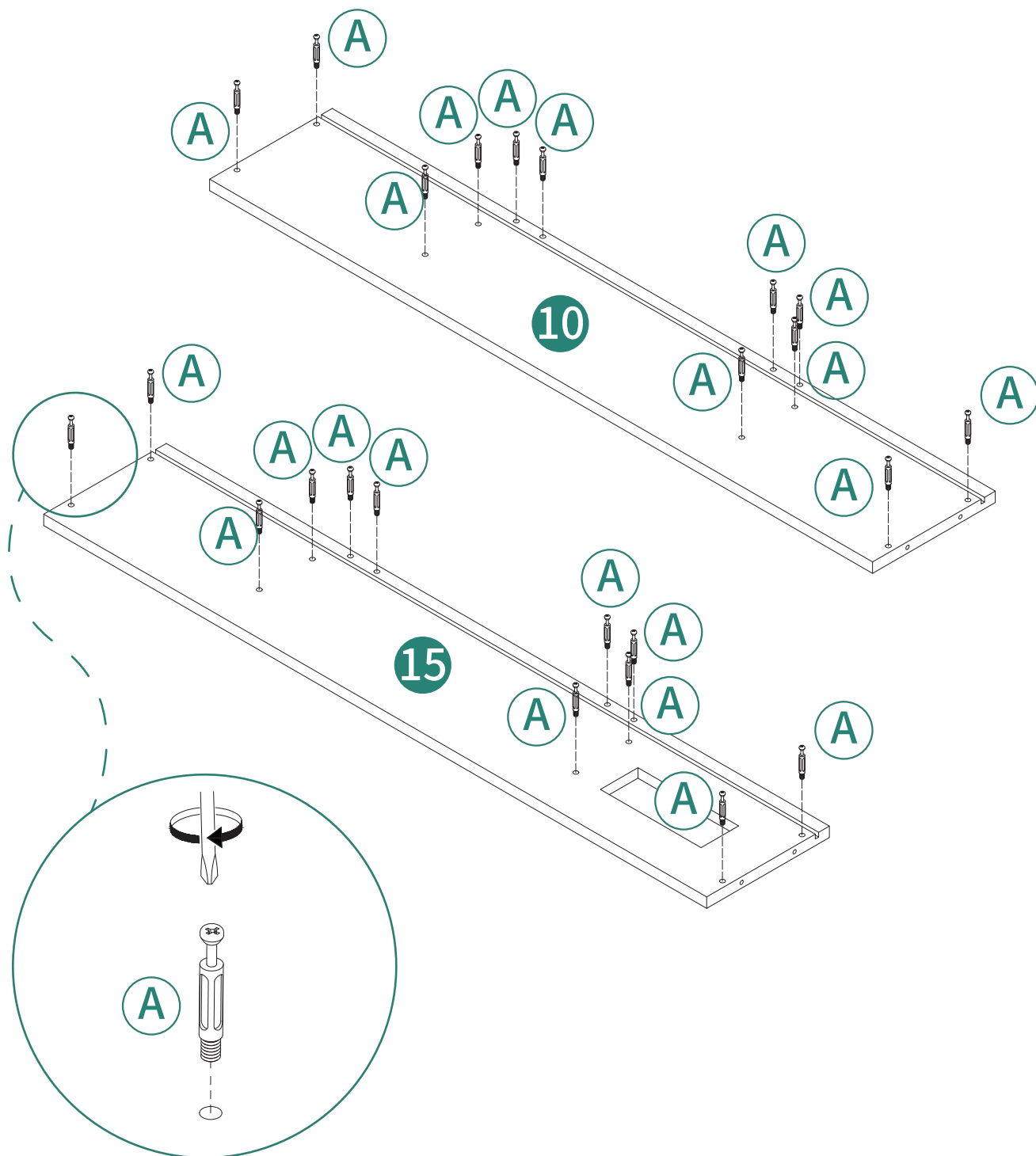

2

X2

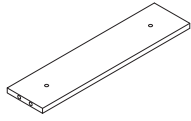

⑥ 2pcs

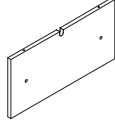

⑦ 2pcs

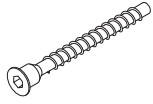

ⓓ 4pcs

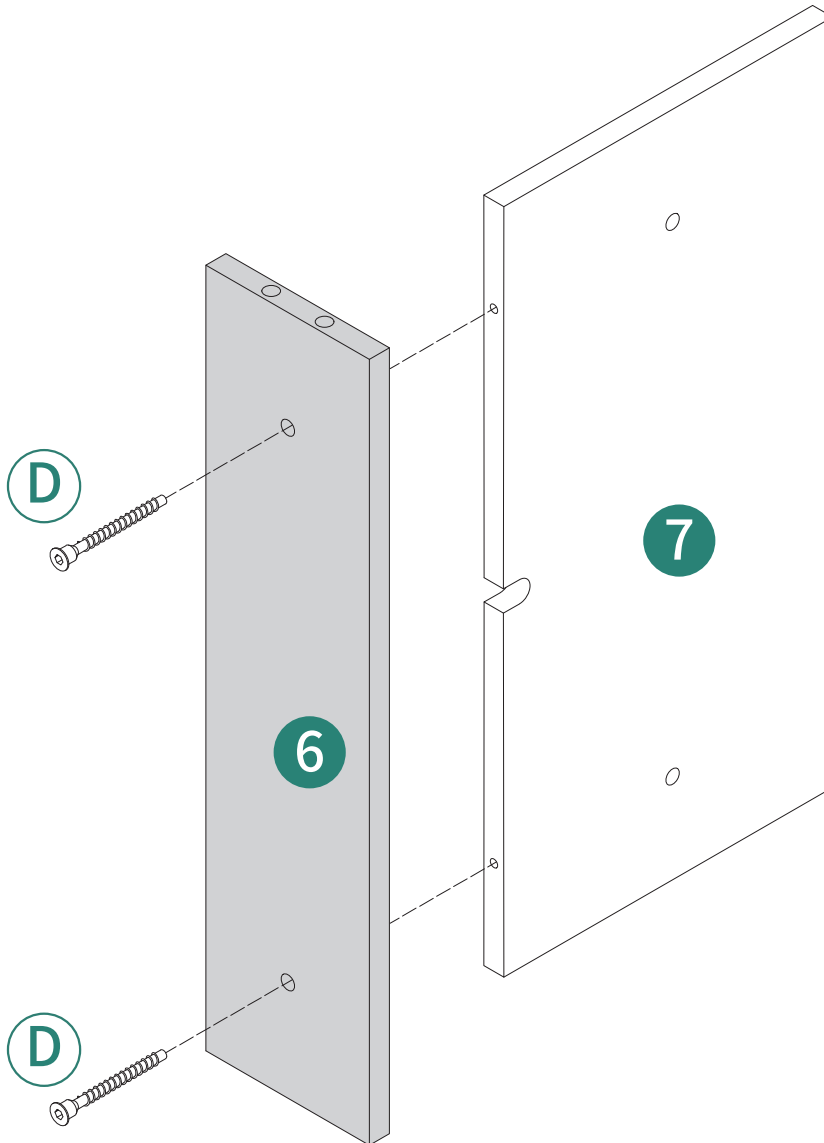

3



Ⓑ 4pcs

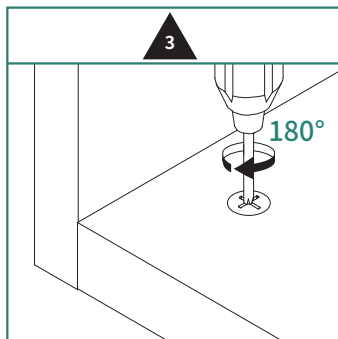
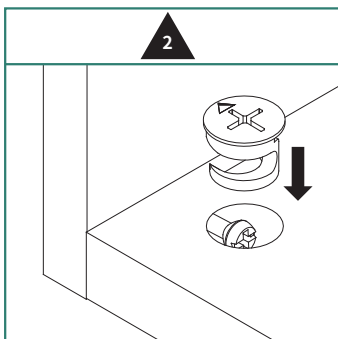
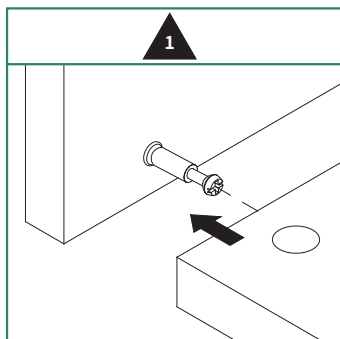
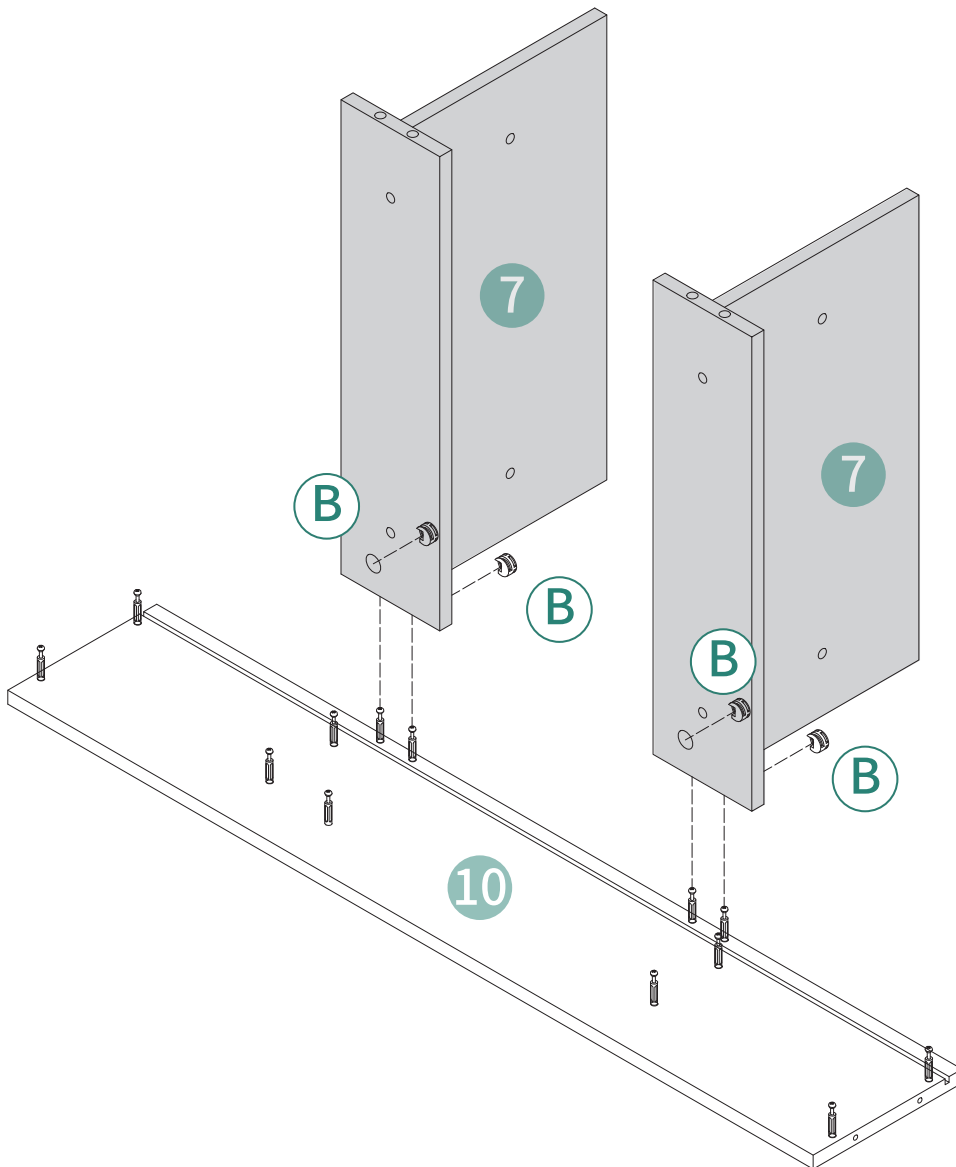

4



Ⓑ4pcs

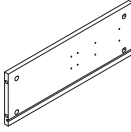

④1pc

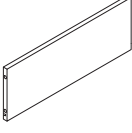

⑭1pc

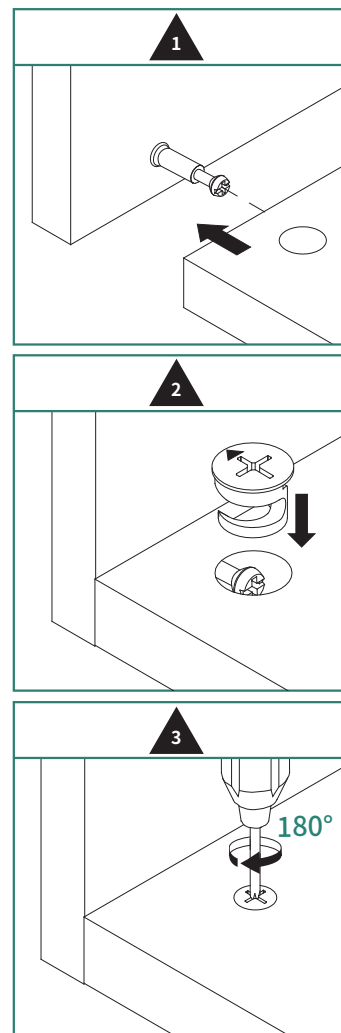
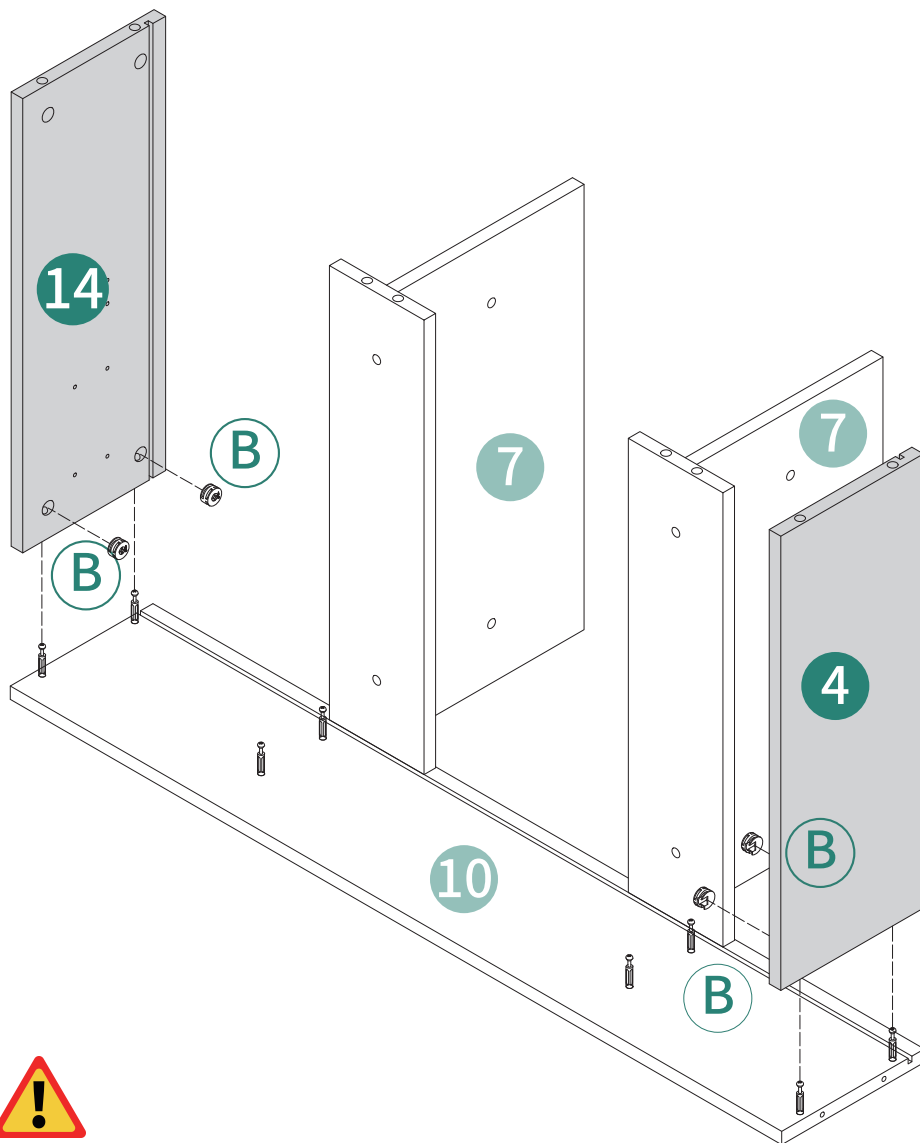

When installing, pay attention to the orientation of the holes in part 4 and part 15 as illustrated in the diagram.
 Bei der Installation achten Sie auf die Ausrichtung der Löcher in Teil 4 und Teil 15, wie im Diagramm dargestellt.
 Lors de l'installation, veuillez faire attention à l'orientation des trous dans la pièce 4 et la pièce 15, comme illustré dans le schéma.

Durante l'installazione, prestare attenzione all'orientamento dei fori nella parte 4 e nella parte 15 come illustrato nel diagramma.

Al instalar, preste atención a la orientación de los agujeros en la pieza 4 y la pieza 15, como se muestra en el diagrama.

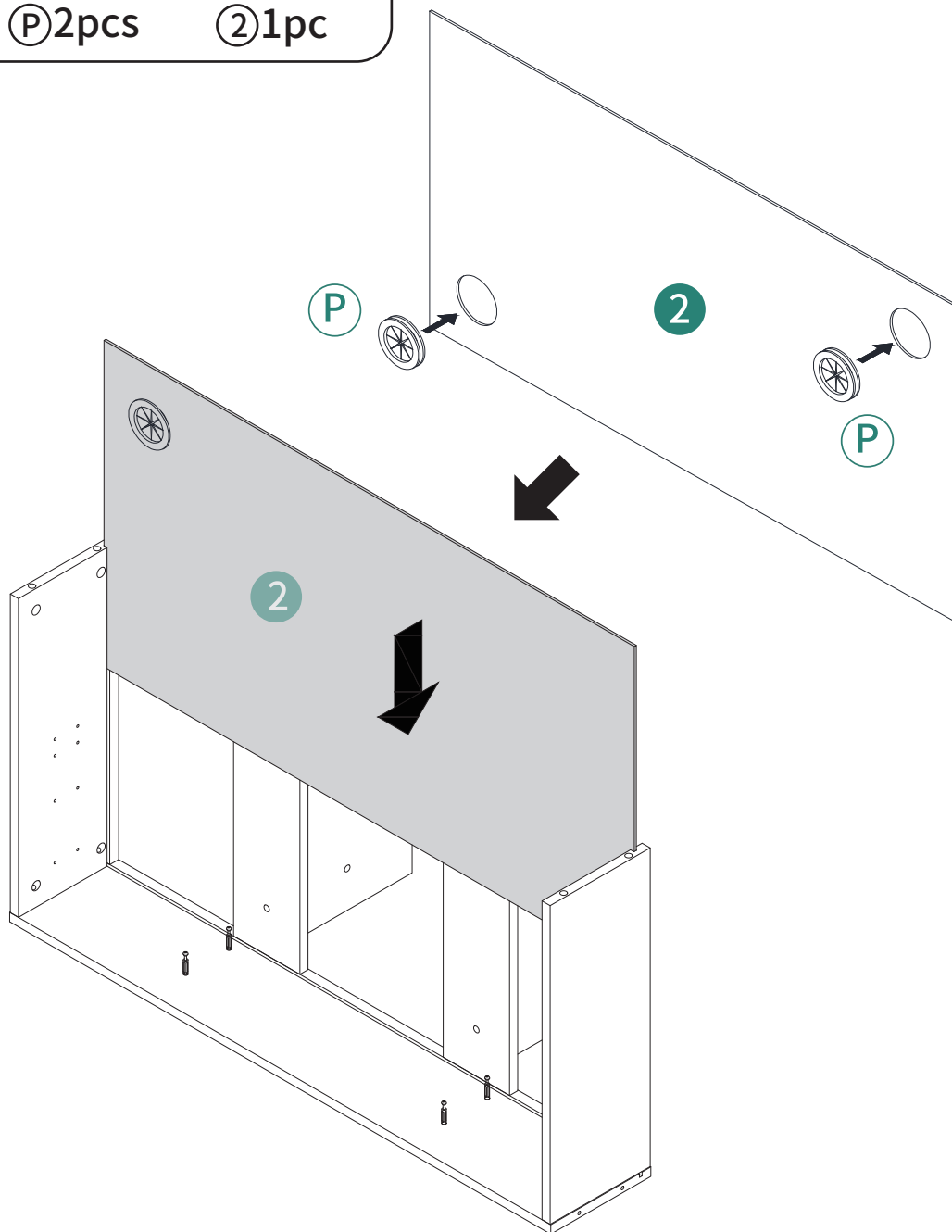
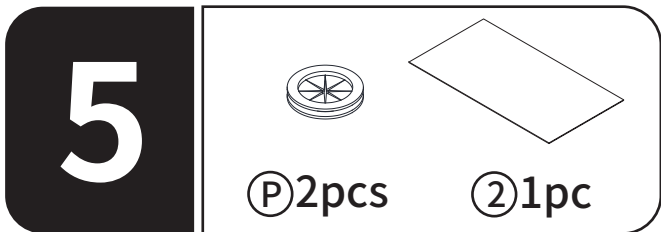

When installing, pay attention to the orientation of the holes in part 2.

Bei der Installation achten Sie auf die Ausrichtung der Löcher in Teil 2.

Lors de l'installation, veuillez faire attention à l'orientation des trous dans la pièce 2.

Durante l'installazione, prestare attenzione all'orientamento dei fori nella parte 2.

Al instalar, preste atención a la orientación de los agujeros en la pieza 2.

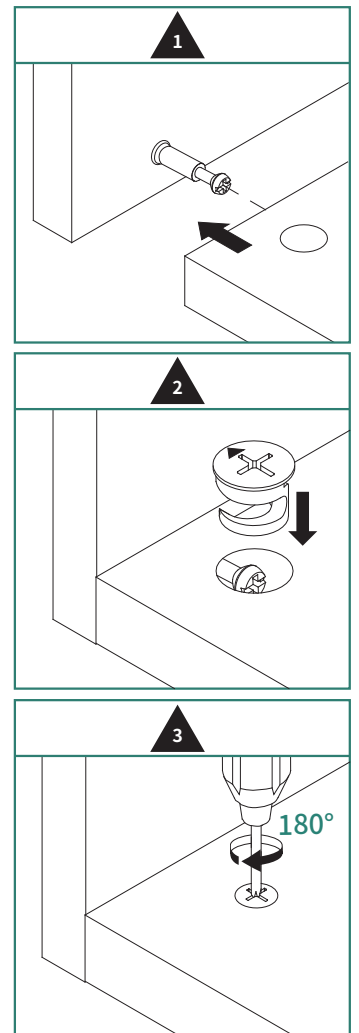
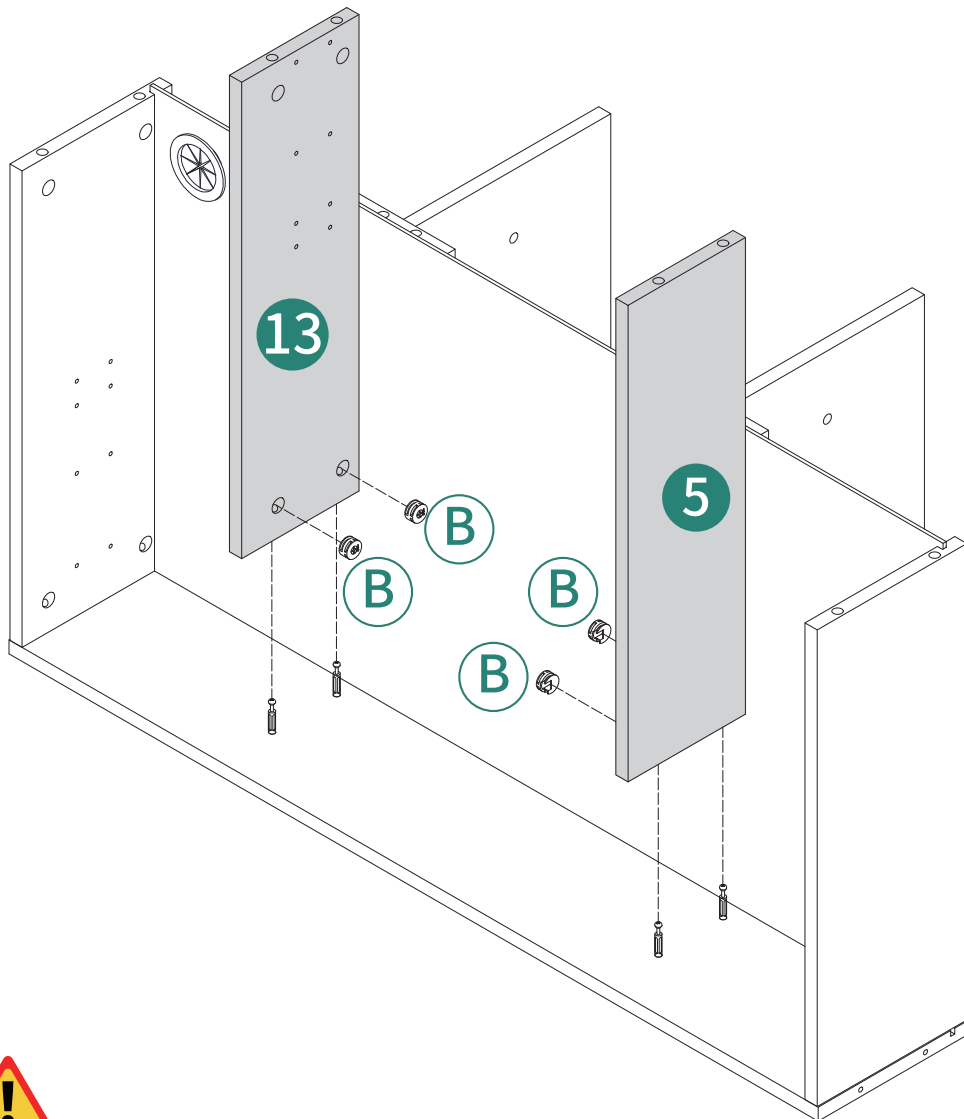
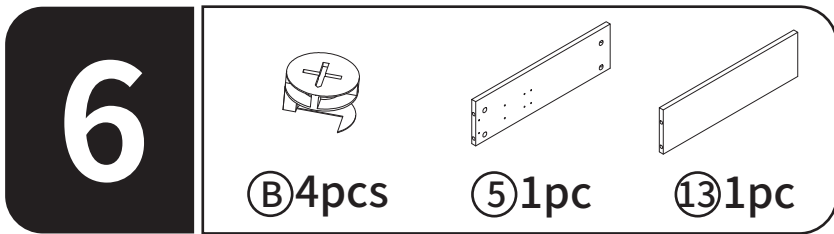

When installing, pay attention to the orientation of the holes in part 5 and part 14 as illustrated in the diagram.
 Bei der Installation achten Sie auf die Ausrichtung der Löcher in Teil 5 und Teil 14, wie im Diagramm dargestellt.
 Lors de l'installation, veuillez faire attention à l'orientation des trous dans la pièce 5 et la pièce 14, comme illustré dans le schéma.

Durante l'installazione, prestare attenzione all'orientamento dei fori nella parte 5 e nella parte 14 come illustrato nel diagramma.

Al instalar, preste atención a la orientación de los agujeros en la pieza 5 y la pieza 14, como se muestra en el diagrama.

7 
ⓑ12pcs

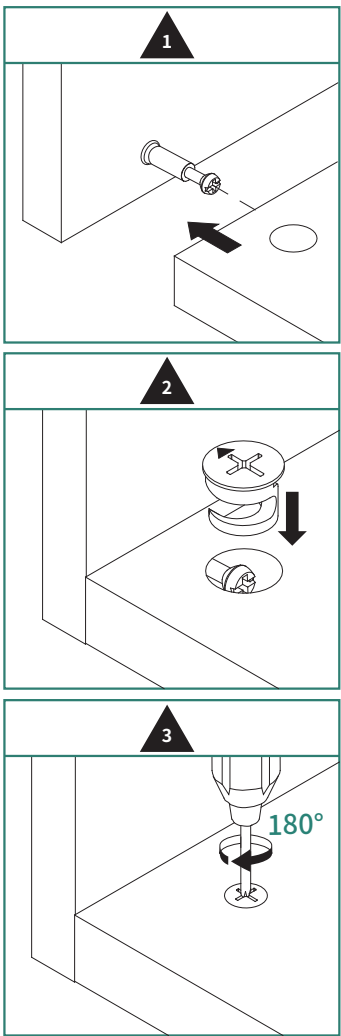
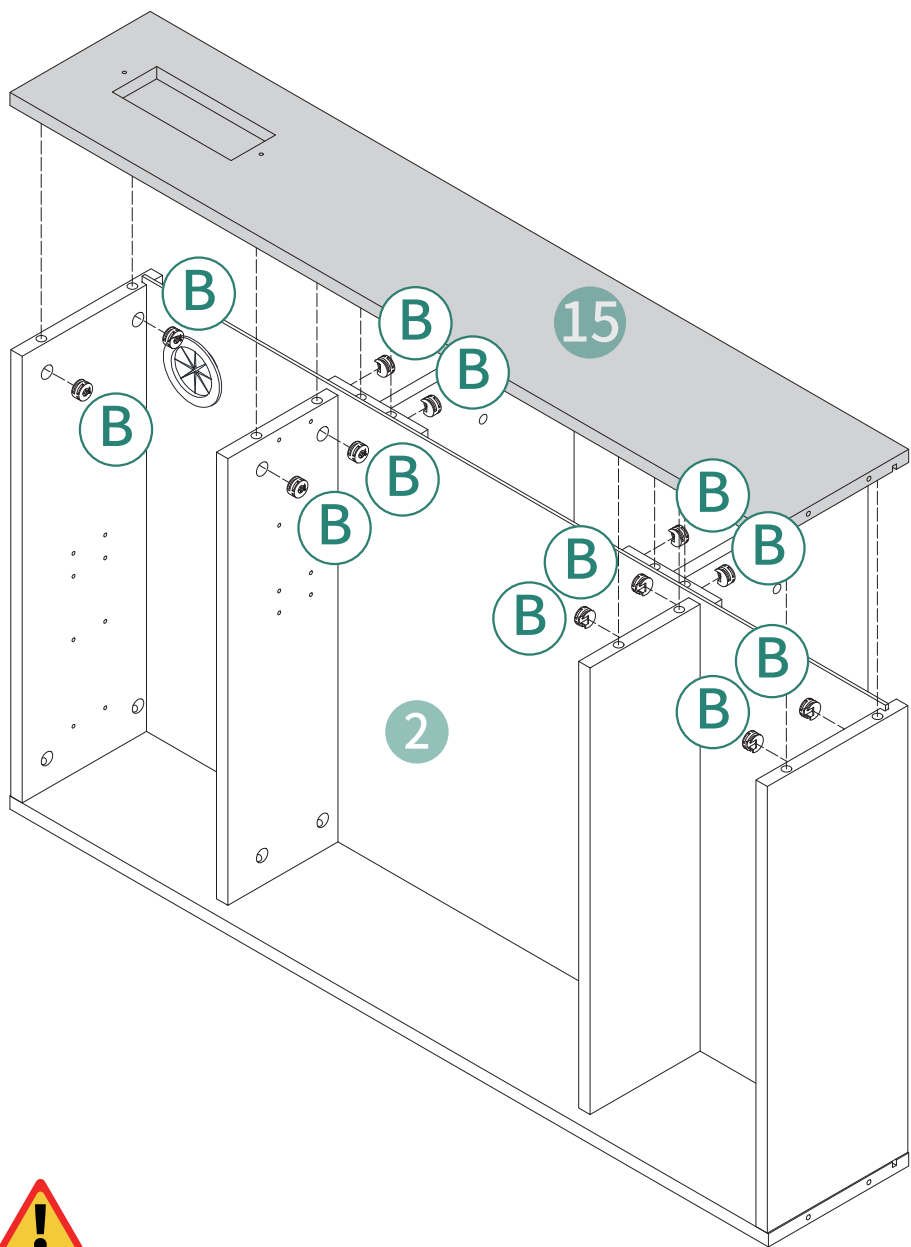

Ensure that the holes in part 16 and part 2 are aligned during installation.

Stellen Sie sicher, dass die Löcher in Teil 16 und Teil 2 während der Installation ausgerichtet sind.

Assurez-vous que les trous dans la pièce 16 et la pièce 2 sont alignés lors de l'installation.

Assicurarsi che i fori nella parte 16 e nella parte 2 siano allineati durante l'installazione.

Asegúrese de que los agujeros en la pieza 16 y la pieza 2 estén alineados durante la instalación.

8

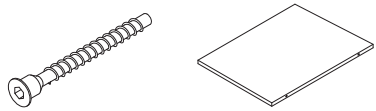

ⓓ4pcs Ⓢ1pc

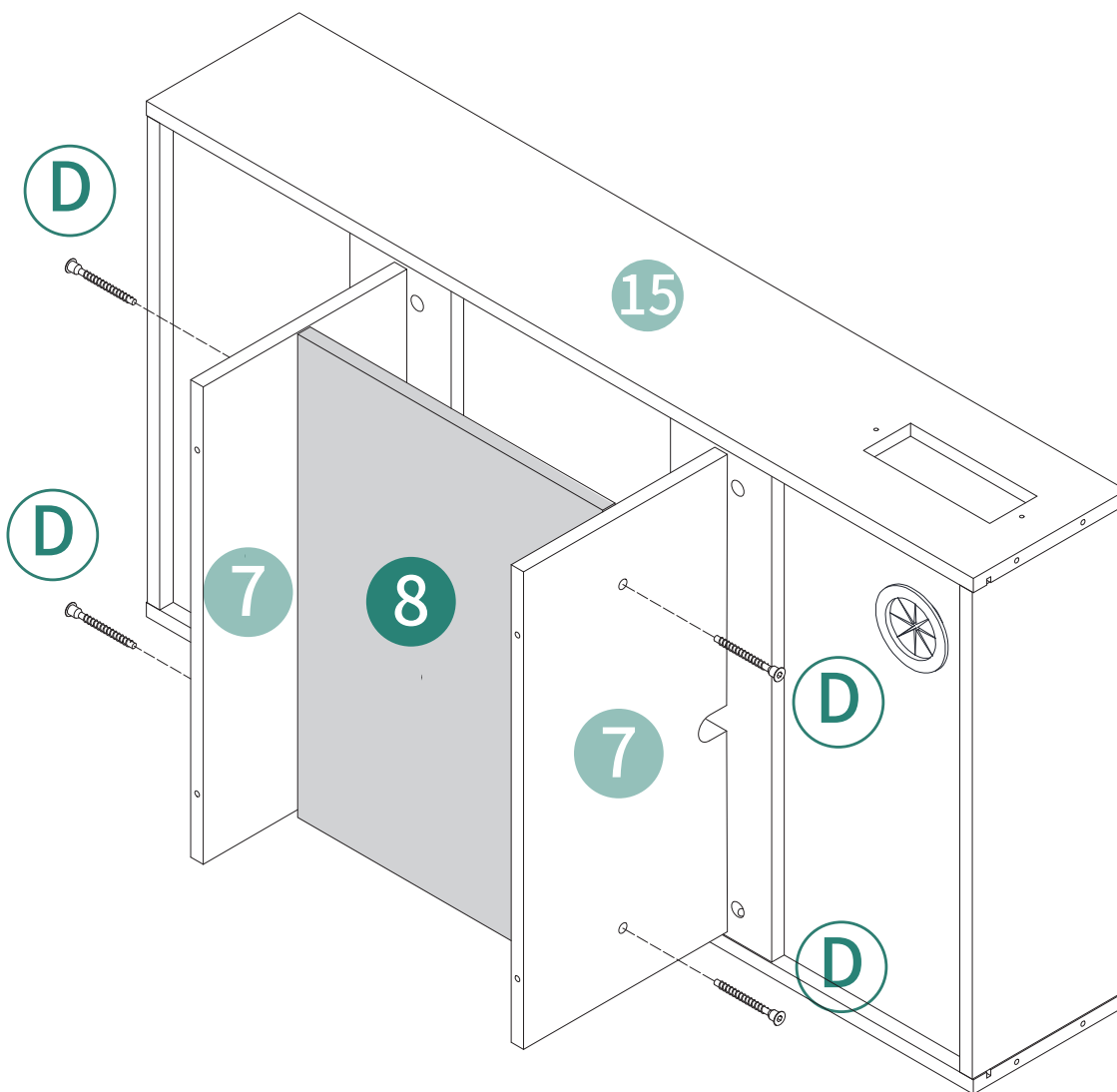

9



ⓓ4pcs ⑨1pc

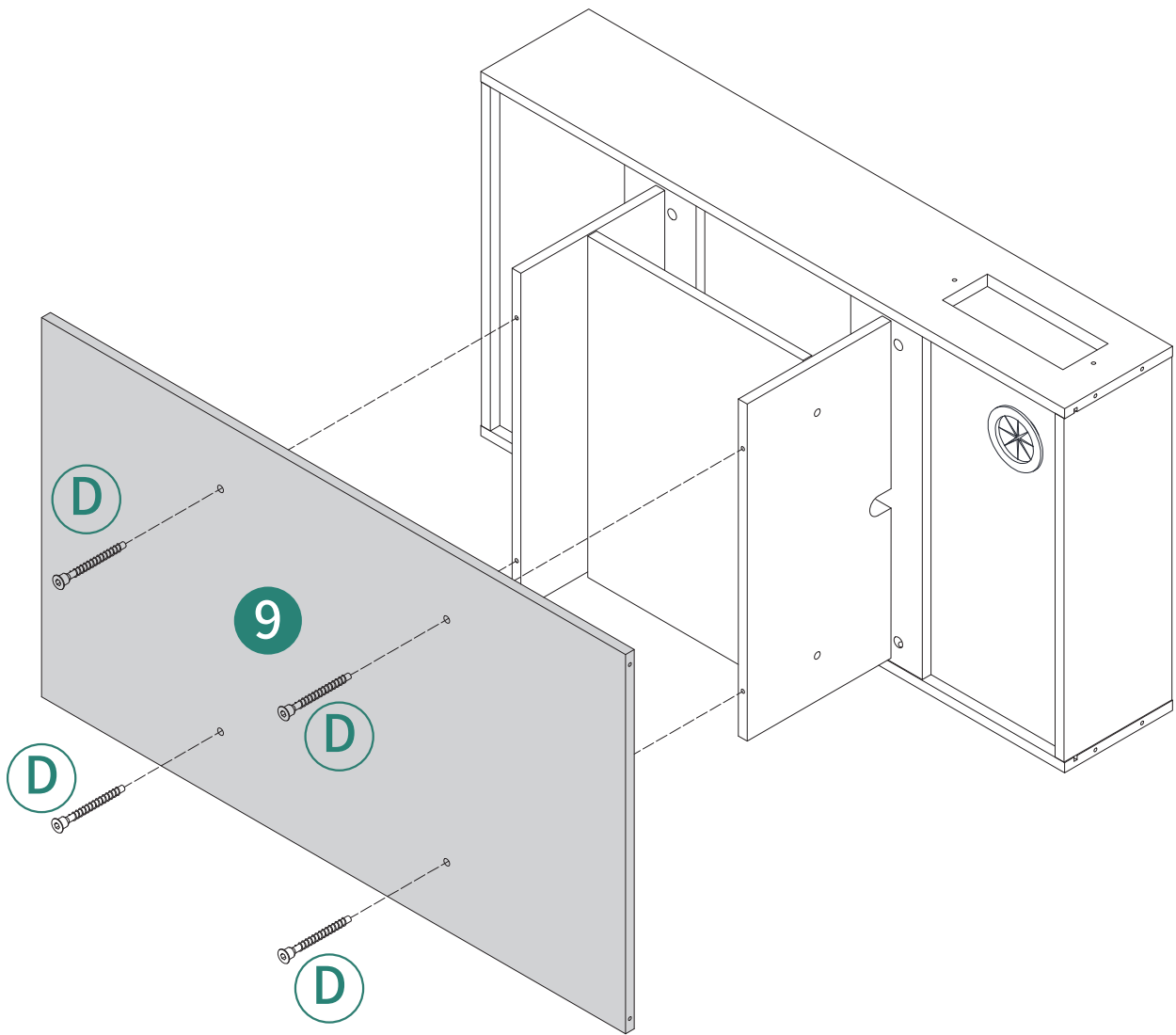

10

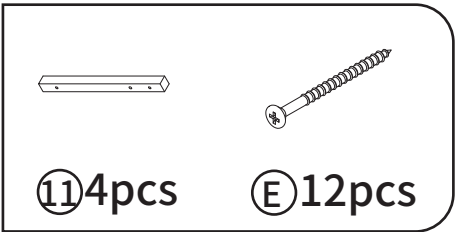

⑪ 4 pcs ⑤ 12 pcs

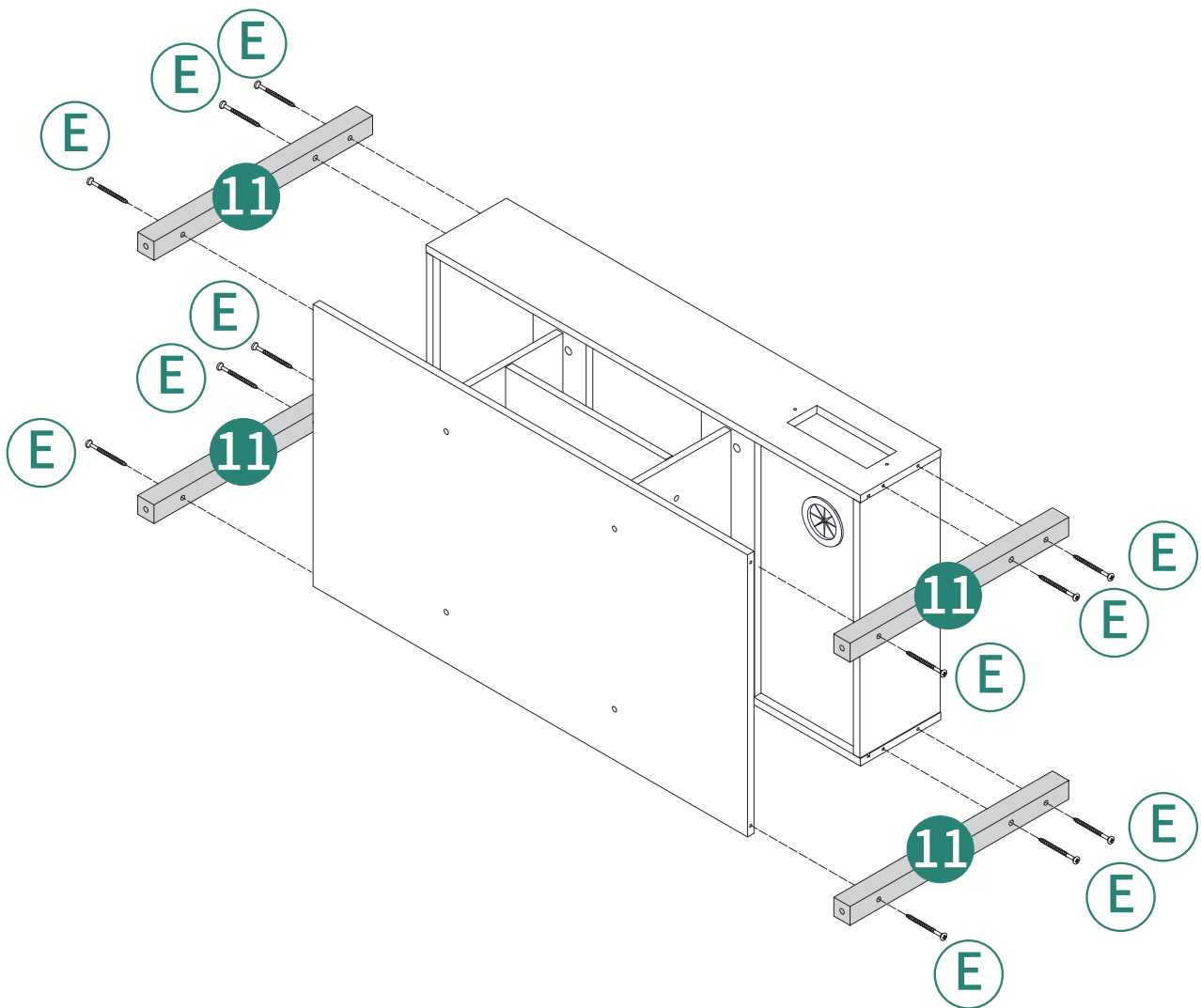

11



Ⓜ4pcs



⓪1pc

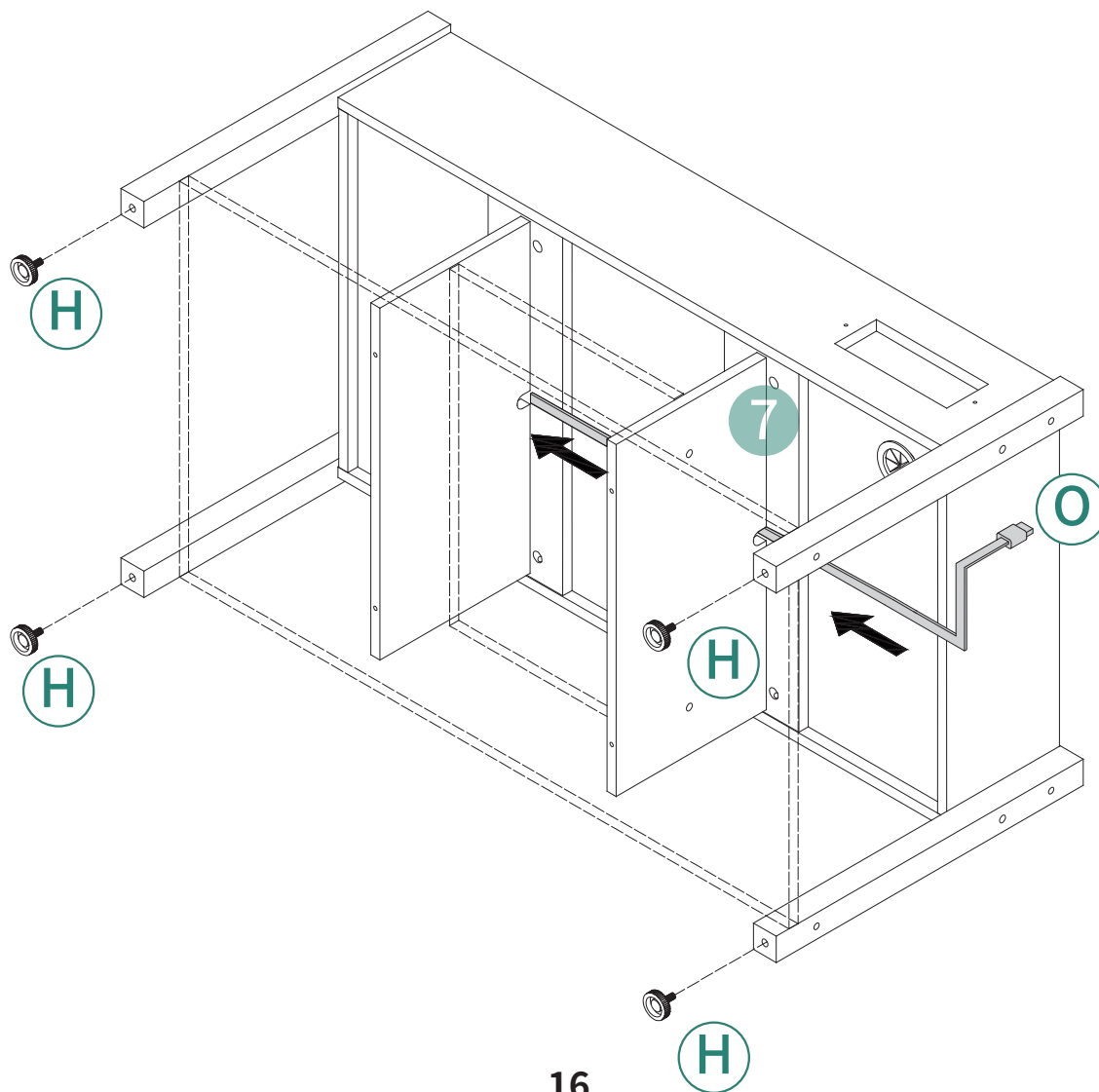
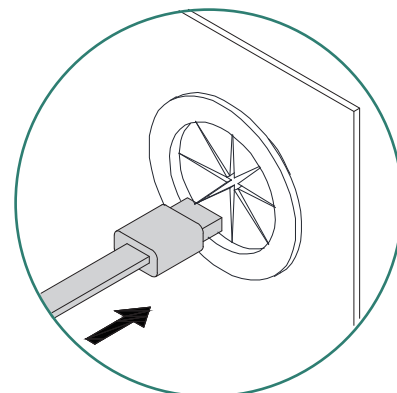
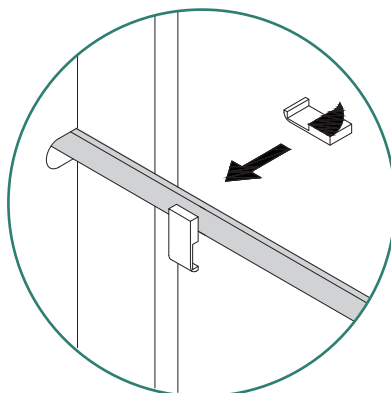
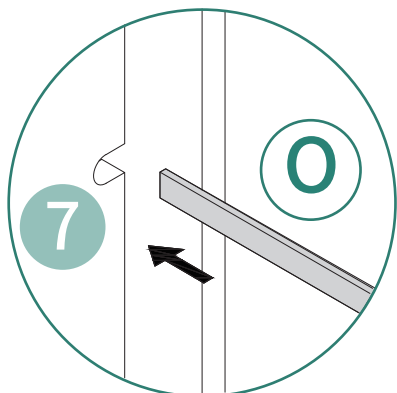

12



G1

Ⓞ1pc



G2

Ⓞ16pcs

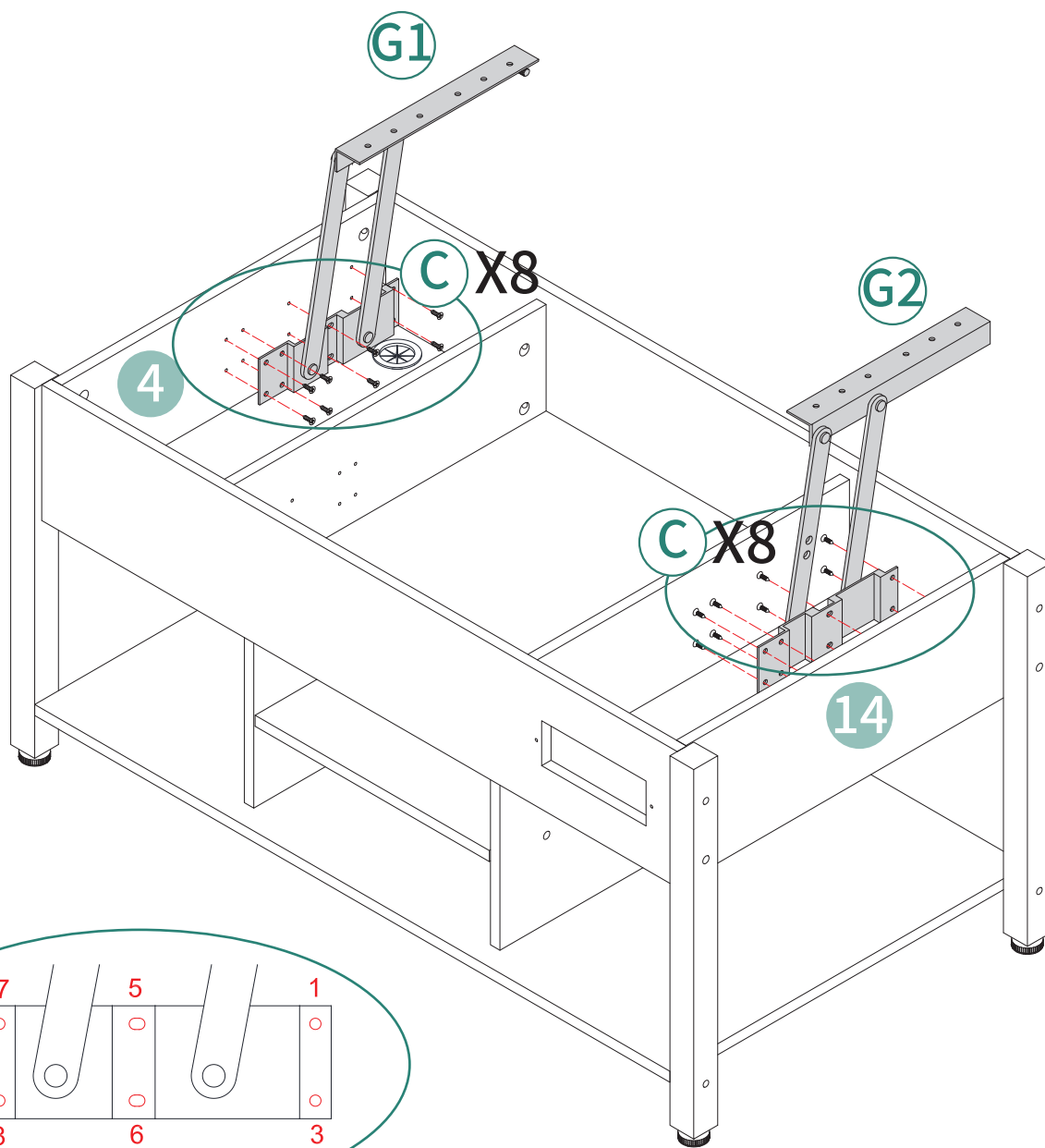

Install in sequence.
In Reihenfolge installieren.
Installer dans l'ordre.
Installare in sequenza.
Instalar en secuencia.

13

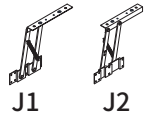

J1 J2



ⓐ 1pc

ⓐ 16pcs

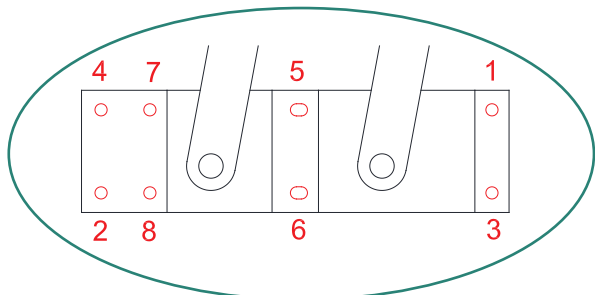
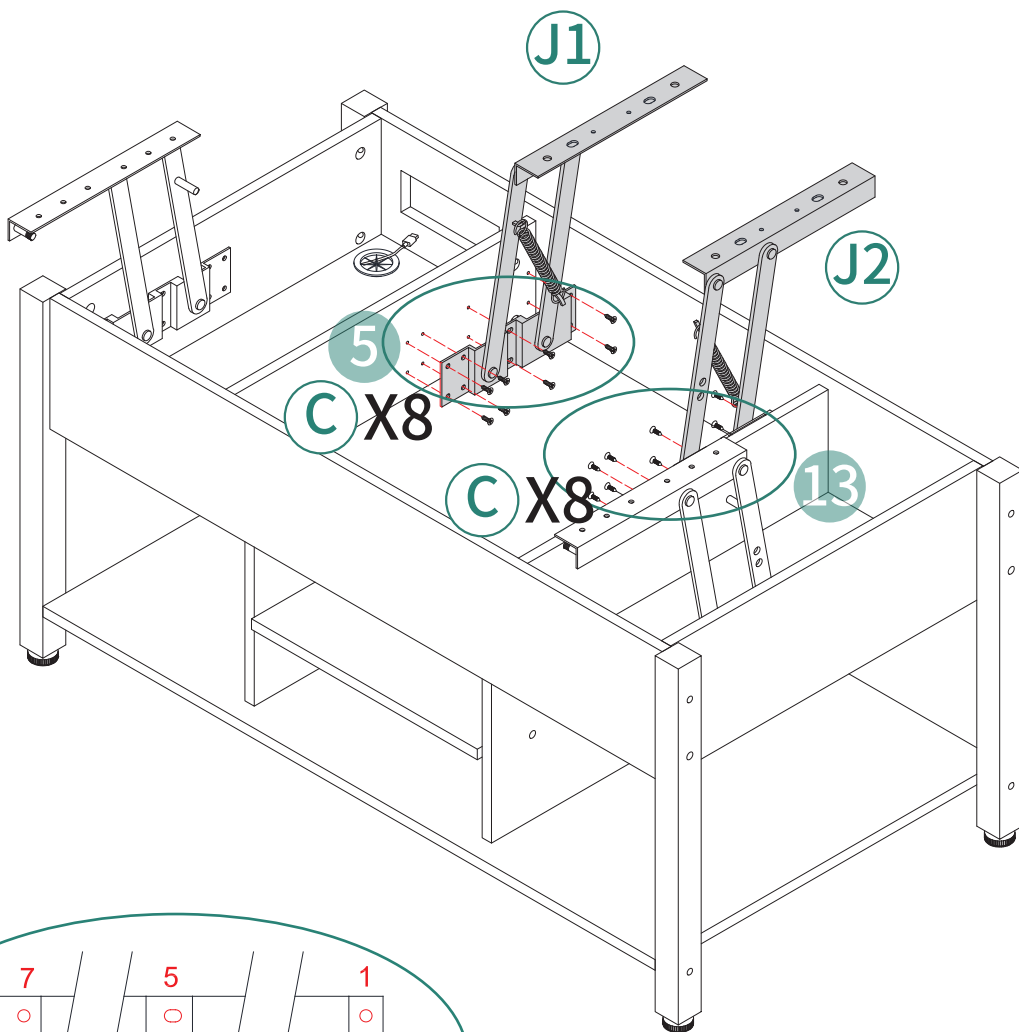

Install in sequence.
In Reihenfolge installieren.
Installer dans l'ordre.
Installare in sequenza.
Instalar en secuencia.

14



F4pcs

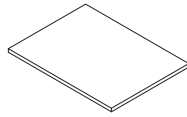

31pc

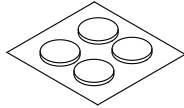

Q1pc

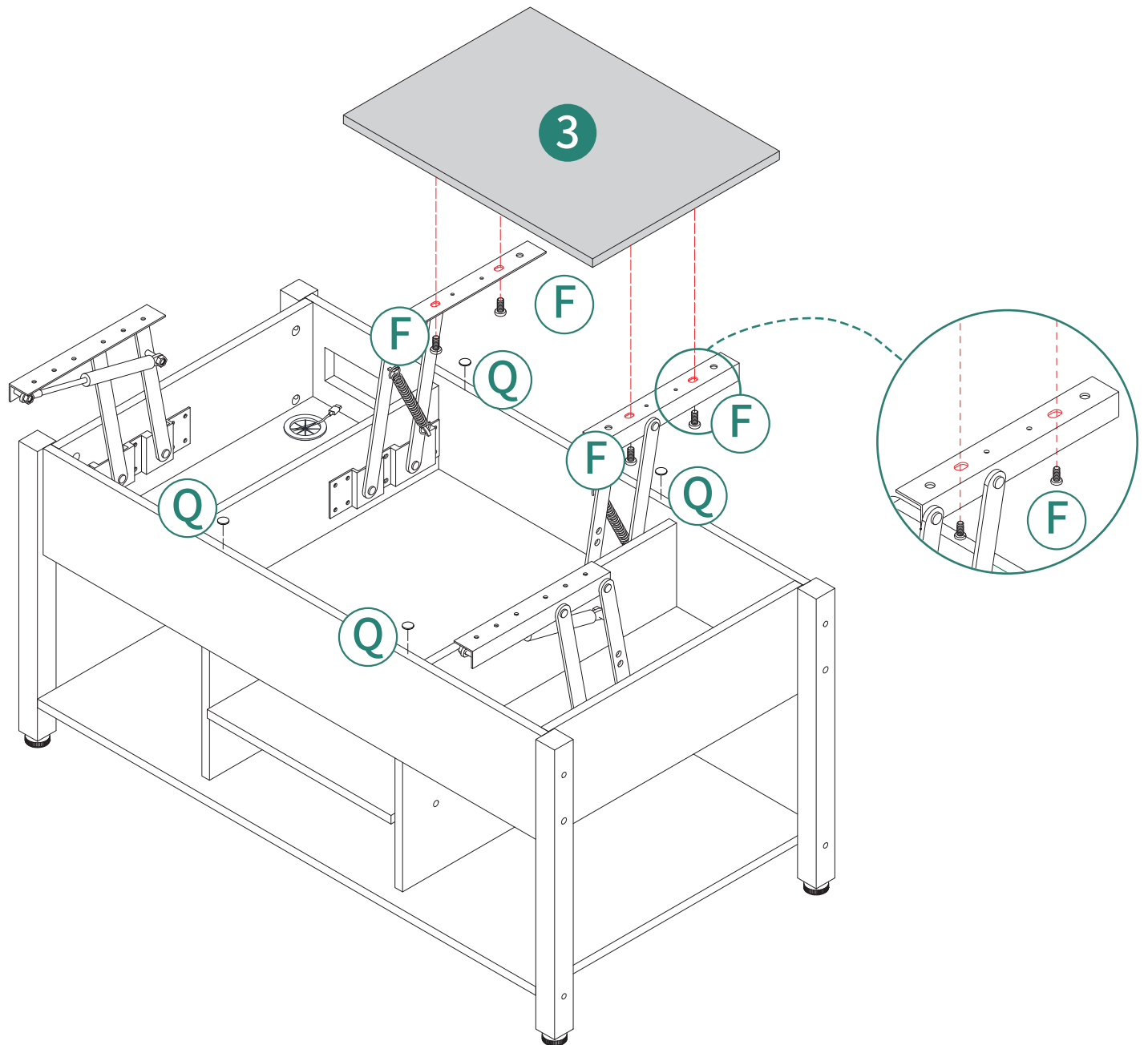

15

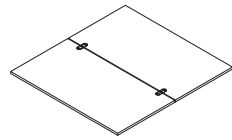

① 1pc



③ 12pcs



Please note the screw hole spacing in part 1 to avoid installation issues.

Bitte beachten Sie den Schraubenlochabstand in Teil 1, um Installationsprobleme zu vermeiden.

Veuillez noter l'espacement des trous de vis dans la pièce 1 pour éviter les problèmes d'installation.

Si prega di notare lo spaziamento dei fori per viti nella parte 1 per evitare problemi di installazione.

Por favor, tenga en cuenta el espaciado de los agujeros de tornillo en la pieza 1 para evitar problemas de instalación.

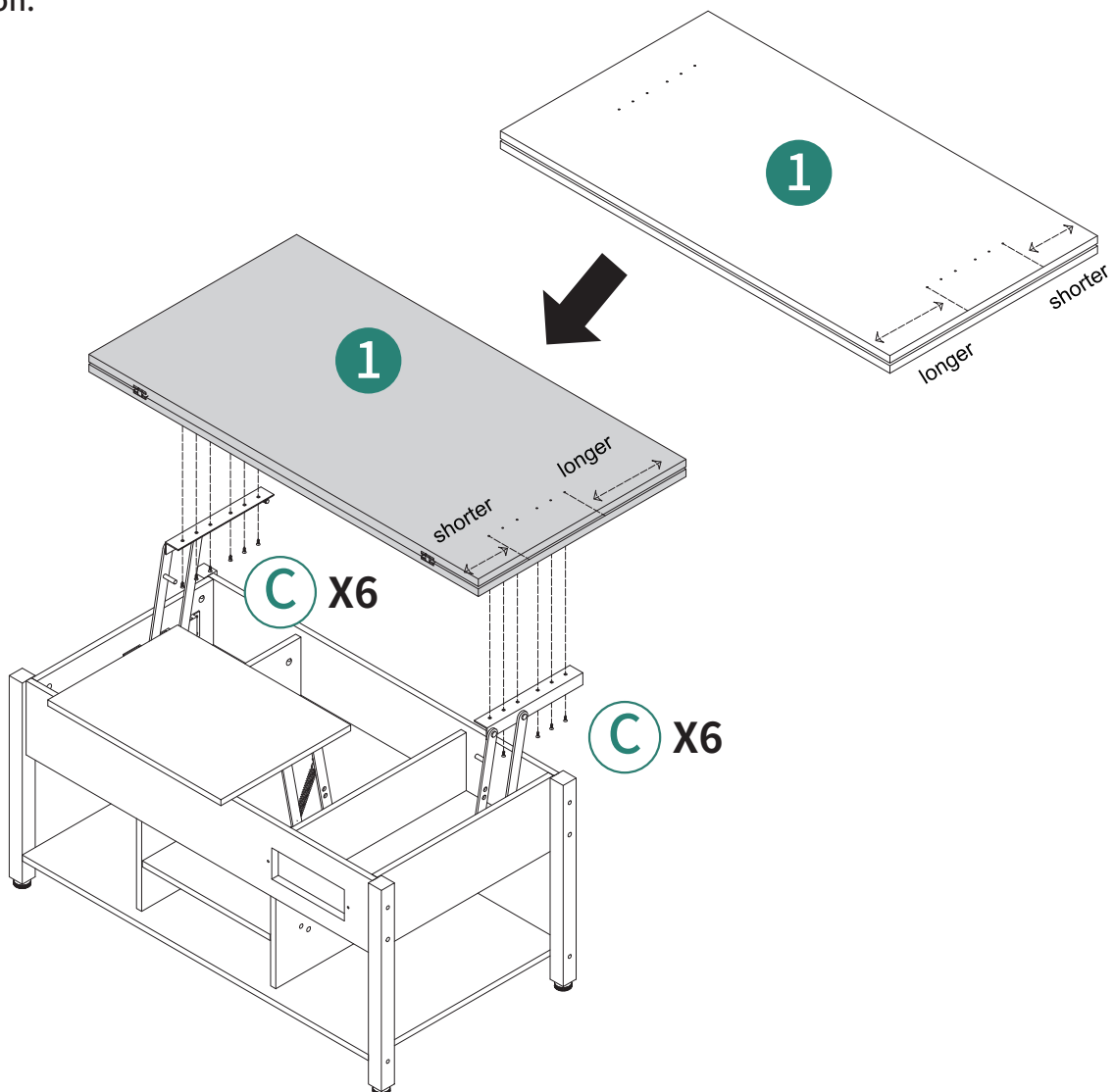

16

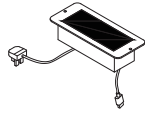

(N) 1pc



(C) 2pcs

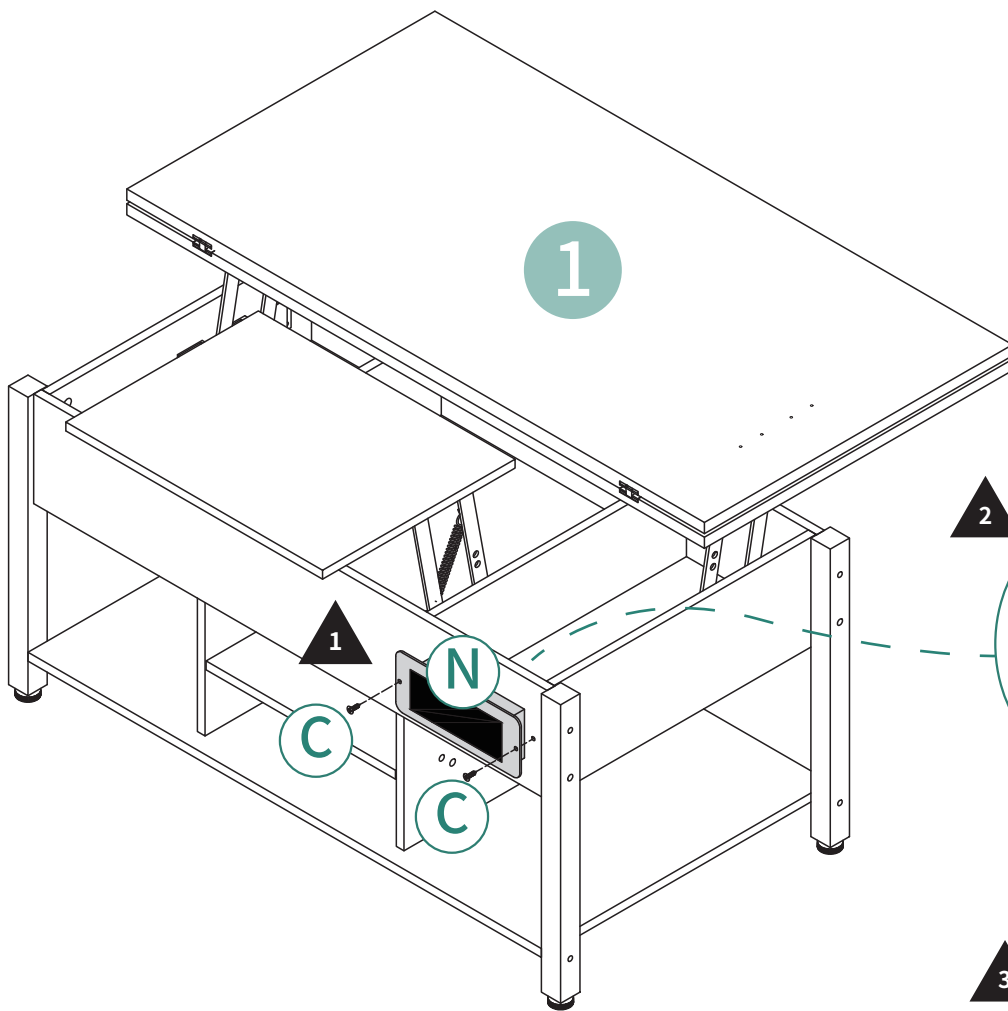

2

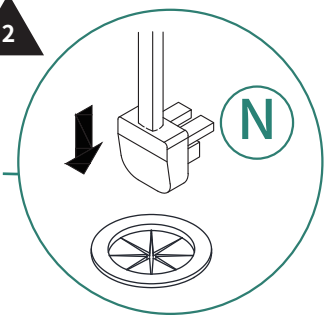

3

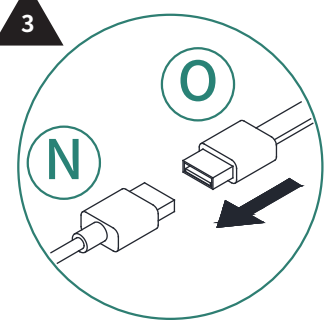

17

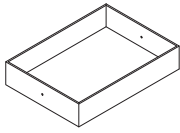

12 1pc



L 2pcs

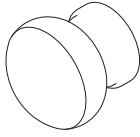

K 2pcs

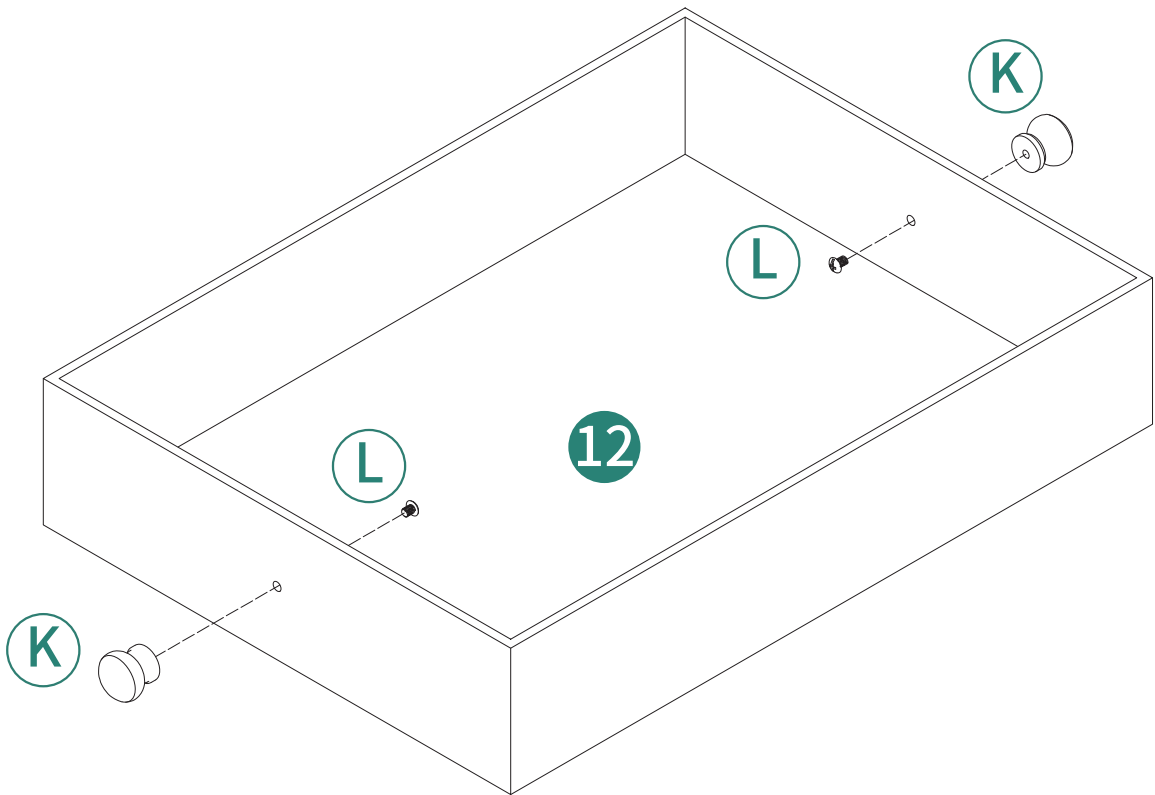

18

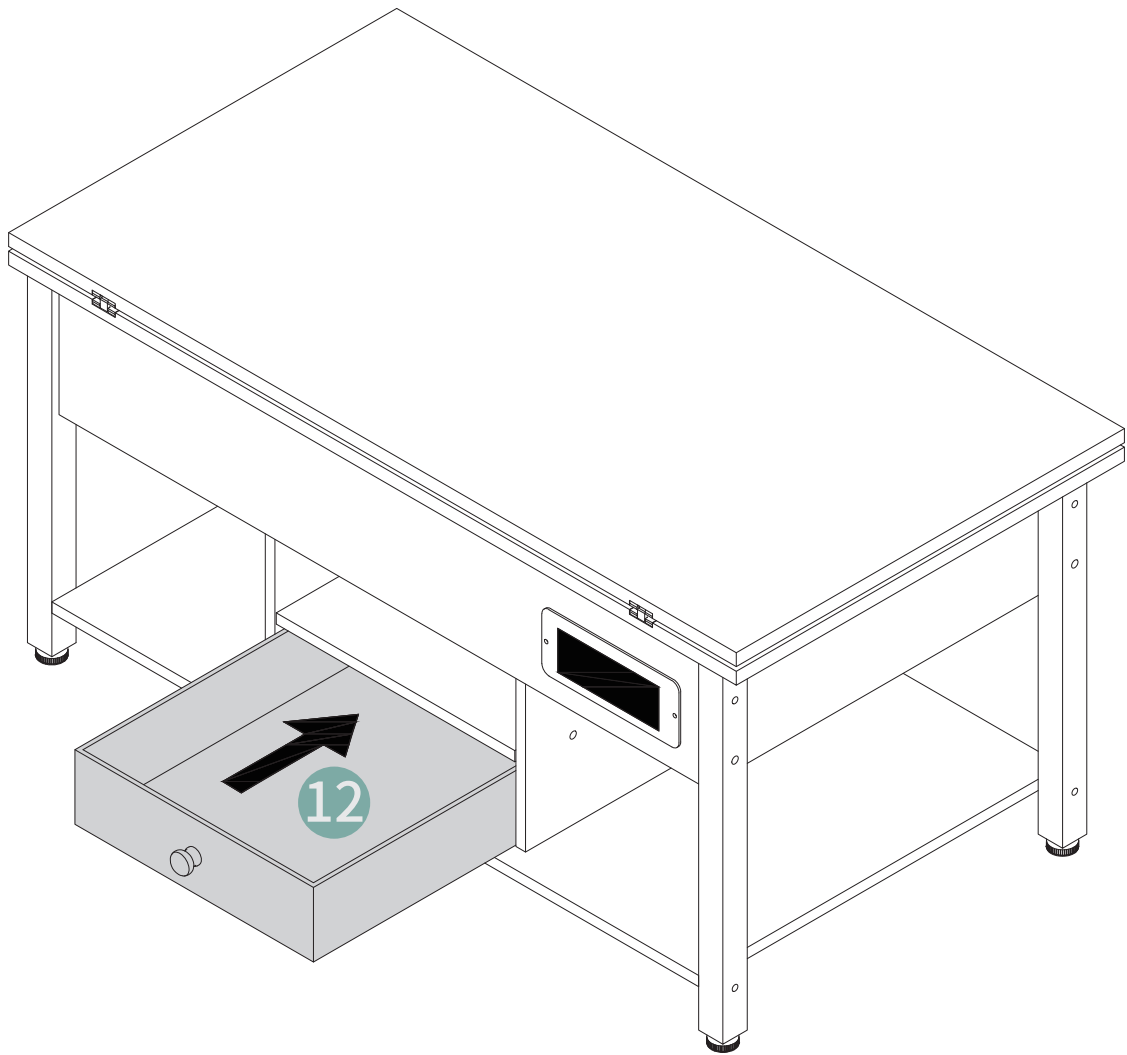

19

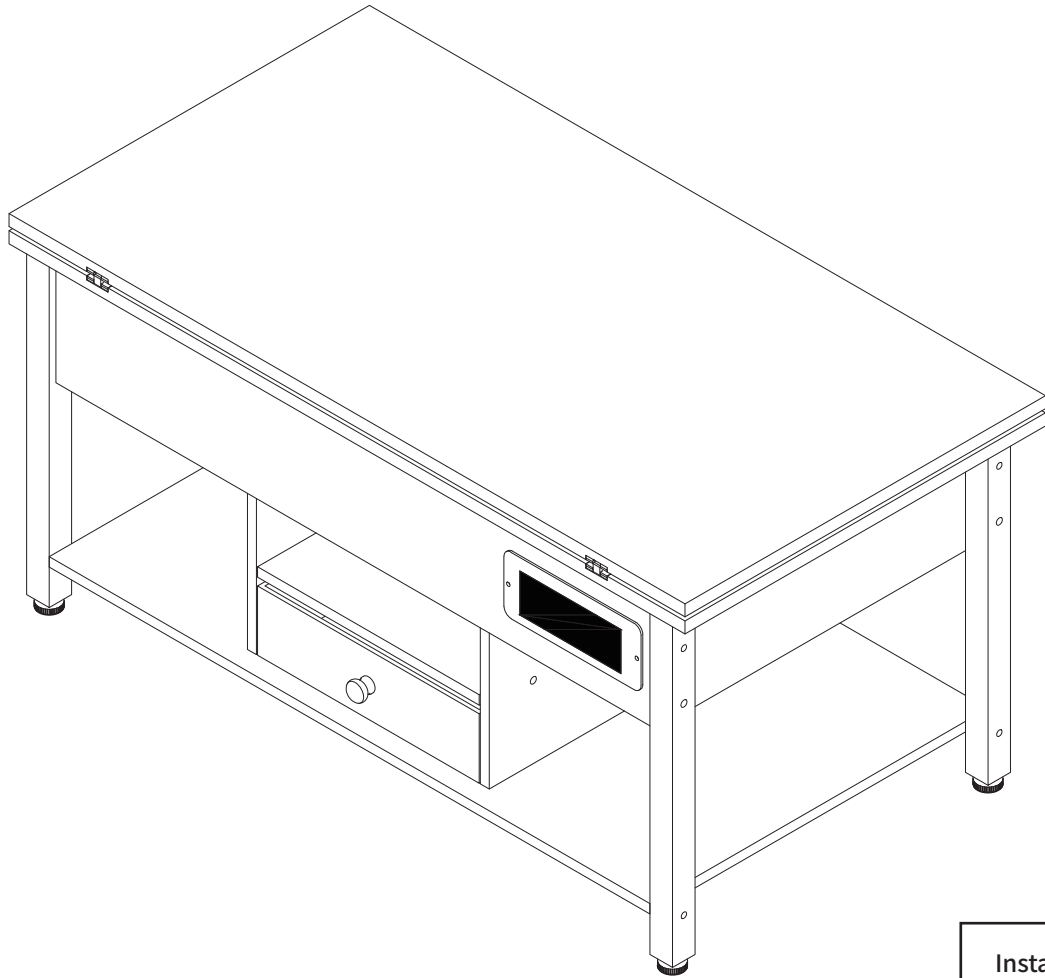

Installation Completed

Installation Abgeschlossen

Installation Complétée

Installazione Completata

Instalación Completada

HELP CENTER



Inquiry



Assembly issue



Missing parts

If you encounter any difficulties during assembly, please contact us.

Wenn Sie während der Montage auf Schwierigkeiten stoßen, kontaktieren Sie uns bitte.

Si vous rencontrez des difficultés lors du montage, veuillez nous contacter.

Se incontri difficoltà durante il montaggio, ti preghiamo di contattarci.

Si encuentras alguna dificultad durante el ensamblaje, por favor contáctanos.

DISCLAIMER

Manufacturer and seller expressly disclaim any and all liability for personal injury, property damage or loss, whether direct, indirect, or incidental, resulting from the incorrect attachment, improper use, inadequate maintenance, unapproved modification, or neglect of this product.

Der Hersteller und Verkäufer lehnen ausdrücklich jegliche Haftung für Personenschäden, Sachschäden oder Verluste ab, egal ob direkt, indirekt oder zufällig, die durch falsche Anbringung, unsachgemäßen Gebrauch, unzureichende Wartung, nicht genehmigte Änderungen oder Vernachlässigung dieses Produkts entstehen.

El fabricante y vendedor renuncian expresamente a toda responsabilidad por lesiones personales, daños materiales o pérdidas, ya sean directos, indirectos o incidentales, derivados de la incorrecta colocación, uso inadecuado, mantenimiento insuficiente, modificación no aprobada o negligencia de este producto.

Il produttore e il venditore declinano espressamente ogni responsabilità per lesioni personali, danni materiali o perdite, dirette, indirette o incidentali, derivanti dall'errato fissaggio, uso improprio, manutenzione inadeguata, modifica non autorizzata o negligenza di questo prodotto.

Le fabricant et le vendeur déclinent expressément toute responsabilité en cas de blessures corporelles, de dommages matériels ou de pertes, qu'ils soient directs, indirects ou accessoires, résultant de la fixation incorrecte, de l'utilisation inappropriée, de l'entretien insuffisant, de la modification non approuvée ou de la négligence de ce produit.