

# ASSEMBLY INSTRUCTION

## STORAGE BENCH W/ 2 SHELF

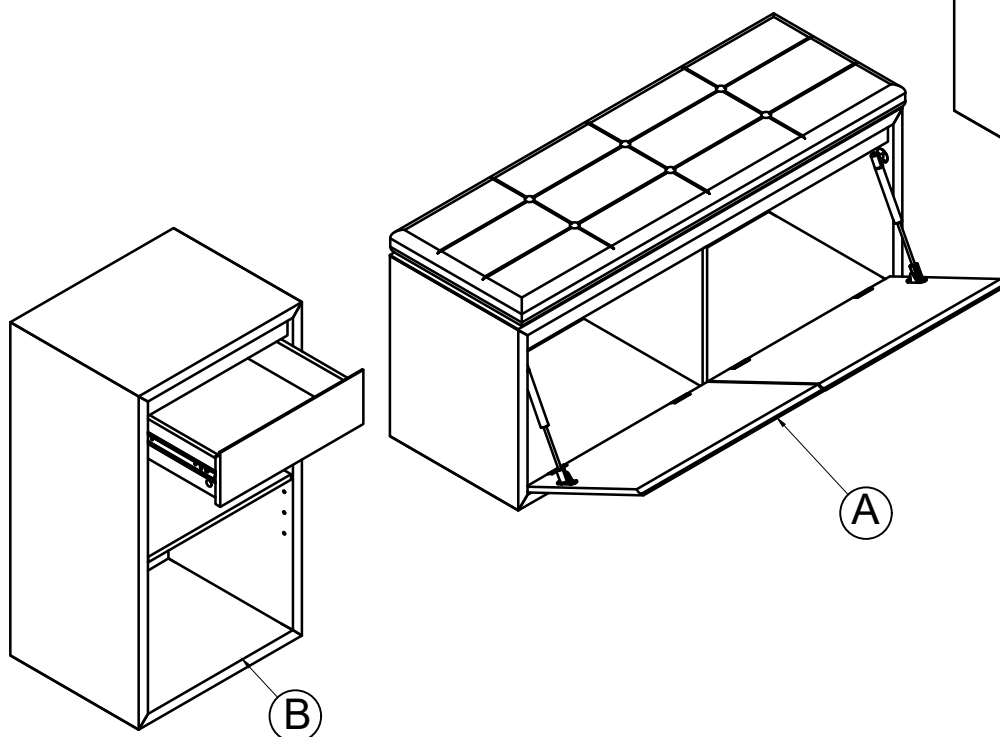

# ASSEMBLY INSTRUCTION

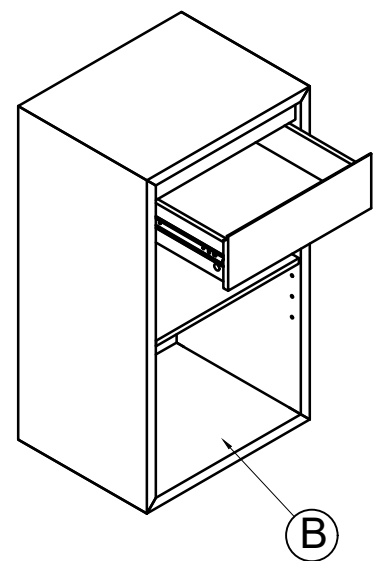
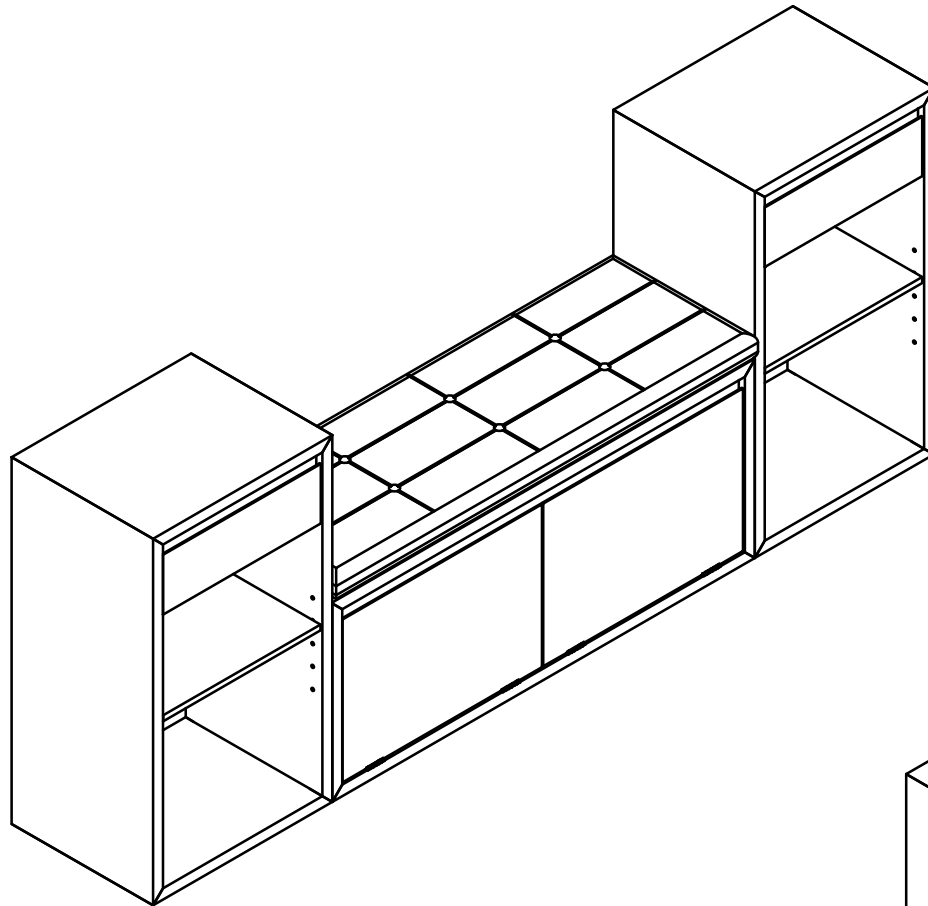

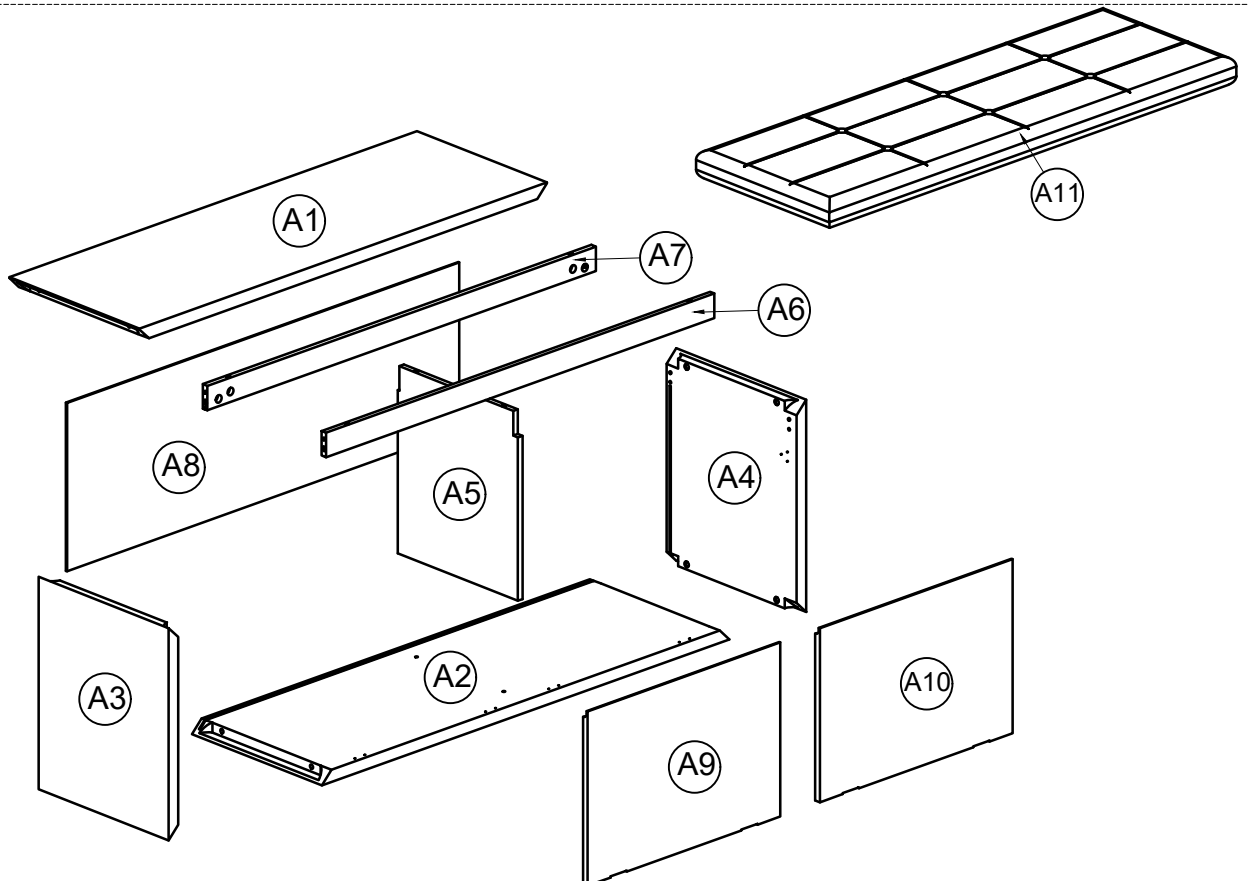
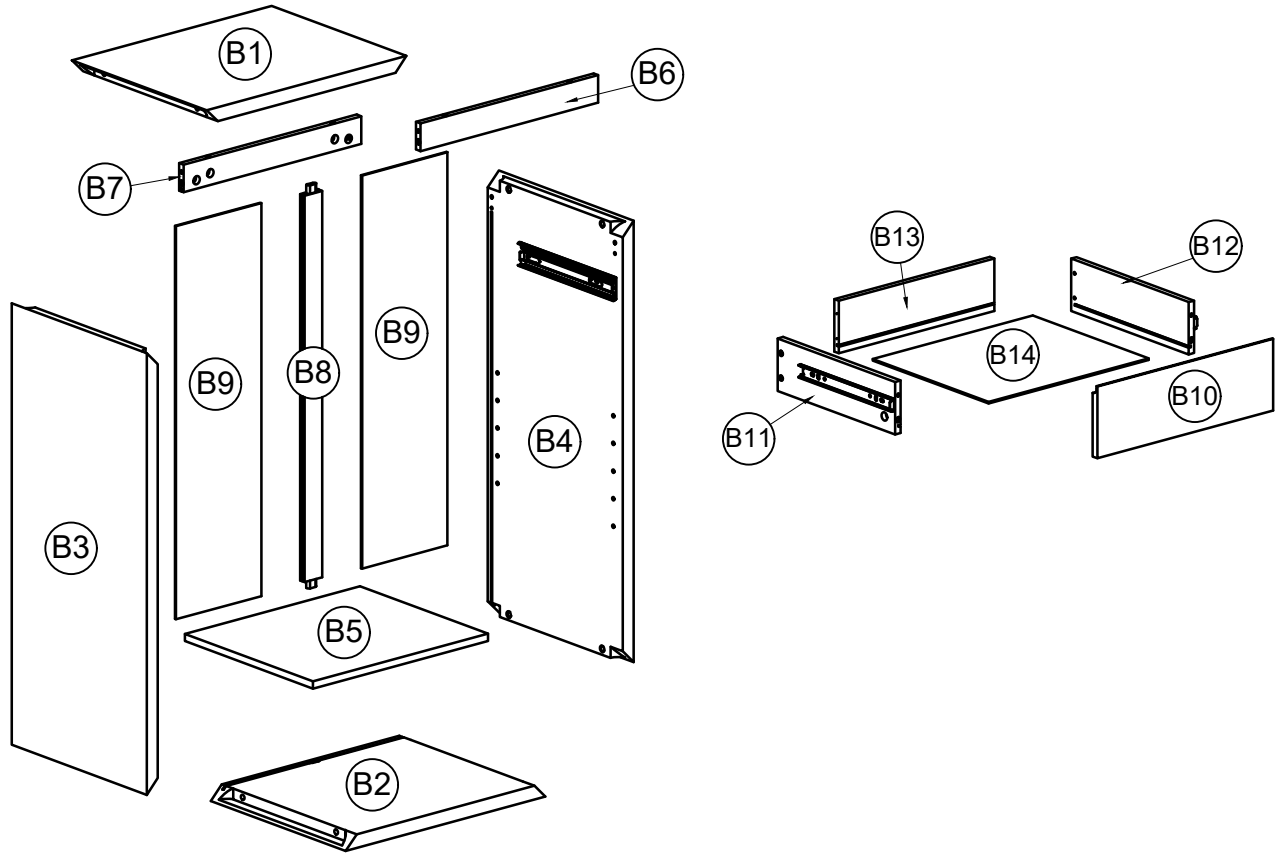
## STORAGE BENCH W/ 2 SHELF



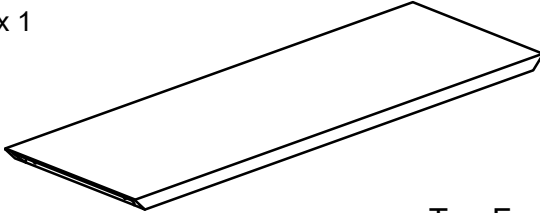
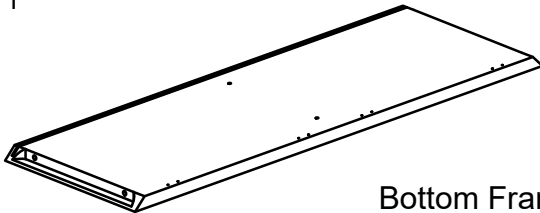
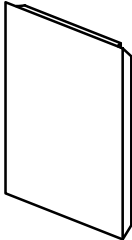
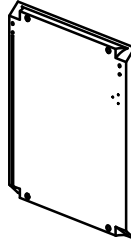
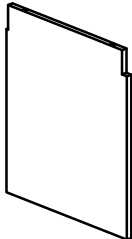
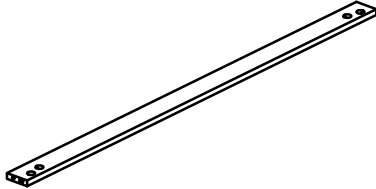
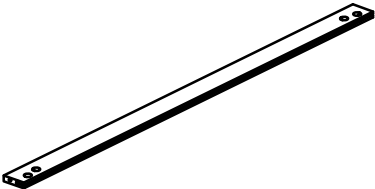
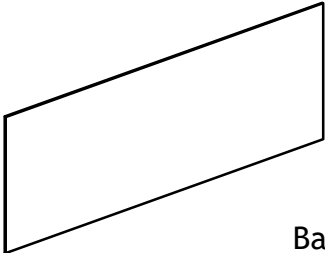
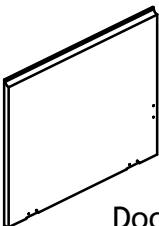
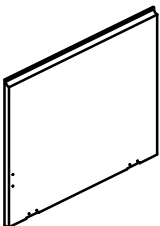
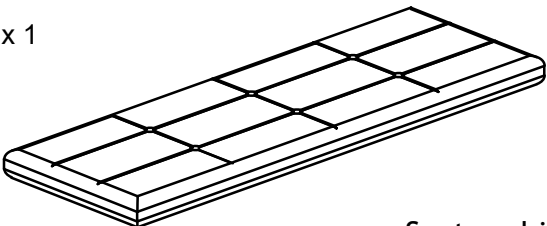

# PART LIST- A

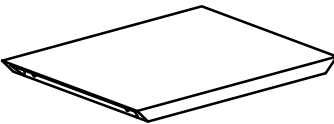
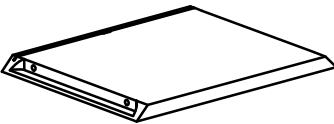
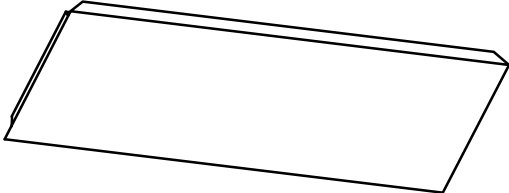
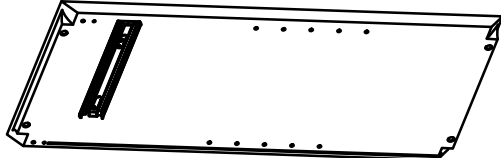
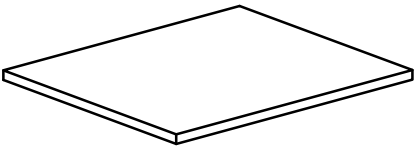
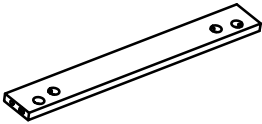
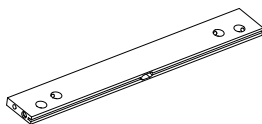
<p>(A1) x 1</p>  <p>Top Frame</p>	<p>(A2) x 1</p>  <p>Bottom Frame</p>
<p>(A3) x 1</p>  <p>Side Frame- Left</p>	<p>(A4) x 1</p>  <p>Side Frame- Right</p>
<p>(A5) x 1</p>  <p>Middle Partition</p>	<p>(A6) x 1</p>  <p>Connect Bar- Front</p>
<p>(A7) x 1</p>  <p>Connect Bar- Back</p>	<p>(A8) x 1</p>  <p>Back Panel</p>
<p>(A9) x 1</p>  <p>Door Panel- Left</p>	<p>(A10) x 1</p>  <p>Door Panel- Right</p>
<p>(A11) x 1</p>  <p>Seat cushion</p>	

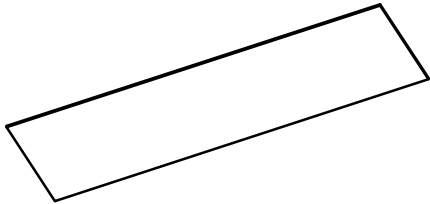
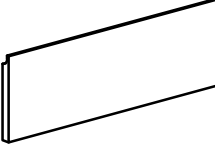
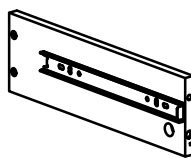
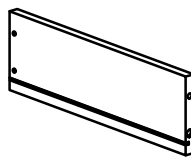
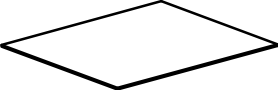
# PART LIST- B

<p>(B1) x 2</p>  <p>Top Frame</p>	<p>(B2) x 2</p>  <p>Bottom Frame</p>
<p>(B3) x 2</p>  <p>Side Frame- Left</p>	<p>(B4) x 2</p>  <p>Side Frame- Right</p>
<p>(B5) x 2</p>  <p>Shelf</p>	<p>(B6) x 2</p>  <p>Connect Bar- Front</p>
<p>(B7) x 2</p>  <p>Connect Bar- Back</p>	<p>(B8) x 2</p>  <p>Middle Vertical Bar- Back</p>
<p>(B9) x 4</p>  <p>Back Panel</p>	<p>(B10) x 2</p>  <p>Front Panel- Drawer</p>
<p>(B11) x 2</p>  <p>Left Side Panel- Drawer</p>	<p>(B12) x 2</p>  <p>Right Side Panel- Drawer</p>
<p>(B13) x 2</p>  <p>Back Panel- Drawer</p>	<p>(B14) x 2</p>  <p>Bottom Panel- Drawer</p>

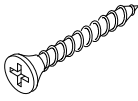
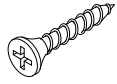
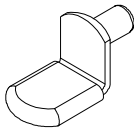
# HARDWARE LIST

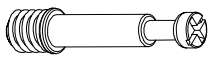
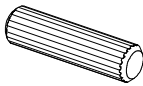
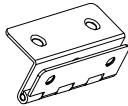
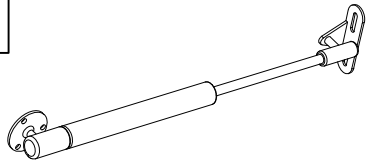
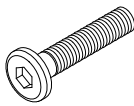
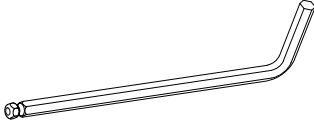
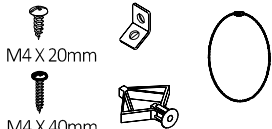
<p><b>A0</b></p>  <p>Flat Metal 4pcs</p>	<p><b>B0</b></p>  <p>M4x25mm Wood Screw 16pcs</p>	<p><b>C</b></p>  <p>M3.5x12mm Wood Screw 26pcs</p>
<p><b>D</b></p>  <p>Shelf Pin 8pcs</p>	<p><b>E</b></p>  <p>Ø15x9mm Cam Head 32pcs</p>	<p><b>F</b></p>  <p>Ø6x35mm Cam Bridge 32pcs</p>
<p><b>G</b></p>  <p>Ø6 x 30 mm Wood dowel 16pcs</p>	<p><b>H</b></p>  <p>Hinge 4pcs</p>	<p><b>I</b></p>  <p>Hydraulic Lifting 2pcs</p>
<p><b>J</b></p>  <p>M6 x 40 mm Bolt 24pcs</p>	<p><b>K</b></p>  <p>Allen key 1pcs</p>	<p><b>L</b></p>  <p>M4 X 20mm M4 X 40mm Anti-tip 2 set</p>

## ASSEMBLY TOOLS REQUIRED (NOT INCLUDED)

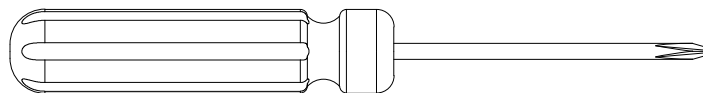

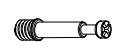
**F****6**

## STEP 1: Following below illustration

-Using hardware #F assembly into A1

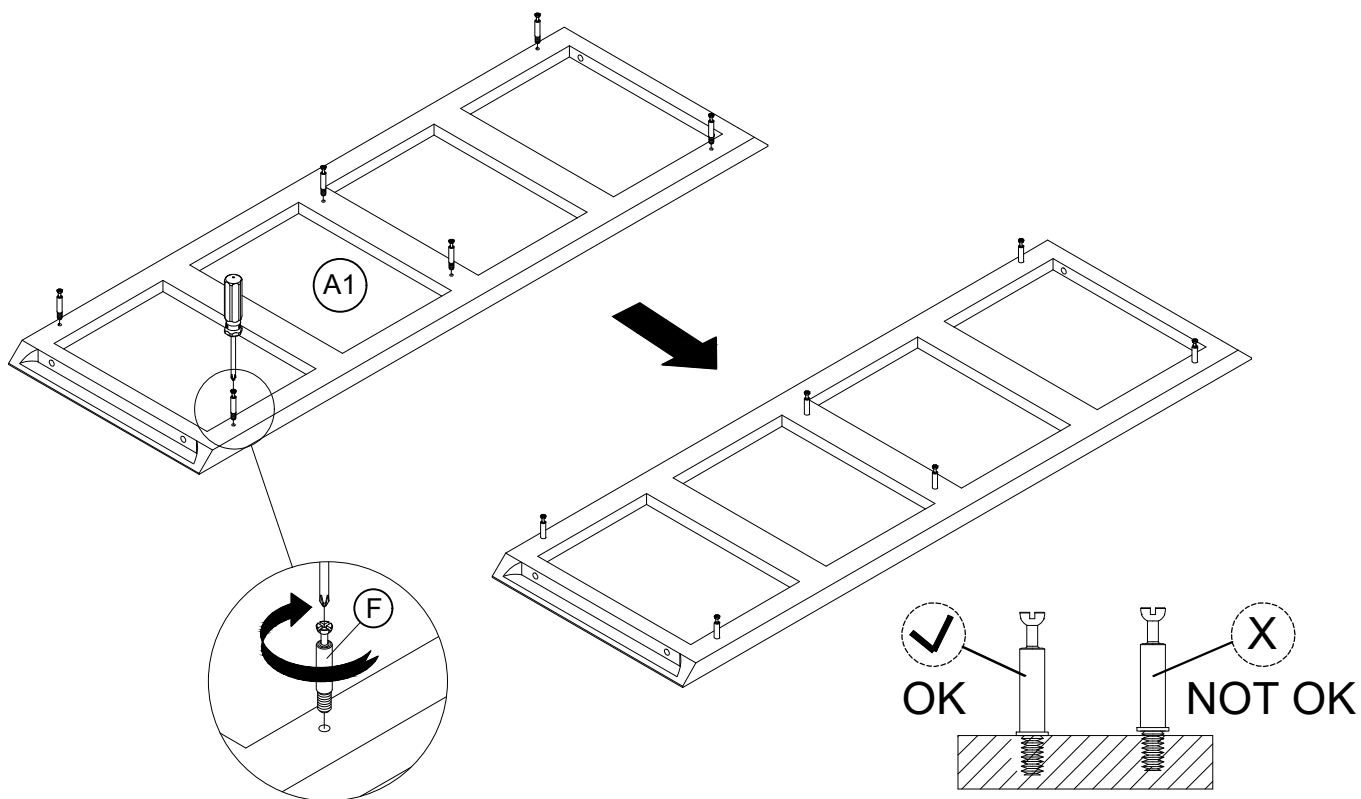

## STEP 2: Following below illustration

-Using hardware #E connect A6, A7 with A1

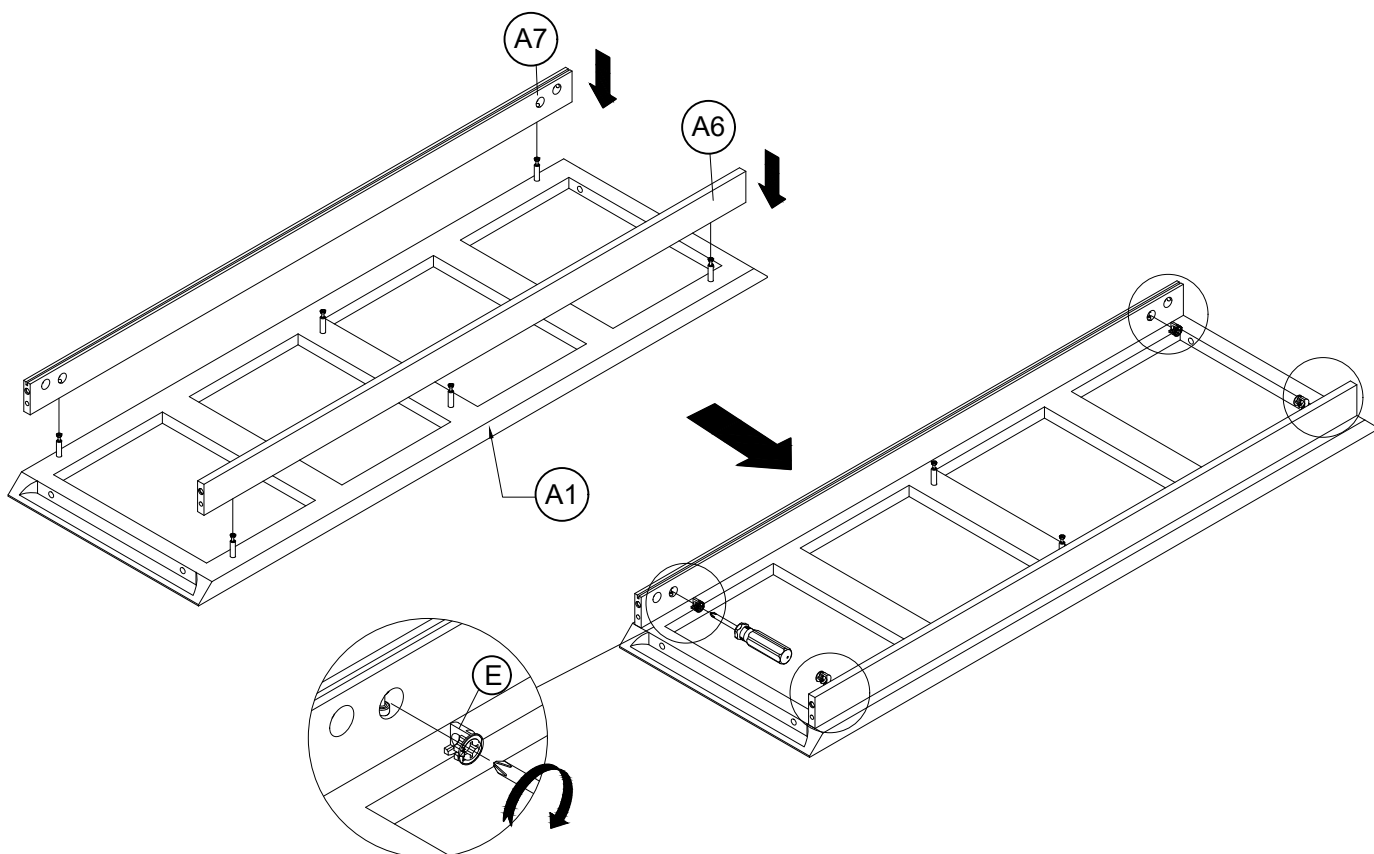
**E****4**

E



2

### STEP 3: Following below illustration

-Using hardware #E connect A5 with A1 assembly step 2

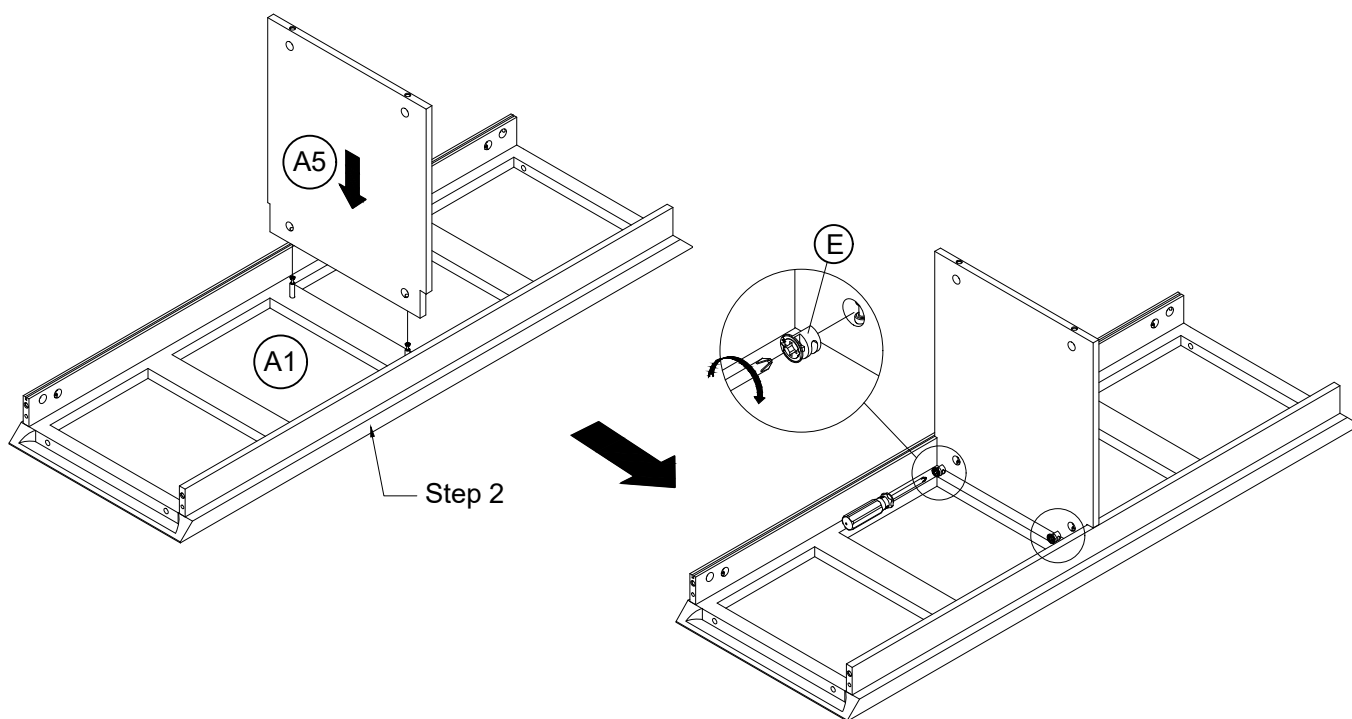

F



4



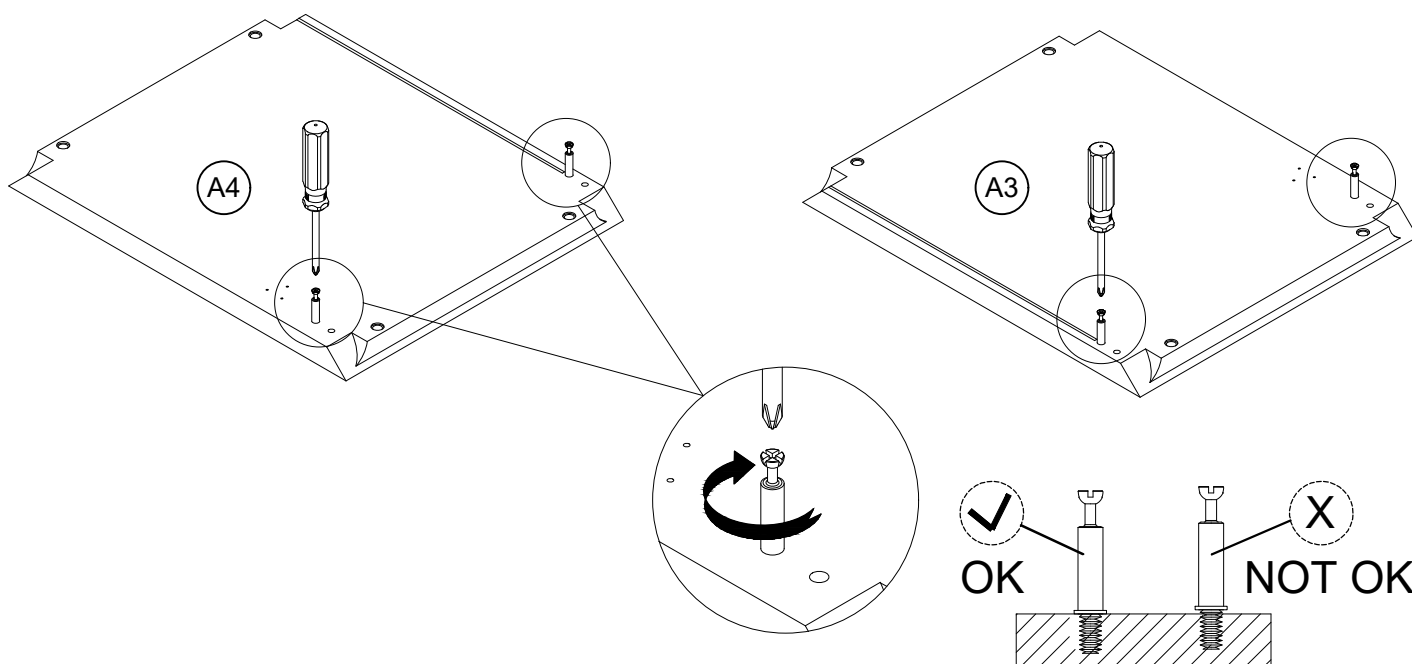

### STEP 4: Following below illustration

-Using hardware #F assembly into A3, A4



## STEP 5: Following below illustration



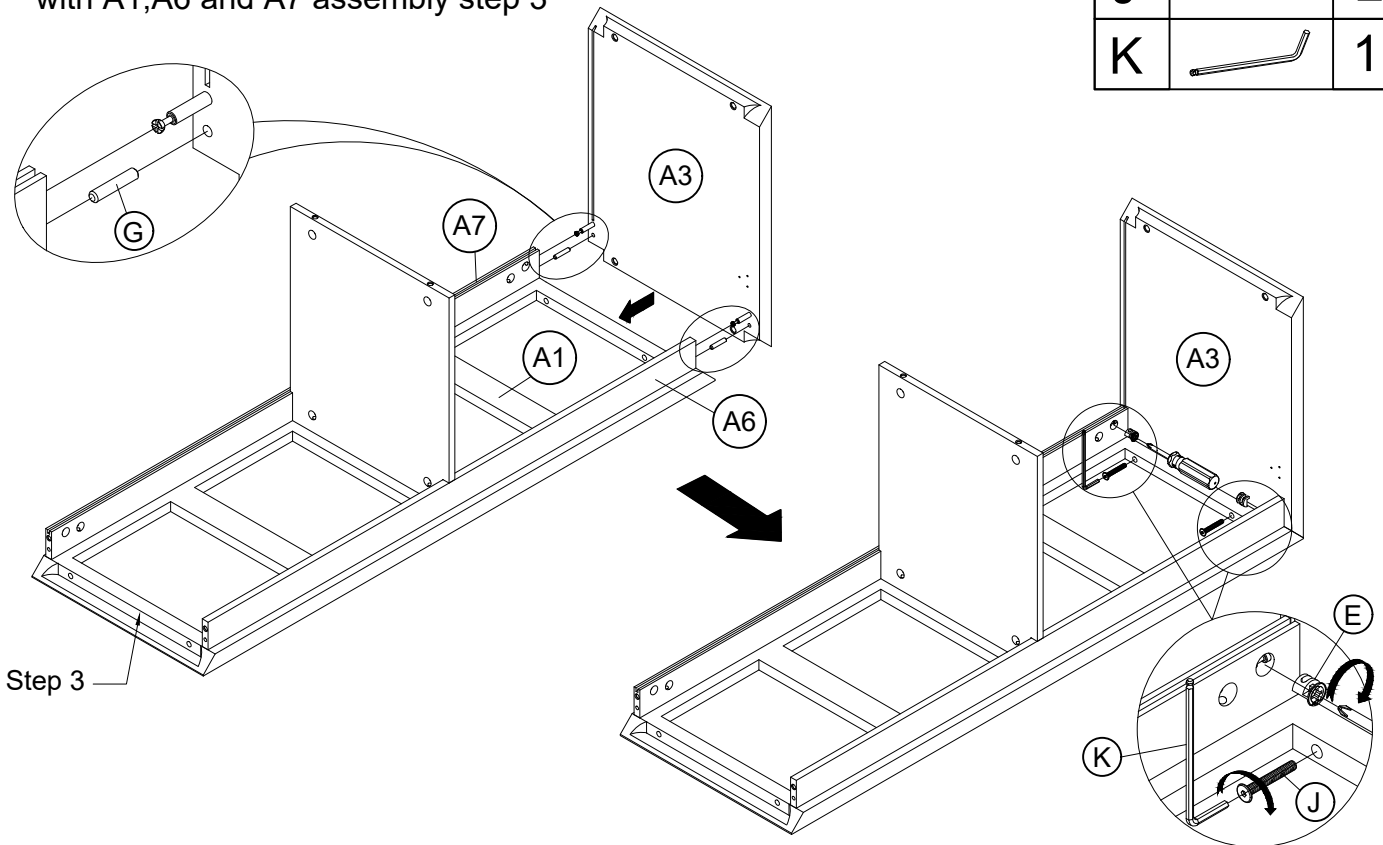

-Using hardware #E, #G and #J connect A3 with A1,A6 and A7 assembly step 3

E		2
G		2
J		2
K		1



## STEP 6: Following below illustration

-Using hardware #E, #G and #J connect A4 with A1,A6 and A7 assembly step 5

E		2
G		2
J		2
K		1

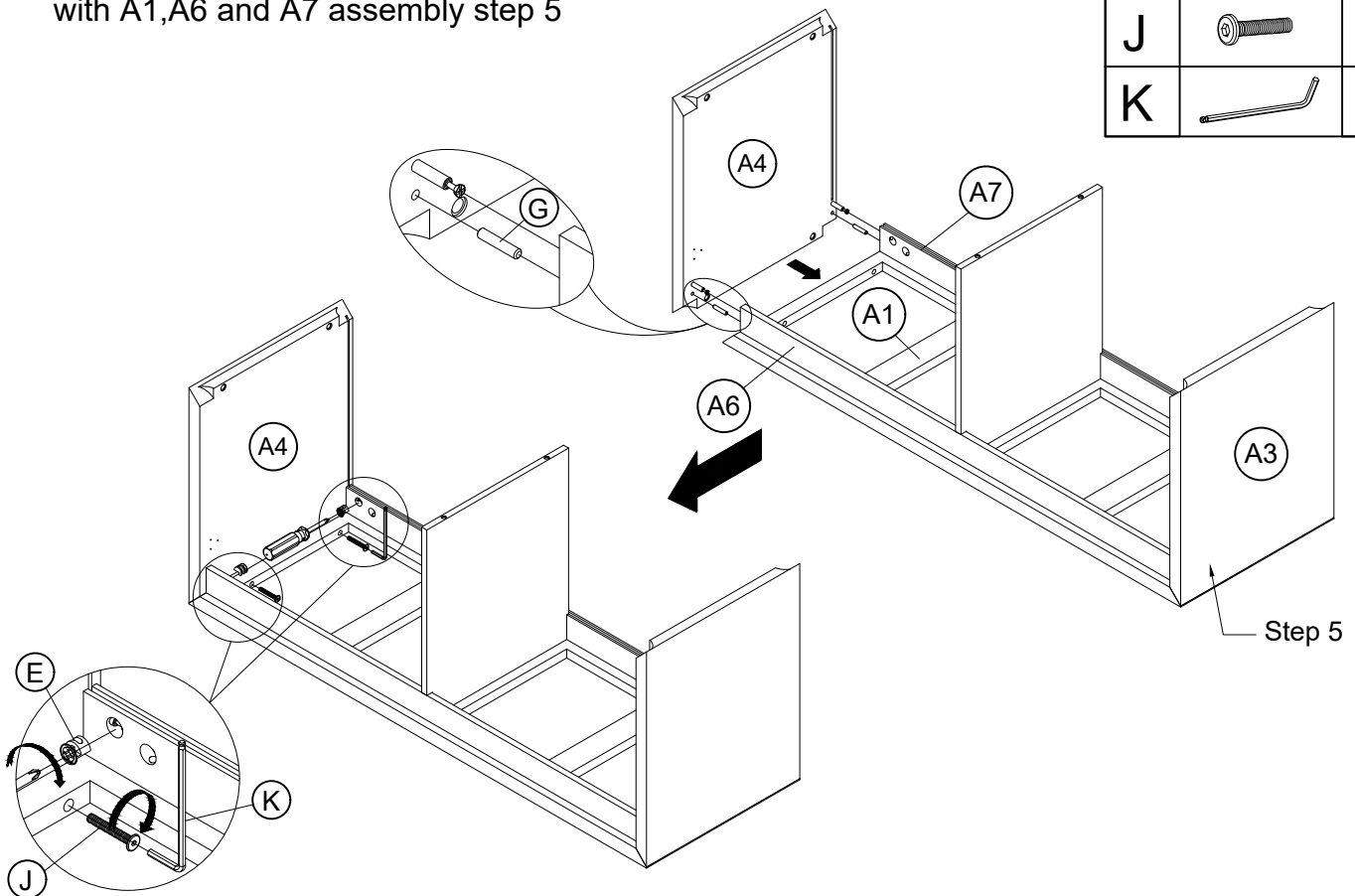

F

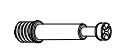

2

## STEP 7:

Following below illustration

-Using hardware #F assembly into A2

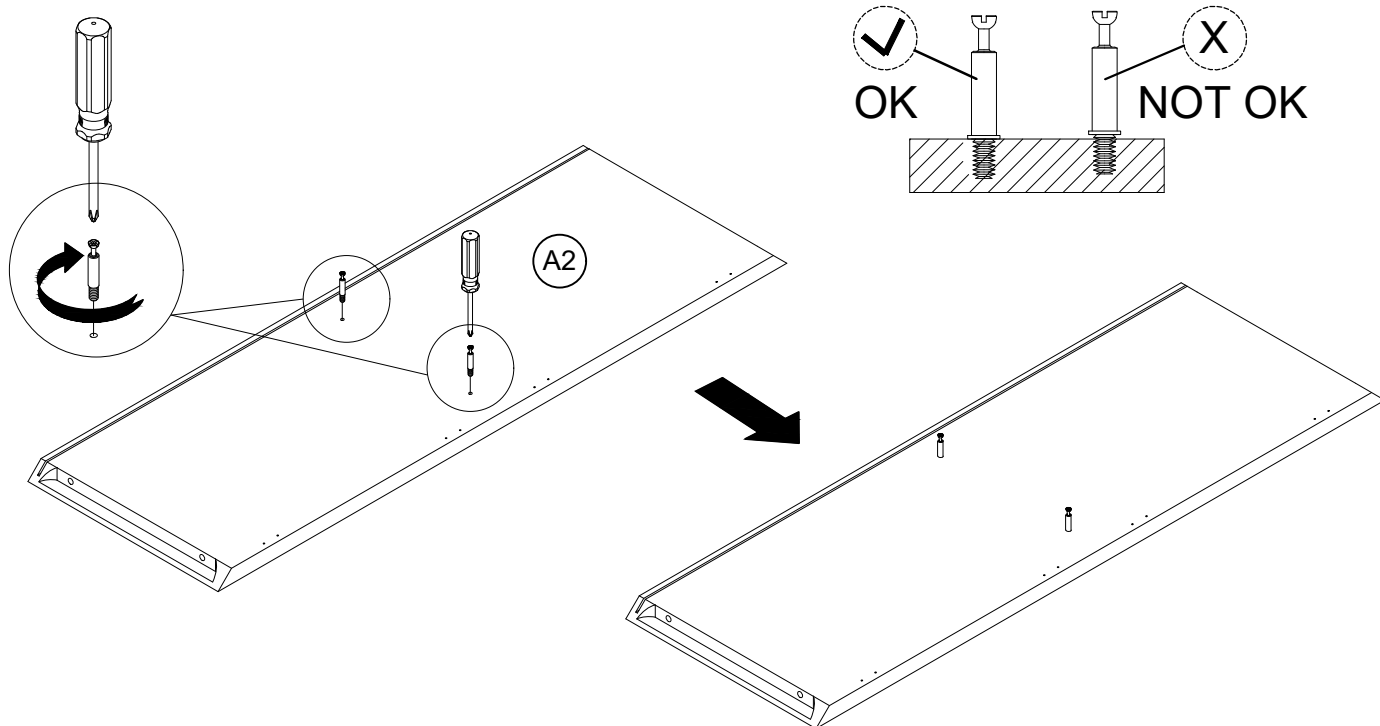

## STEP 8:

Following below illustration

-Using hardware #E, #J connect A2,A8 with A3,A4 and A5 assembly step 6

E



2

J

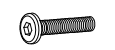

4



K

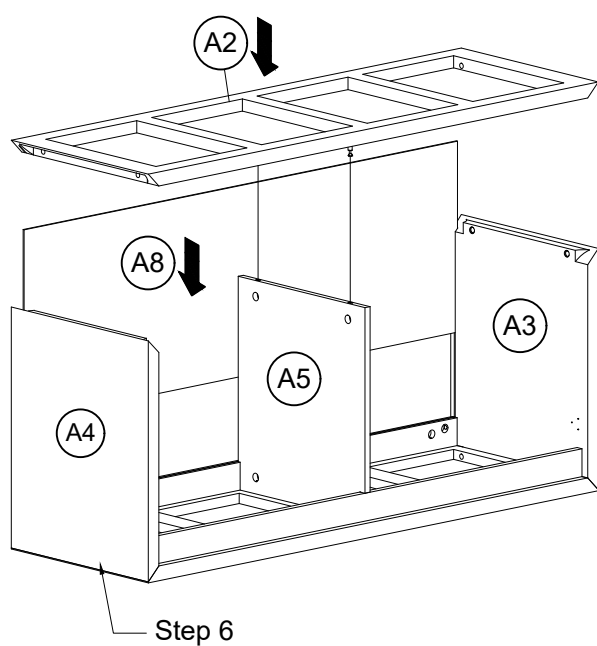

1



Step 6

C		8
H		4

**STEP 9:** Following below illustration  
 -Using hardware #C,#H assembly into A2

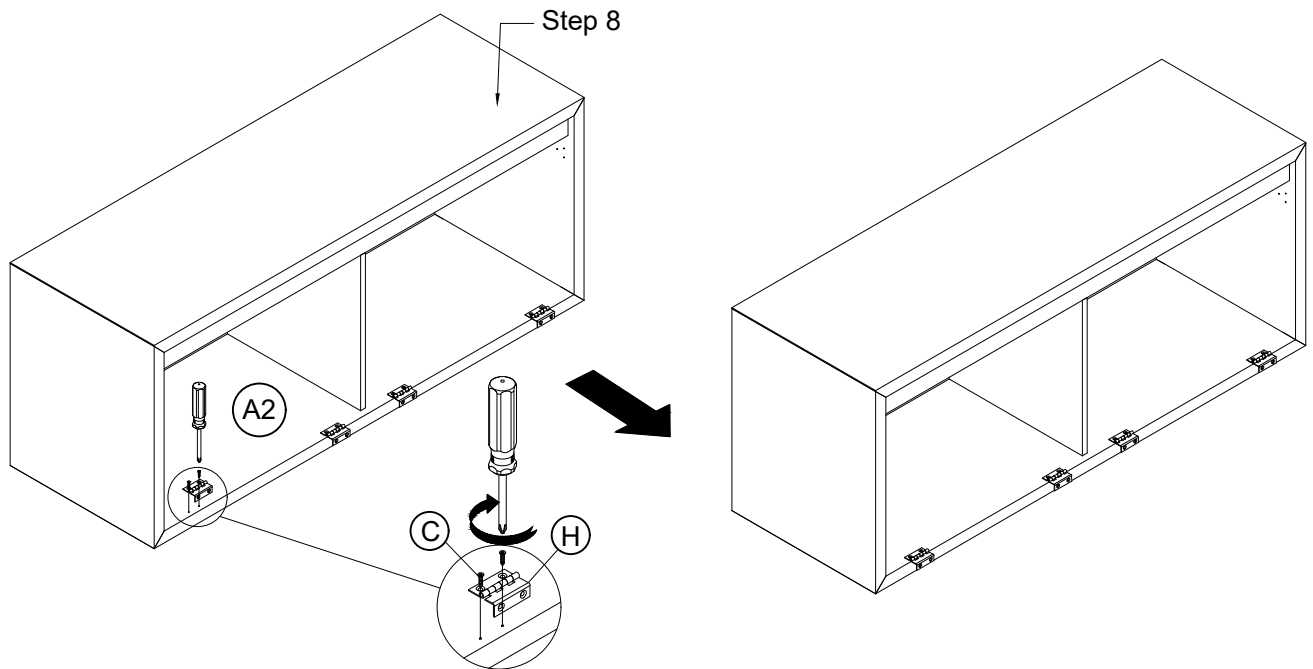

C		8
---	---	---

**STEP 10:** Following below illustration  
 -Using hardware #C connect A9, A10 with A2 assembly step 9

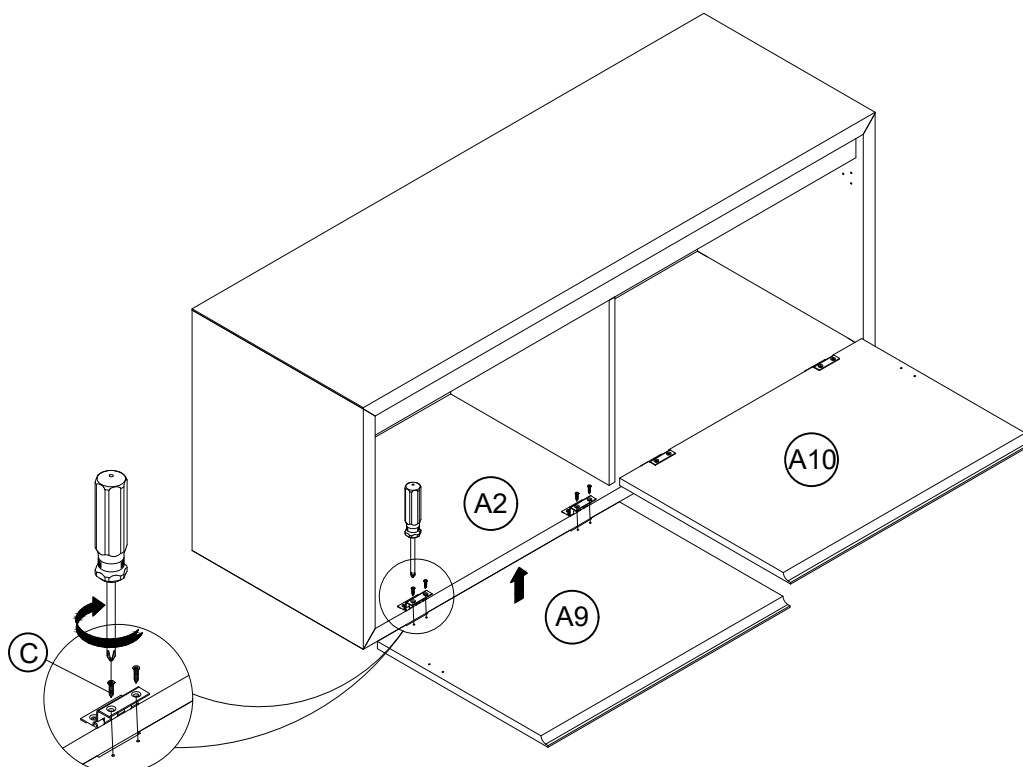

## STEP 11: Following below illustration

-Using hardware #C,#I assembly into A3, A4

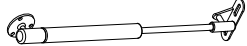
C		6
I		2

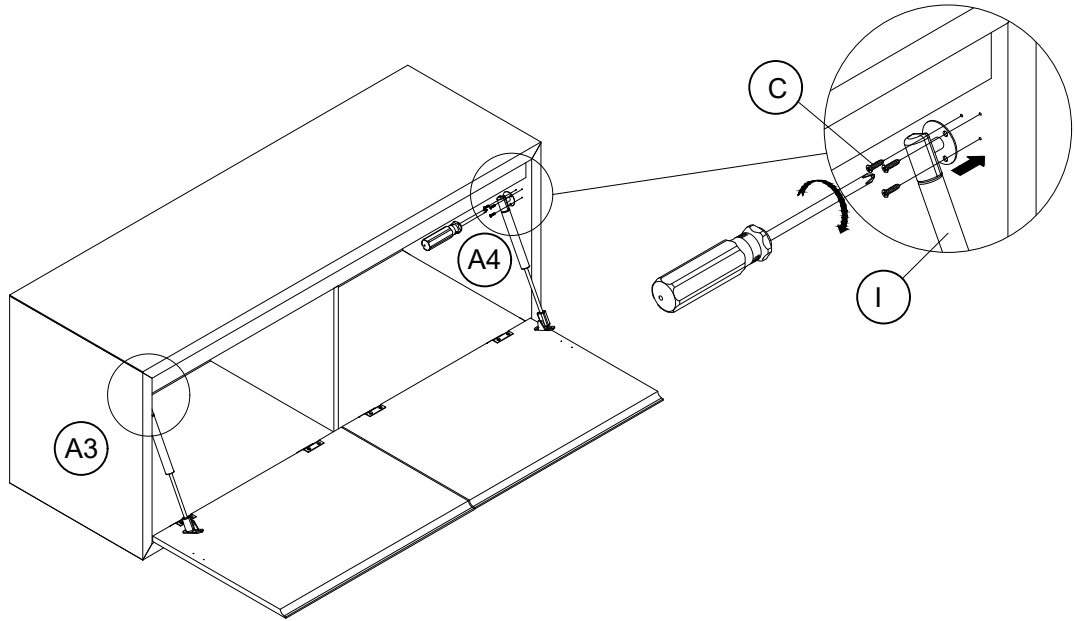

## STEP 12: Following below illustration

-Using hardware #C,#I connect A9, A10 with A3, A4 assembly step 11

C		4
---	---	---

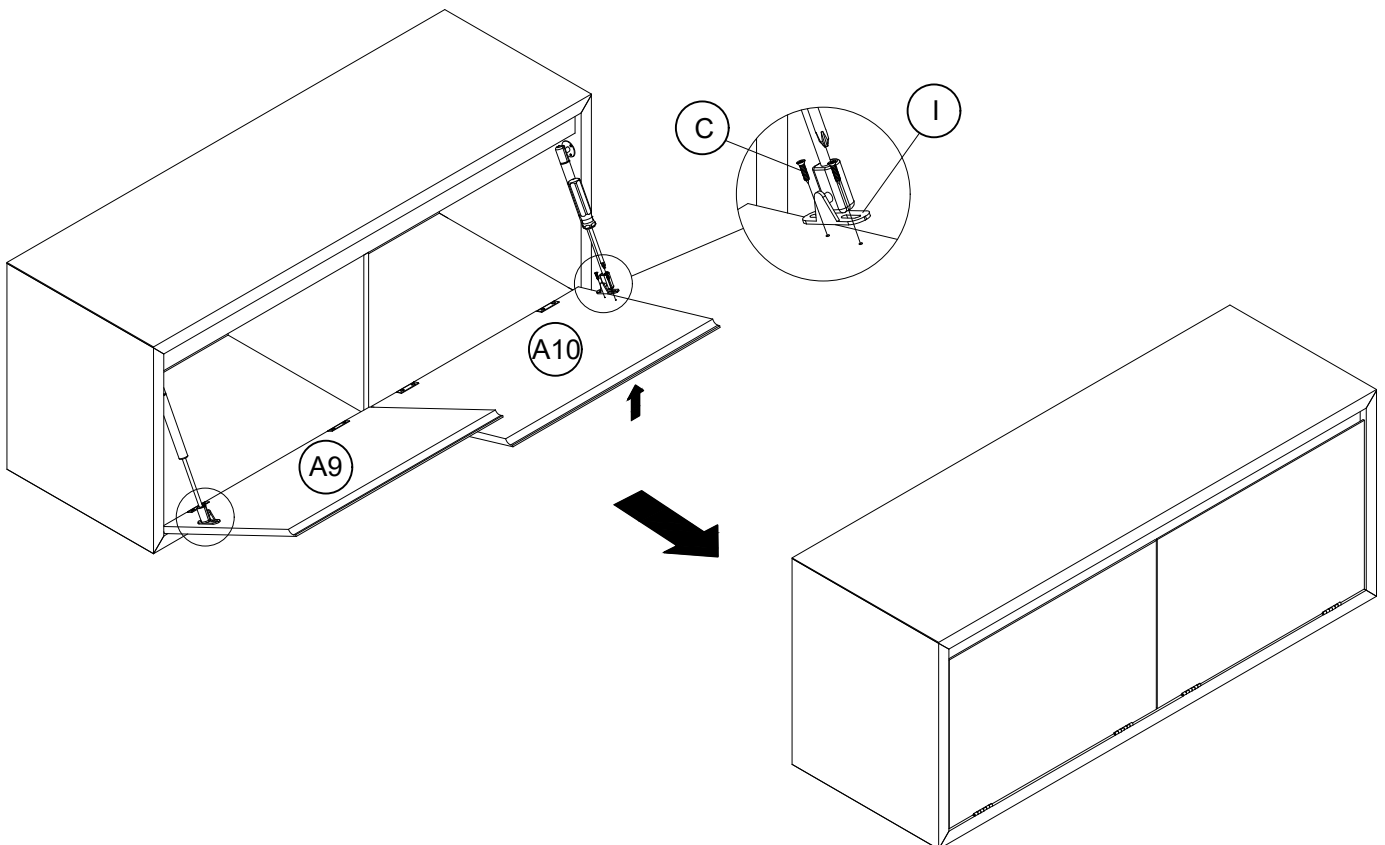

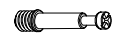
**F****8**

### STEP 13: Following below illustration

-Using hardware #F assembly into B1

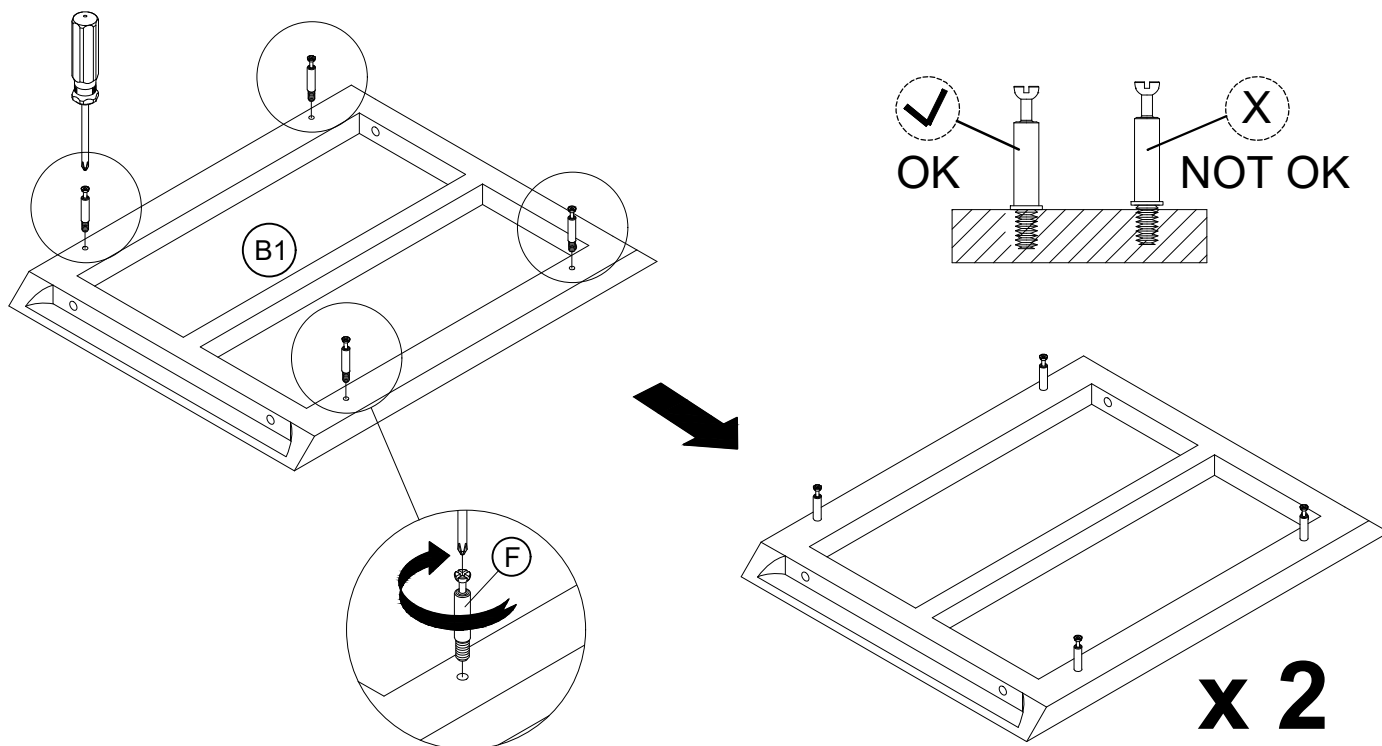
**E****8**

### STEP 14: Following below illustration

-Using hardware #E connect B6, B7 with B1

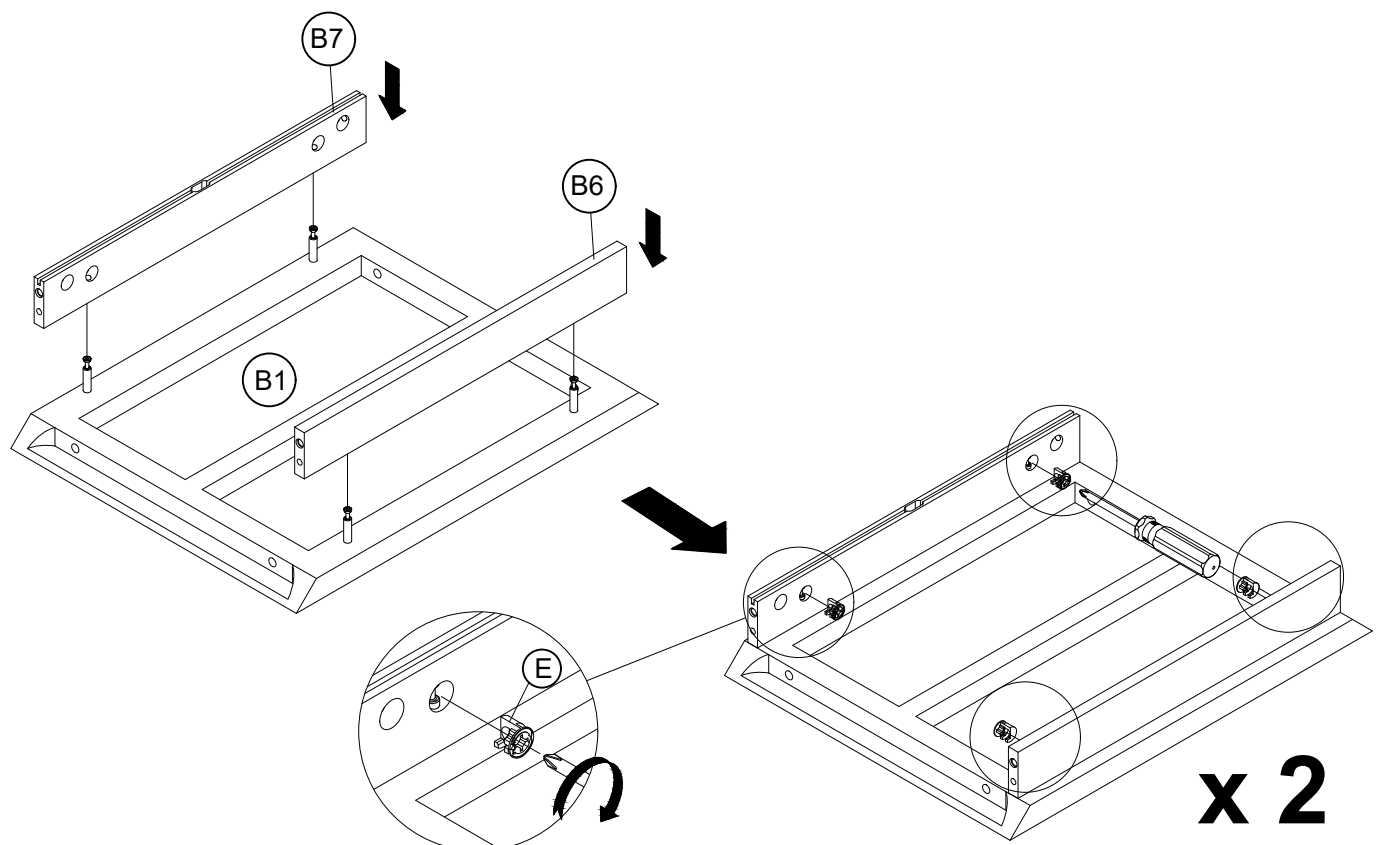

F

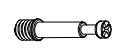

8

## STEP 15: Following below illustration

-Using hardware #F assembly into B3, B4

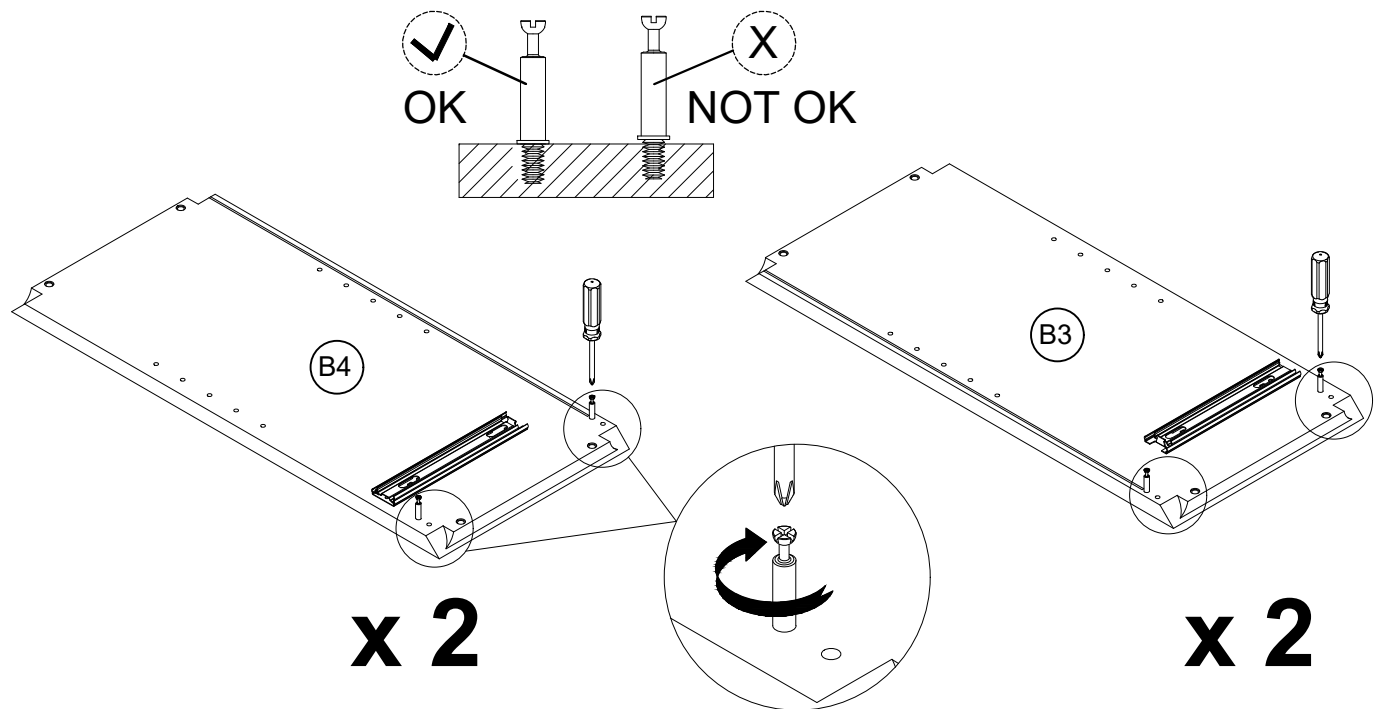



## STEP 16: Following below illustration

-Using hardware #E, #G and #J connect B3, B4 with B1, B6 and B7 assembly step 14

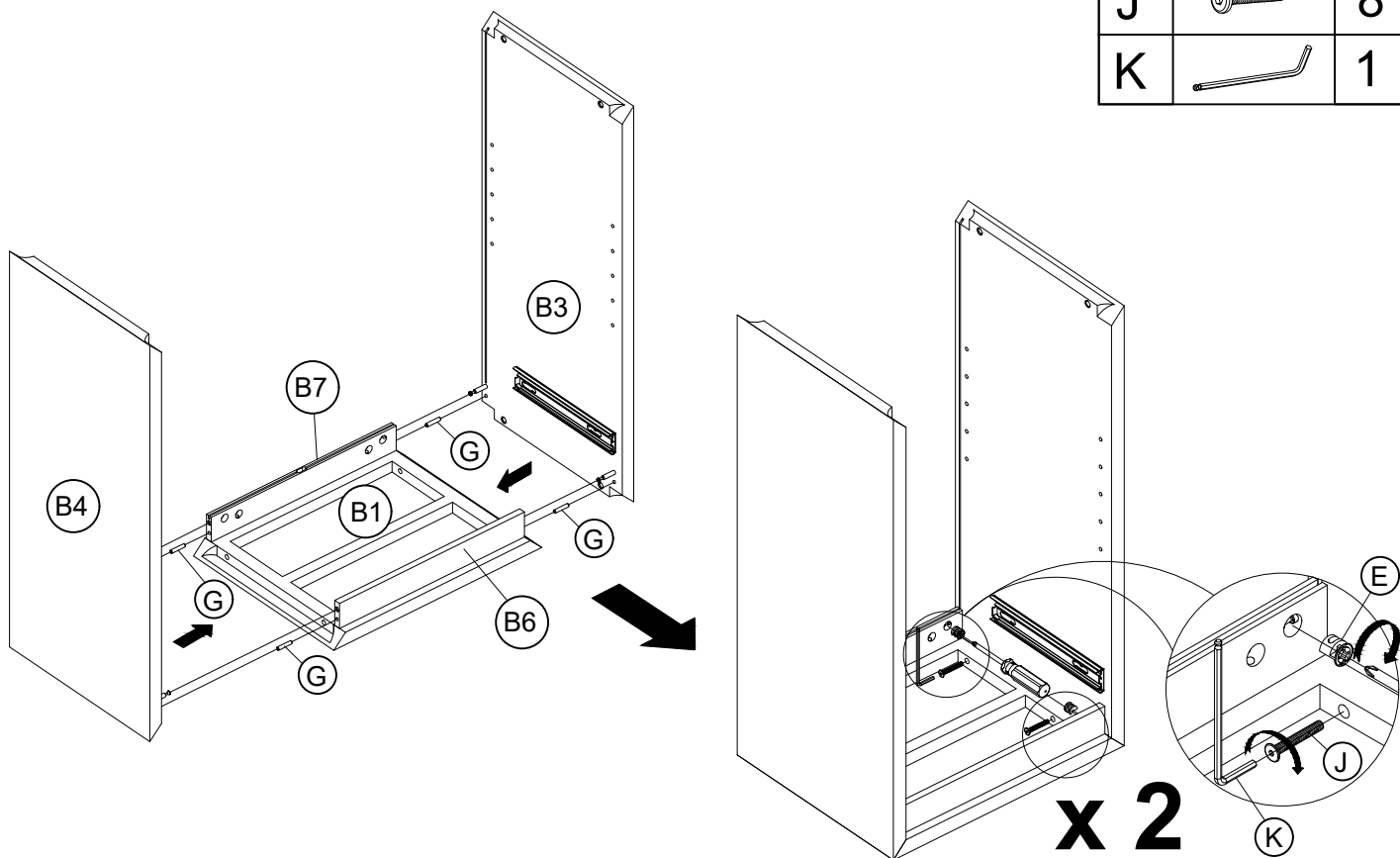
E		8
G		8
J		8
K		1



J		8
K		1

### STEP 17: Following below illustration

-Using hardware #J connect B2,B8 and B9 with B3,B4 assembly step 16

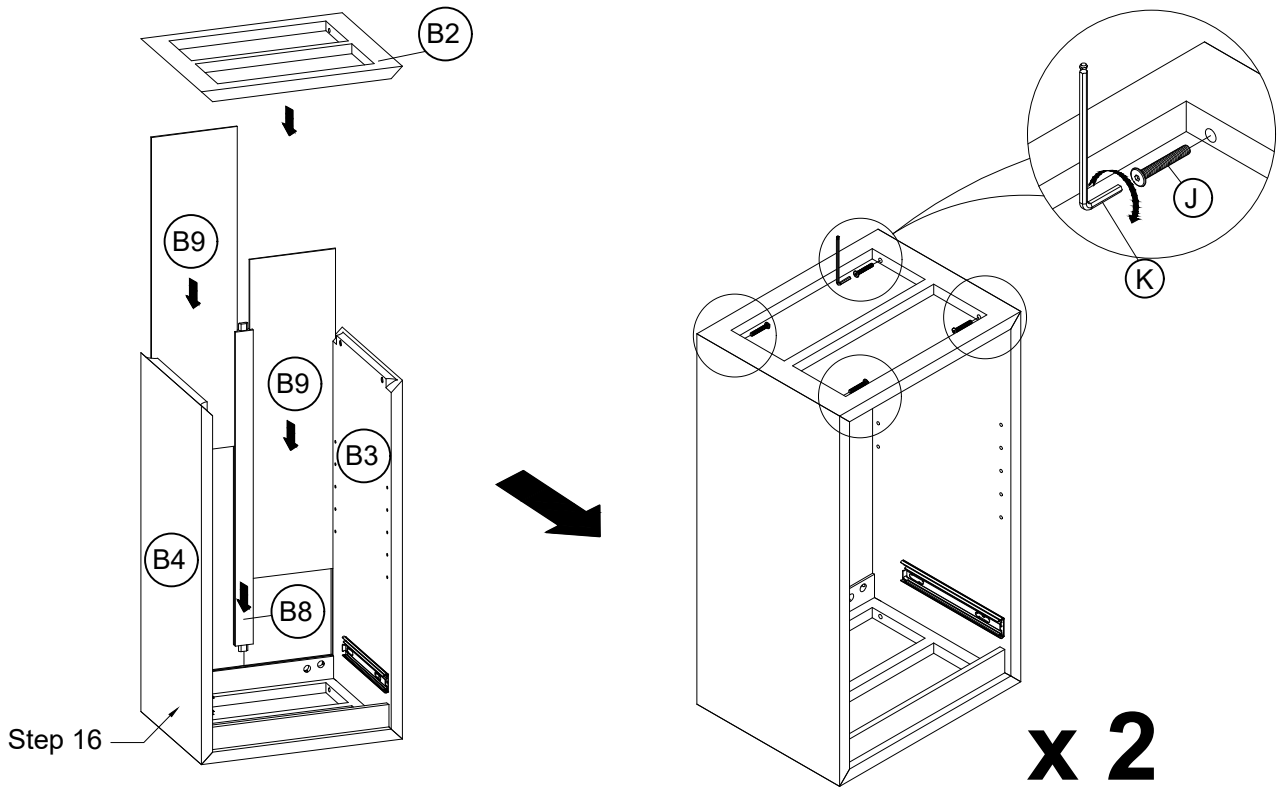

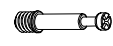

### STEP 18: Following below illustration

-Using hardware #F assembly into B10

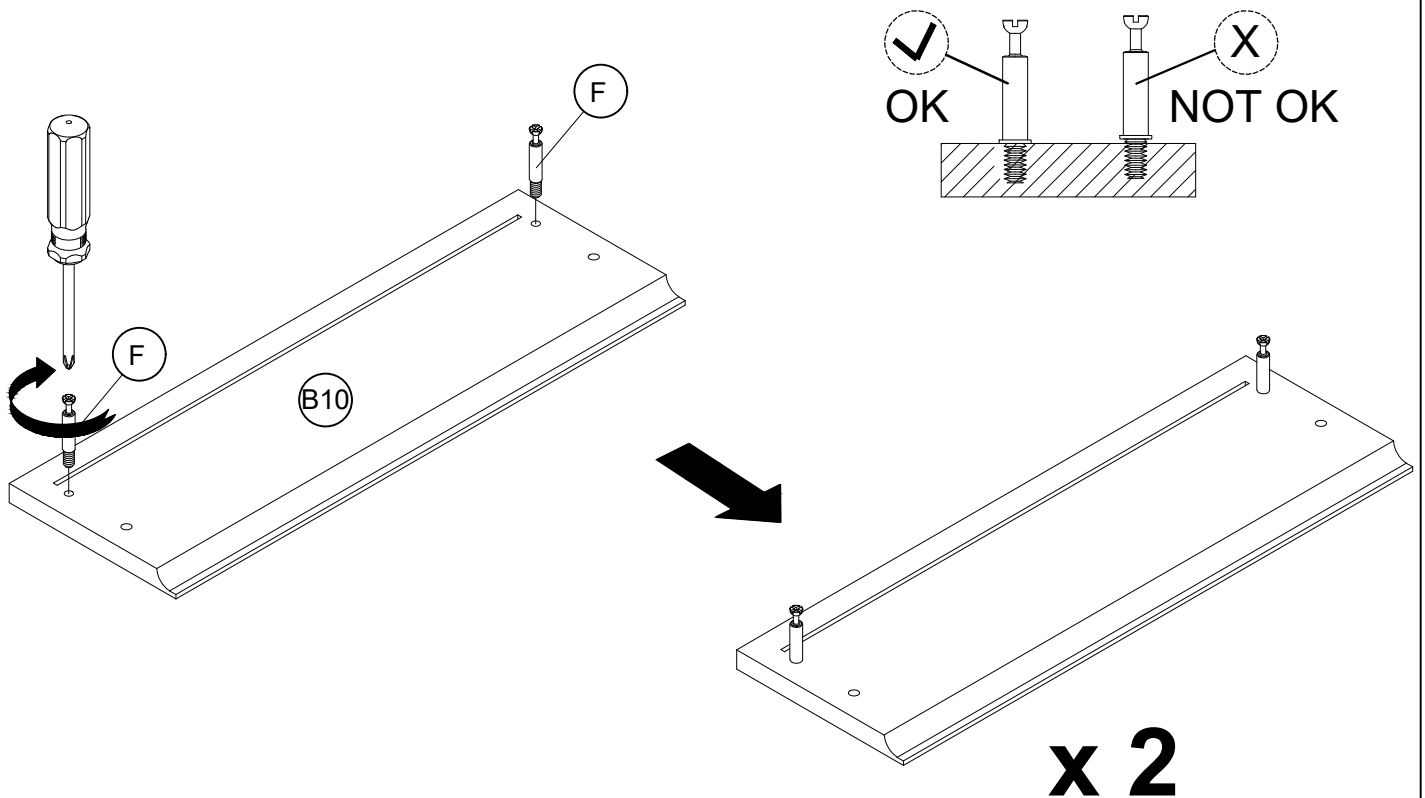
F		4
---	---	---



E		4
G		4

**STEP 19:** Following below illustration

-Using hardware #E, #G connect B10 with B11,B12

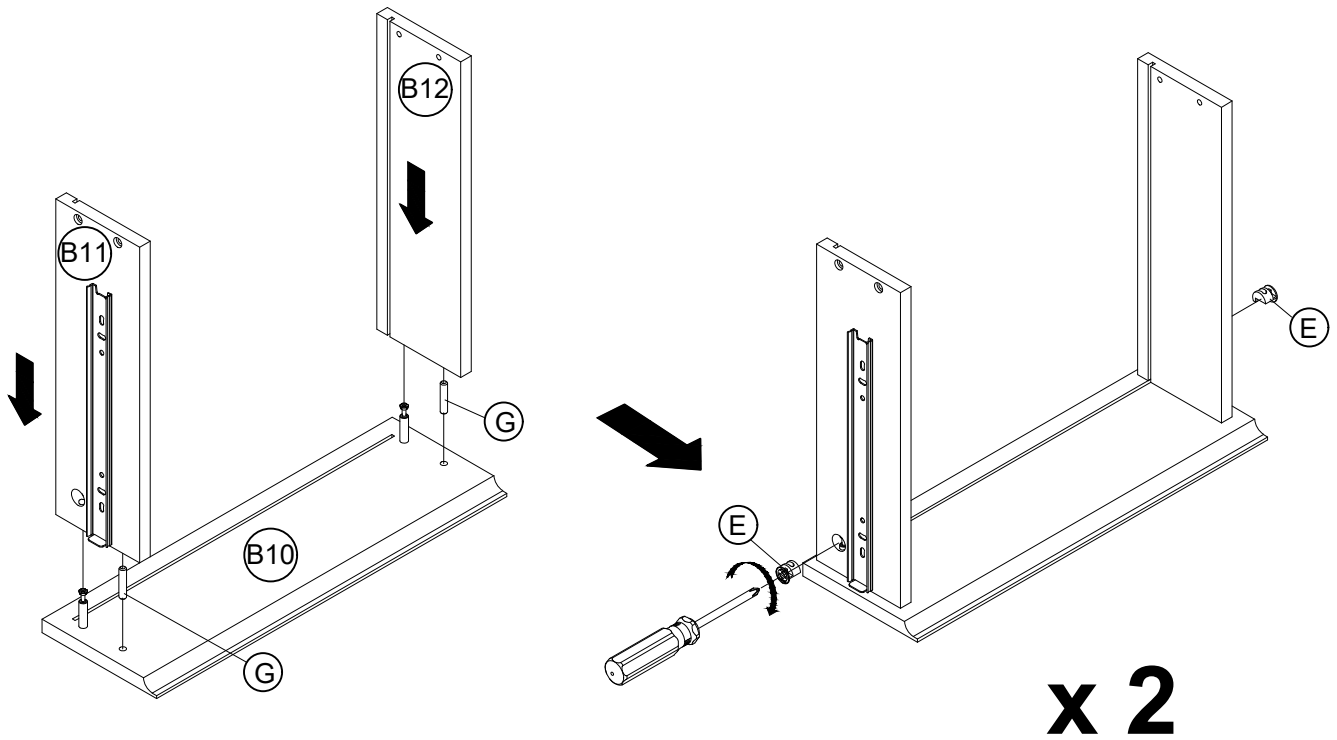

B0		8
----	---	---

**STEP 20:** Following below illustration

-Using hardware #B0 connect B13 with B11,B12 assembly step 19

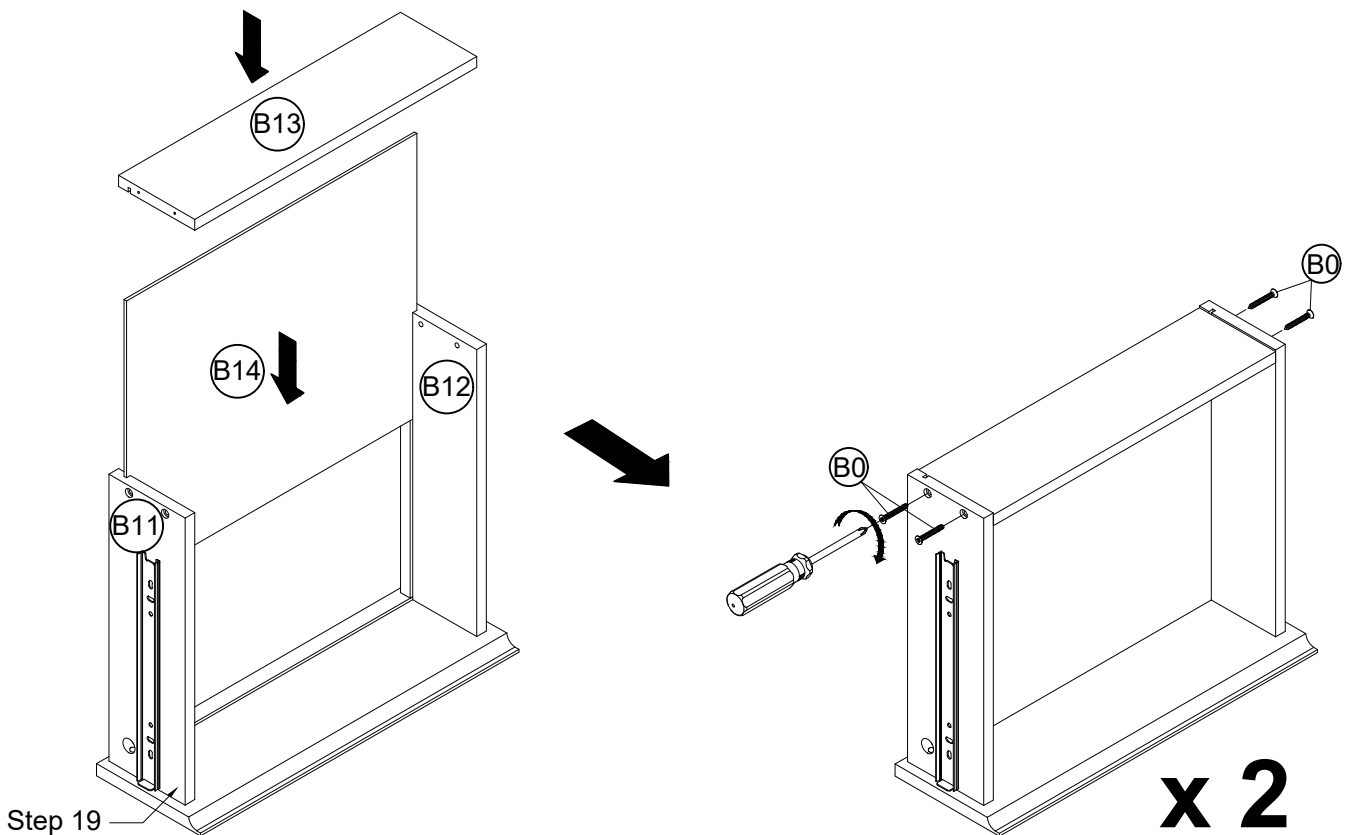

**STEP 21:** Following below illustration

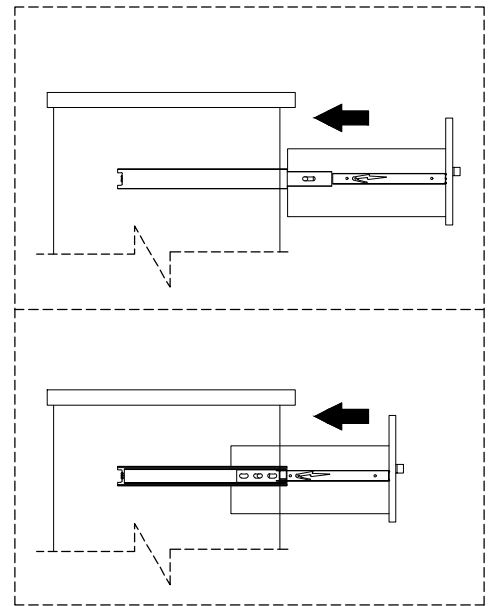
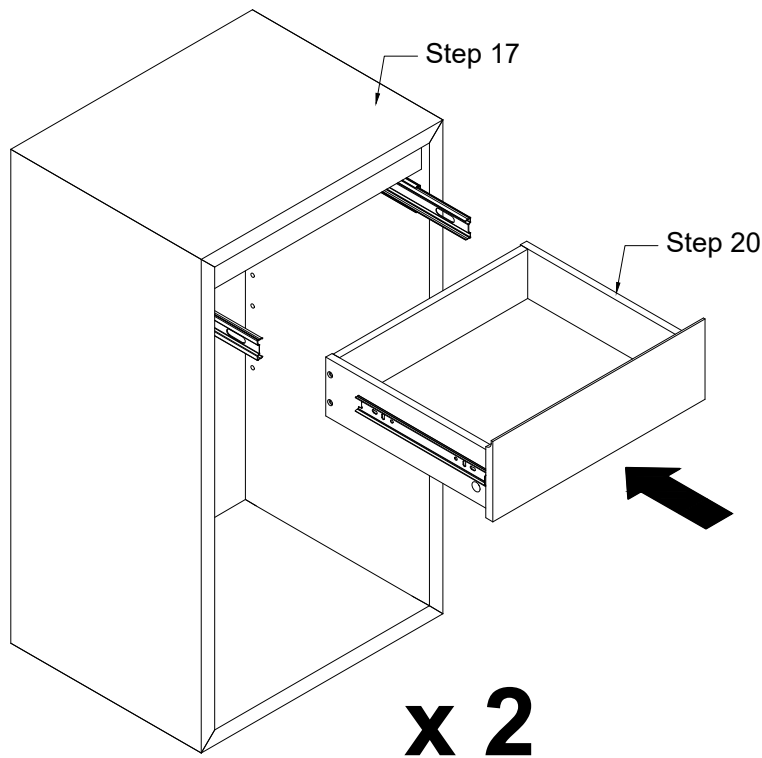



**STEP 22:** Following below illustration

-Using hardware #D connect B5 with B3,B4 assembly step 21

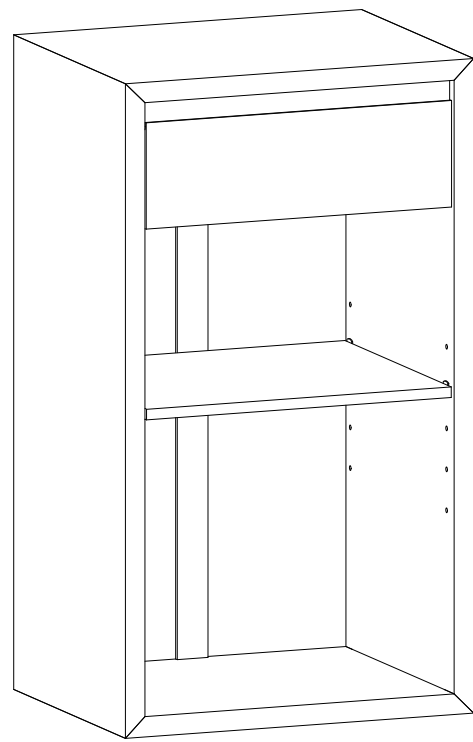
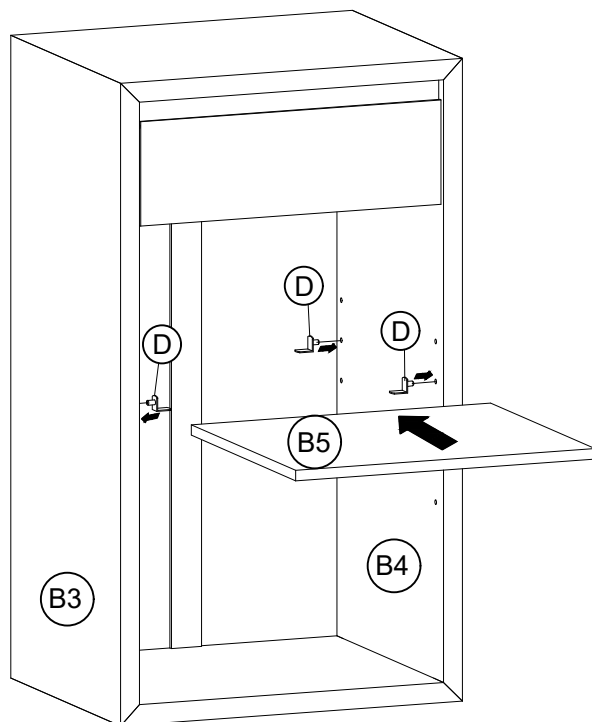
D		8
---	---	---



**x 2**

A0		4
B0		8

**STEP 23:** Following below illustration

-Using hardware #A0,#B0 connect Bench (A) with Cabinet (B)

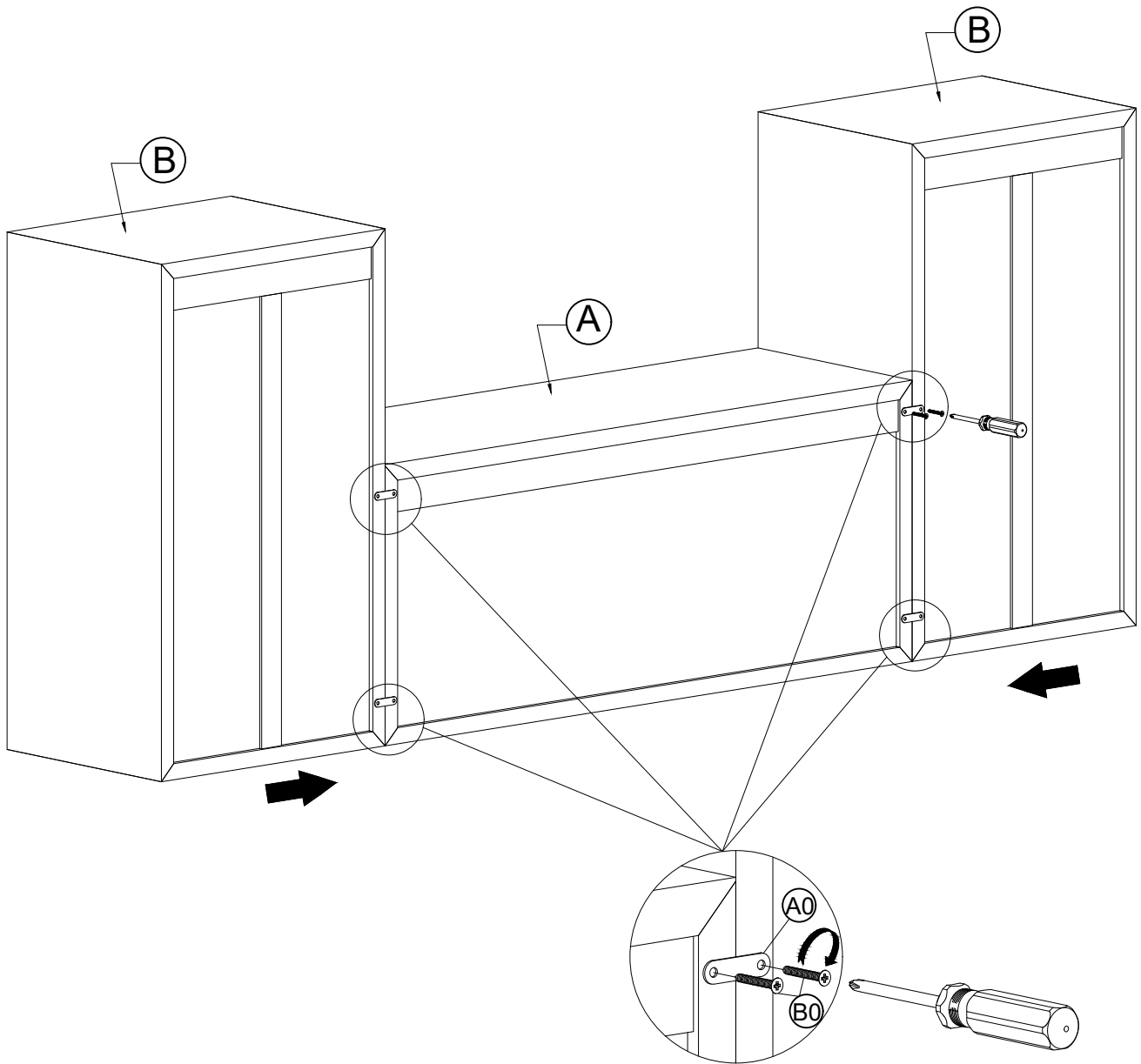

**STEP 24:** Following below illustration

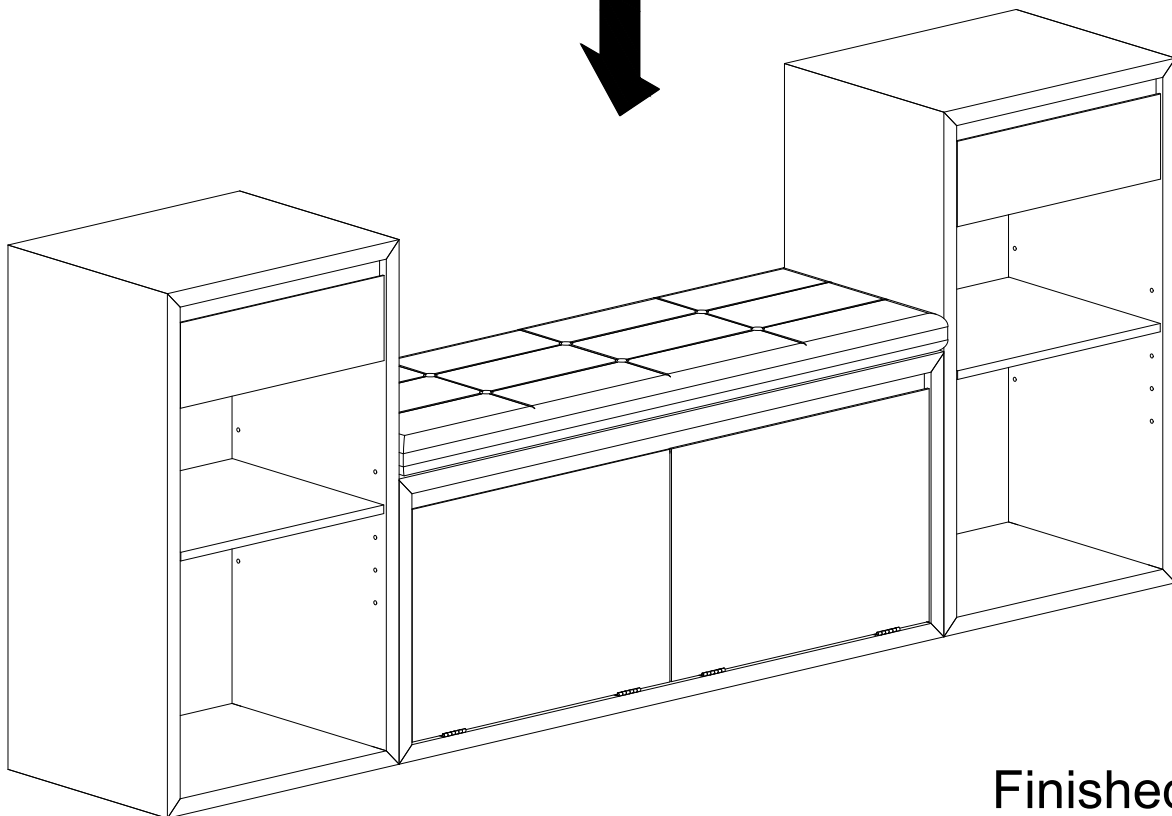
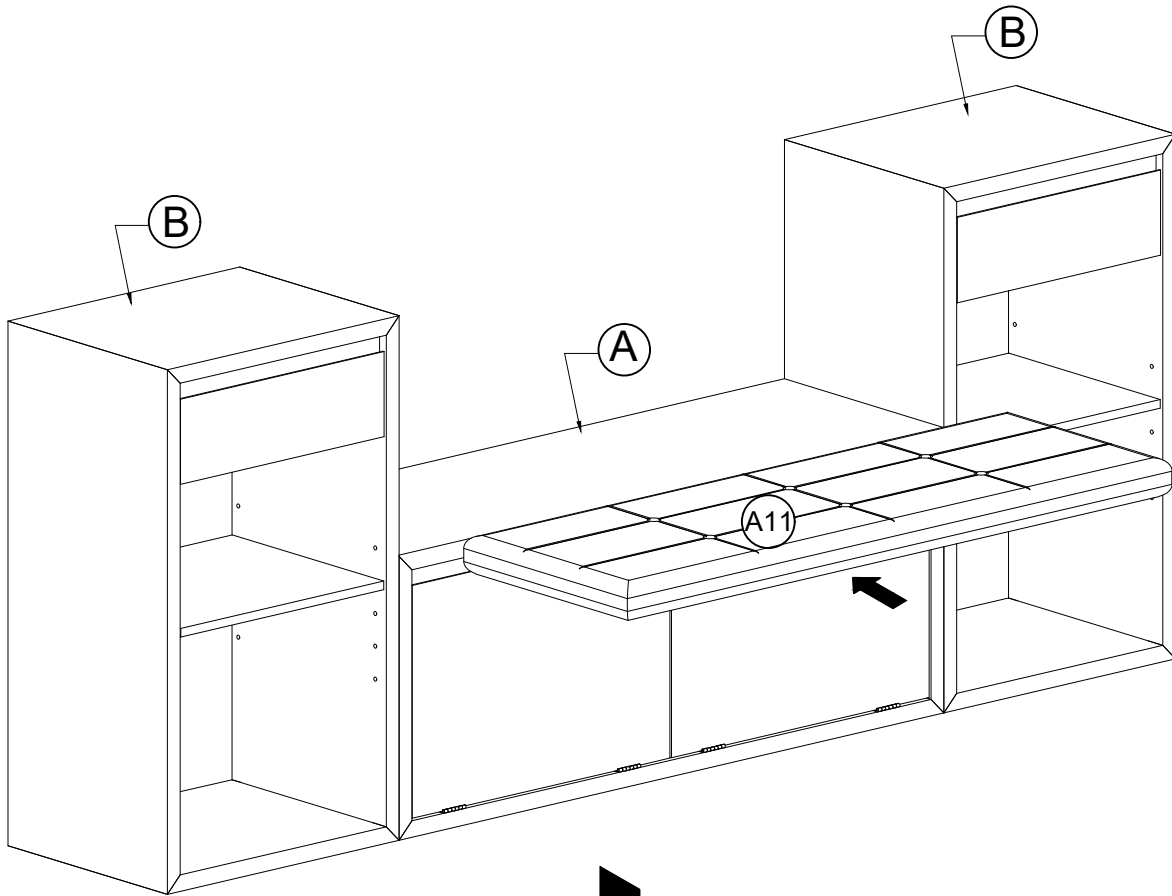

-Put the seat cushion A11 on Bench A



Finished

**! WARNING**

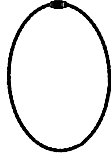
Serious or fatal crushing injuries can occur from furniture tip-over.  
If the furniture tip over restraint kit is not in the box, please contact our customer service department in order to obtain another kit before using the furniture.

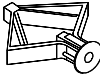
L1		4	L4		2
L2	 M4 X 20mm	2			
L3	 M4 X 40mm	2	L5		2

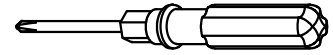

NOTE: The screwdriver is not included in the hardware pack.

It can be attached with a wall plug or not, depending on the wall's hardness.

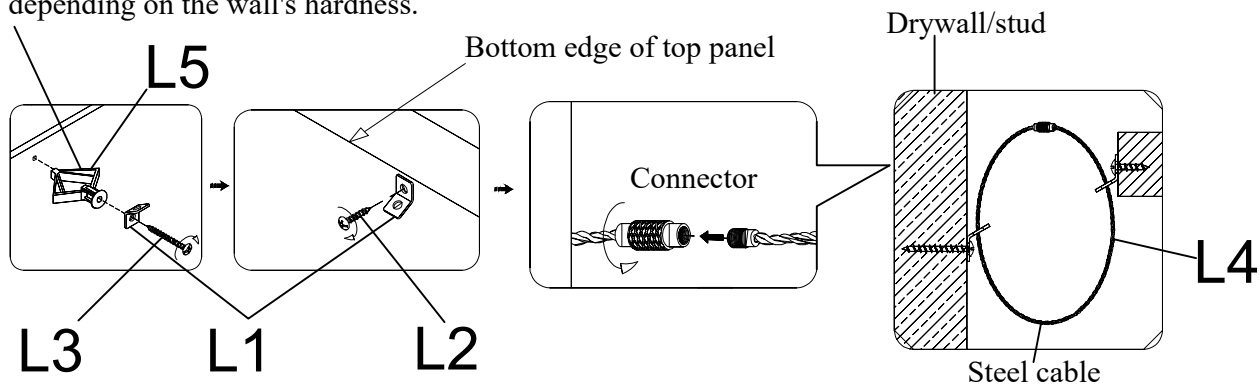

WALL