

COFFEE TABLE

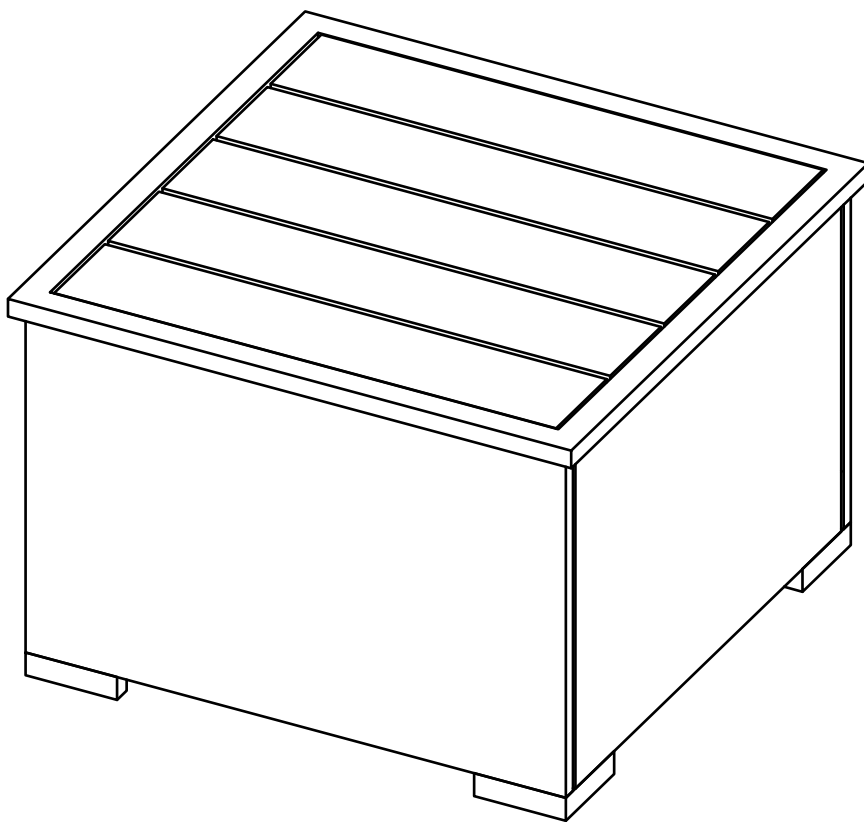





ATTENTION Section:

1. If you encounter any issues, such as missing accessories or damaged parts, please contact us immediately and include pictures.

Assembly Instructions:

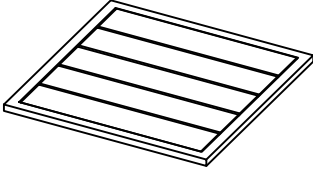
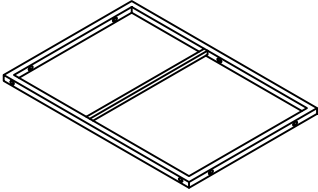
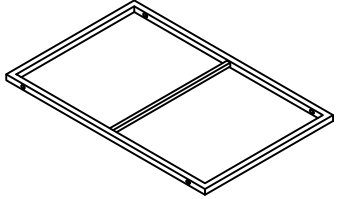
1. Assembly requires two people to complete.
2. For optimal assembly, we highly recommend using the provided Allen key.
If using a power tool, please set it to a low speed to prevent any damage
3. Do not fully tighten the screws until all screws are properly aligned with their holes.

PARTS LIST OF BOX

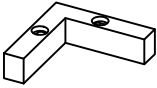
A  PANEL 2pcs	B  SHORT PLATE 4pcs 55.5cm/21.8in	C  LONG PLATE 4pcs 60cm/23.6in
H  2pcs	F  M6*35 44pcs	W  M6 28pcs
G  8pcs		

STEP 1

x2

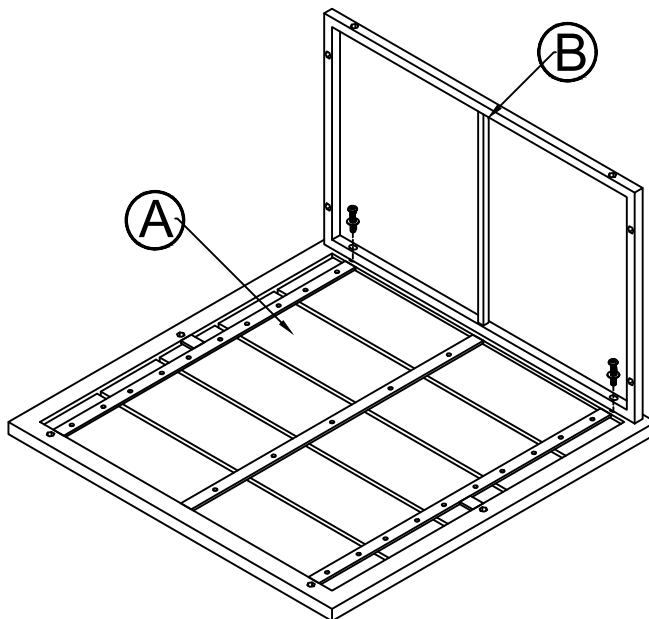
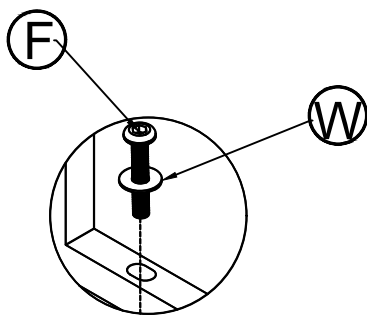

A	1pc	B	1pc	H	1pc	F	2pcs	W	2pcs
				M6		M6*35		M6	

STEP 2

x2

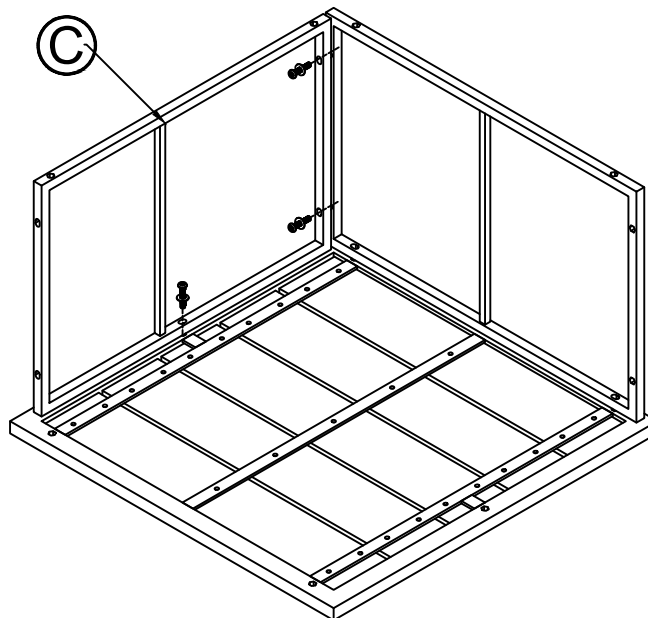
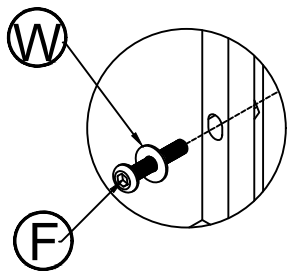





C	1pc	H	1pc	F	3pcs	W	3pcs
		M6		M6*35		M6	

Do not fully tighten all screws until assembly is completed.

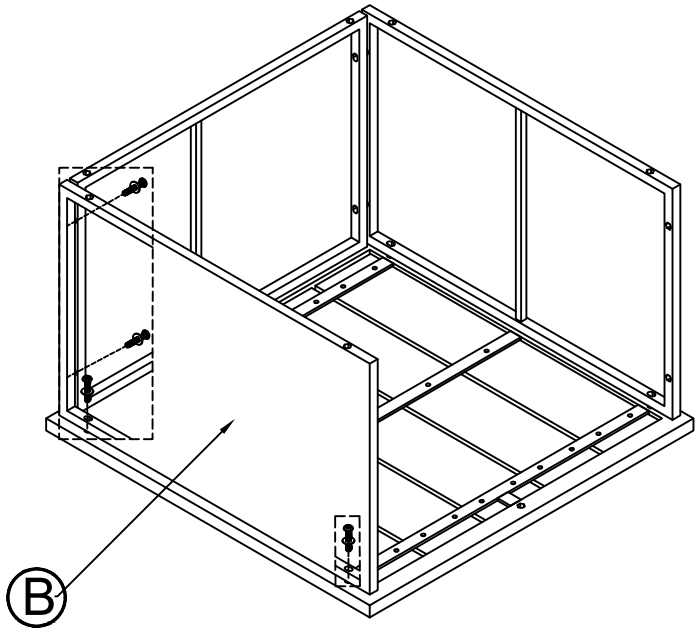
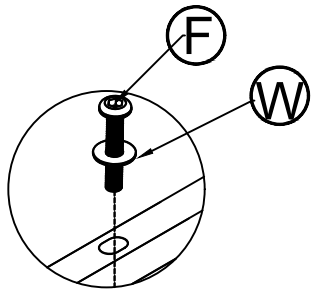
STEP 3

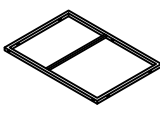
x2





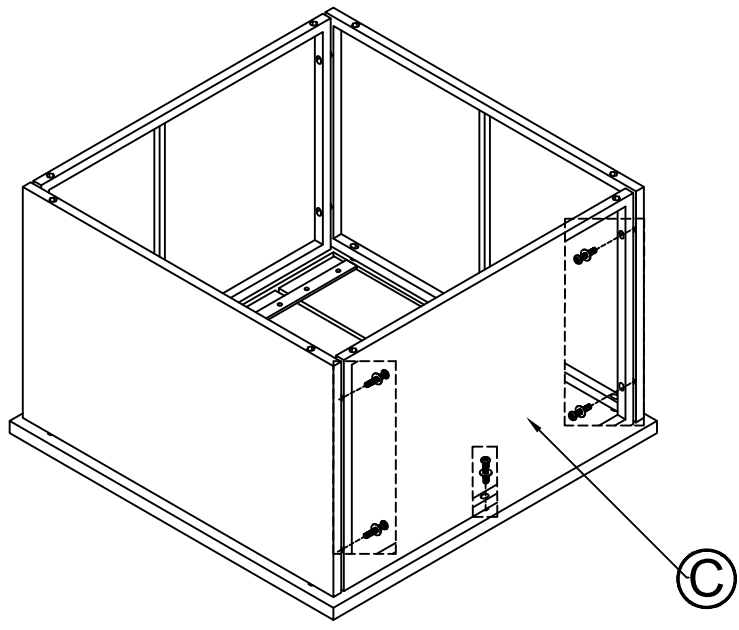
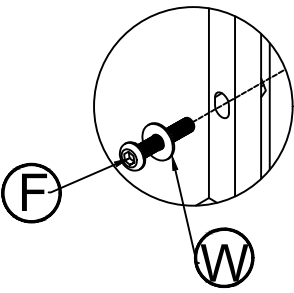

B	1pc	H	1pc	F	4pcs	W	4pcs
							
		M6		M6*35		M6	

STEP 4

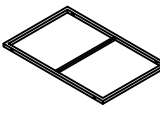

x2

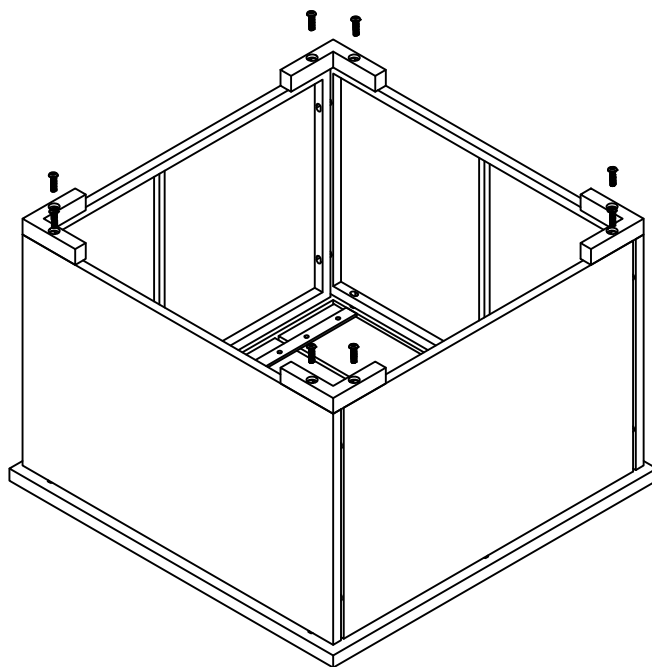
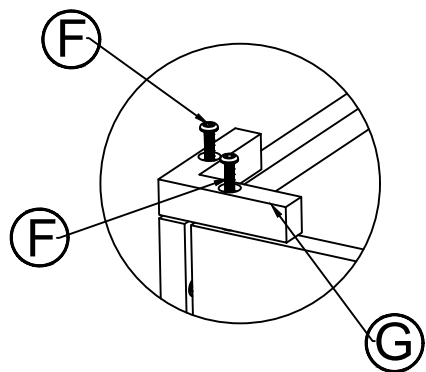

C	1pc	H	1pc	F	5pcs	W	5pcs
							
		M6		M6*35		M6	

Do not fully tighten all screws until assembly is completed.



G	4pcs	H	1pc	F	8pcs
					
		M6		M6*35	

Do not fully tighten all screws until assembly is completed.