

Assembly Instructions

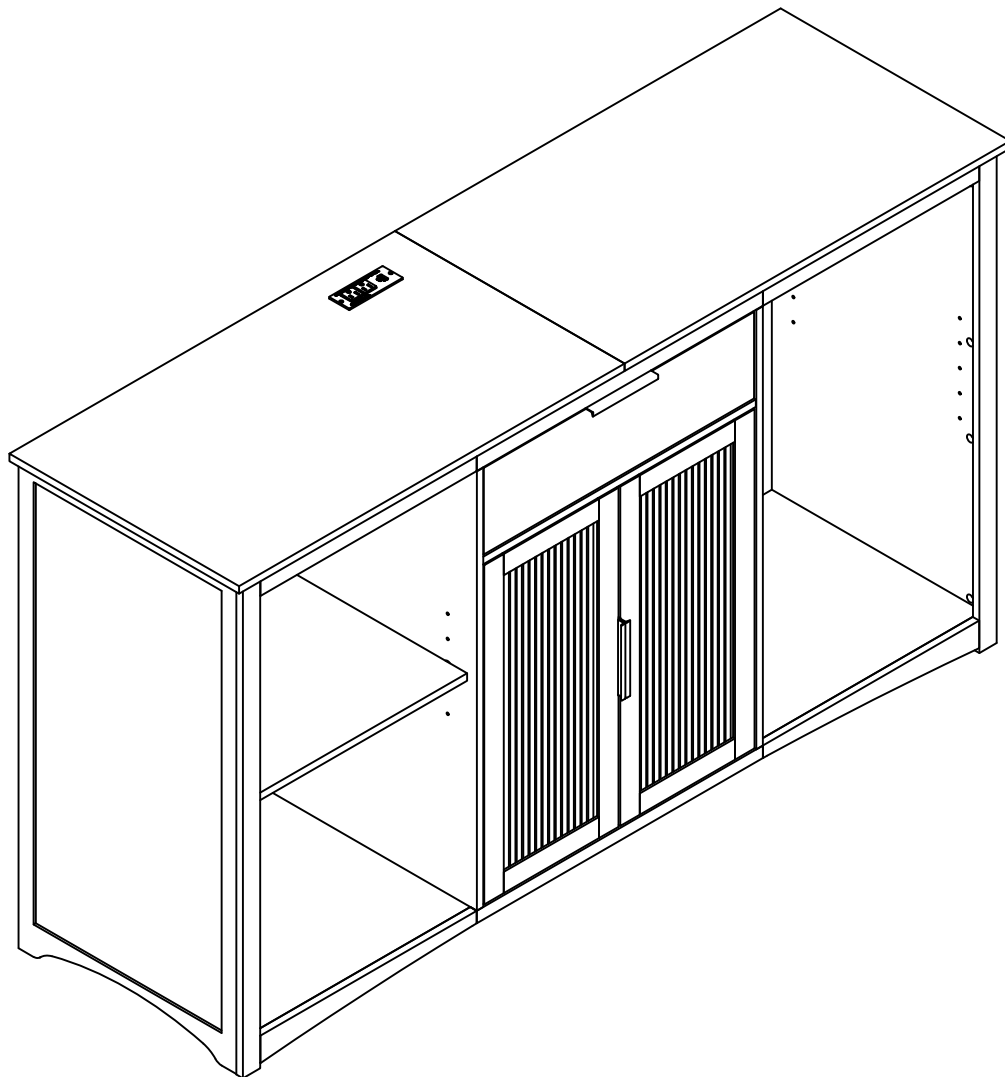

We come with the necessary tools for assembly, but for faster assembly, a power drill is recommended.

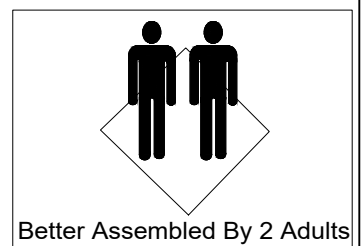



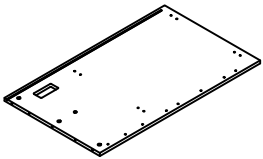
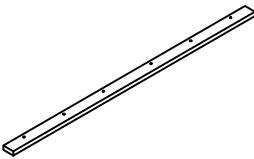
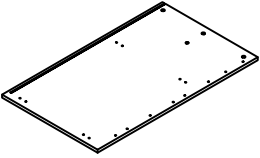
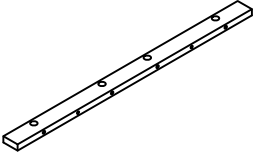
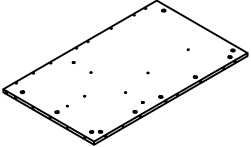
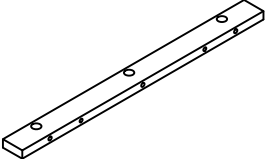
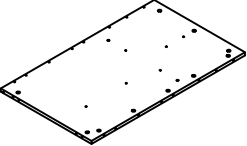
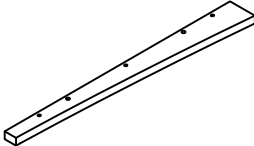
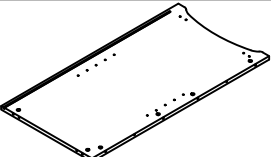
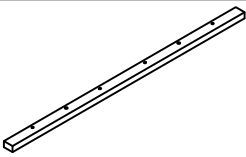
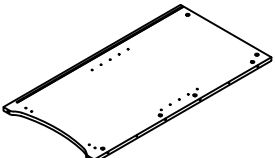
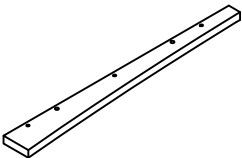
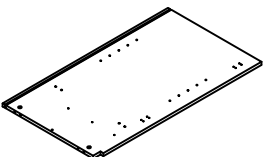
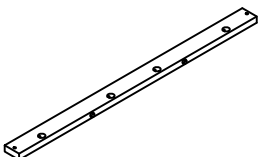
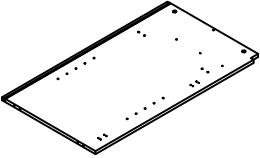
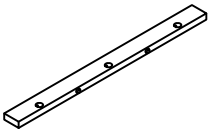
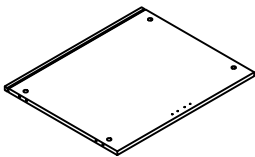
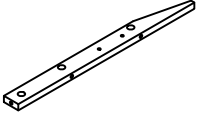
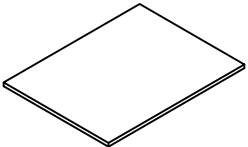
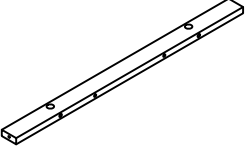
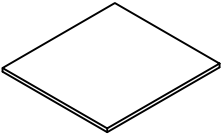
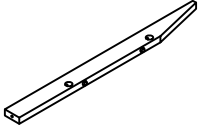



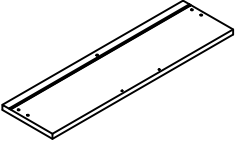
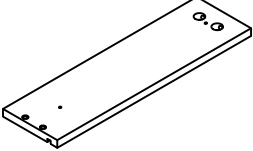
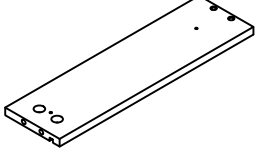
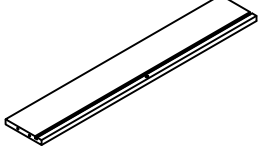
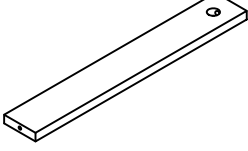
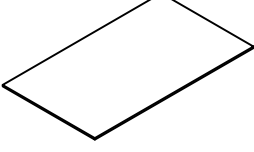
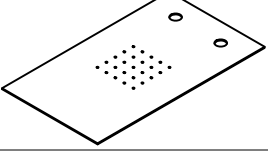
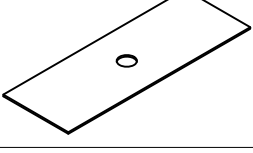
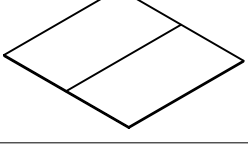
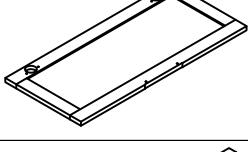
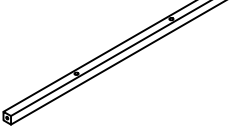



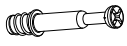



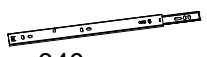

Parts List

ITEM	PART	QTY	ITEM	PART	QTY
①		1PC	⑫		2PCS
②		1PC	⑬		1PC
③		1PC	⑭		2PCS
④		1PC	⑮		1PC
⑤		1PC	⑯		1PC
⑥		1PC	⑰		1PC
⑦		1PC	⑱		1PC
⑧		1PC	⑲		2PCS
⑨		1PC	⑳		2PCS
⑩		1PC	㉑		1PC
⑪		1PC	㉒		2PCS

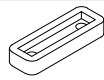
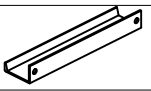
Parts List

ITEM	PART	QTY
23		1PC
24		1PC
25		1PC
26		1PC
27		1PC
28		1PC
29		2PCS
30		1PC
31		1PC
32		2PCS
33		1PC

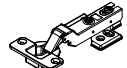
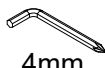
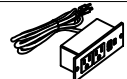
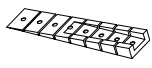
Hardware List

ITEM	PART	QTY	ITEM	PART	QTY
A	 Ø6x35mm	71+5 PCS	K		8+1 PCS
B	 Ø15x10mm	83+5 PCS	L	 M6x40mm	2+1 PCS
C	 Ø6x30mm	48+4 PCS	M	 M6x30mm	2+1 PCS
D	 Ø5x38mm	13+1 PCS	N		38+3 PCS
E	 340mm	2 PCS		 Ø6xØ3x16mm	38+3 PCS
F	 Ø6xØ3x12mm	24+2 PCS	O		2 PCS
G		3 PCS	P	 Ø20mm	36+4 PCS
H	 Ø7xØ3.5x14mm	24+2 PCS	Q		6+1 PCS
I		4 PCS	R	 4mm	1 PC
J		1 PC	S		6 PCS
		1 PC			

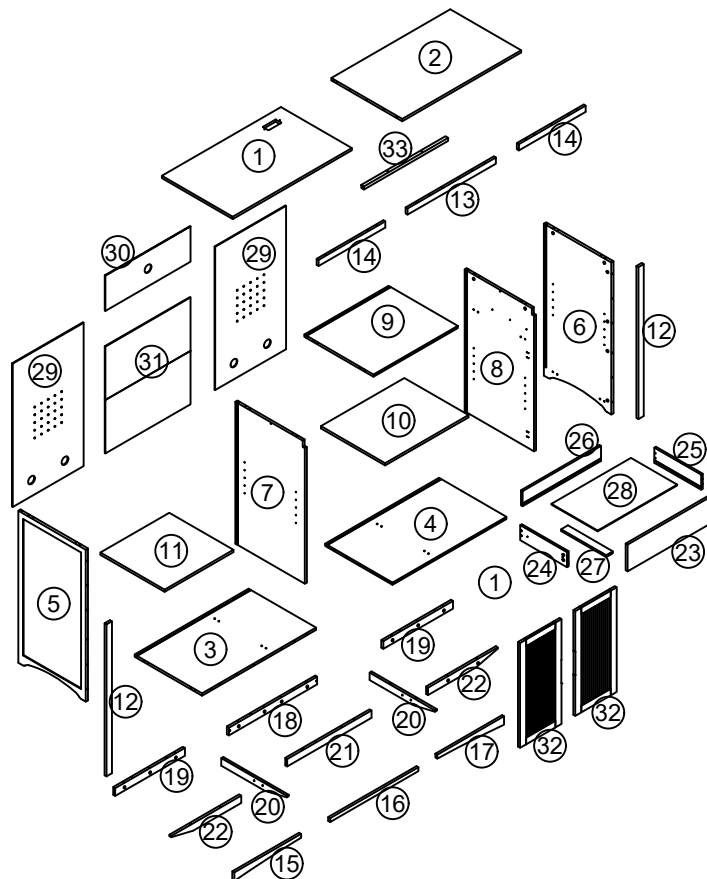

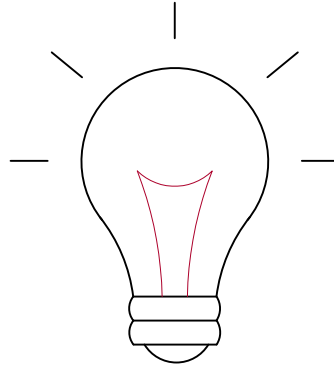

friendly reminder

To avoid errors and confusion during the installation of accessories, use the type and quantity of hardware accessories according to the installation procedure described in the instructions. First, unroll the accessories bag and lay out the hardware accessories, cut holes in the side, and take out the hardware accessories

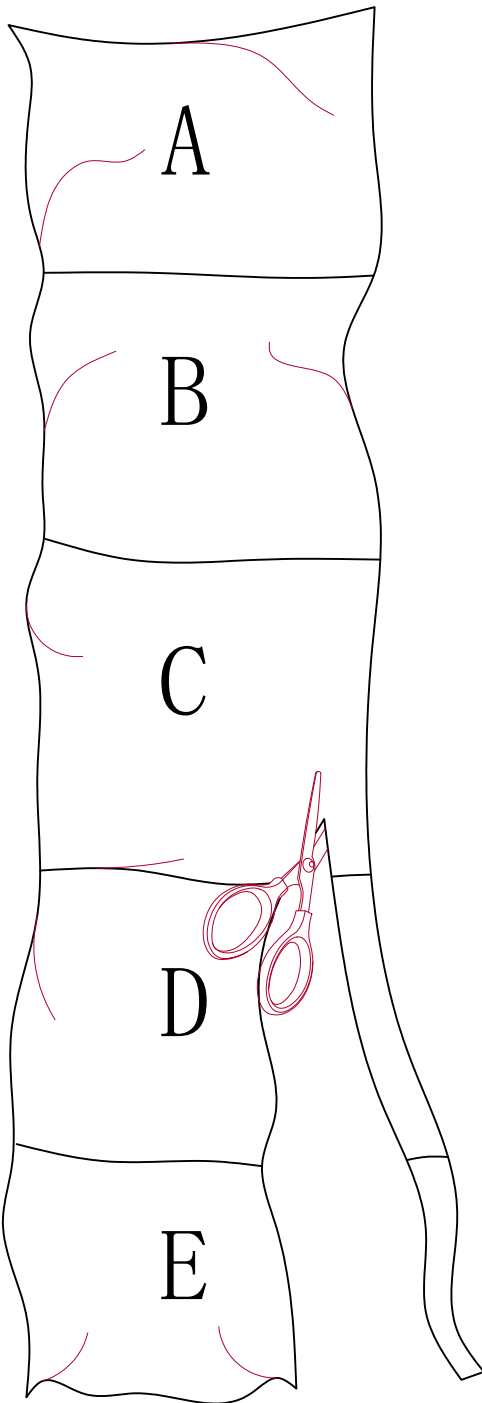

01

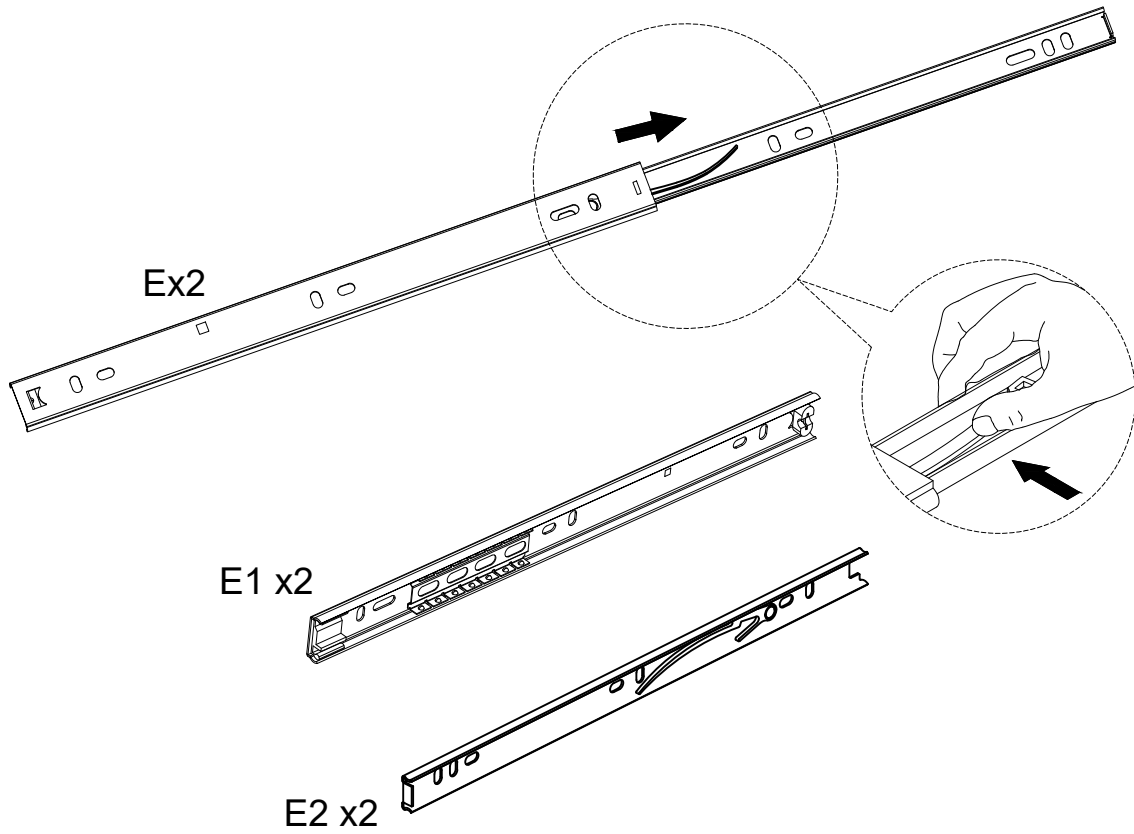

Extend slides E x2, then push the release lever upward to detach the outer rail E1 x2 and the inner rail E2 x2 as shown.



02

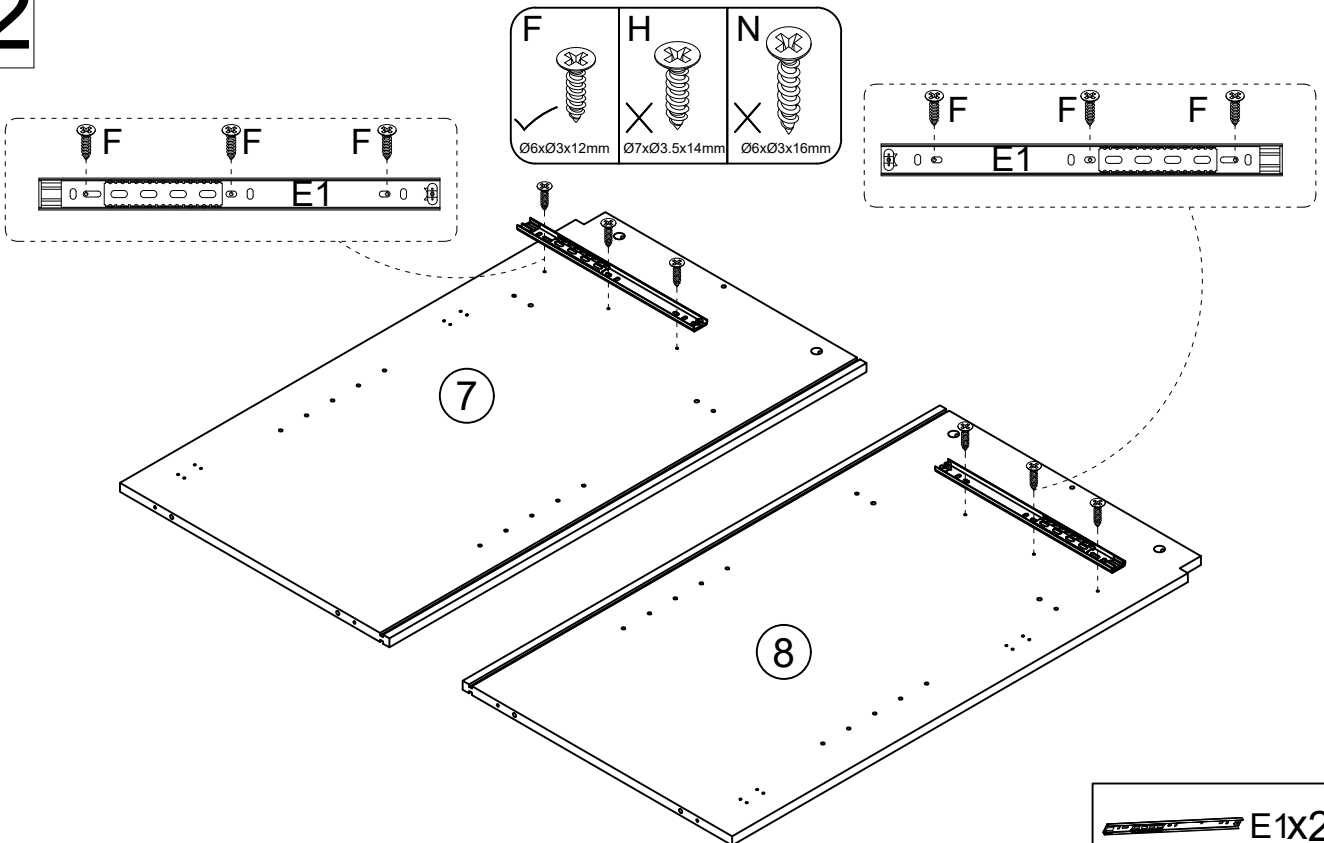

Install the outer rail E1 x2 to Part #7 and Part #8 with screws F x6 as shown.



03

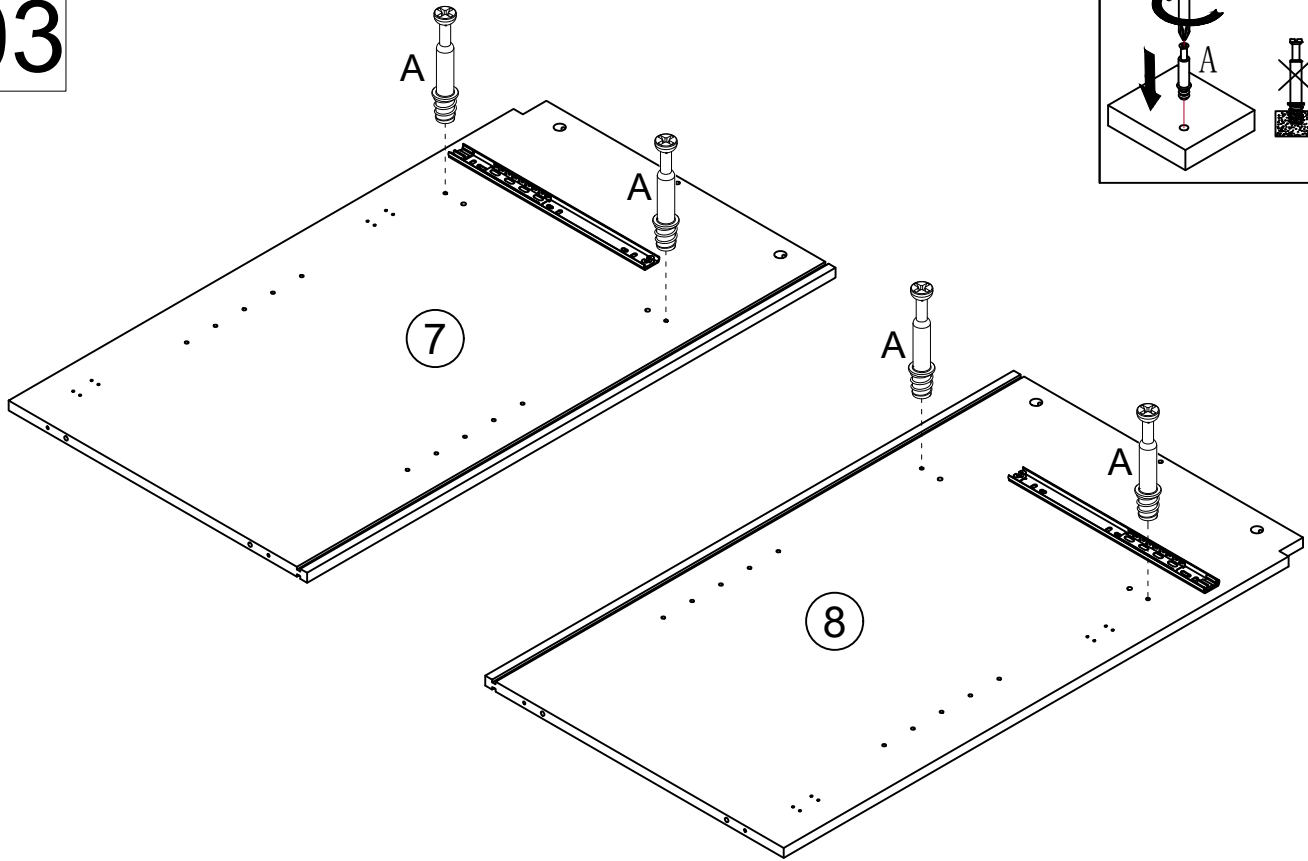

Install Cam Bolt A x4 to Part #7 and Part #8 as shown.



04

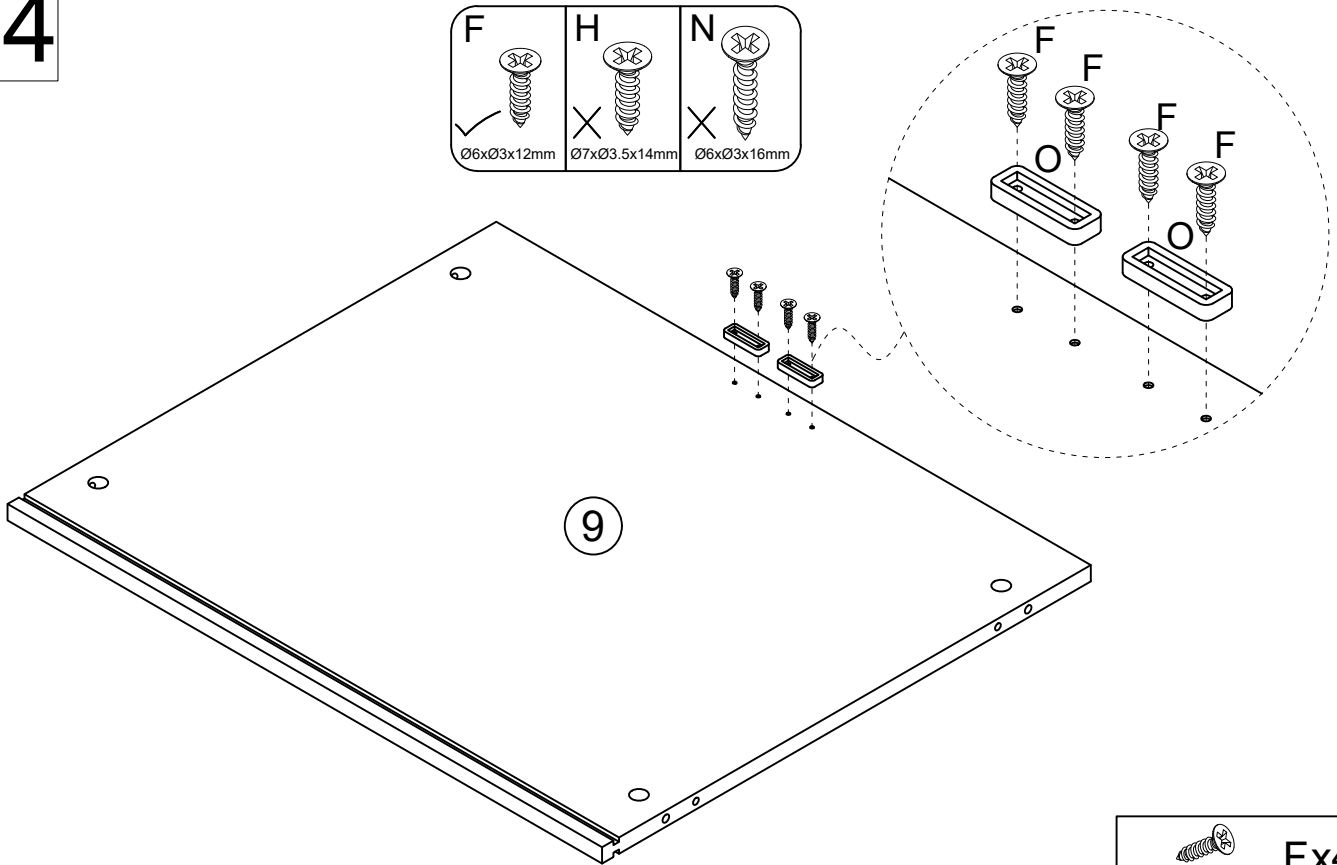

Install O x2 to Part #9 with screws F x4 as shown.

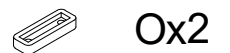

05

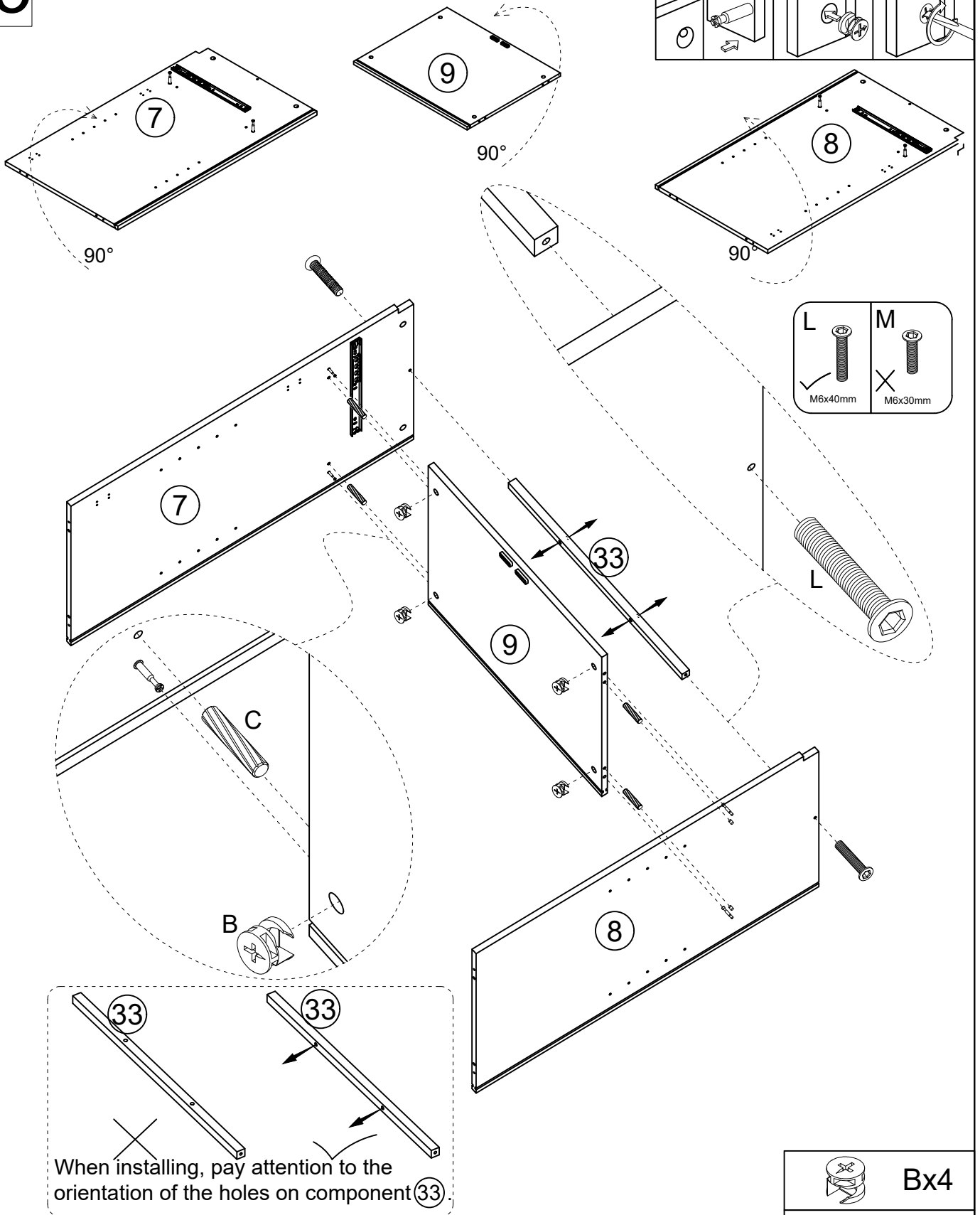
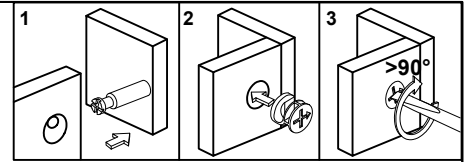

Attach Part #7&8 to Part #9 with dowel C x4 and nuts B x4 as shown.

Attach Part #7&8 to Part #33 with screws L x2 as shown.

Then turn nuts B x4 to secure position.

	Bx4
	Cx4
	Lx2
	Rx1

06

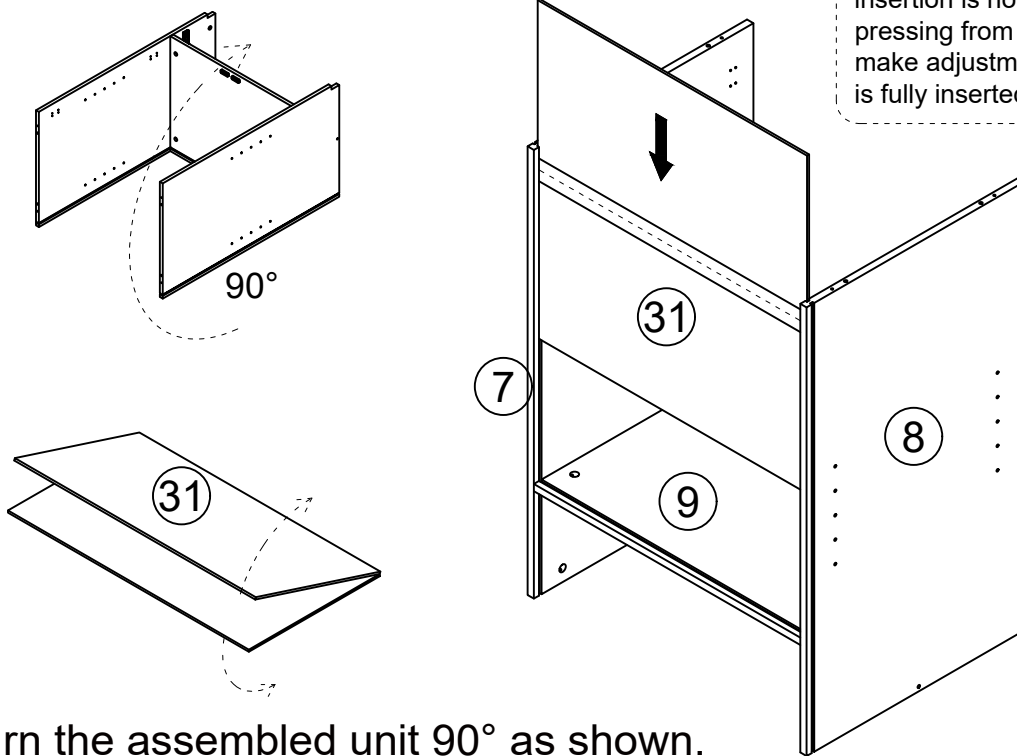

The thin plate needs to be fully inserted into the groove. If the insertion is not smooth, you can try pressing from the front or the back to make adjustments until the thin plate is fully inserted into the groove.

Turn the assembled unit 90° as shown.
 Unfold Part #31 and insert it into the grooves of the assembled unit as shown.

07

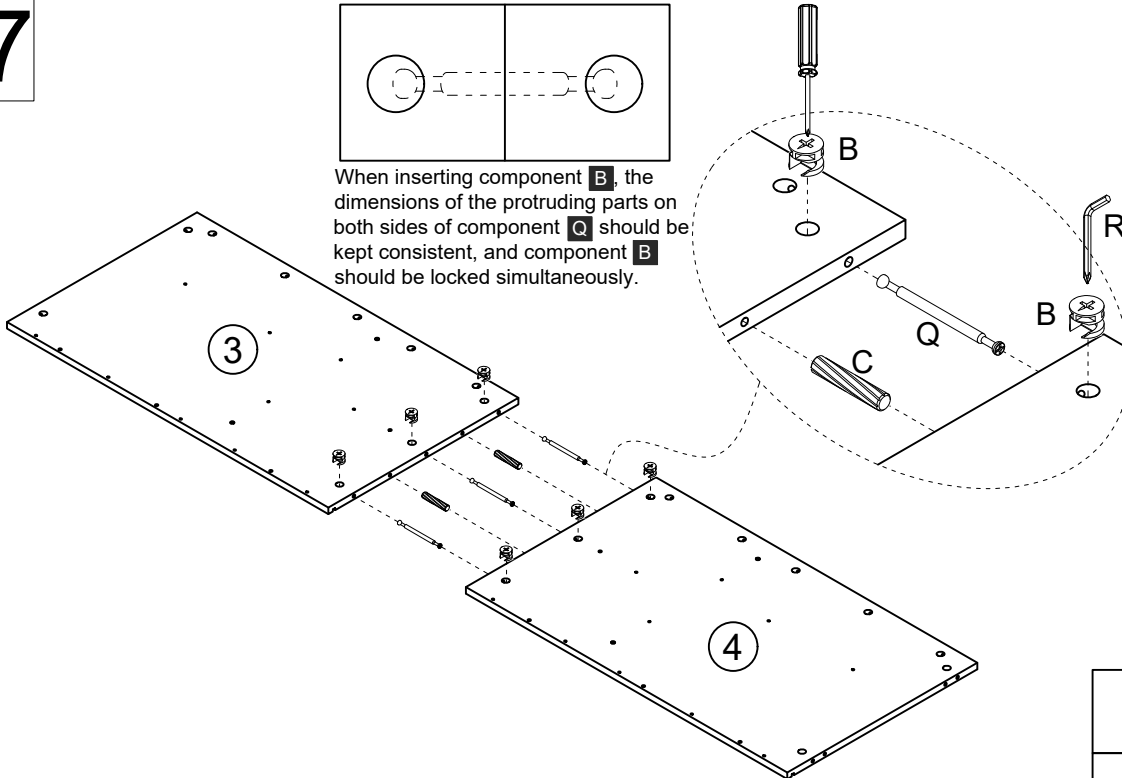

When inserting component **B**, the dimensions of the protruding parts on both sides of component **Q** should be kept consistent, and component **B** should be locked simultaneously.

Connect Part #3 to Part #4 with Q x3, dowel C x2, and nuts B x6 as shown.
 Then tighten the nuts B on both sides of each Q simultaneously using a screwdriver and tool R as shown.

	Bx6
	Cx2
	Qx3
	Rx1

08

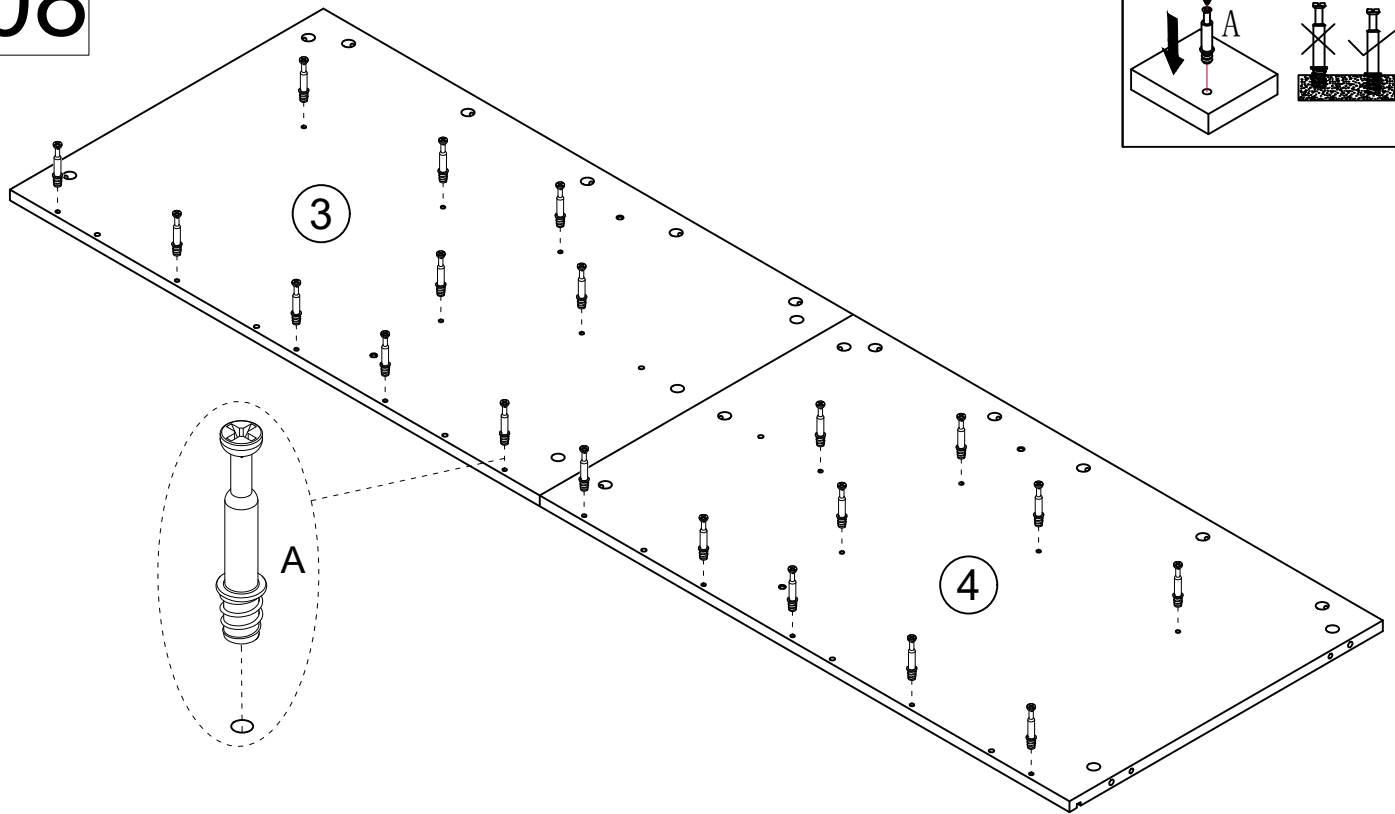

Install Cam Bolt A x20 to Part #3 and Part #4 as shown.



09

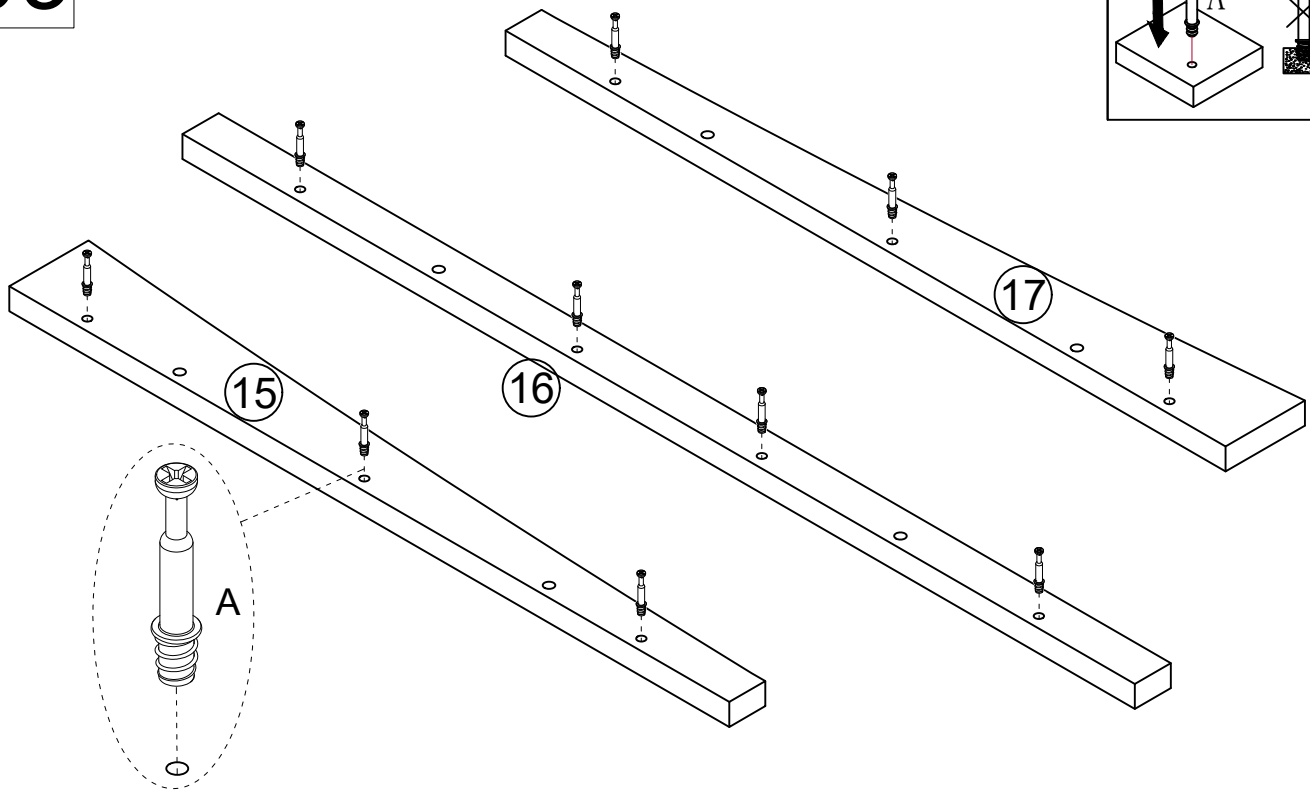

Install Cam Bolt A x10 to Part #15, #16 and #17 as shown.



10

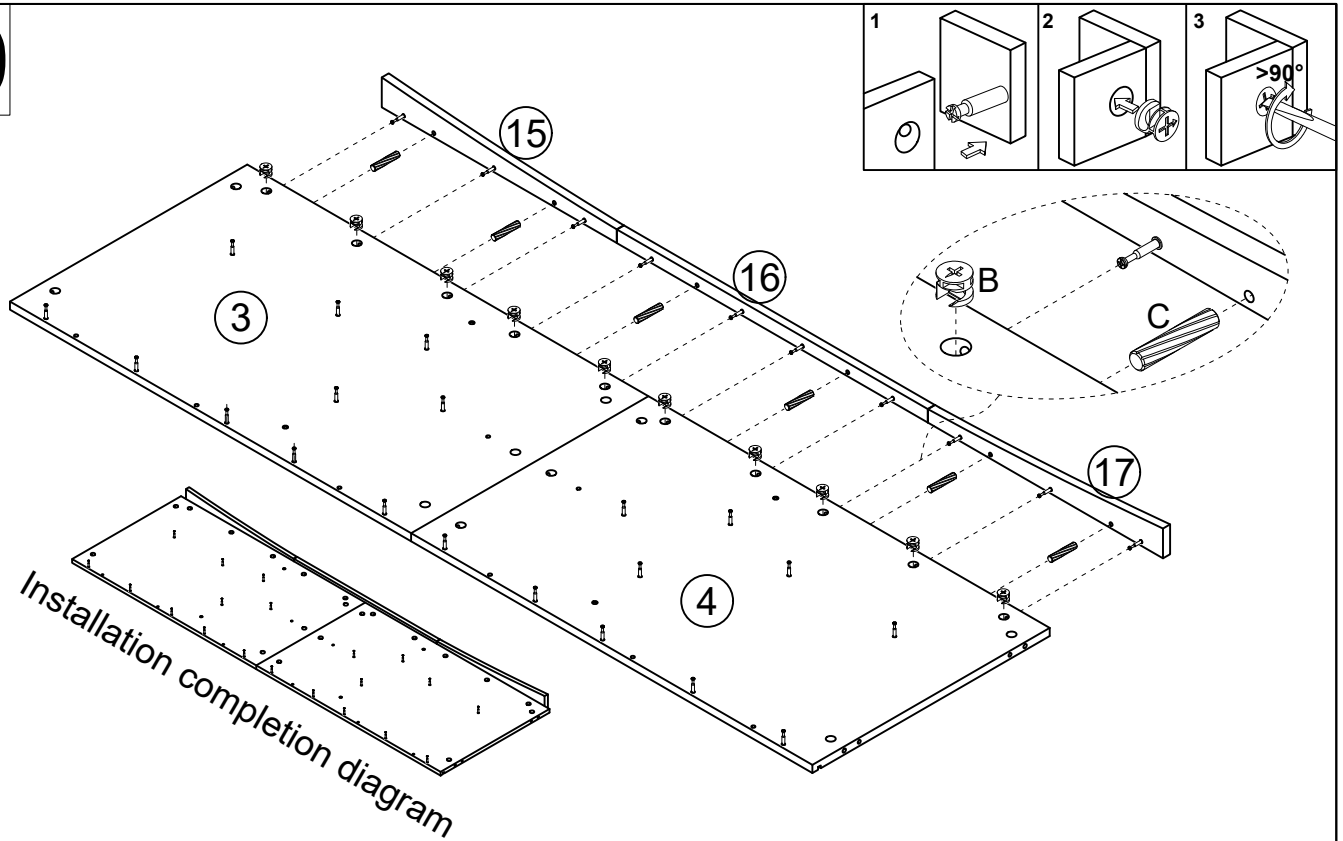

Attach Part #15, #16 and #17 to Part #3&4 with dowel C x6 and nuts B x10 as shown.
Then turn nuts B x10 to secure position.

	Bx10
	Cx6

11

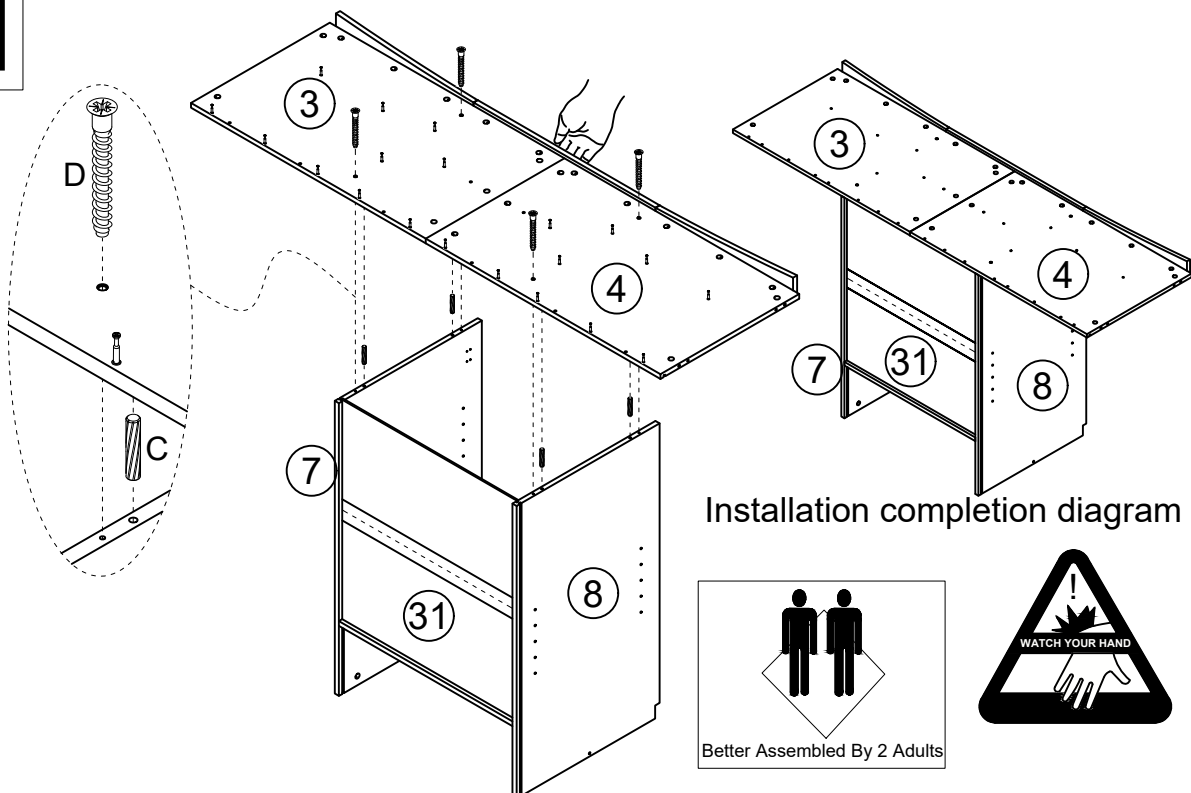

Attach Part #3&4 to Part #7&8 with dowel C x4 and screws D x4 as shown.
This step should be carried out by two adults.

	Cx4
	Dx4

12

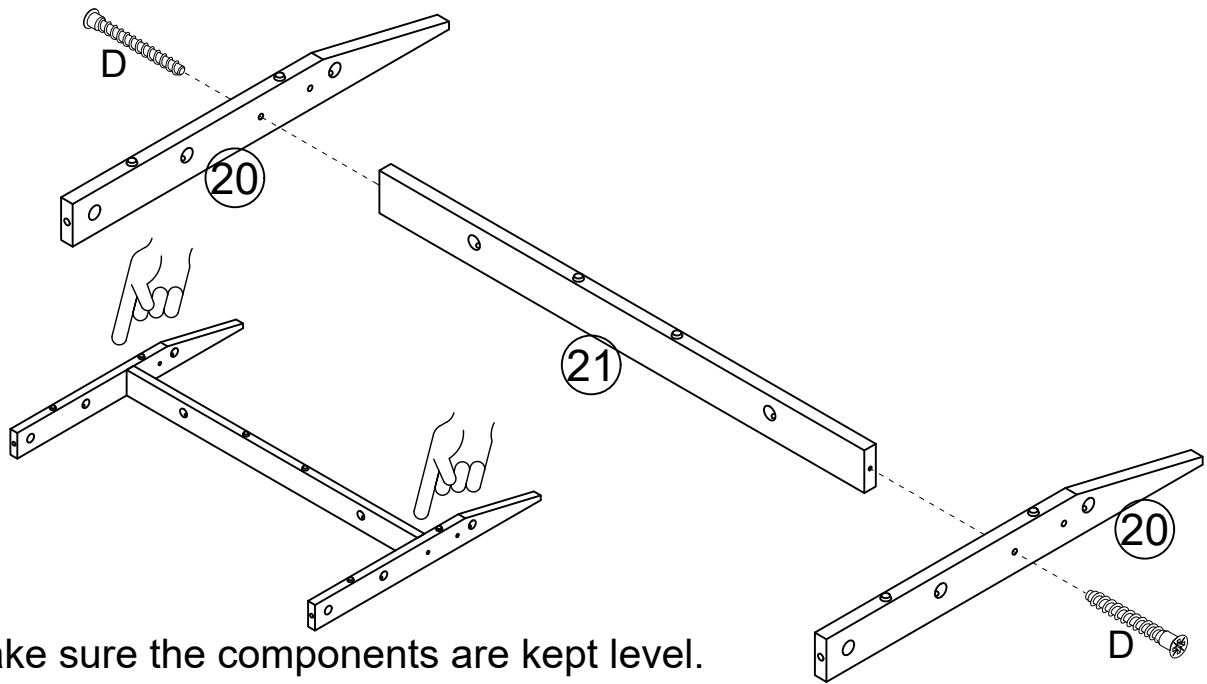

Make sure the components are kept level.

Attach Part #20 x2 to Part #21 with screws D x2 as shown.

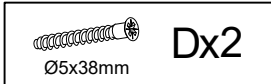

13

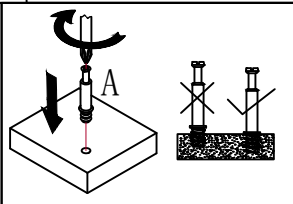
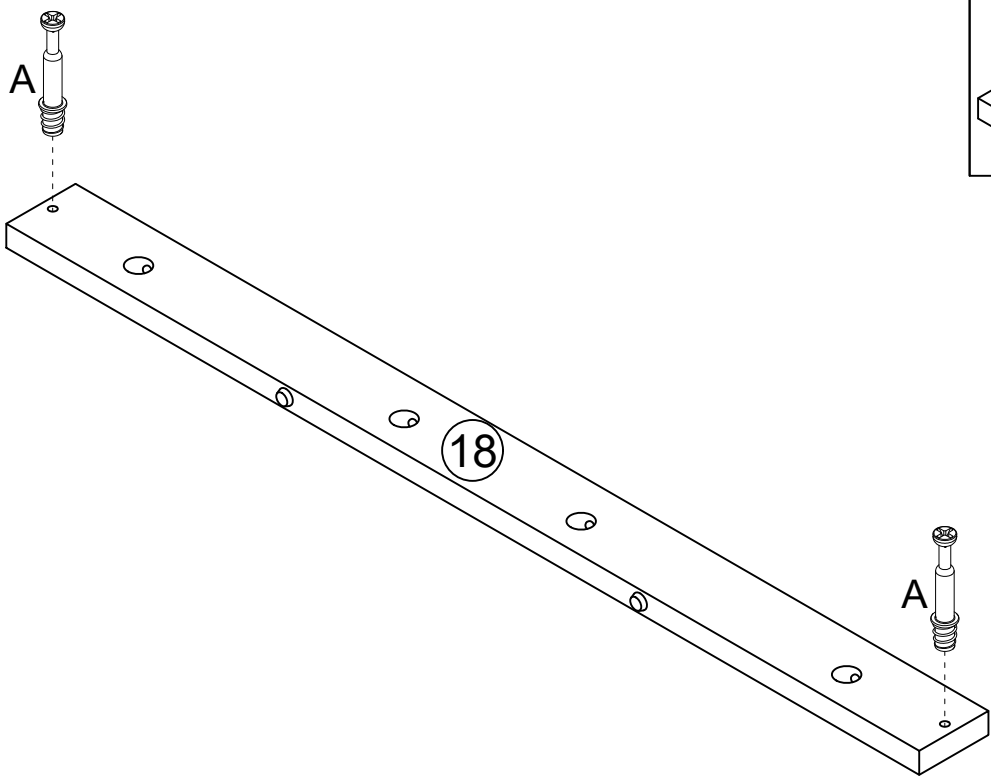

Install Cam Bolt A x2 to Part #18 as shown.

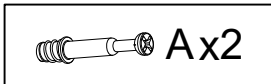

14

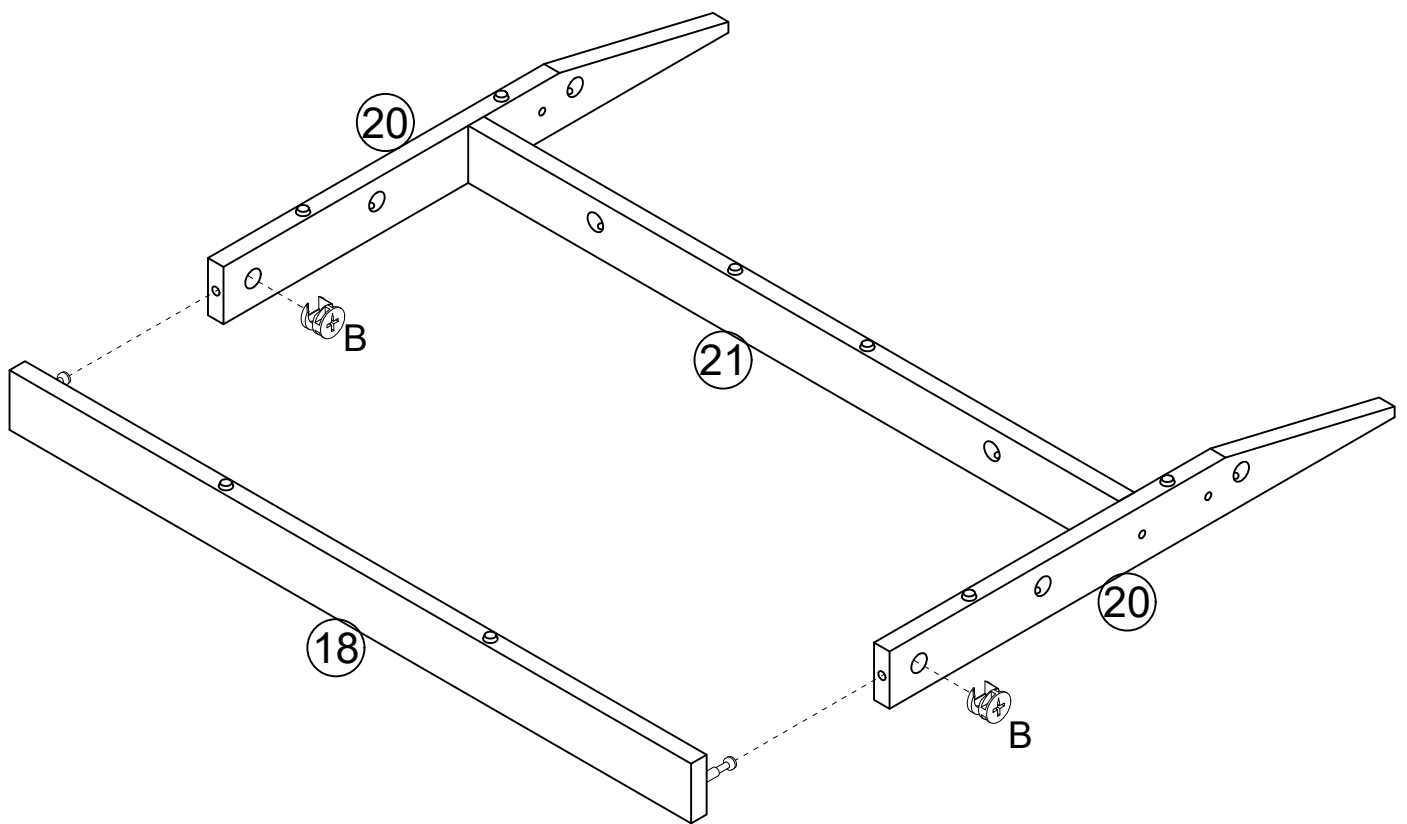
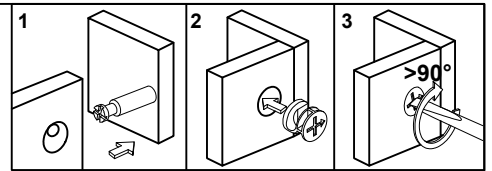

Attach Part #18 to Part #20 x2 with nuts B x2 as shown.
Then turn nuts B x2 to secure position.



15

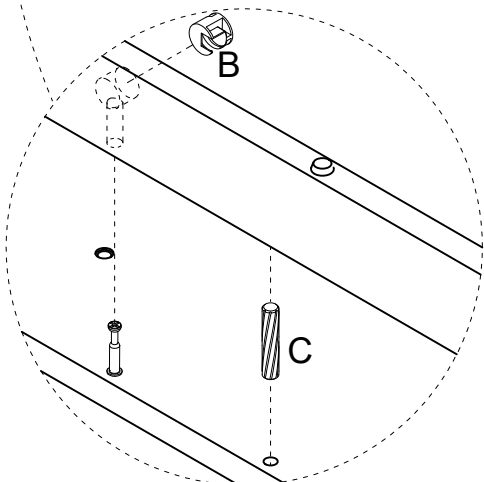
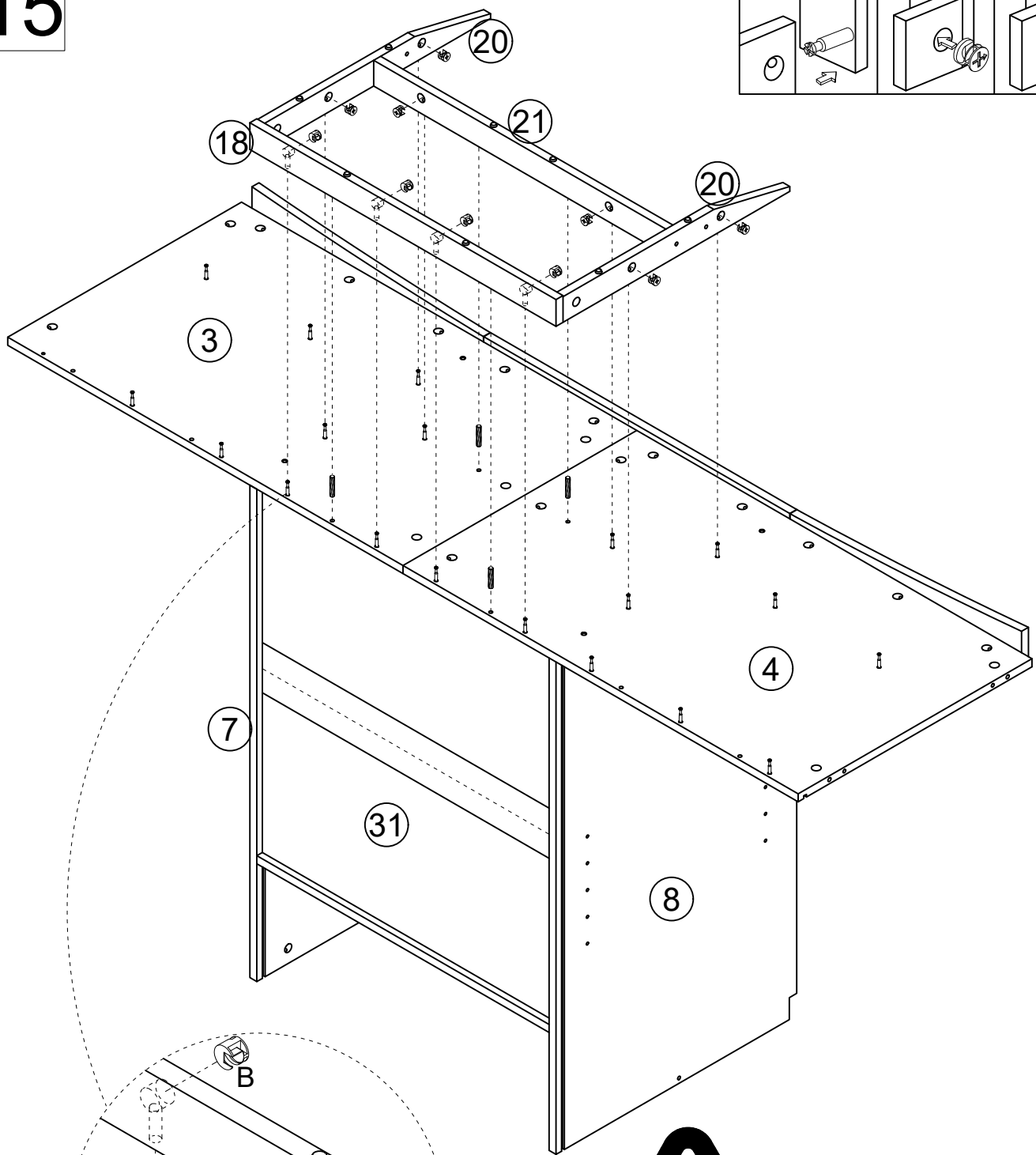
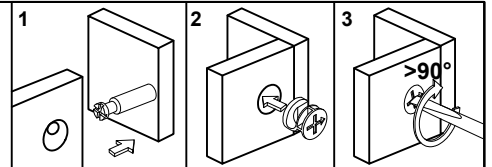

Attach the assembled unit to Part #3&4 with dowel C x4 and nuts B x10 as shown.
Then turn nuts B x10 to secure position.

	Bx10
	Cx4

16

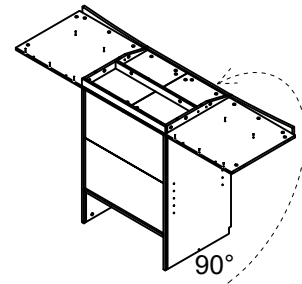
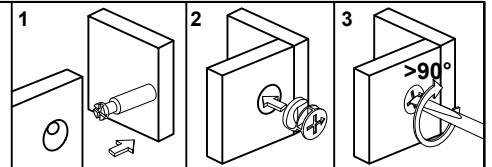
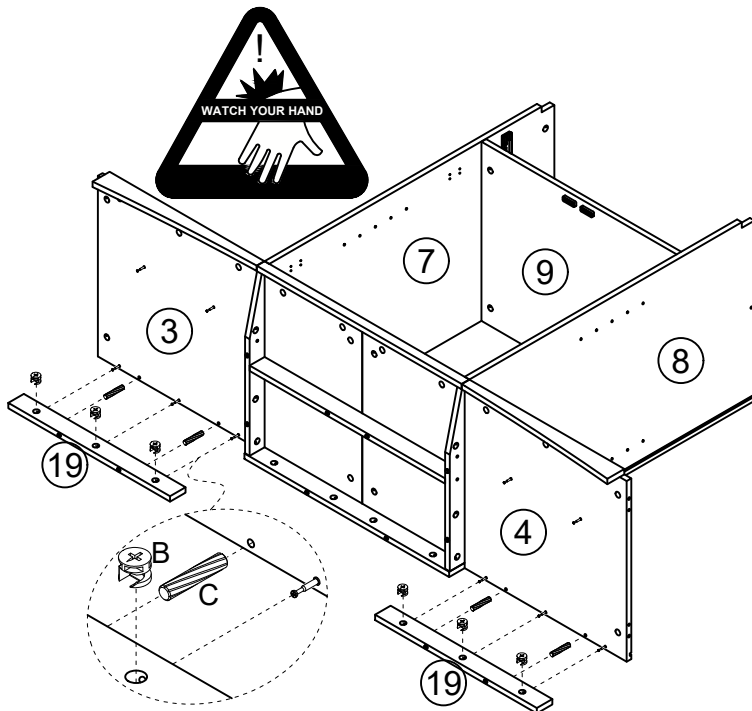

Turn the assembled unit 90° as shown.
Attach Part #19 x2 to Part #3&4 with dowel C x4 and nuts B x6 as shown.
Then turn nuts B x6 to secure position.
This step should be carried out by two adults.

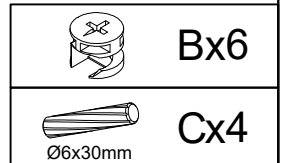
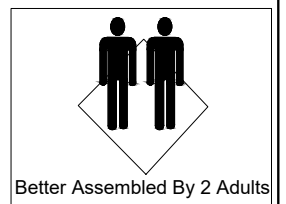

17

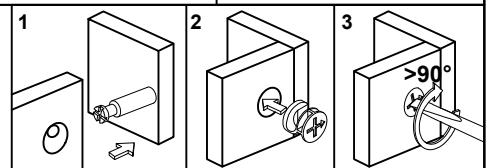
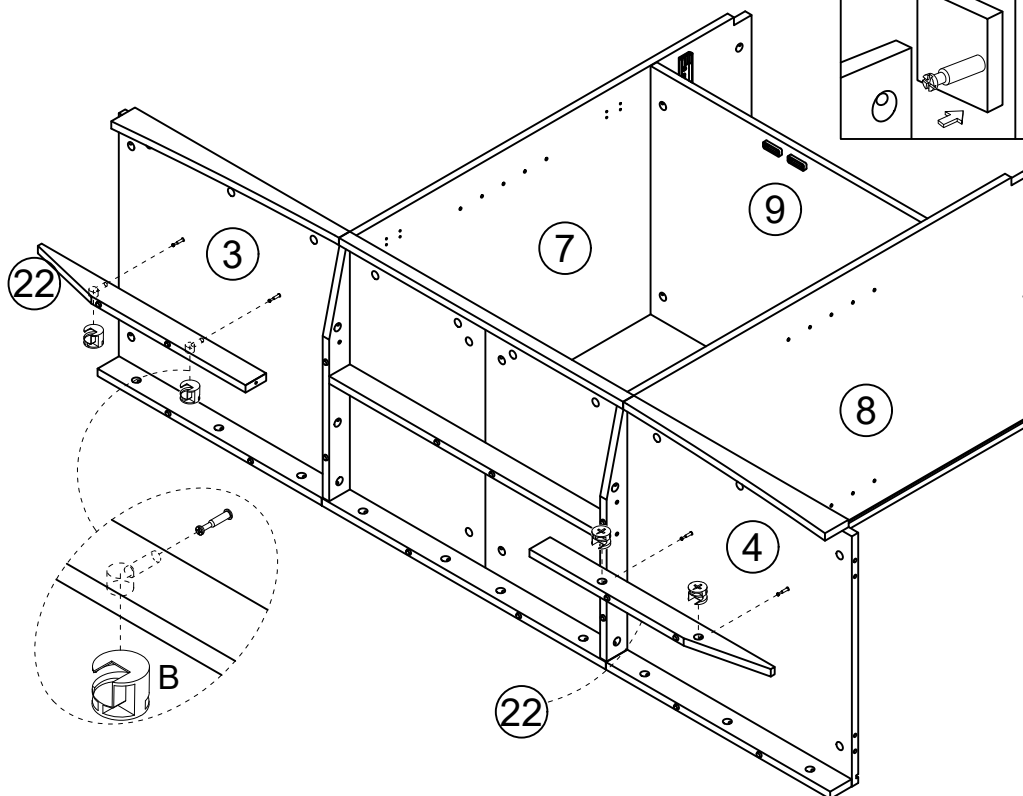

Attach Part #22 x2 to Part #3&4 with nuts B x4 as shown.
Then turn nuts B x4 to secure position.



18

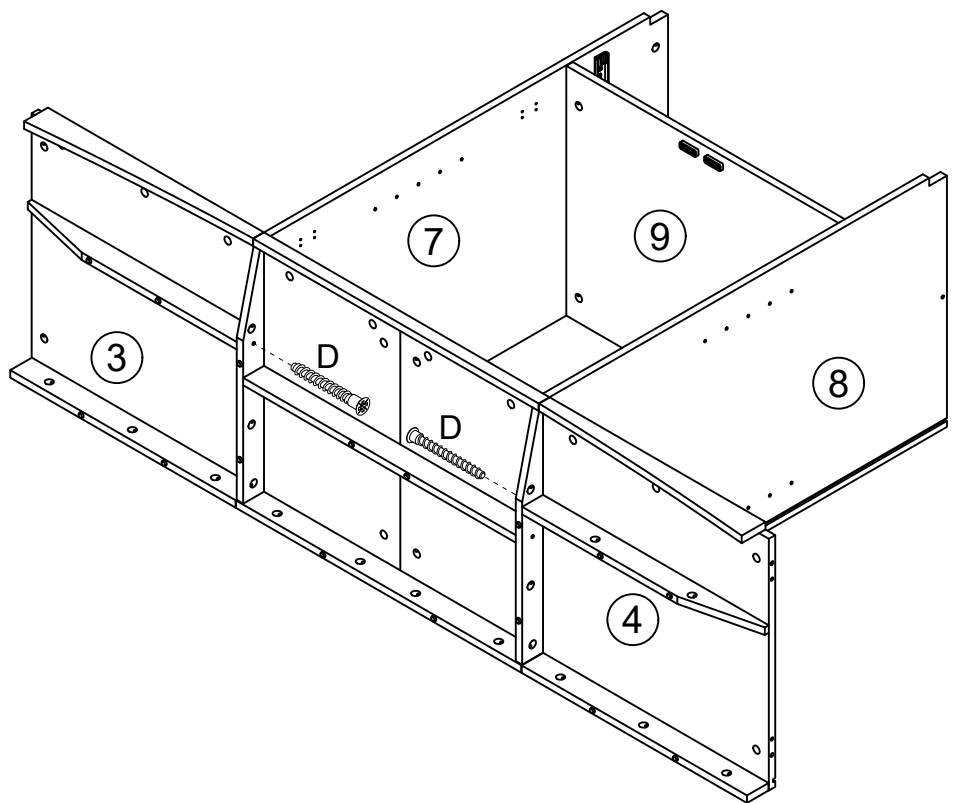

Secure Part #22 x2 with screws D x2 as shown.

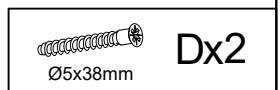

19

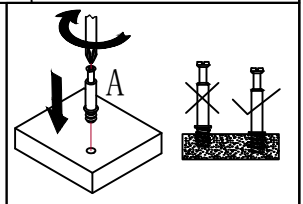
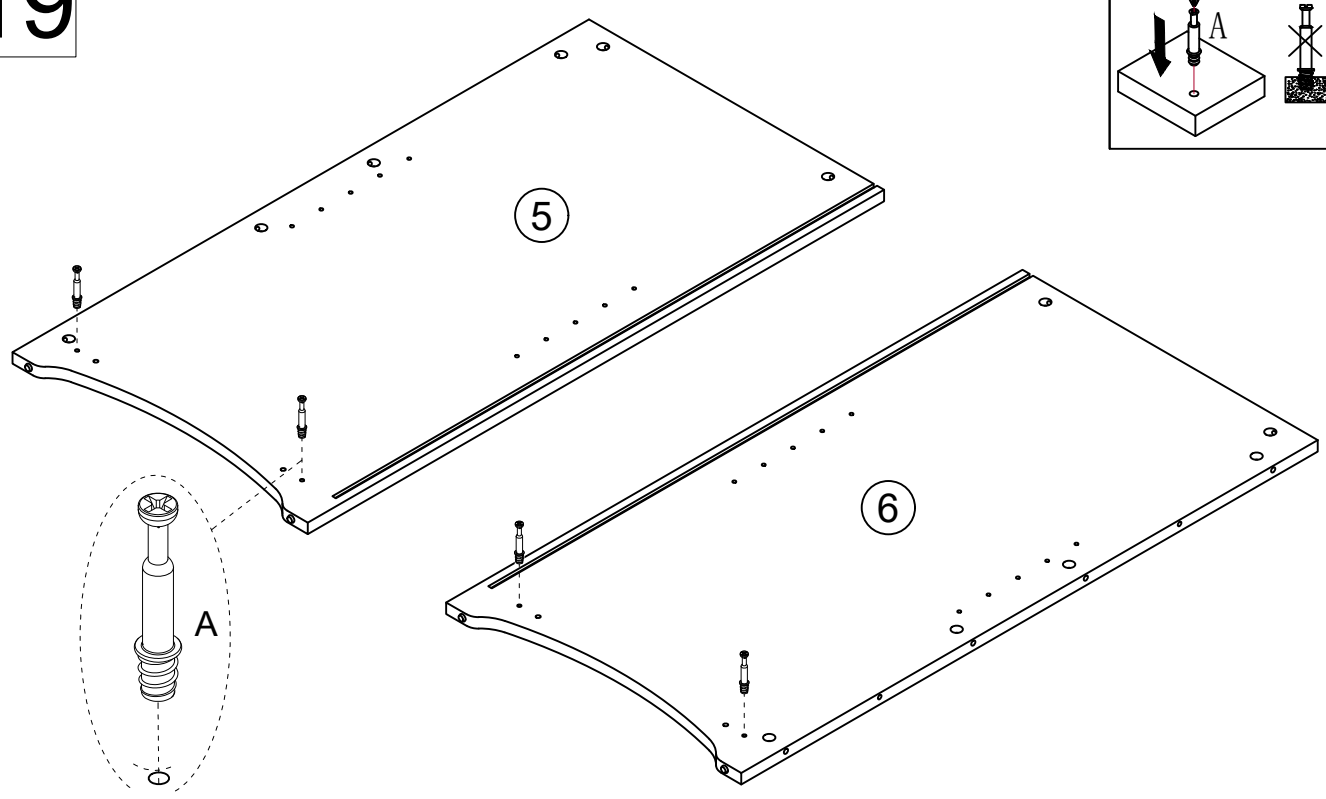

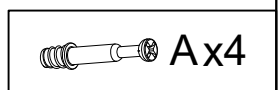

Install Cam Bolt A x4 to Part #5 and Part #6 as shown.

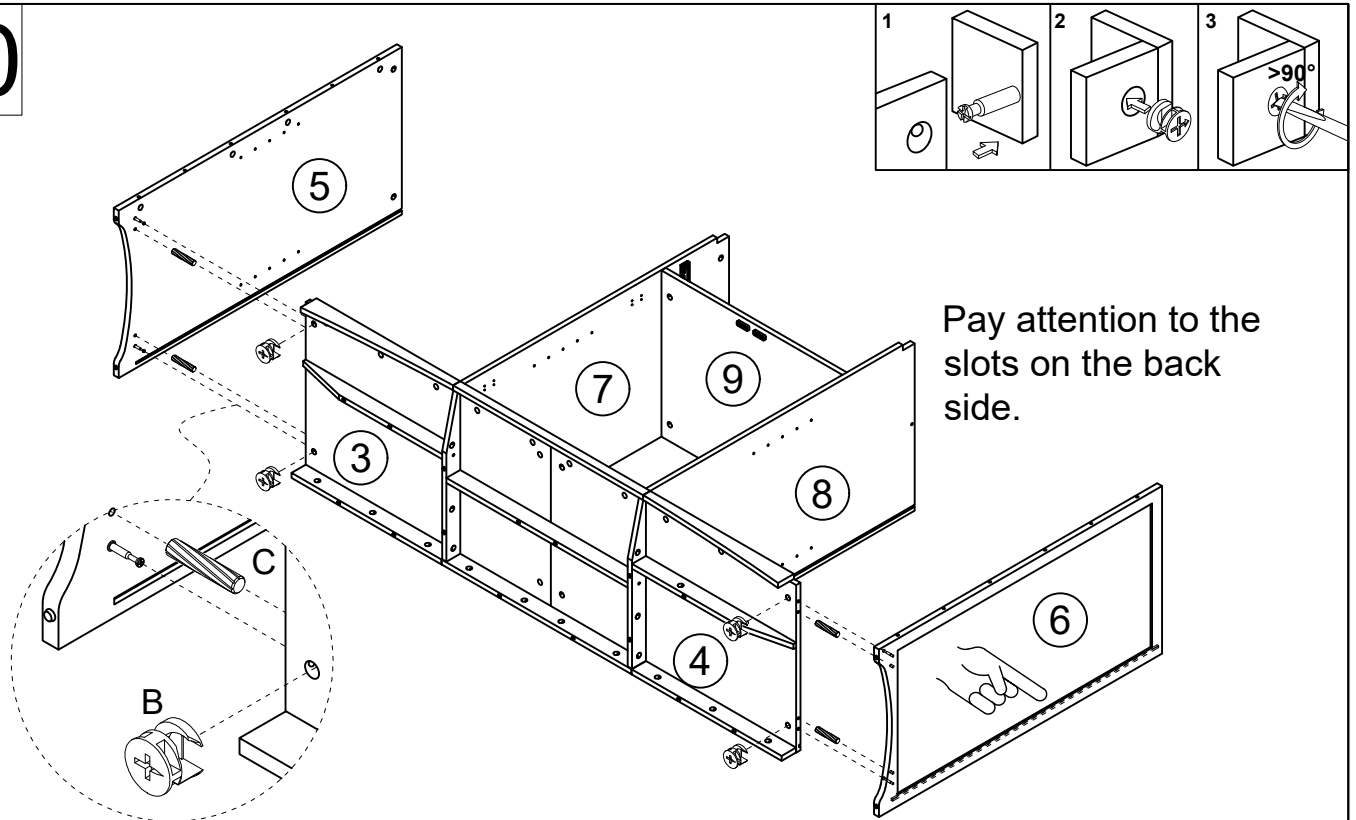

20



Attach Part #5&6 to Part #3&4 with dowel C x4 and nuts B x4 as shown.
Then turn nuts B x4 to secure position.

	Bx4
 Ø6x30mm	Cx4

21

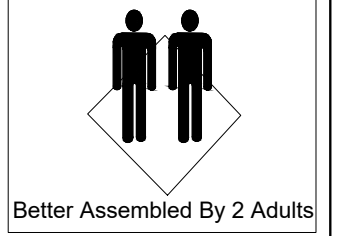
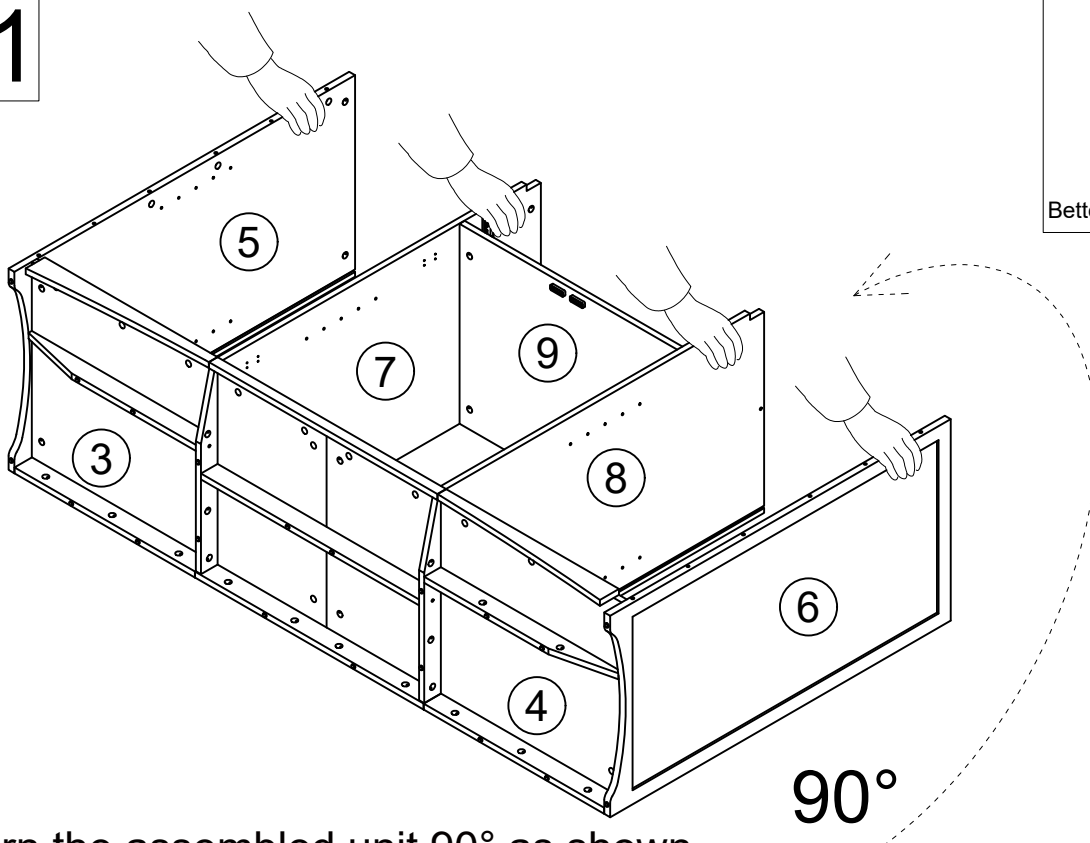

Turn the assembled unit 90° as shown.
When performing the flipping operation, make sure that the two people involved coordinate their movements and do it gently.

22

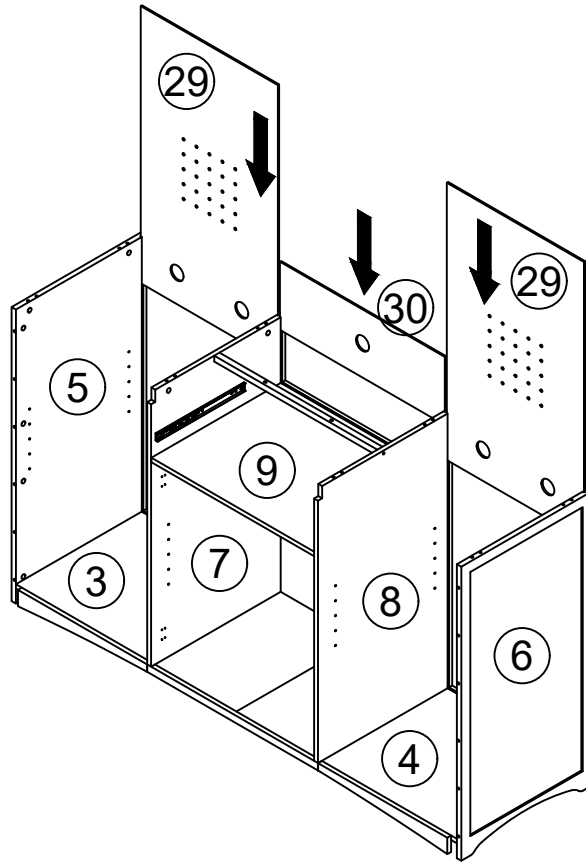

The thin plate needs to be fully inserted into the groove. If the insertion is not smooth, you can try pressing from the front or the back to make adjustments until the thin plate is fully inserted into the groove.

Insert Part #29 x2 and Part #30 into the grooves of the assembled unit as shown.

23

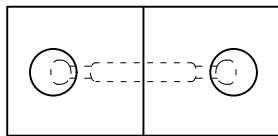

When inserting component **B**, the dimensions of the protruding parts on both sides of component **Q** should be kept consistent, and component **B** should be locked simultaneously.

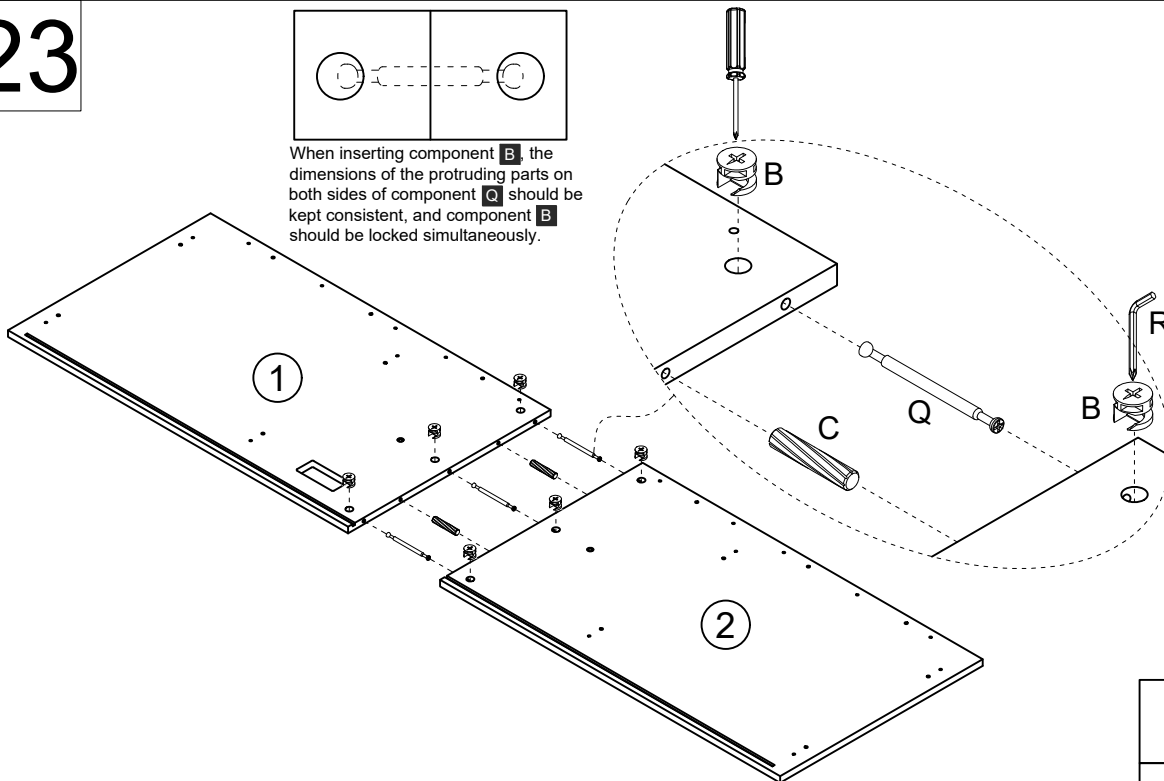

Connect Part #1 to Part #2 with Q x3, dowel C x2, and nuts B x6 as shown.

Then tighten the nuts B on both sides of each Q simultaneously using a screwdriver and tool R as shown.

	Bx6
	Cx2
	Qx3
	Rx1

24

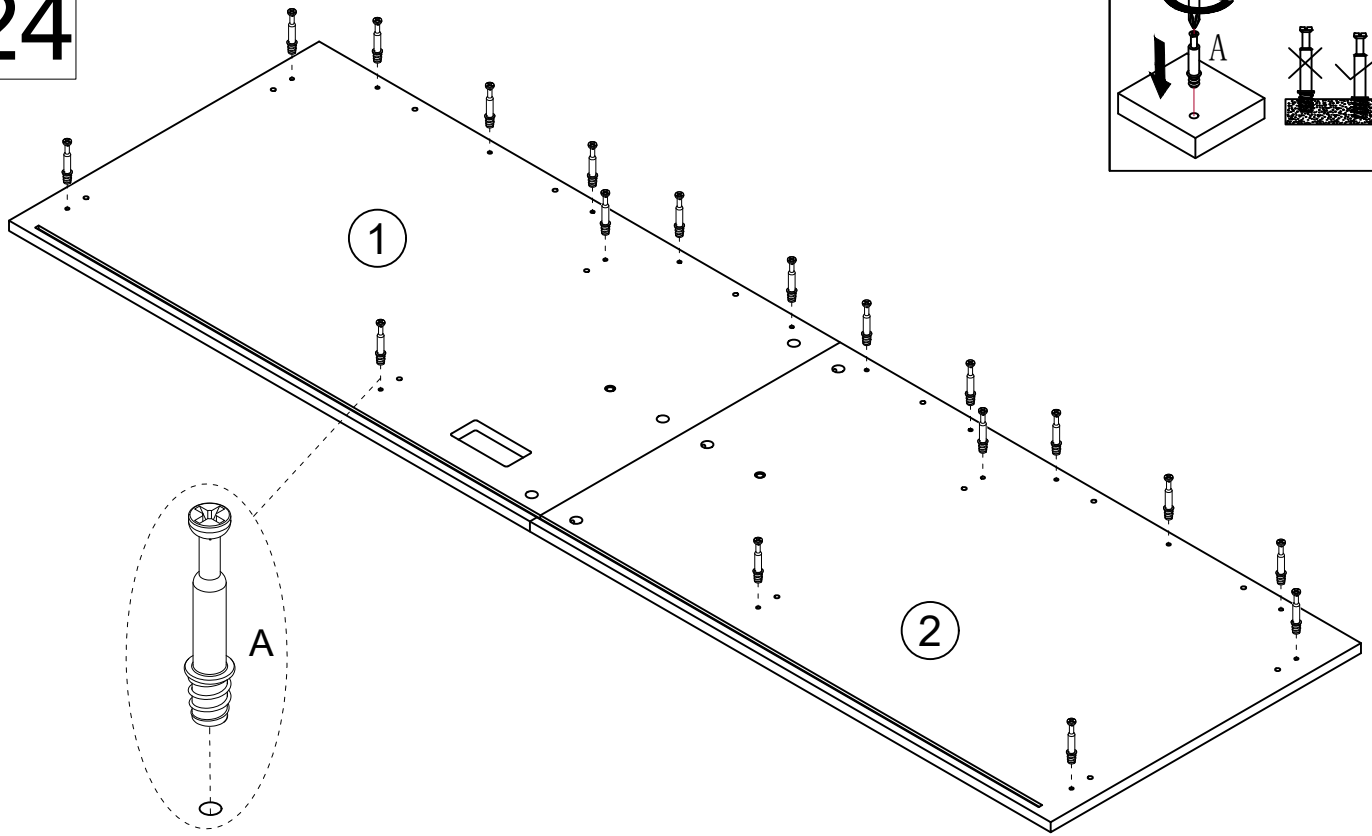

Install Cam Bolt A x18 to Part #1&2 as shown.



25

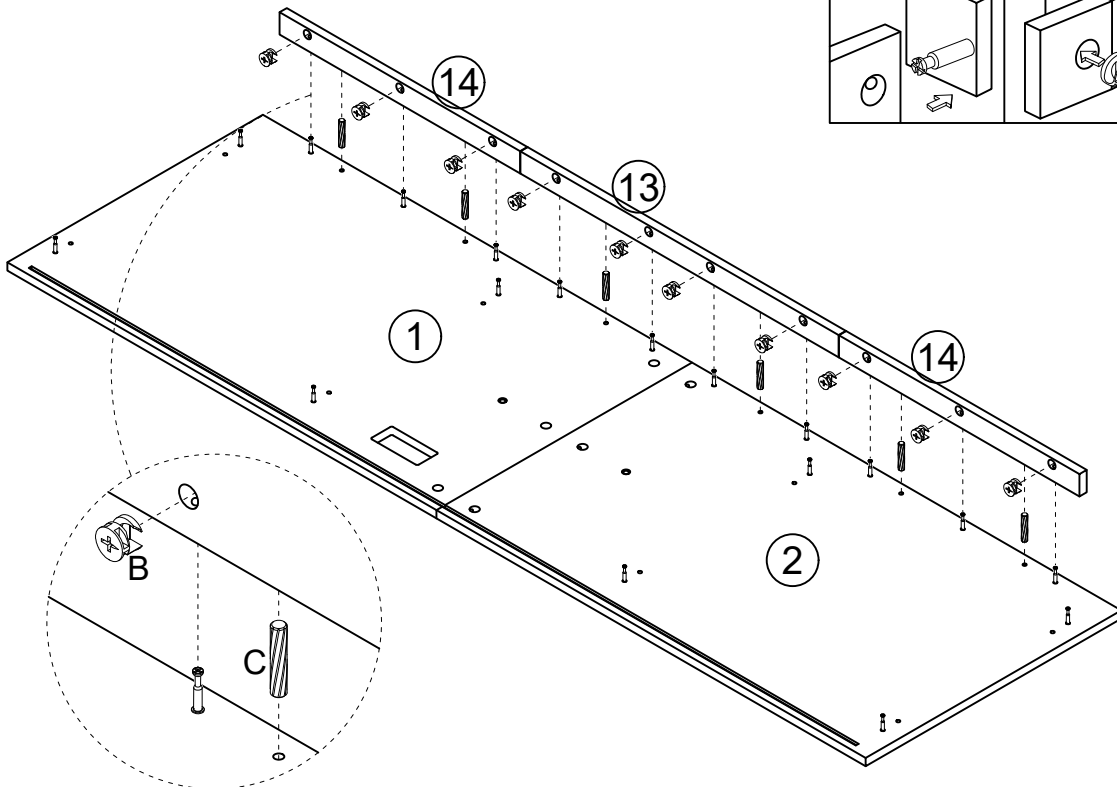

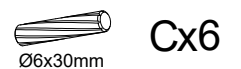

Attach Part #13 and Part #14 x2 to Part #1&2 with dowel C x6 and nuts B x10 as shown.
Then turn nuts B x10 to secure position.

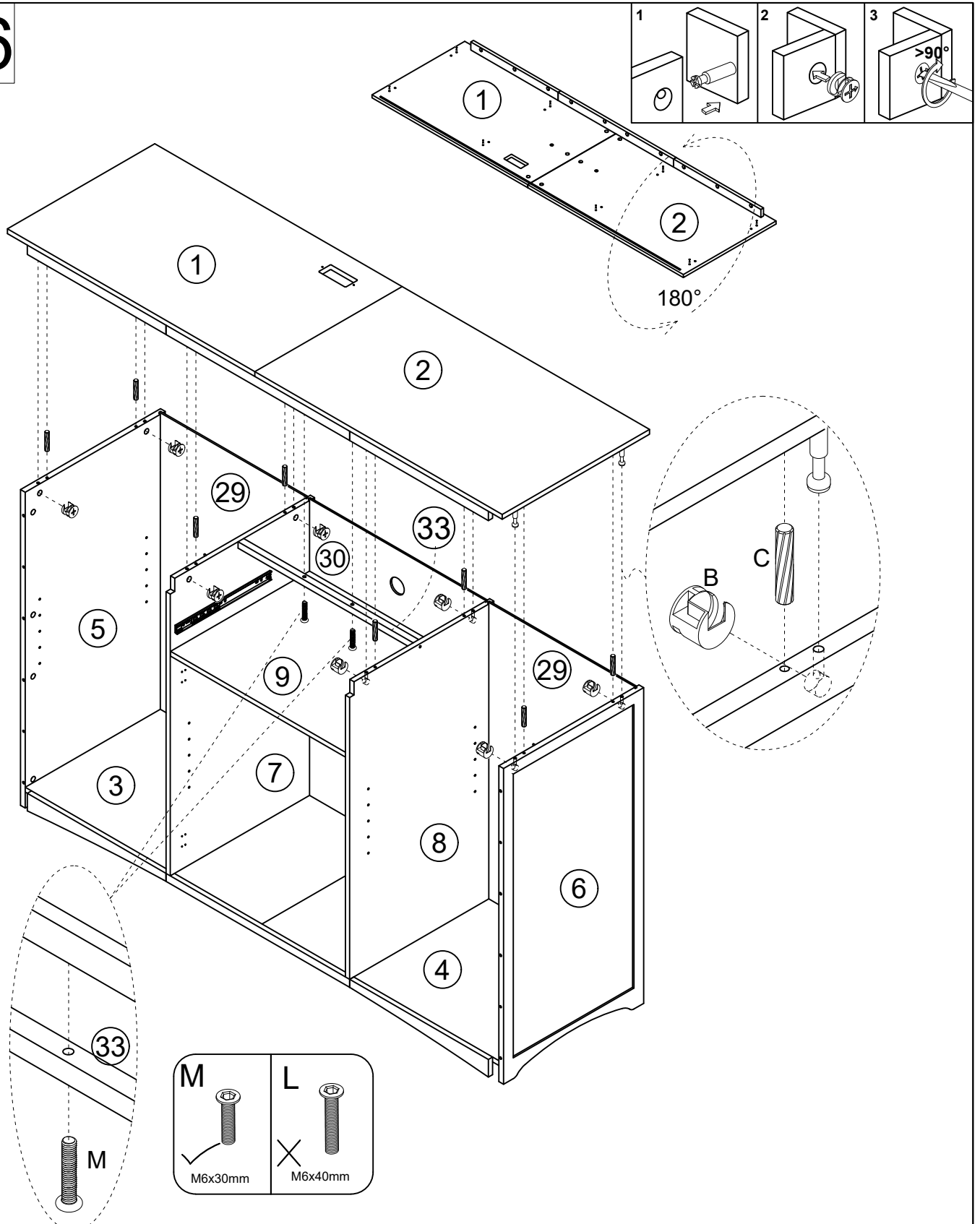

26

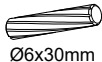

Turn Part #1&2 180° as shown.
 Attach Part #1&2 to the assembled unit from Step 22 with
 dowel C x8 and nuts B x8 as shown.
 Turn nuts B x8 to secure position.
 Then secure Part #33 to Part #1&2 with screws M x2 as
 shown.

	Bx8
 Ø6x30mm	Cx8
 M6x30mm	Mx2
 4mm	Rx1

27

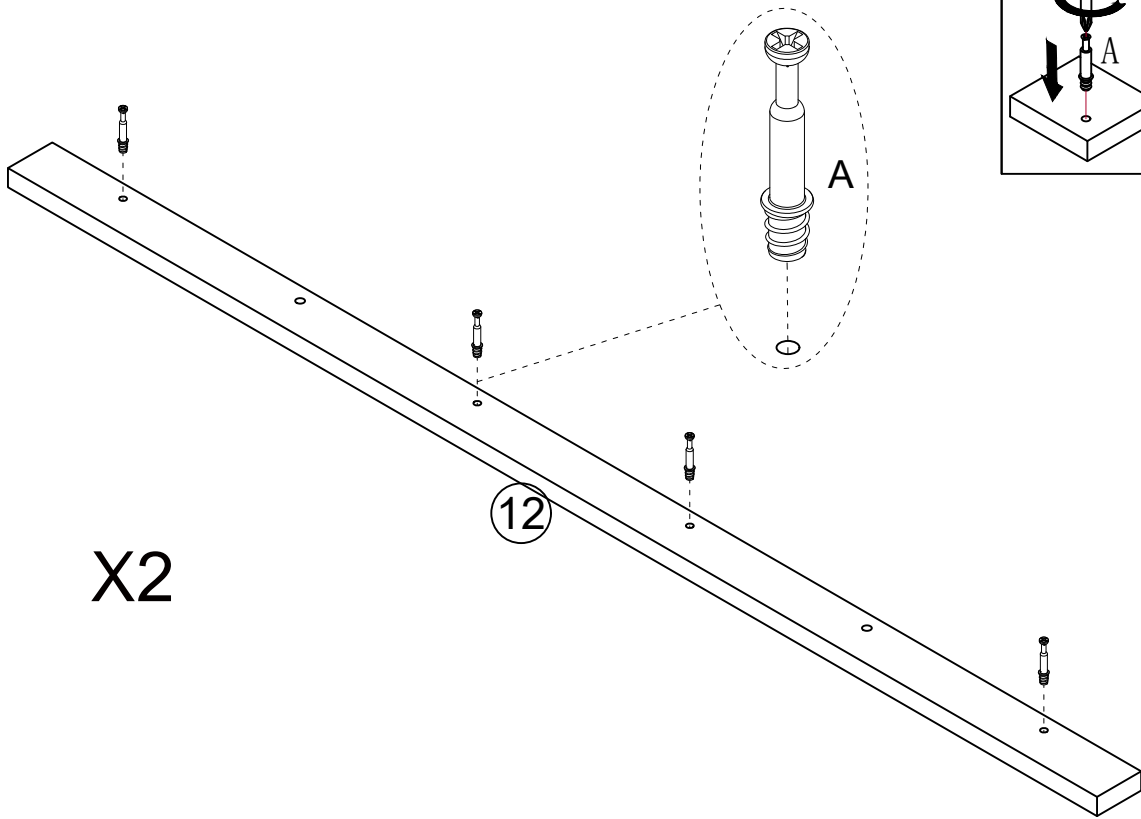

X2

Install Cam Bolt A x8 to Part #12 x2 as shown.

Ax8

28

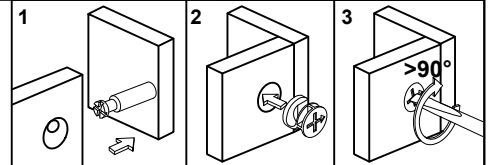
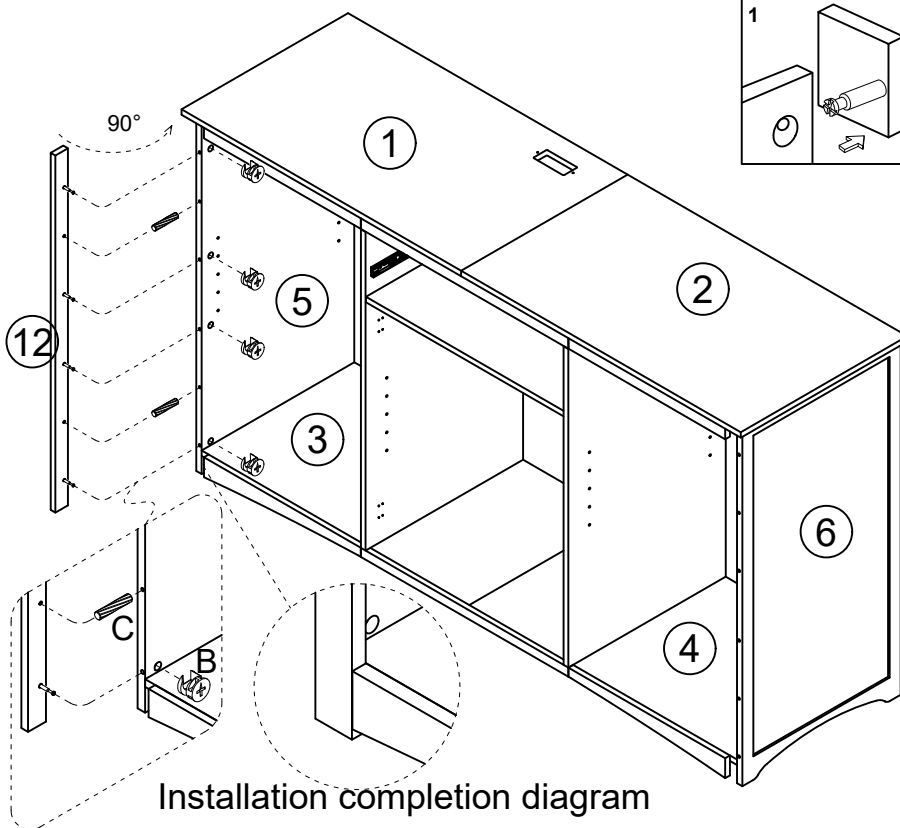

Attach Part #12 to Part #5 with dowel C x2 and nuts B x4 as shown.

Then turn nuts B x4 to secure position.

Bx4

Cx2
Ø6x30mm

29

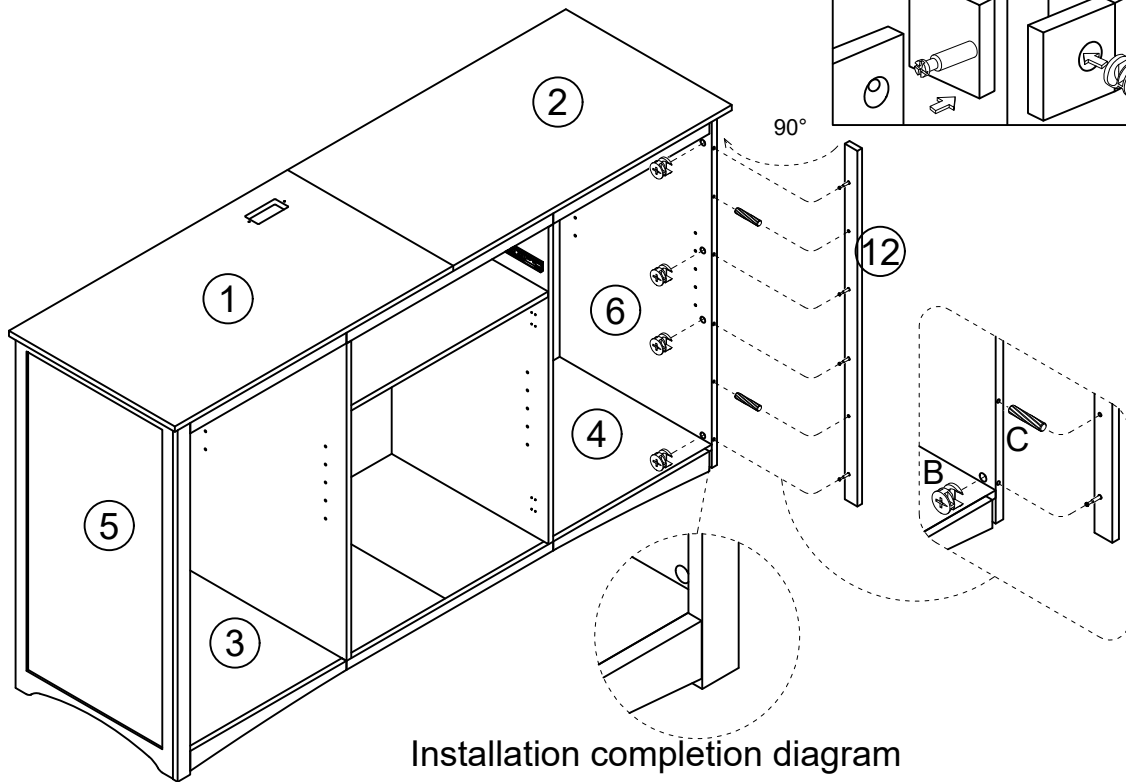

Installation completion diagram

Attach Part #12 to Part #6 with dowel C x2 and nuts B x4 as shown.
Then turn nuts B x4 to secure position.

	Bx4
	Cx2 Ø6x30mm

30

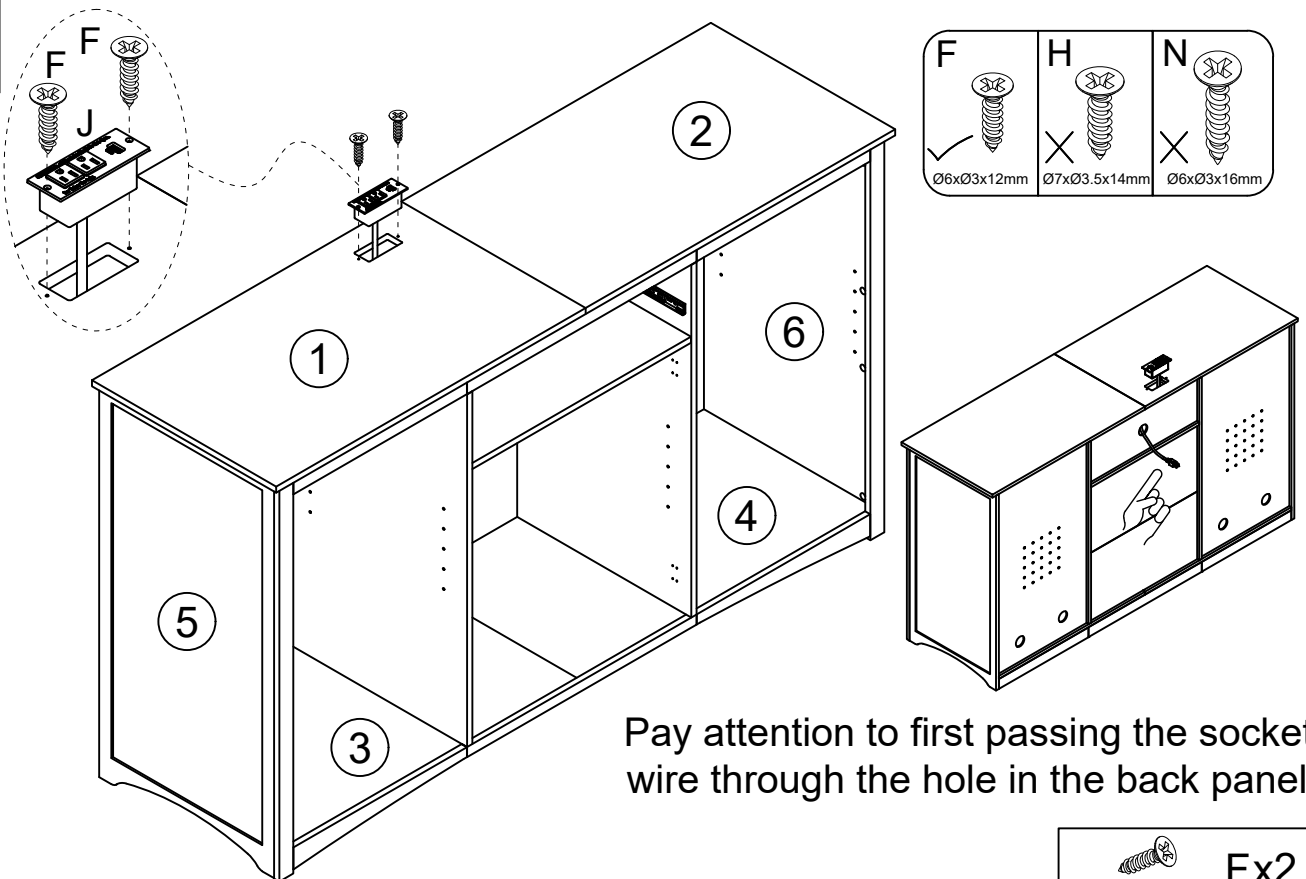

Pay attention to first passing the socket wire through the hole in the back panel.

Attach socket J to Part #1 with screws F x2 as shown.

	Fx2 Ø6xØ3x12mm
	Jx1

31

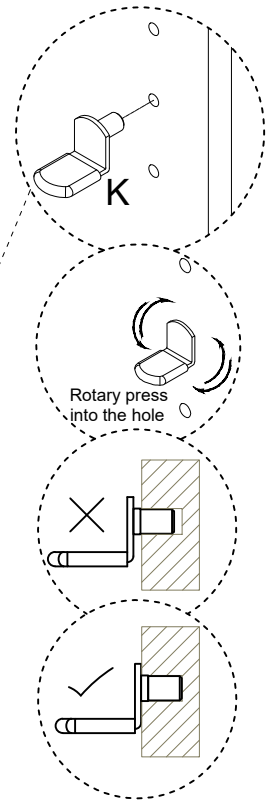
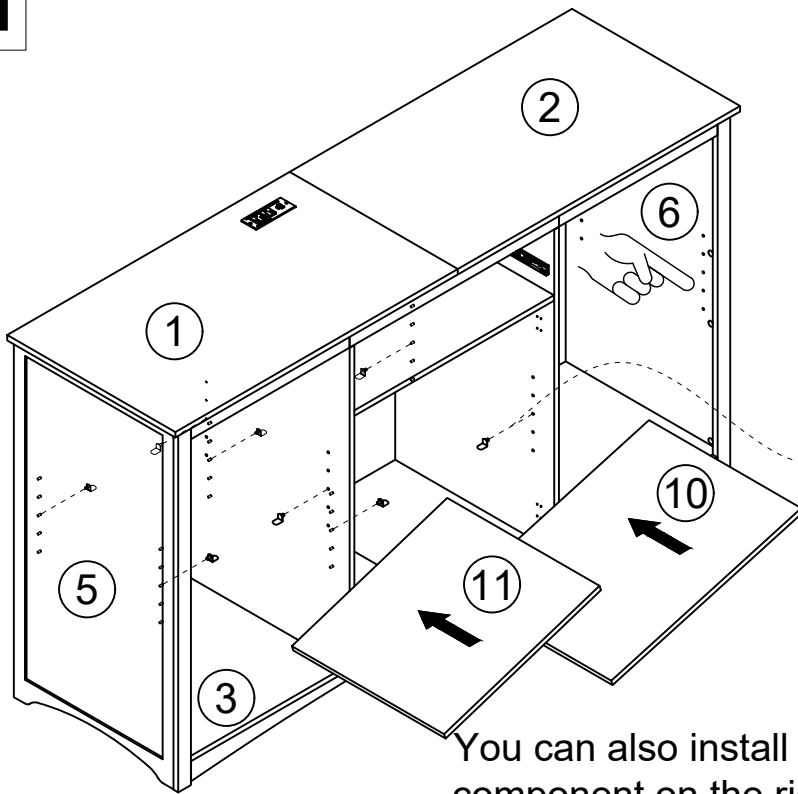

You can also install the No. (11) component on the right side.

Install K x8 to the assembled unit, then put Part #10 and Part #11 on K x8 as shown.



Kx8

32

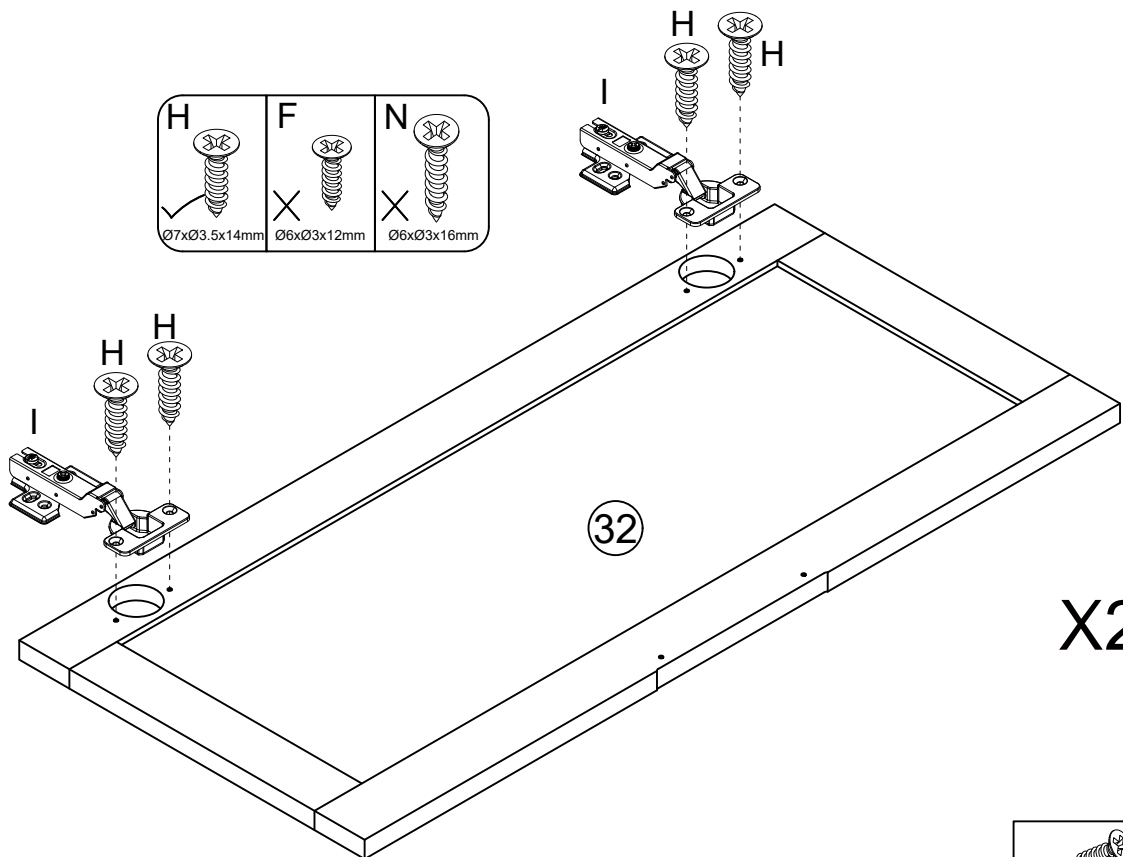

Attach hinge I x4 to Part #32 x2 with screws H x8 as shown.



Hx8

Ø7xØ3.5x14mm



I x4

33

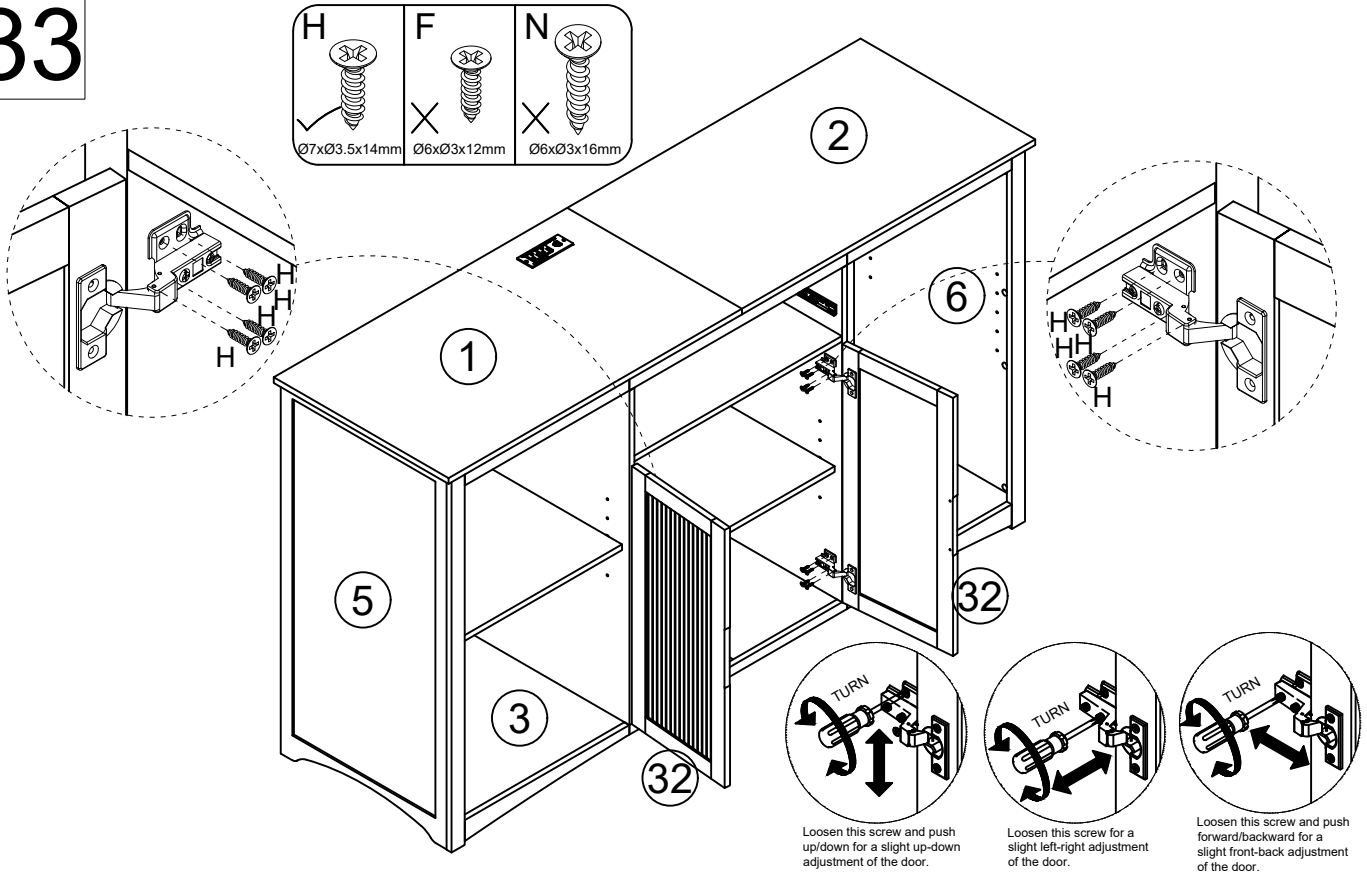

Attach Part #32 x2 to the assembled unit with screws H x16 as shown.



34

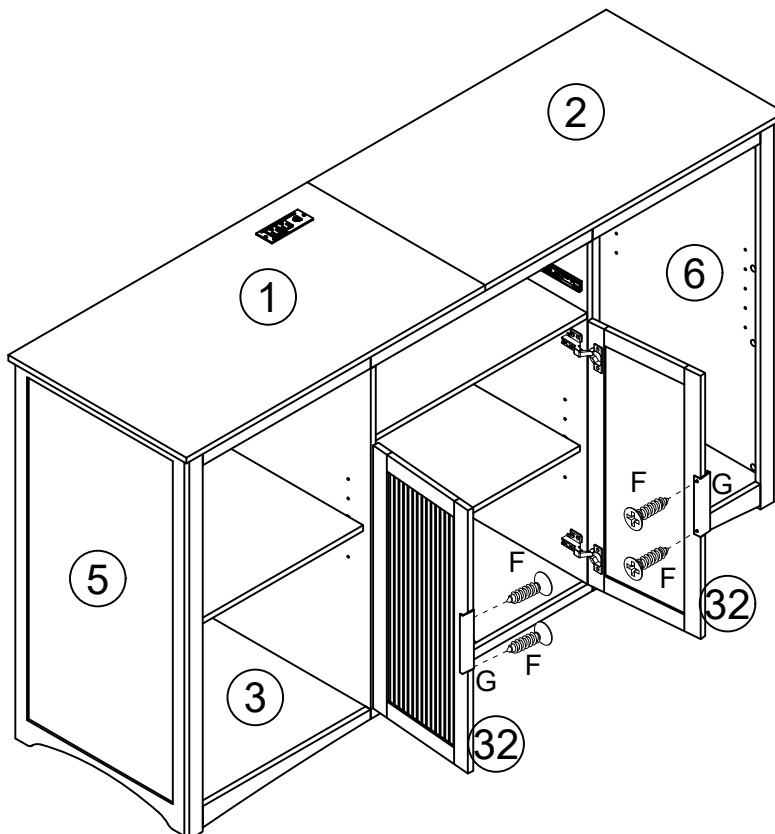

Install handle G x2 to Part #32 x2 with screws F x4 as shown.

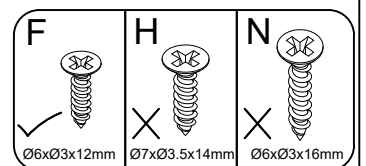

35

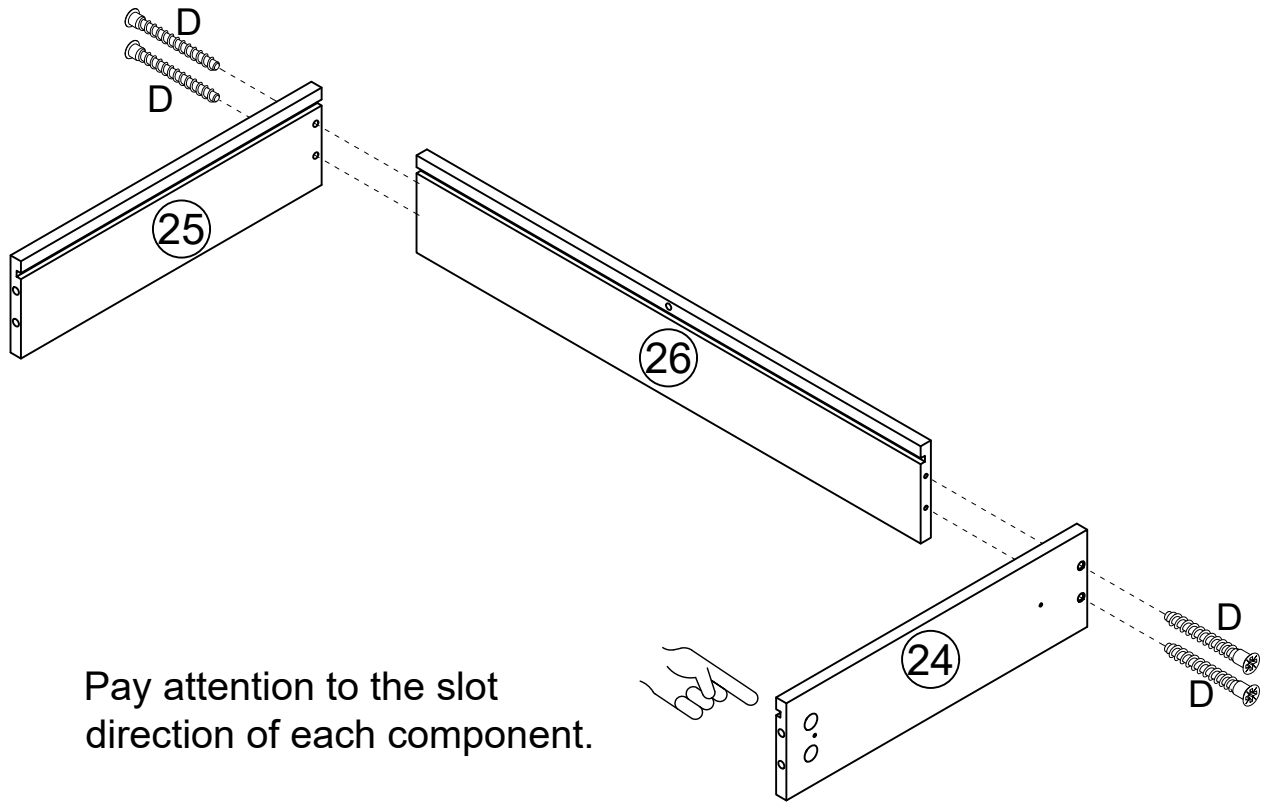

Attach Part #24 and Part #25 to Part #26 with screws D x4 as shown.



36

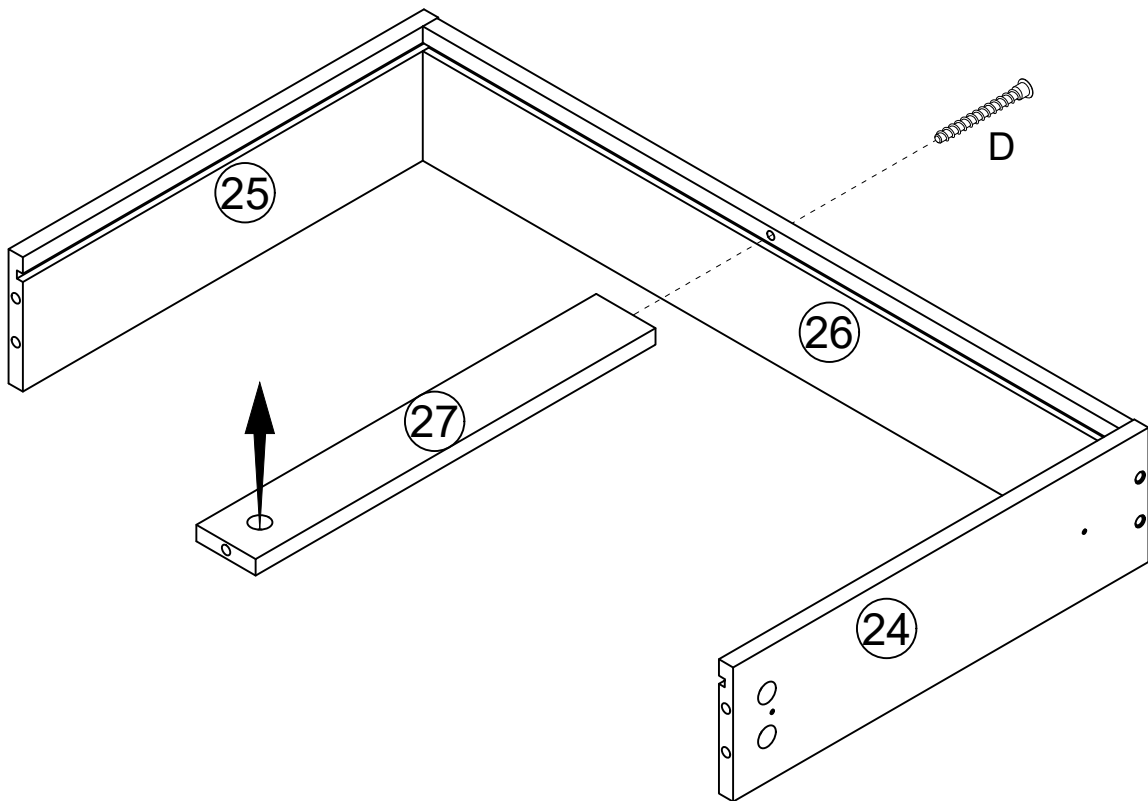

37

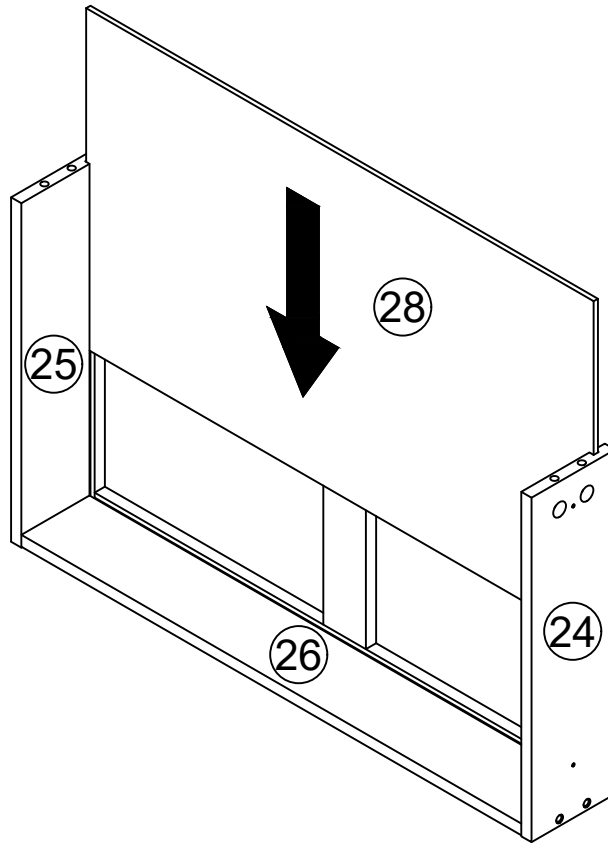

The thin plate needs to be fully inserted into the groove. If the insertion is not smooth, you can try pressing from the front or the back to make adjustments until the thin plate is fully inserted into the groove.

Insert Part #28 into the grooves of the assembled unit as shown.

38

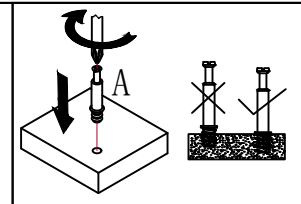
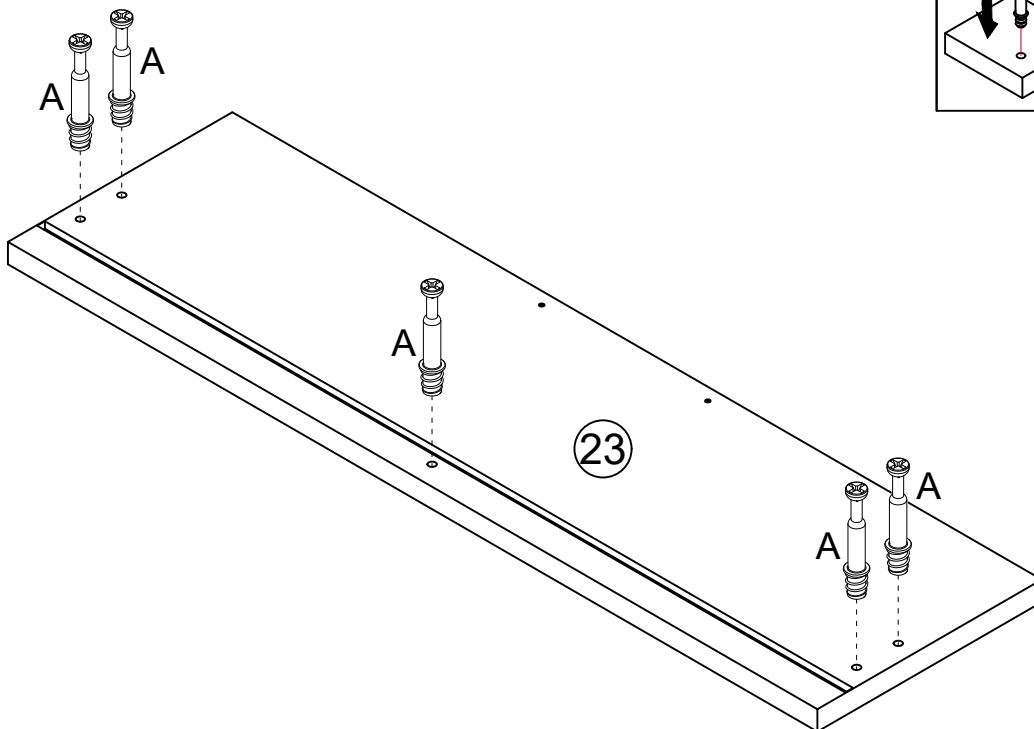

Install Cam Bolt A x5 to Part #23 as shown.



39

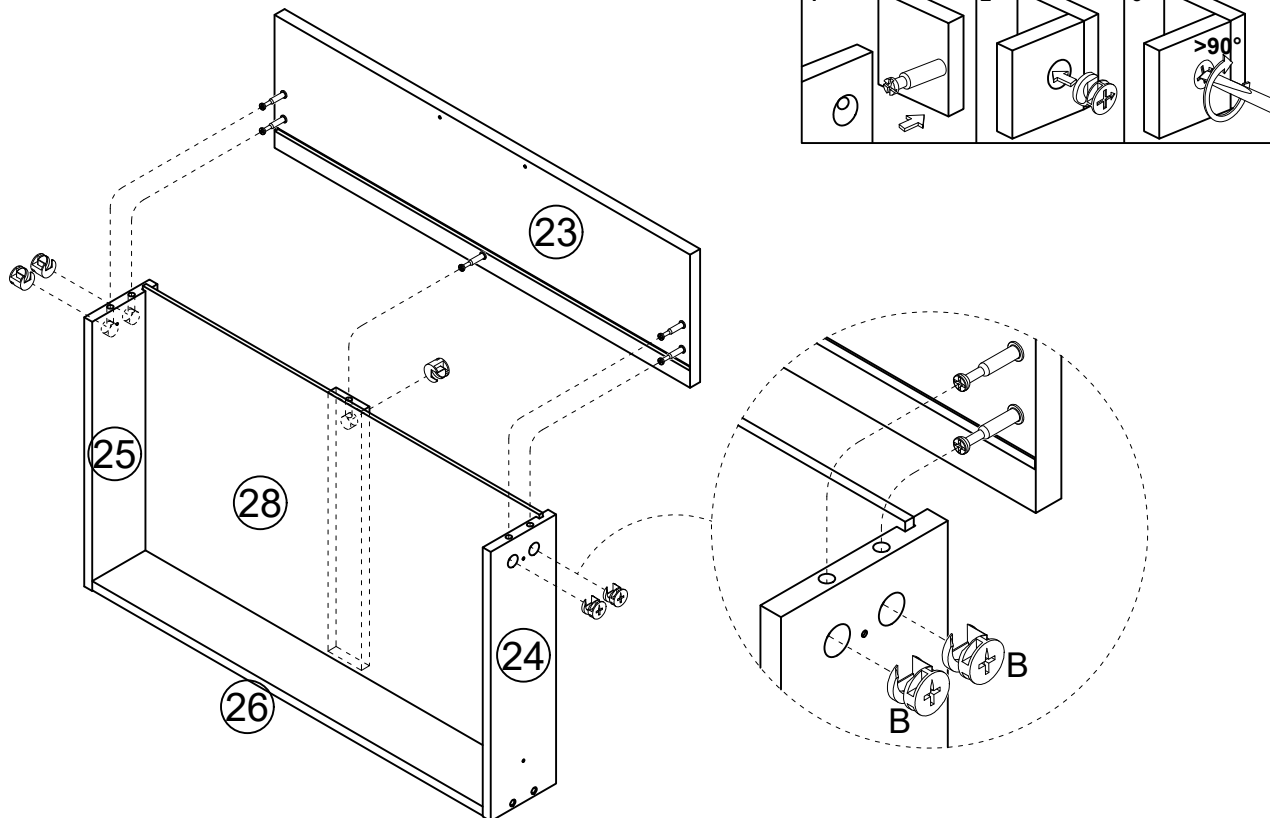

Attach Part #23 to the assembled unit from Step 37 with nuts B x5 as shown.
Then turn nuts B x5 to secure position.



Bx5

40

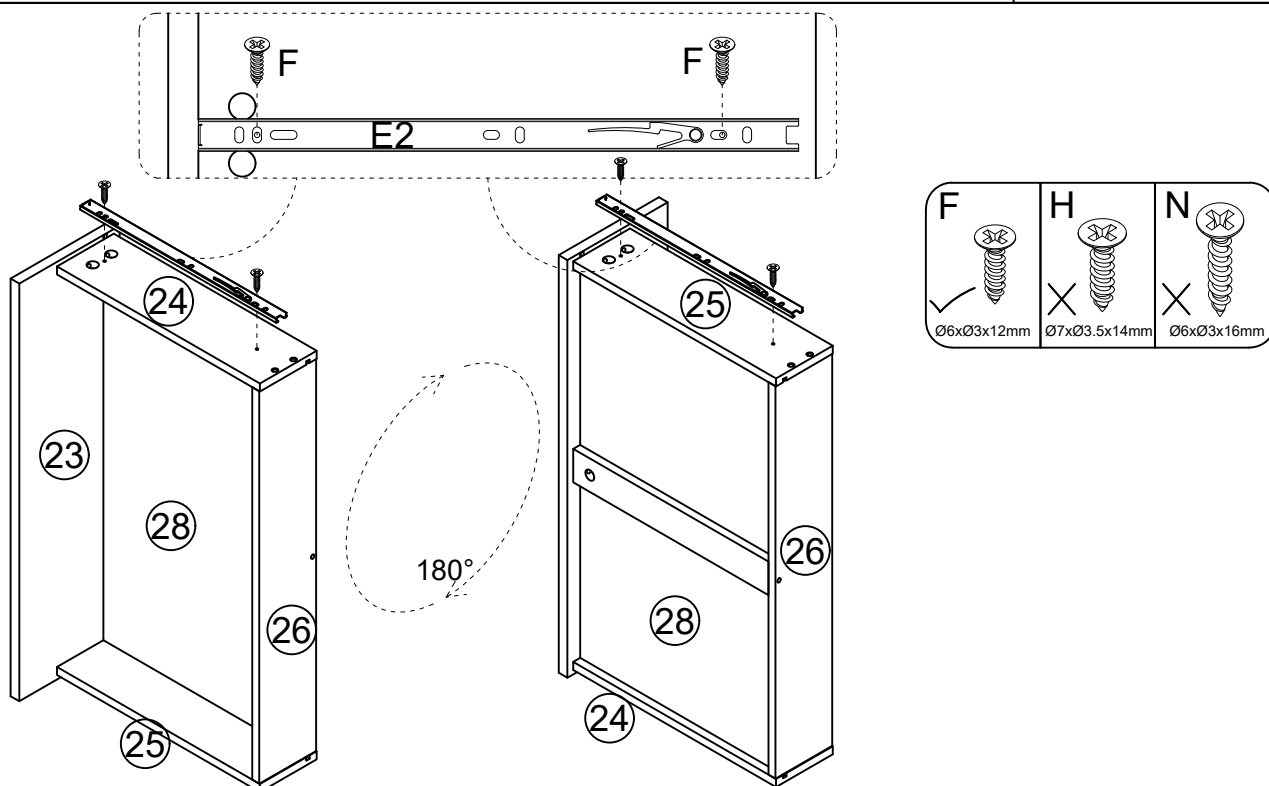

Attach the inner rail E2 to Part #24 with screws F x2 as shown.
Then turn the drawer 180° as shown.
Attach the inner rail E2 to Part #25 with screws F x2 as shown.

E2x2



Fx4

41

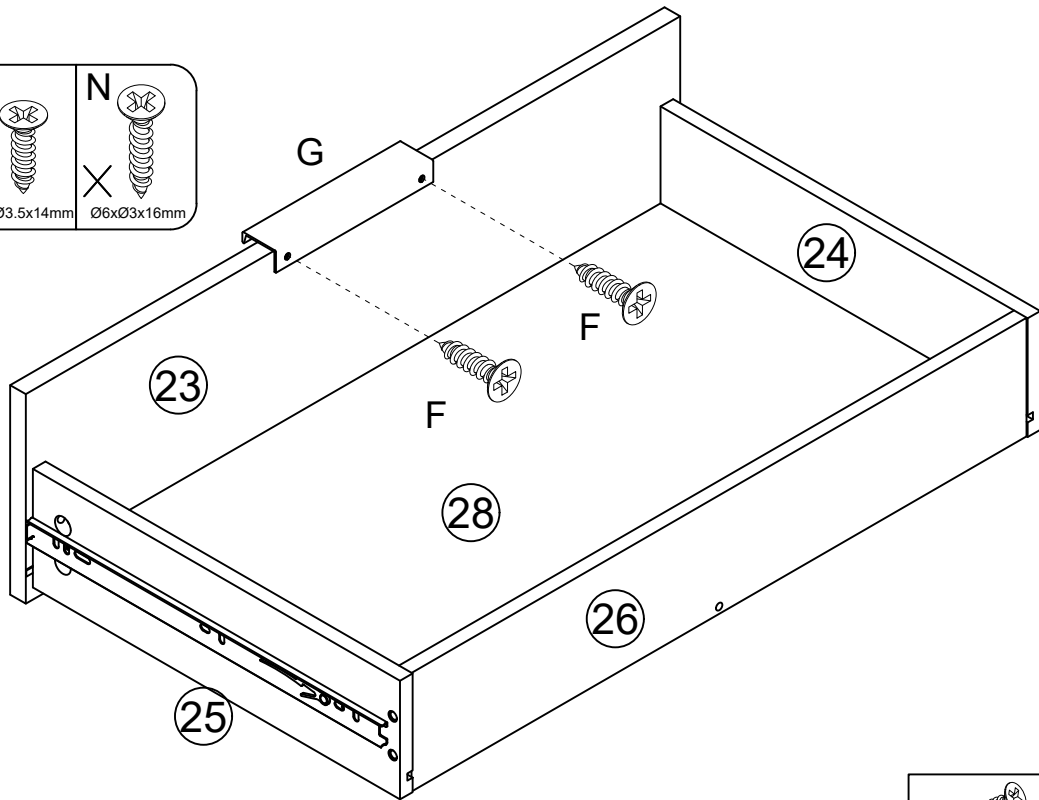
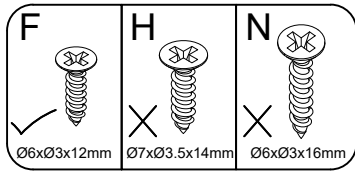

Install handle G to Part #23 with screws F x2 as shown.



F x2



G x1

42

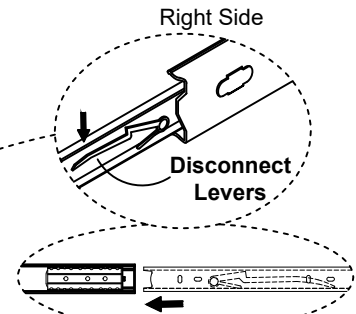
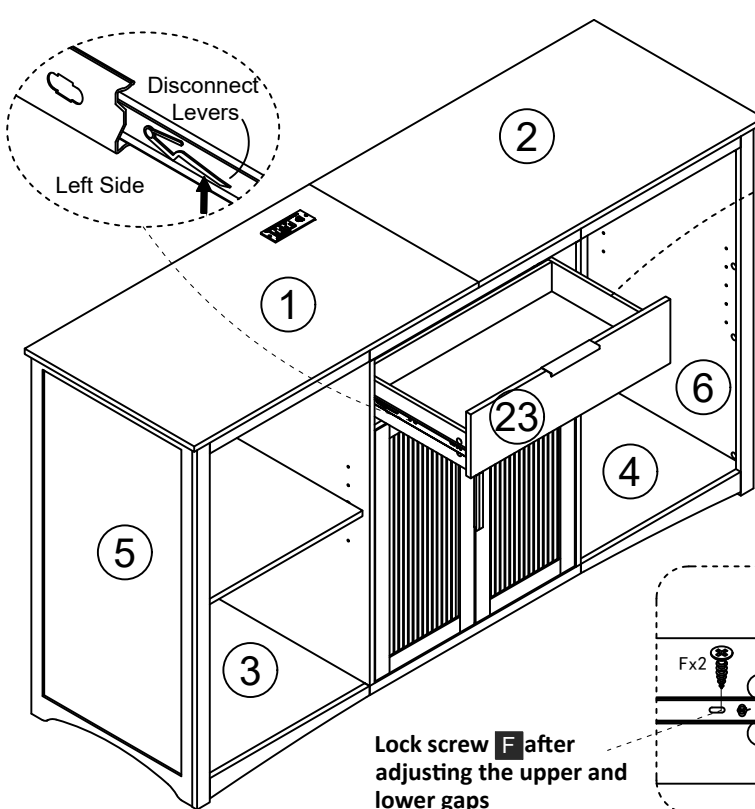

When installing the slide rail, it should be inserted at the same time, and then pushed together. If you have trouble pushing the drawer forward, pull back and push again

This screw can be loosened to adjust the top and bottom gaps of the drawer

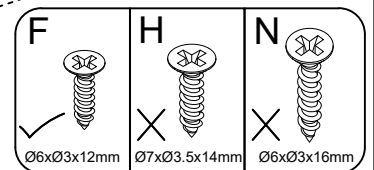

Insert the inner rail E2 x2 into the outer rail E1 x2 as shown. After adjusting the upper and lower gaps, lock screws F x2 onto the inner rail E2 x2 as shown.



F x2

43

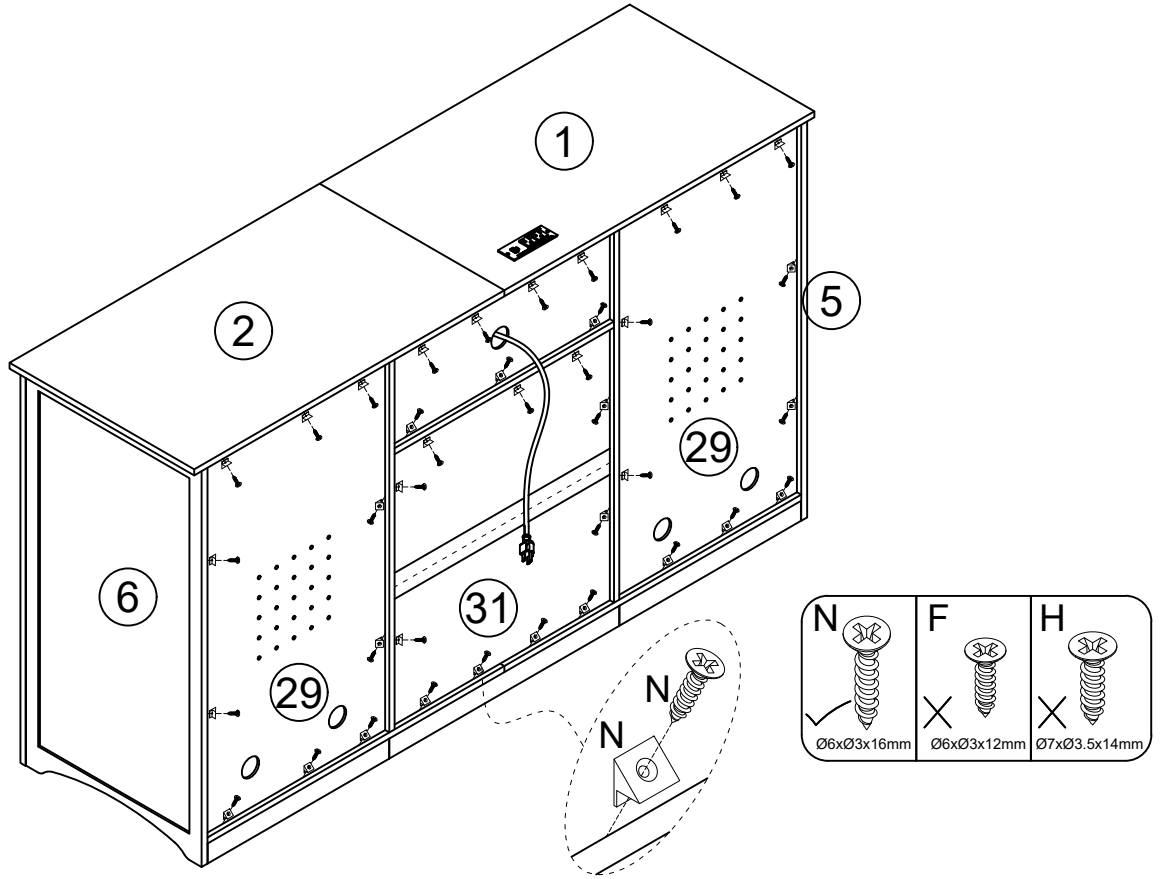

Install N x38 to the assembled unit as shown.



44

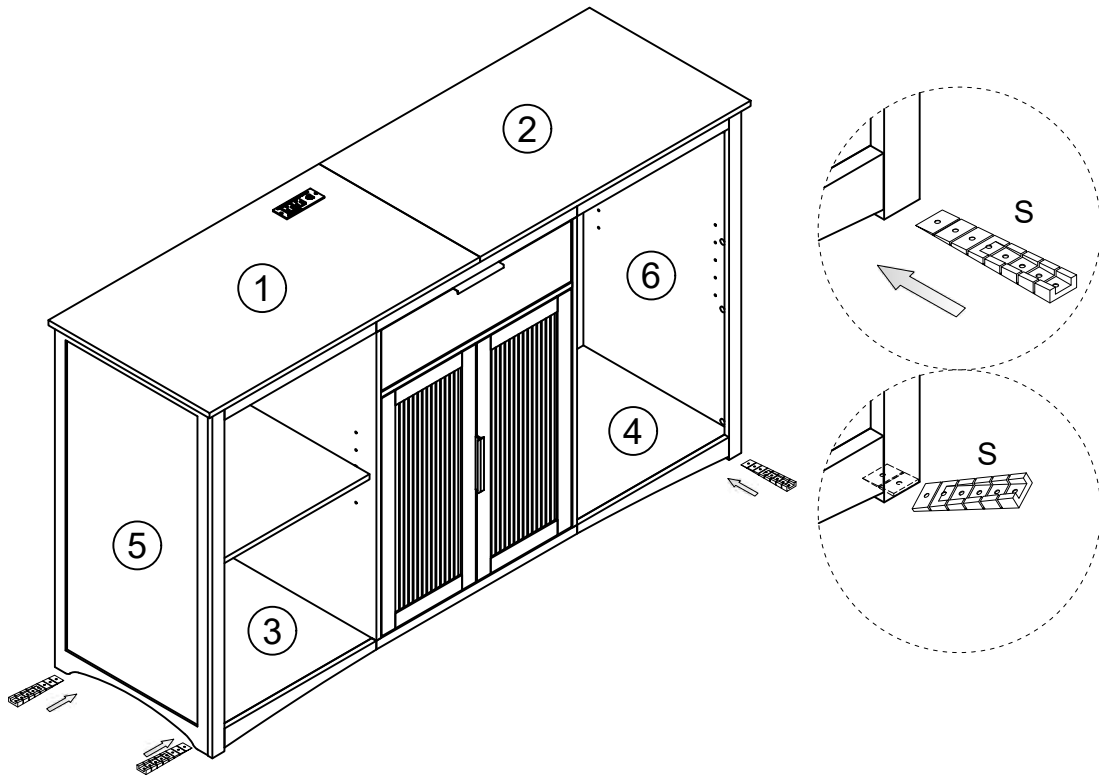

(Optional)

Install spacer S x6 to the assembled unit as shown if needed.

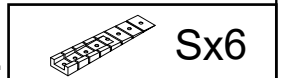

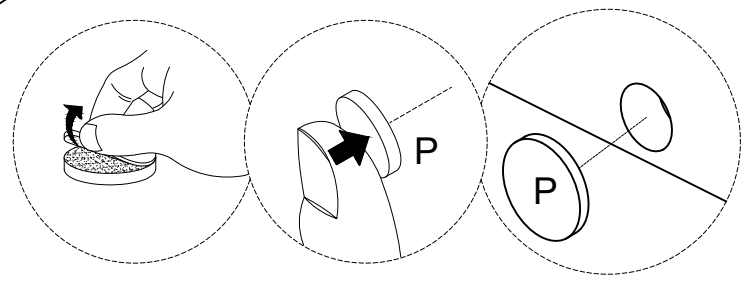
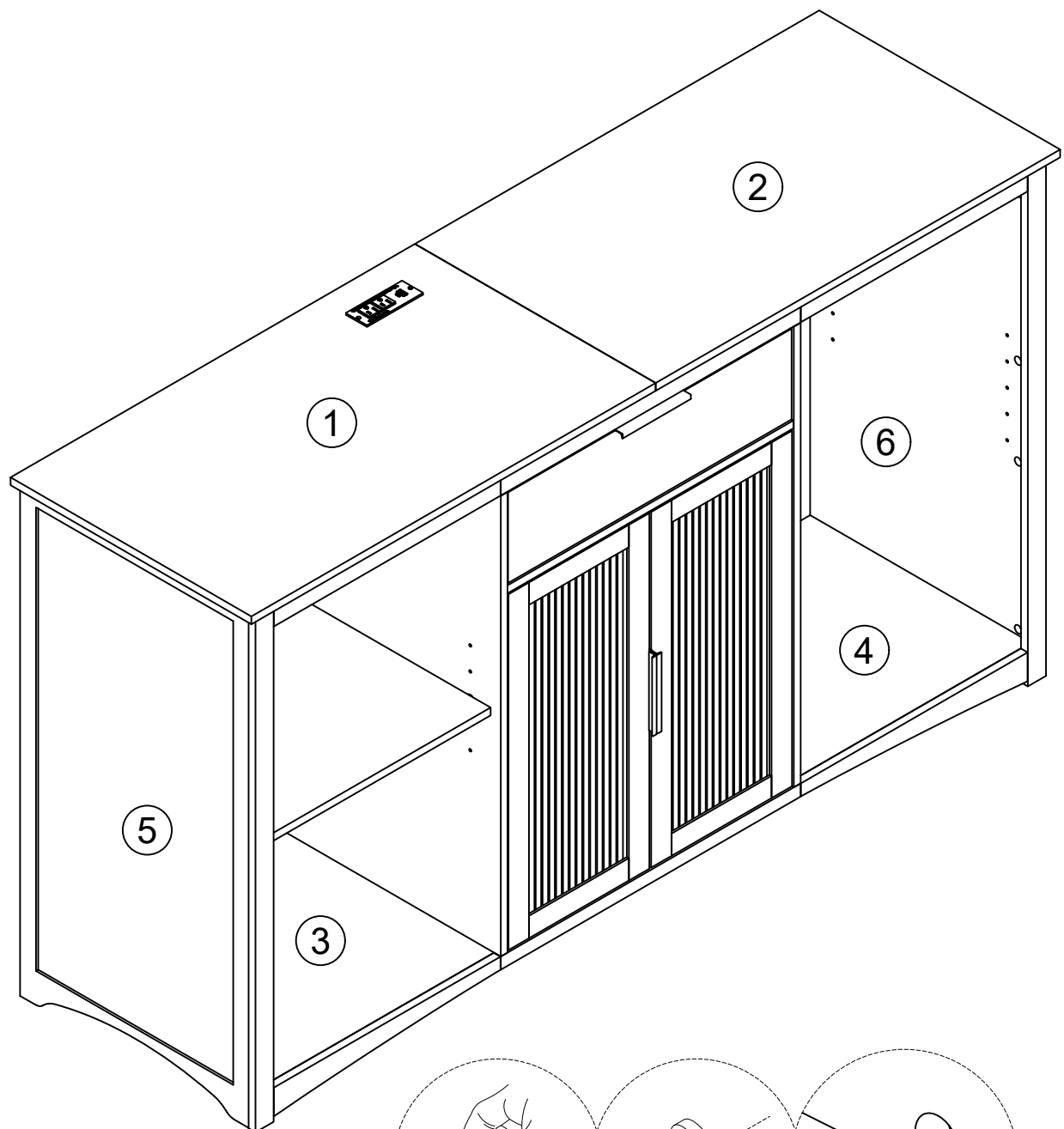

We provide round stickers P x36. You can stick it to cover the exposed nuts or holes so as to look nicer.

