

Montageanweisung / Installation instructions / Instruction de montage / Istruzioni di montaggio
 montagehandleiding / Instrukcja montażu / Montaj talimatlar / Osszeszerelési útmutató / Návod k montáži /
 Návod na montáž / Instrucțiune de montaj / Инструкция по монтажу / Montaj talimatina / Monteringsanvisningar
 Upute za montažu / Instrucciones de Montaje / Navodila za montažo

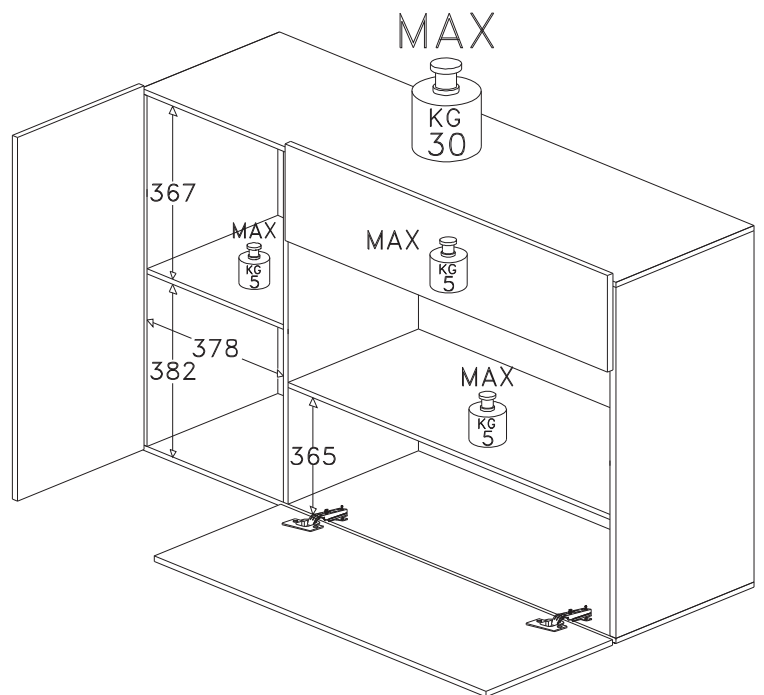
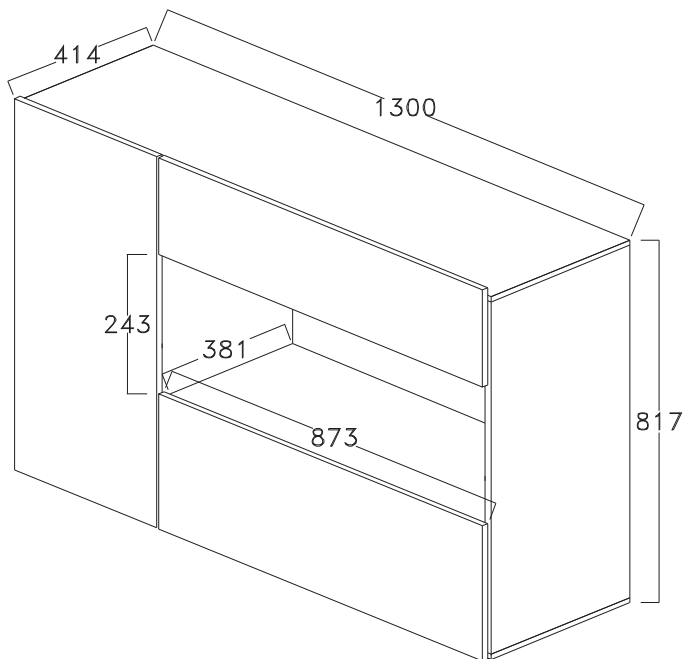
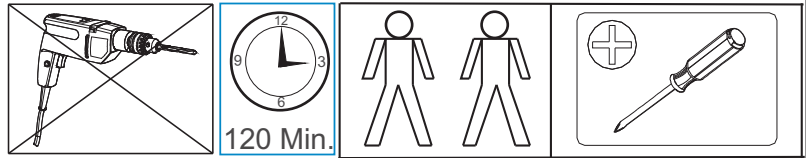

Total Kollis 1 Stuecke
 Total colli 1 pieces
 Numero total des colis:1
 Colli totali 1
 Totaal 1 colli's
 Razem sztuk 1
 Toplam parçalar 1
 Celkem baličky 1
 Teljes csomag 1
 Celkom baličky 1
 количество Всего 1
 Total colete 1
 Totalt antal kollin 1
 Ukupno koleta 1
 Bultos Totales 1
 Skupno število paketov 1

D Bitte lesen Sie diese Montageanleitung gut durch, da wir für Fehler, die durch falsche Montage entstehen, keine Haftung übernehmen!

GB Please read these installation instructions through carefully as we cannot accept any liability for faults occurring as a result of incorrect installation!

CZ Přečtěte si prosím pozorně tento návod k montáži, aby jste předešli chybám vzniklých špatnou montáží, za které neručíme!

F Veuillez lire attentivement cette notice de montage, car nous déclinons toute responsabilité en cas d'erreurs découlant d'un montage erroné !

I Prego leggere attentamente le istruzioni per il montaggio, poiché decliniamo qualsiasi responsabilità per difetti derivanti da un montaggio errato

S Läs monteringsanvisningarna noggrant. Vi avsåger oss allt ansvar för defekter som uppstår p.g.a. felaktig montering.

HR Pažljivo pročitajte upute za montažu, jer otklanjamo svaku odgovornost za pogreške nastale uslijed pogrešne montaže.

SLO Prosimo, da pozorno preberete navodila za montažo, saj zavračamo vsakršno odgovornost za napake, ki bi nastale zaradi napačne montaže.

NL Leest u alstublieft deze montagehandleiding goed door, voor fouten door verkeerde montage zijn wij niet verantwoordelijk.

PL Proszę uważnie zapoznać się z instrukcją montażu, ponieważ nie ponosimy odpowiedzialności za niewłaściwy montaż.

HU Kérjük, olvassa el figyelmesen ezt az összeszerelési útmutatót, mert a helytelen összeszerelésből a dődő hibáért nem vállalunk felelősséget!

SK Prosíme, dobre prečítajte si tento návod na montáž, pretože nepreberáme žiadne ručenie za chyby, ktoré vzniknú na základe chybnej montáže!

RO Vă rugăm să citiți cu atenție aceste instrucțiuni de montaj deoarece nu preluăm garanția pentru defecte ce apar datorită unui montaj incorect!

RUS Пожалуйста, внимательно ознакомьтесь с данной инструкцией по монтажу, поскольку мы не несем ответственности за ошибки, причиной которых является неправильный монтаж.

TU İlkonce kullanma klavuzunu iyi okuyun, yalnız montaj yapasınız bunun sorumlusu biz degiliz.

E Se ruego leer con atención las instrucciones de montaje debido a que declinamos cualquier responsabilidad por defectos derivados de un montaje erróneo

ONDERDELEN LYST-SERVICEKARTE-FORMULAIRE DEMANDES SAV-SPAREPARTS LIST-SCHEDA DI SERVIZIO

BESLAG-BESCHLAEGE – QUINCALLERIE – HARDWARE – FERRAMENTA

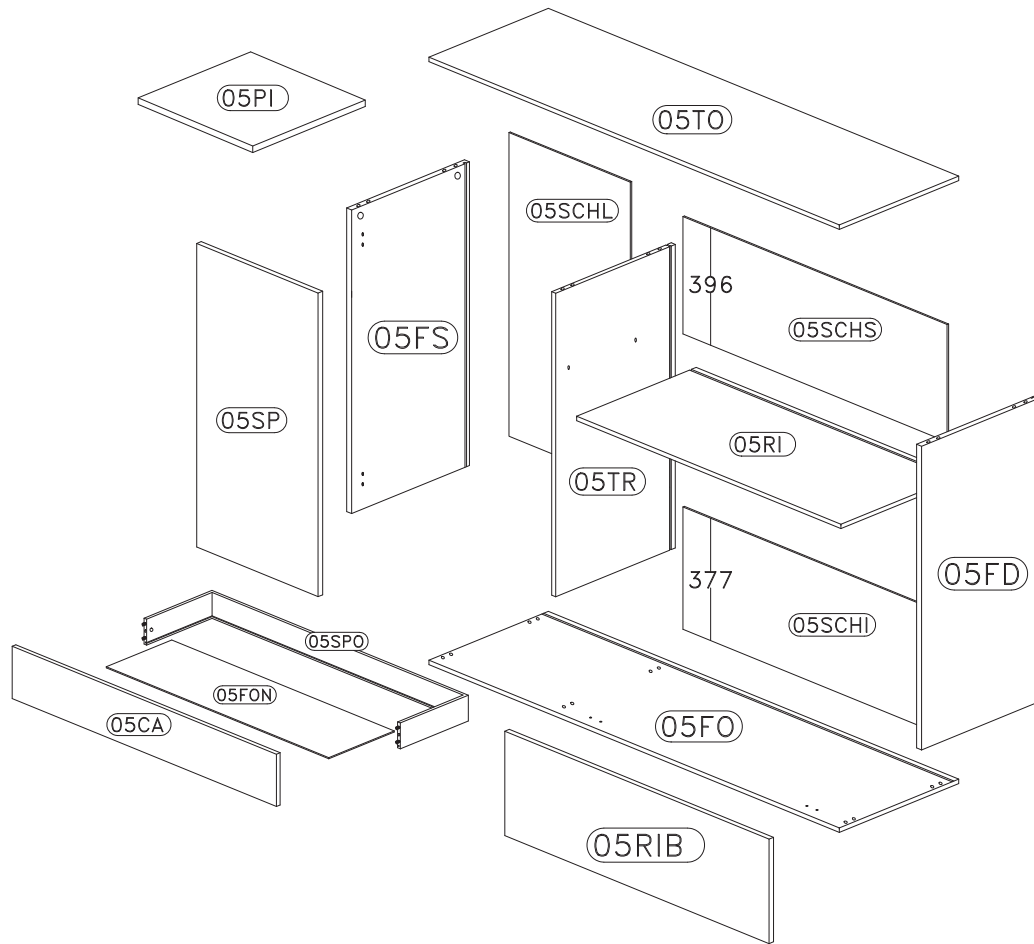

A		x22	R4		x4	CL		x1
B		8x30 mm. x12	R2		x4	CR		x1
C		ø16 mm. x6	L		4.5x30 mm. x5	DR		x1
D		x6	M2		3.5x16 mm. x12	DL		x1
E		7x60 mm. x6	M9		6x9 mm. x4	L2		4x16 mm. x8
P		x6	M11		6x11 mm. x4	N1		x4
P2		x2	P12		ø20 mm. x2	O		x4
F19		ø 60 mm h 20 mm x5	C1		ø12 mm. x2	D1		x2

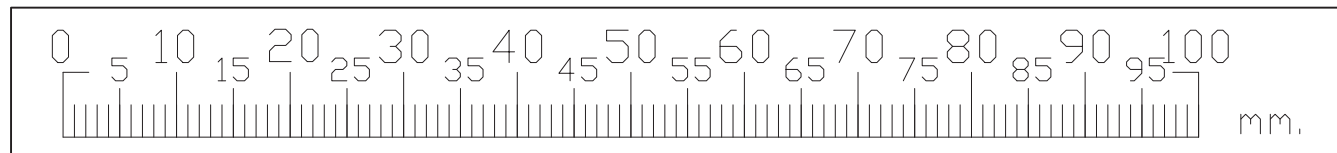

1

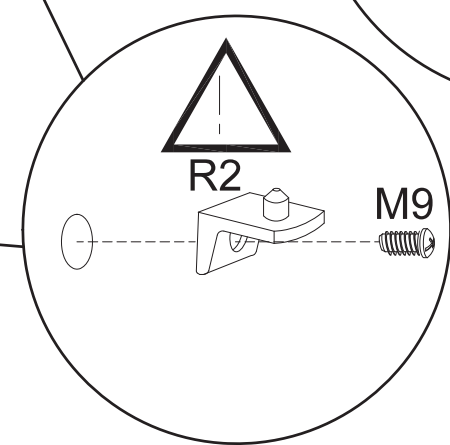
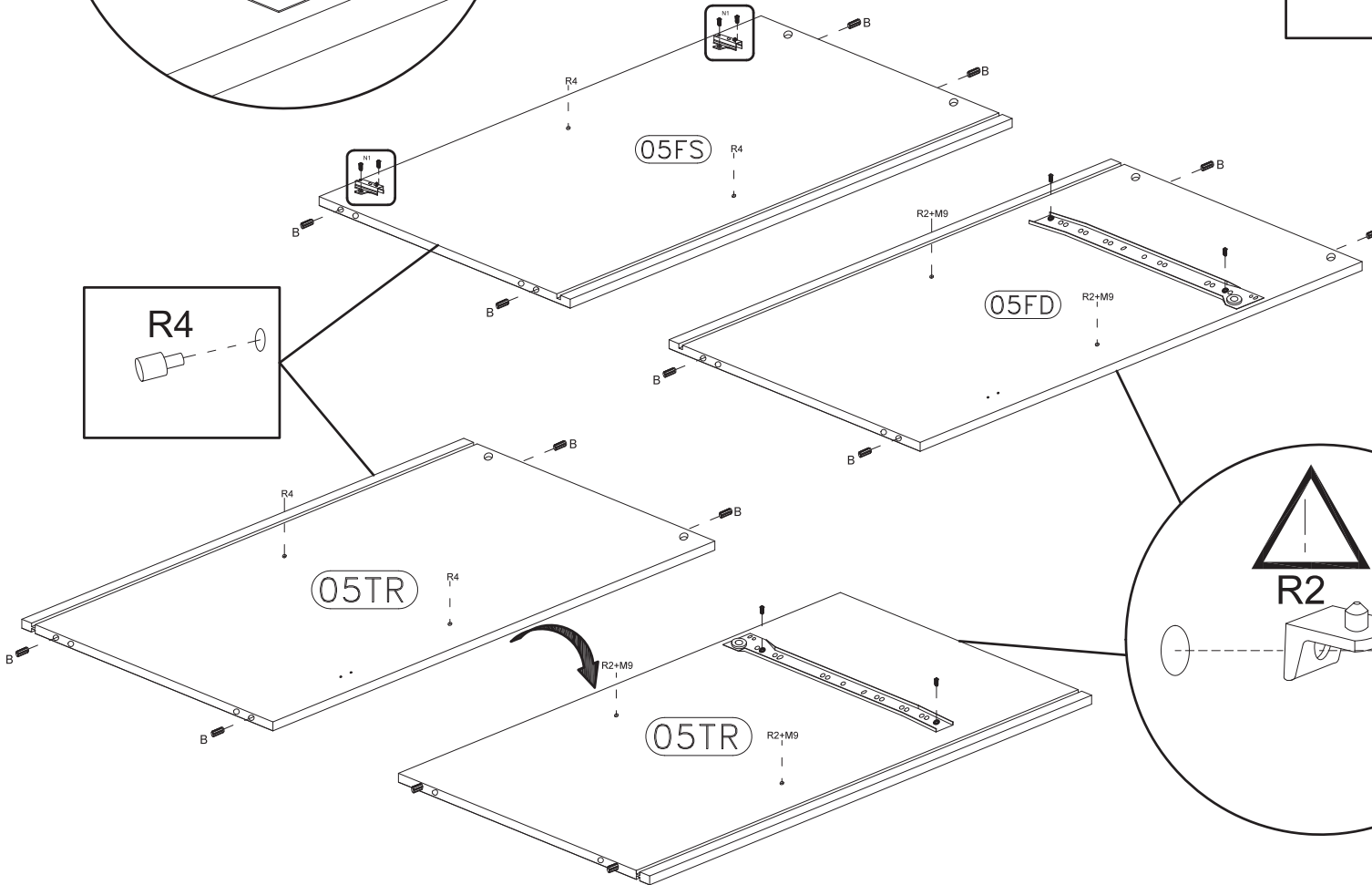
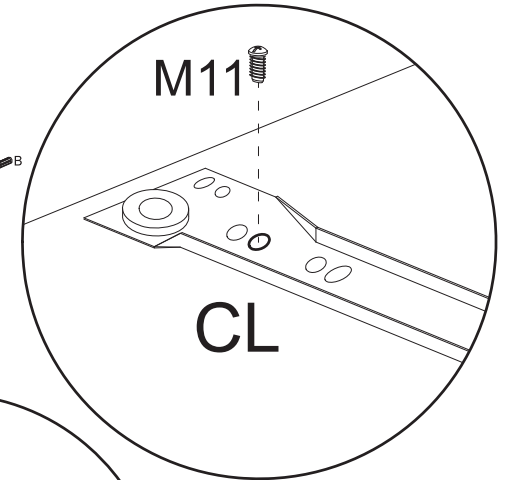
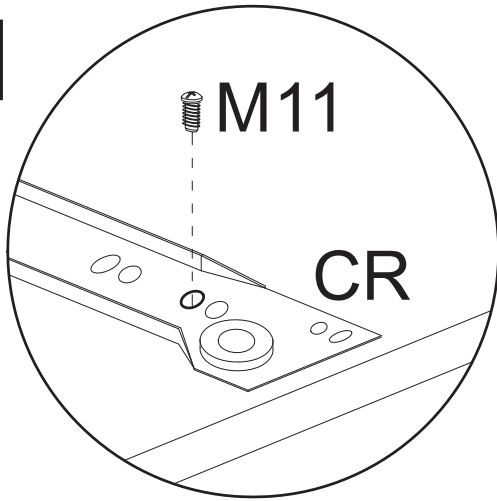
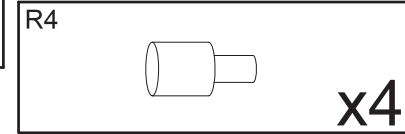
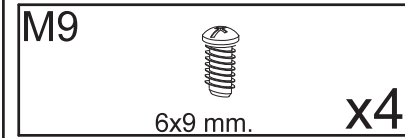
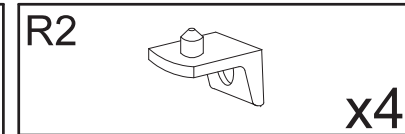
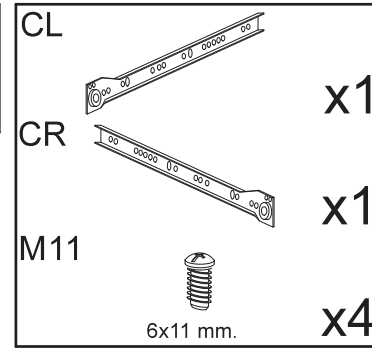
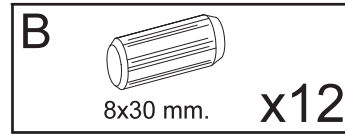

2

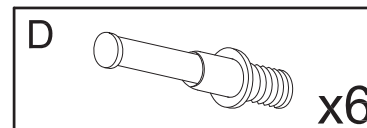
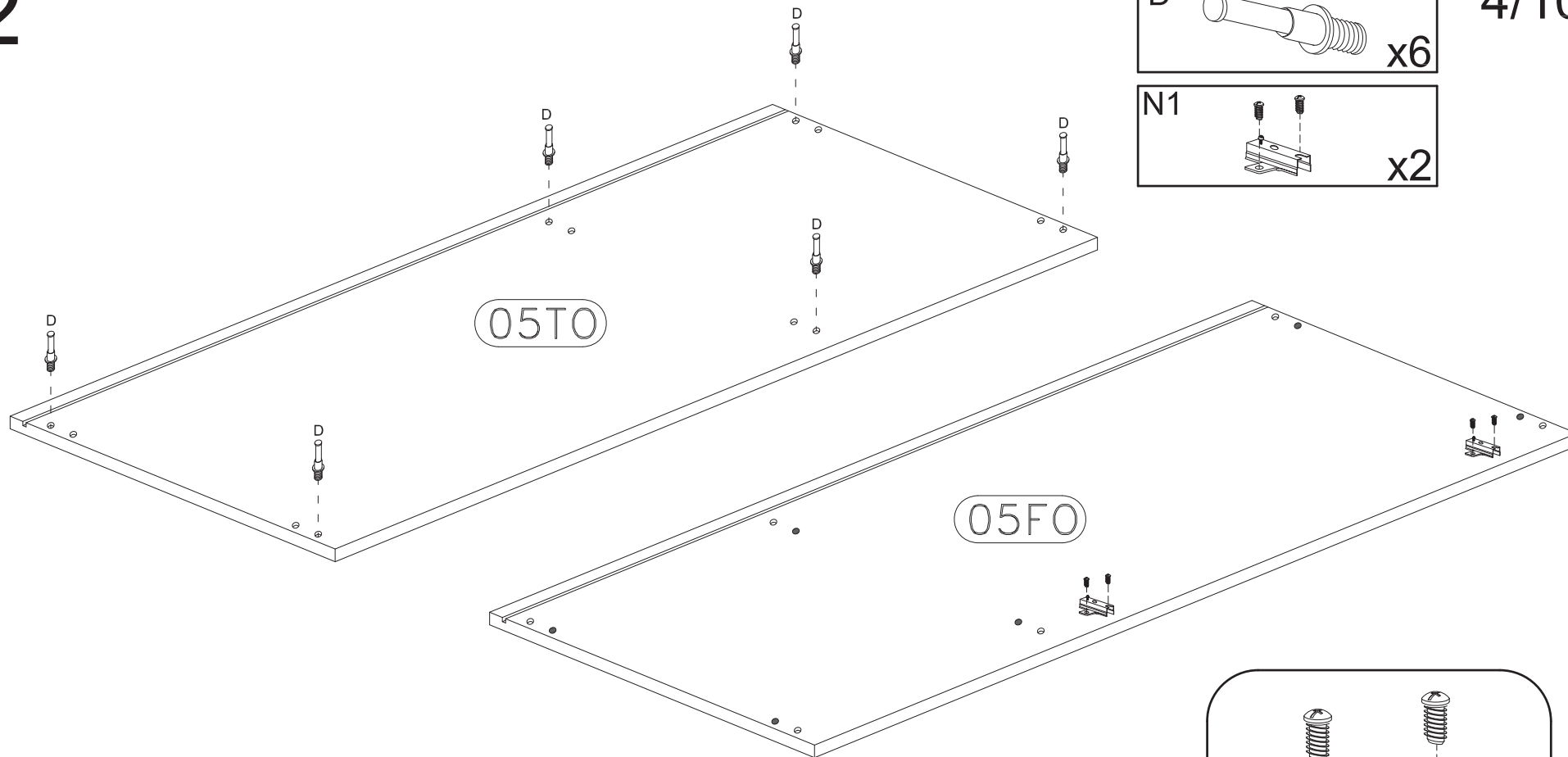

4/10

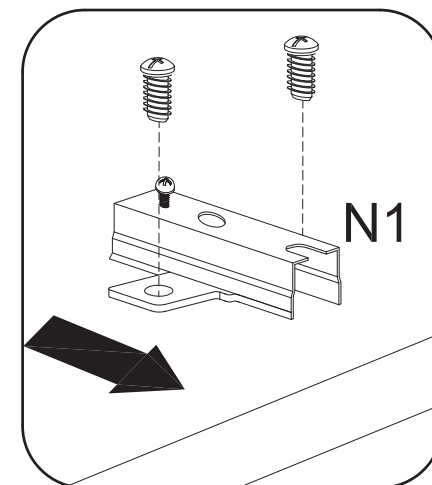
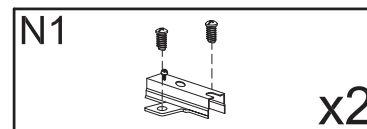

3

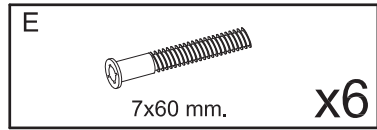
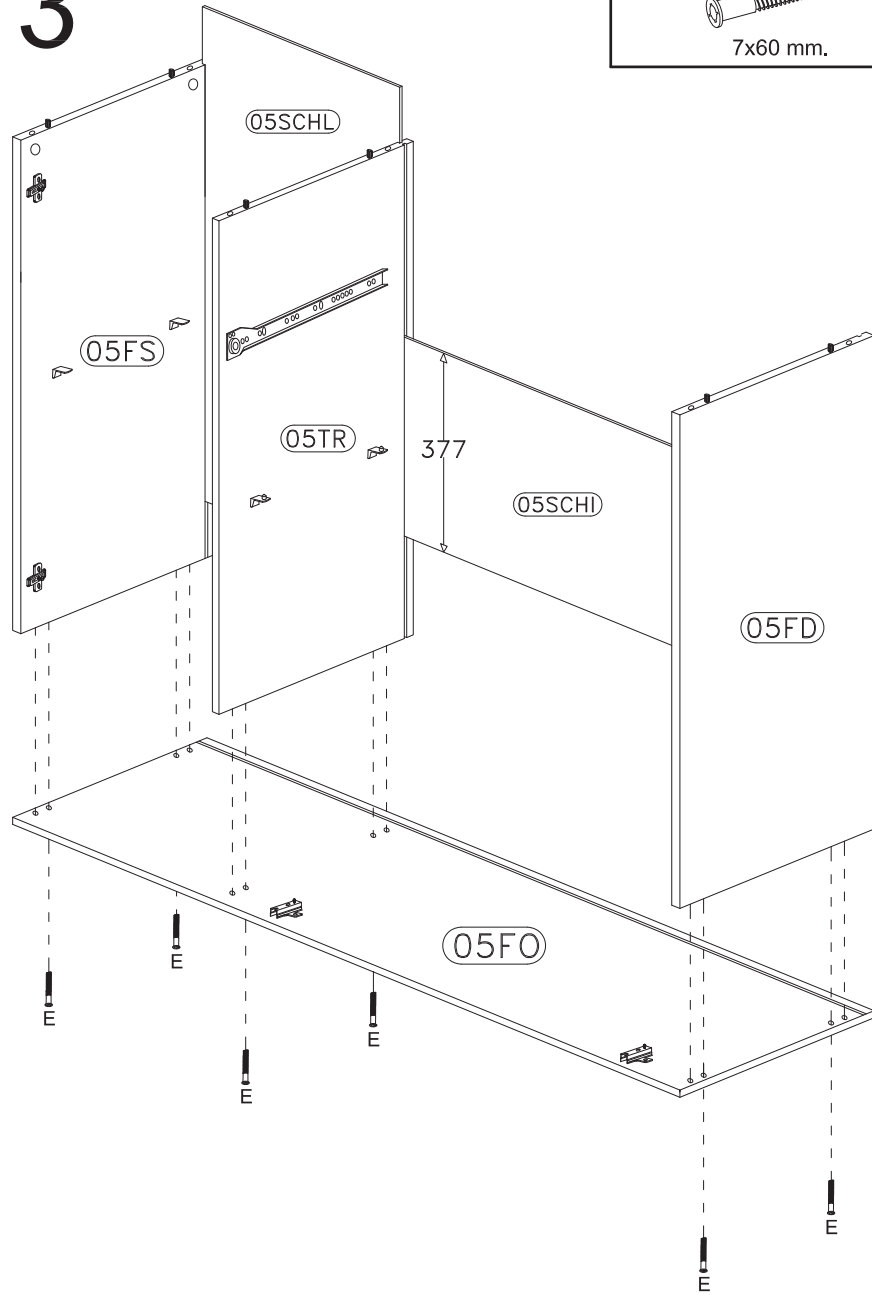

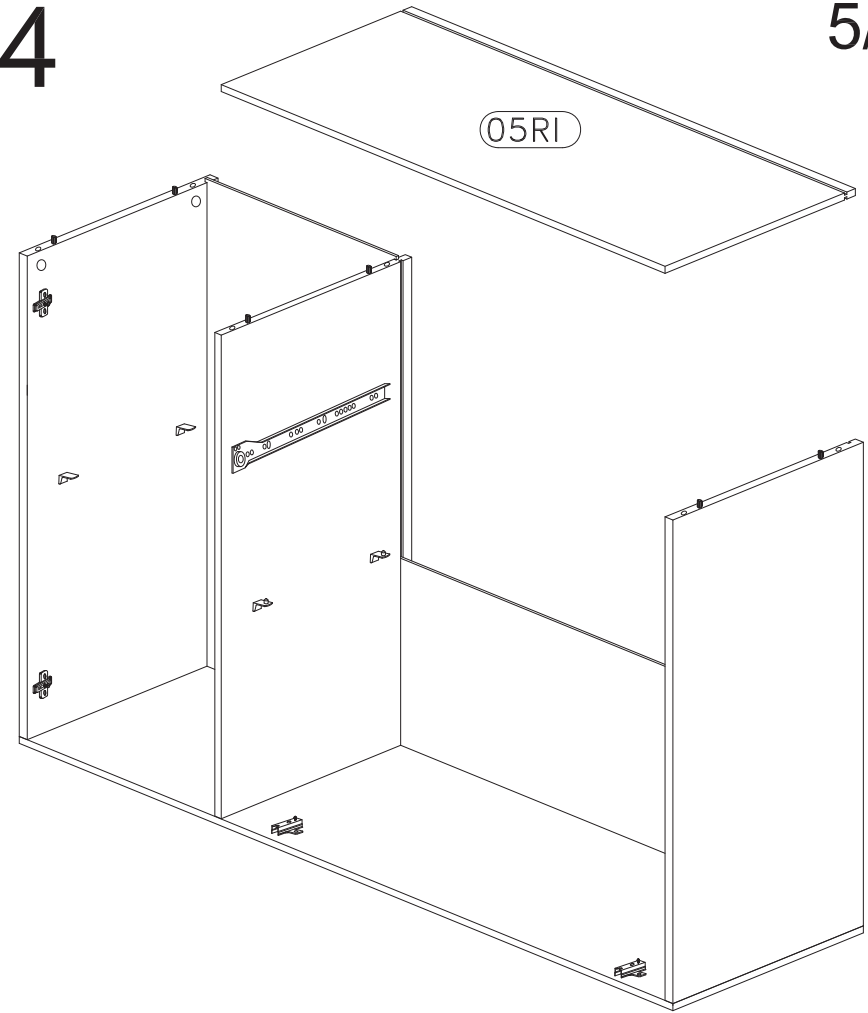

4

5/10

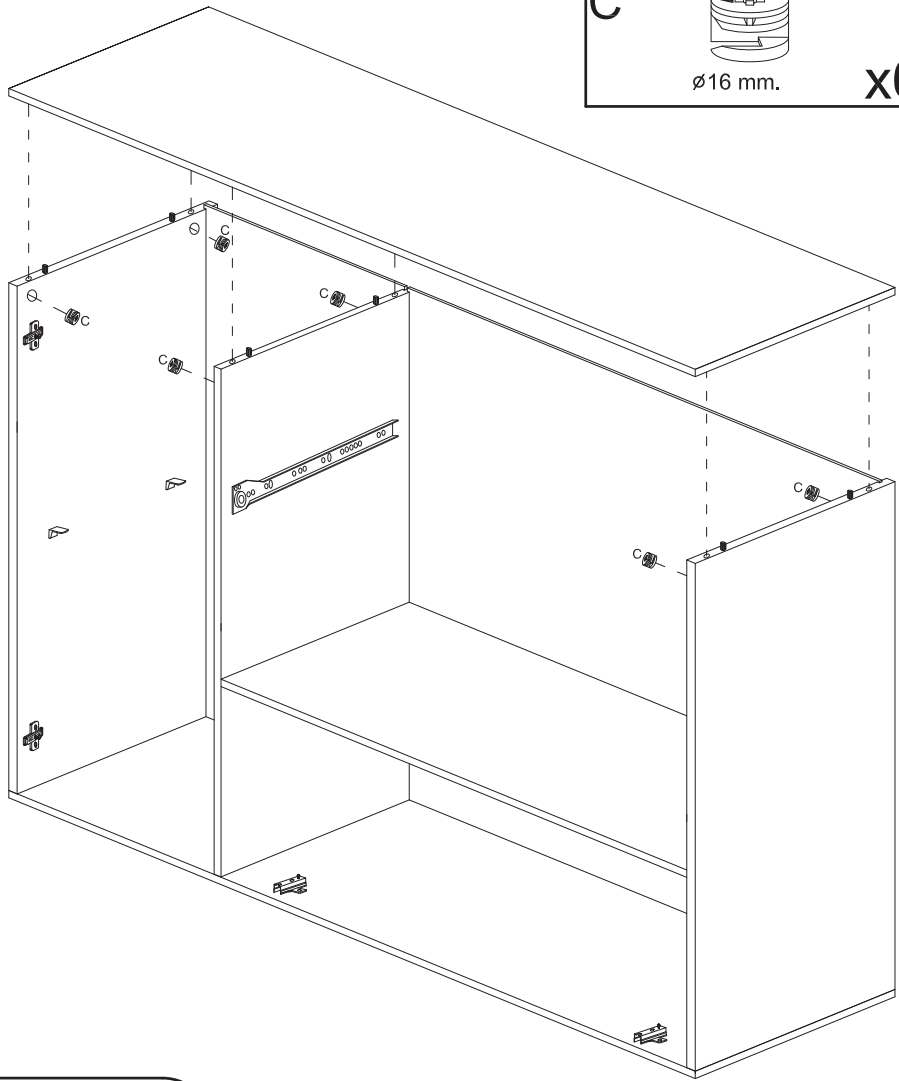

5



C  $\varnothing 16 \text{ mm.}$ **x6**

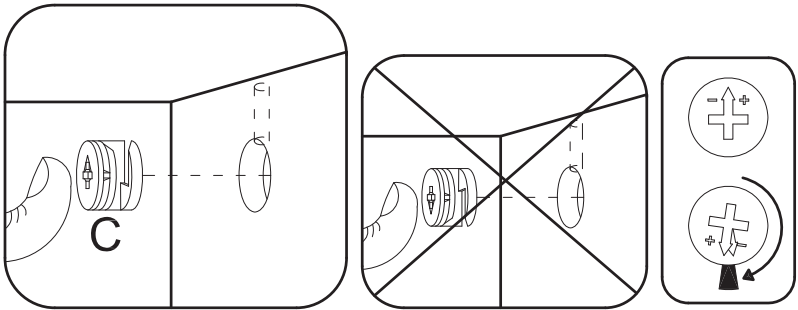

6

A  **x18**

6/10

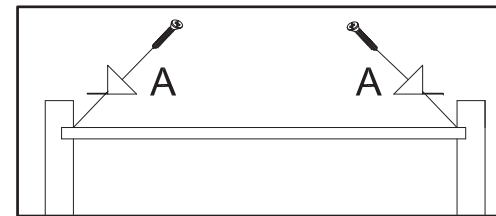
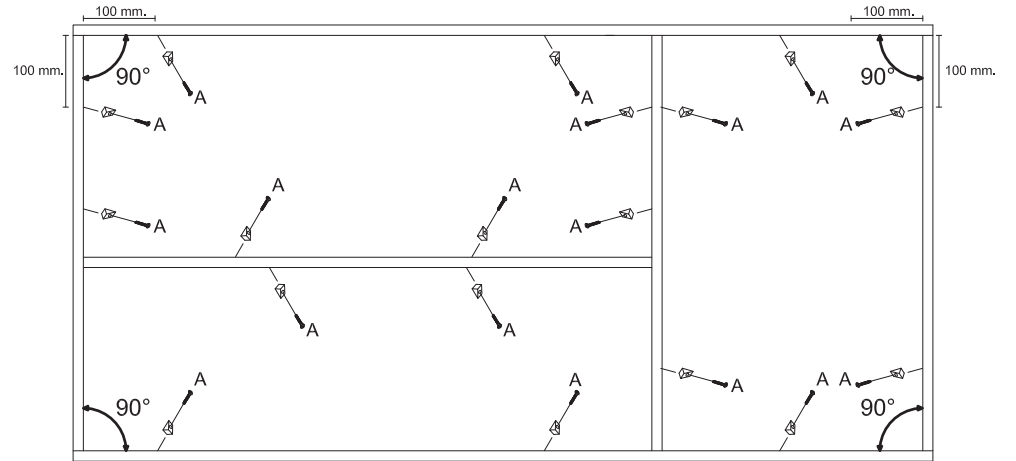

7

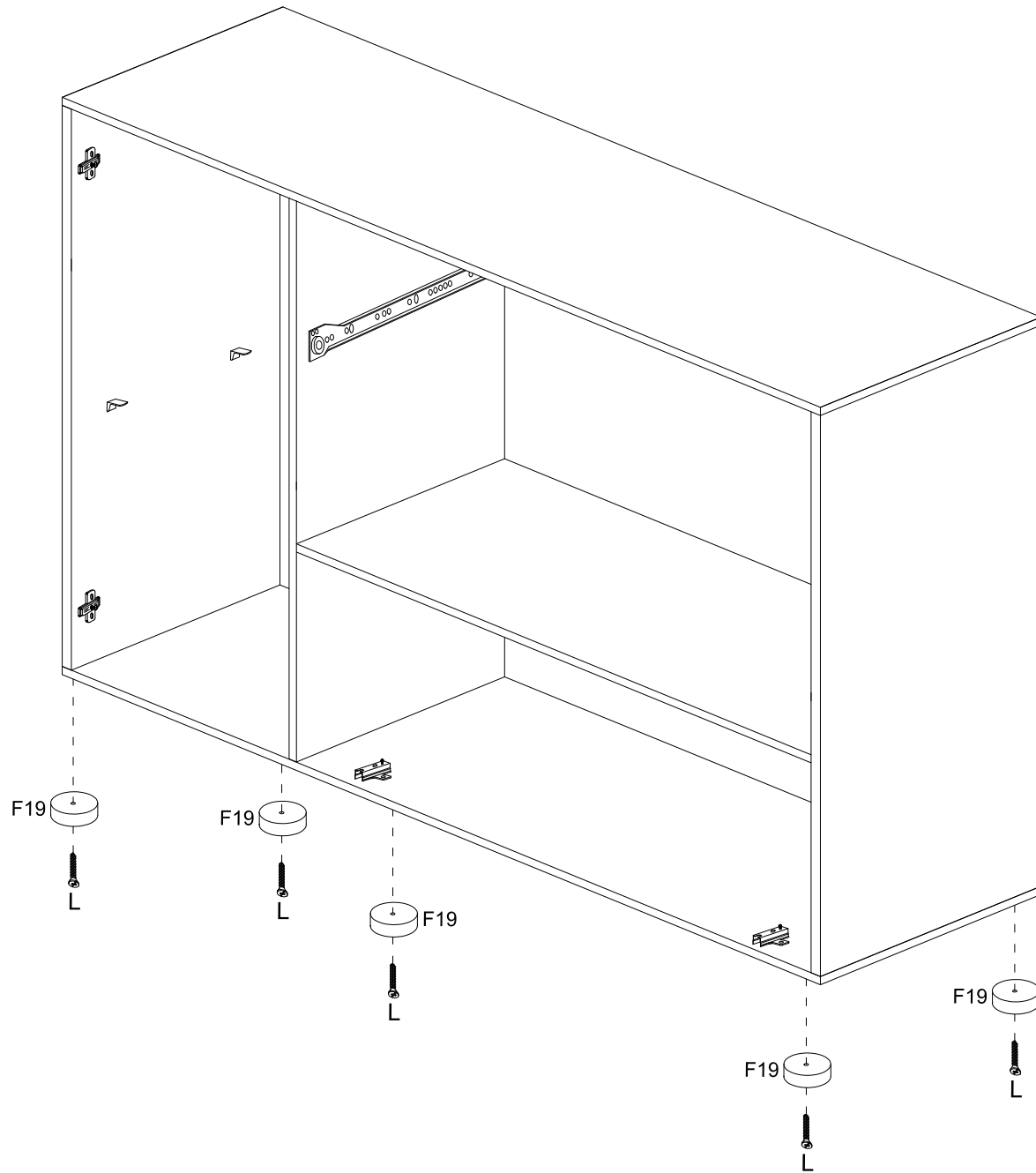

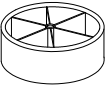
- L  4x30 mm. x5 7/10
- F19  Ø 60 mm h 20 mm x5

9

L2		
	4x16 mm.	x8

8/10

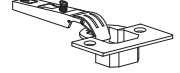
O		x4
P		x4

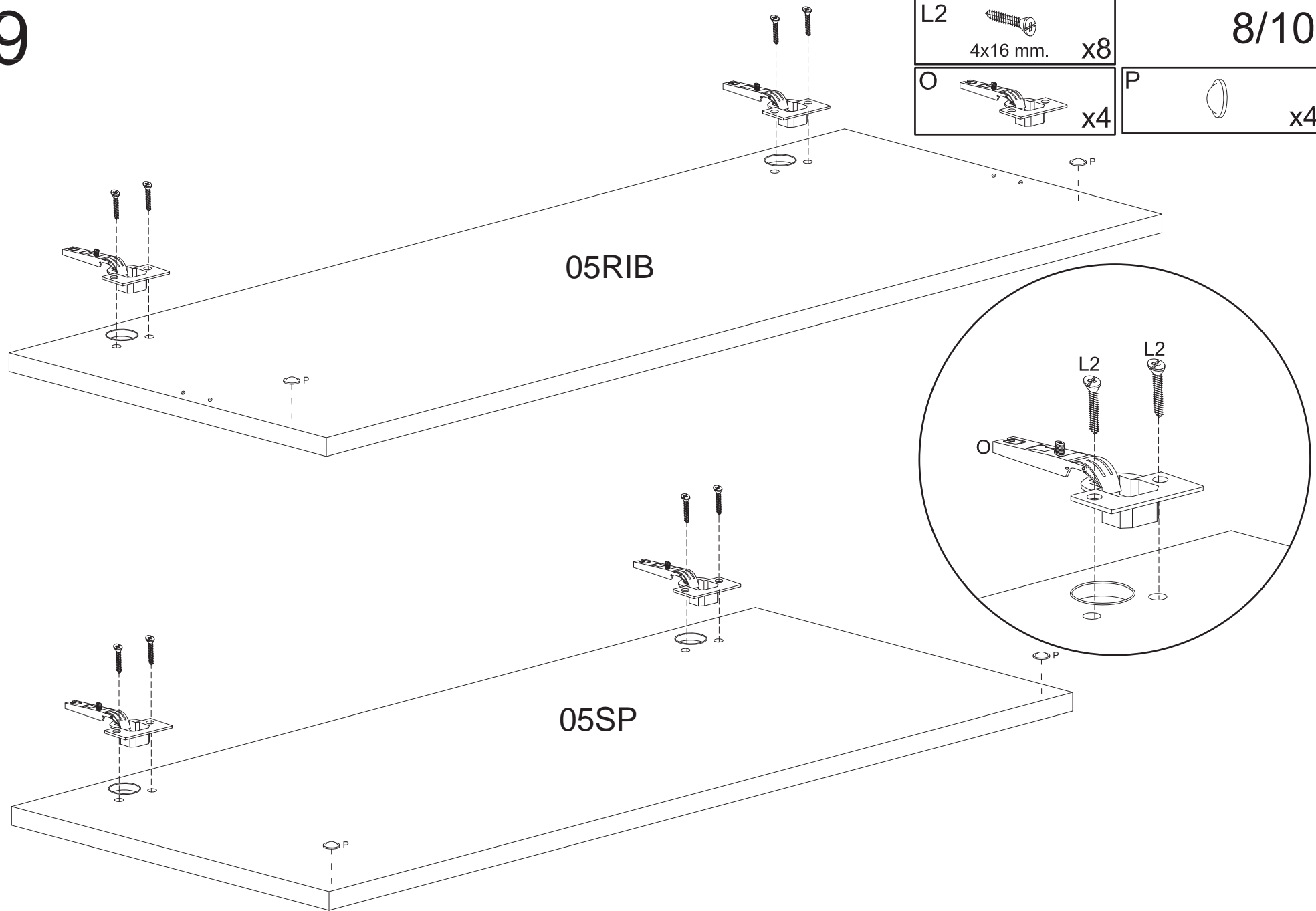

11

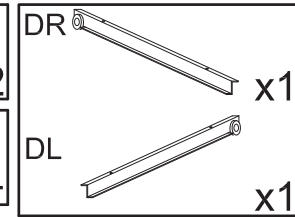
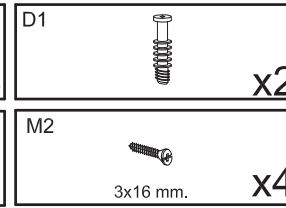
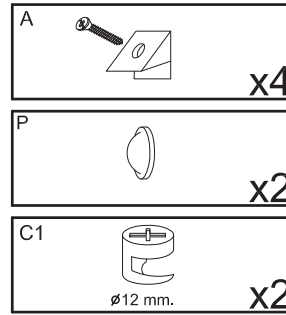
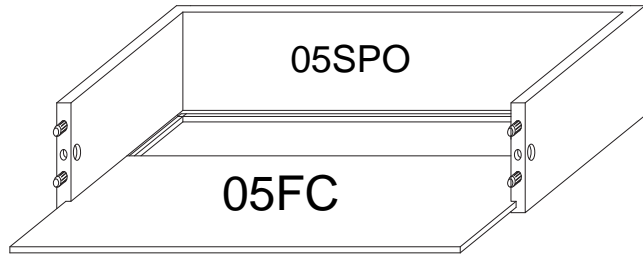

9/10

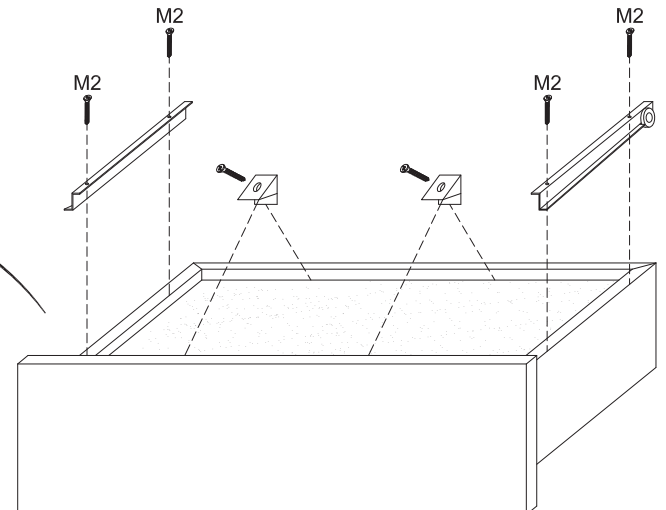
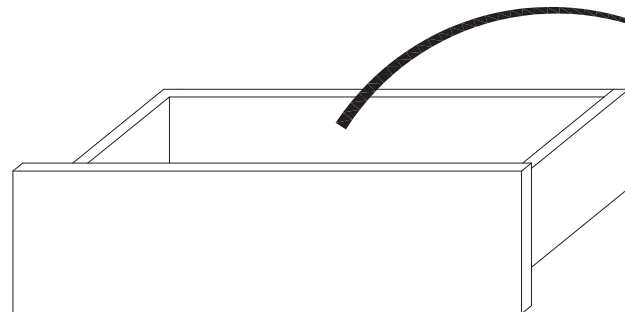
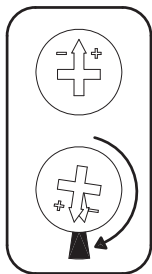
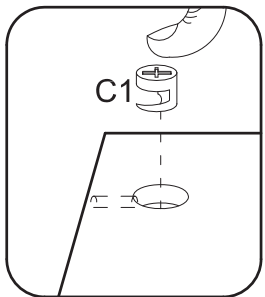
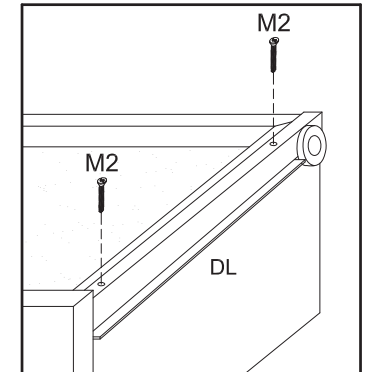
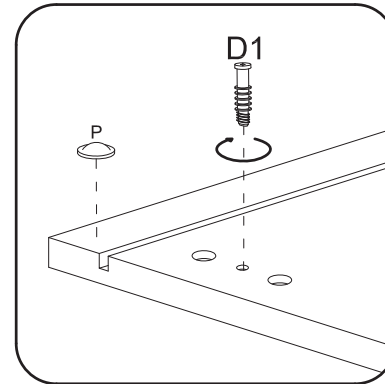
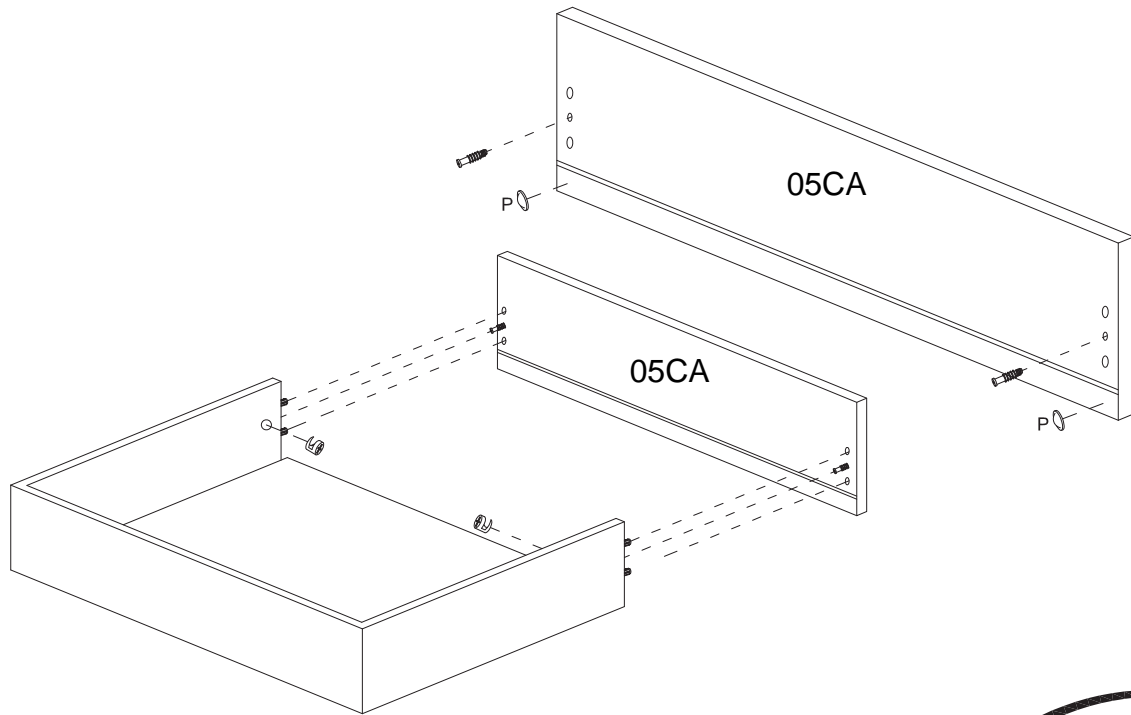

12

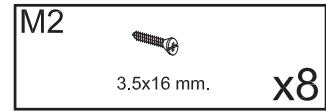
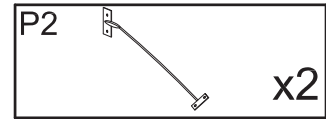
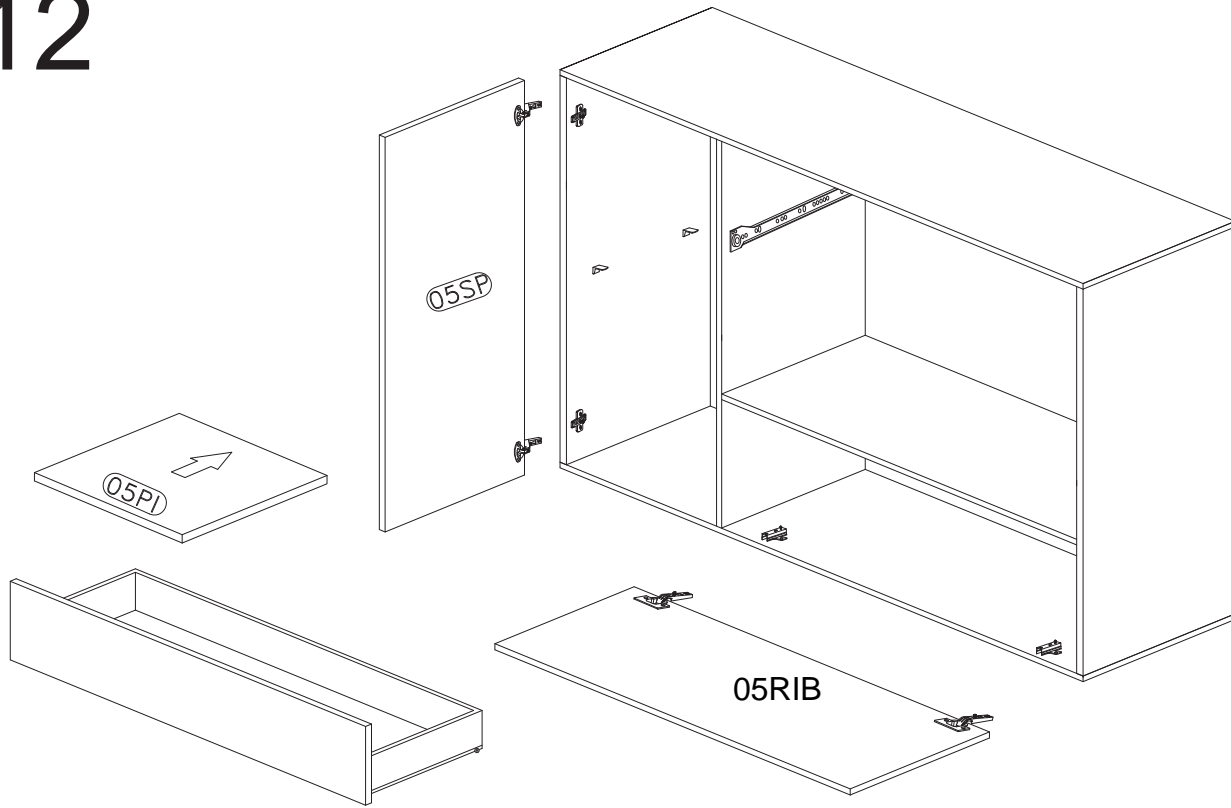

10/10

