

# ASSEMBLY INSTRUCTION

---

Thank you for purchasing the quality product. Be sure to check all packing material carefully for small parts which may have come loose inside the carton during shipment. Separate, identify and count all parts and metal hardware. Compare with all parts list to be sure all parts are present. If any part(s) are missing or damaged, please contact your local furniture dealer. For efficient and speedy service, please indicate the model number and code letter of part(s) needed.

**\*\*\*Do not fully tighten screws until fully assembled\*\*\***

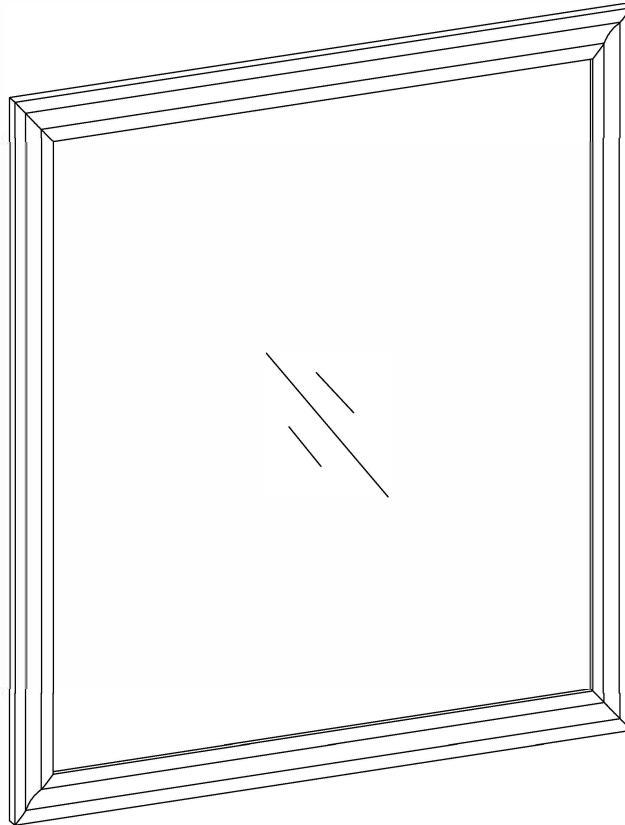

## Attention:

\*\*\*Some number parts listed on the instruction sheet may not be in parts bag as they may already be assembled. Carefully check parts and packing materials prior to ordering replacements.

# General Assembly Guidelines

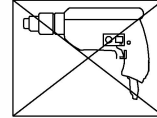

- I. Ensure that all parts and hardware are available before beginning assembly.
- II. Follow each step carefully to ensure the proper assembly of this product.
- III. Two people are recommended for ease in the assembly of this product.
- IV. Power tools should not be used to assemble this product.



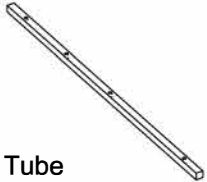

## COMPONENT PARTS

DESCRIPTION	PART NAME	QTY(PCS)	DESCRIPTION	PART NAME	QTY(PCS)
①	 Mirror	1	②	 Metal Tube	2

## Hardware List

A		Ø6x30mm	Bolt	8 pcs
B		4mm	Allen Key	1 pcs

# Step 1

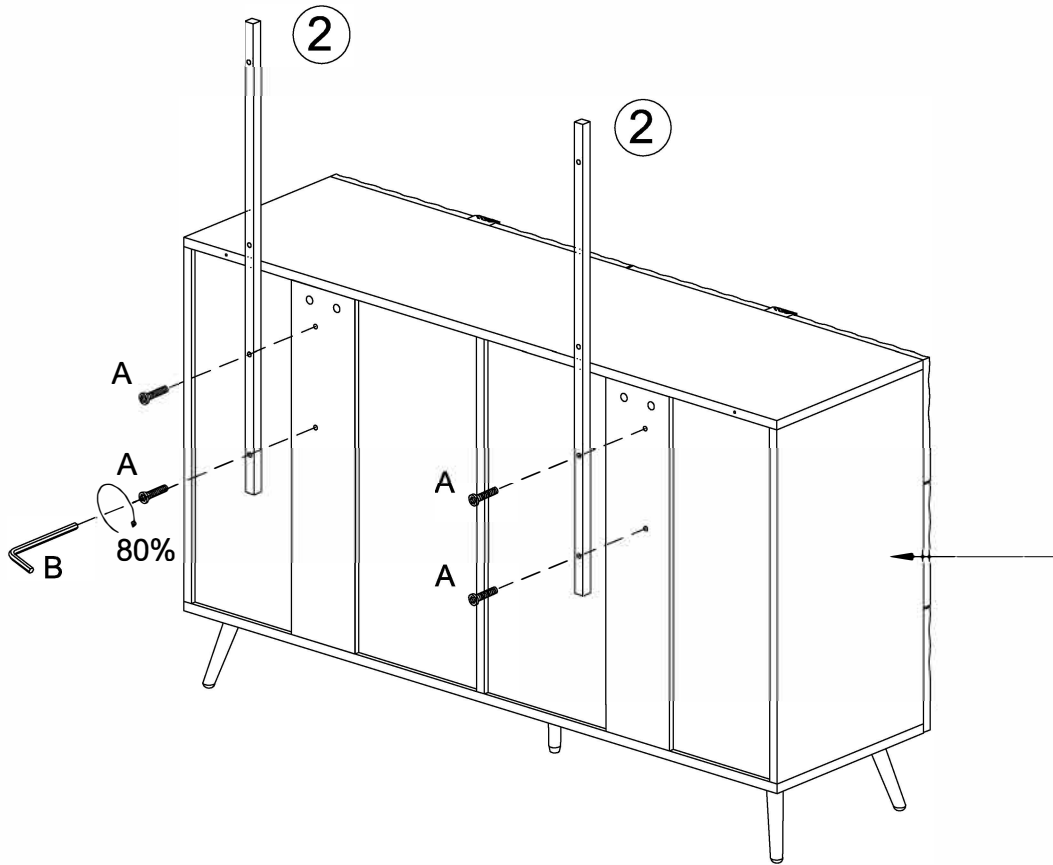

A x 4	B x 1
 Ø6x30mm	 4mm

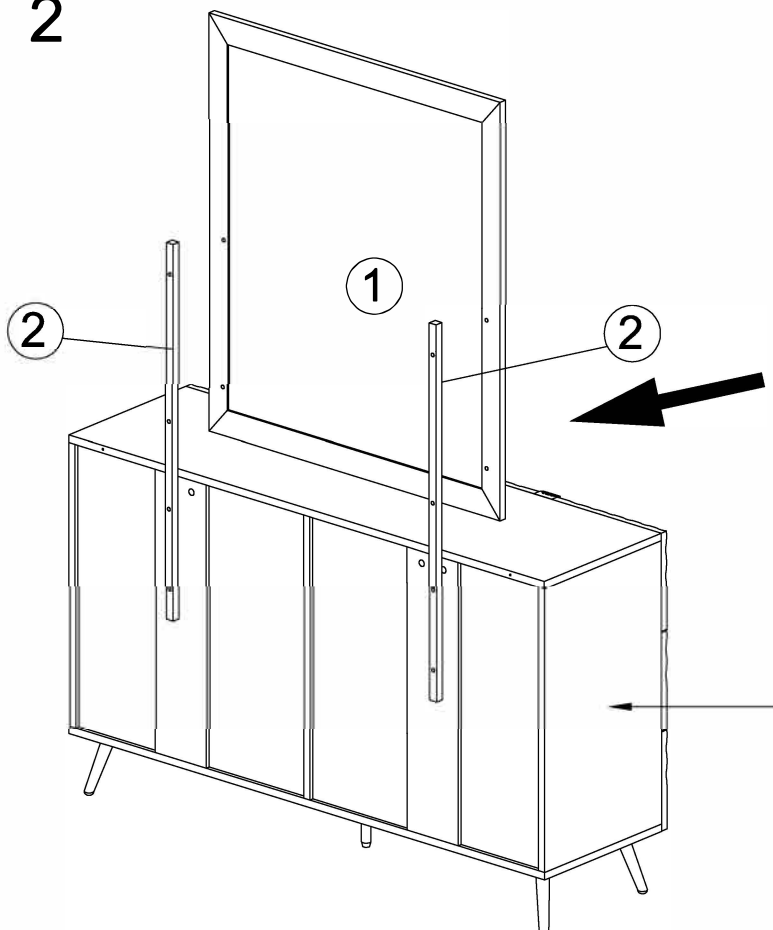

# Step 2



# Step 3

A x 4	B x 1
 Ø6x30mm	 4mm

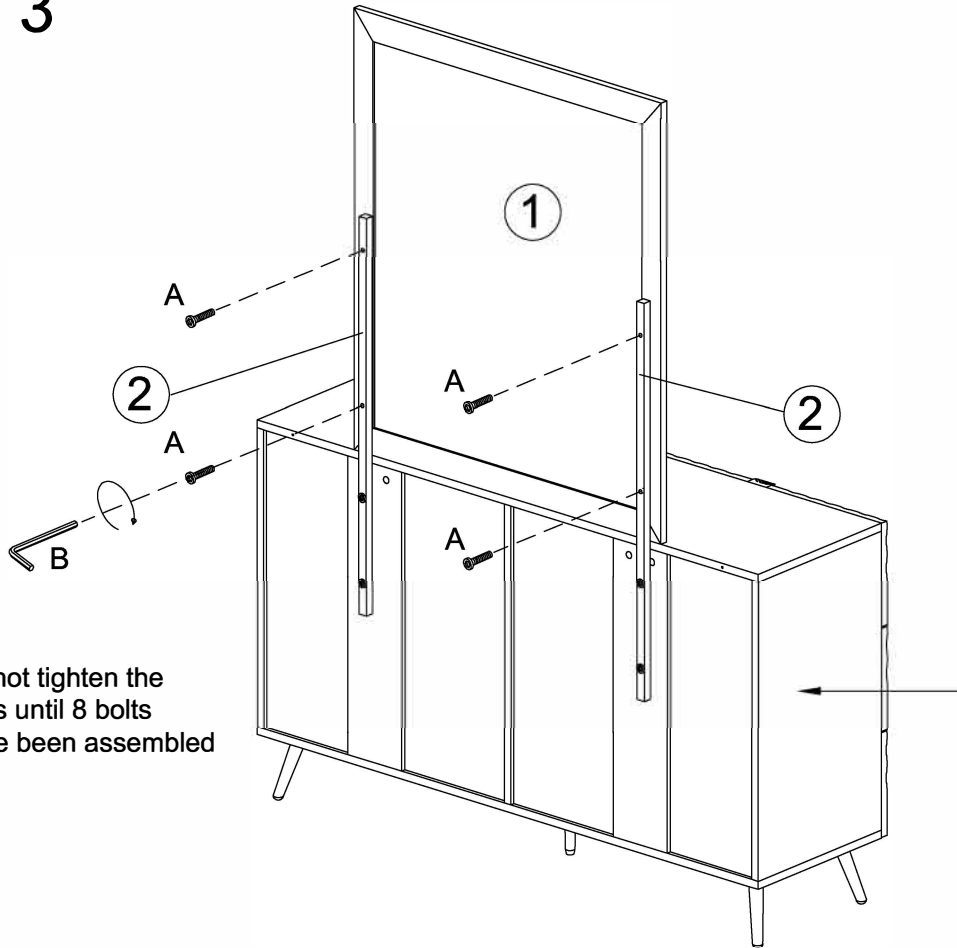

# Step 4

