

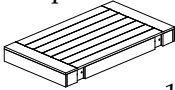

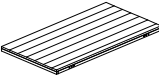

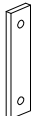

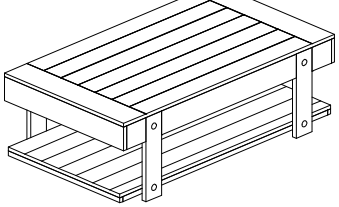

Occasional Tables Assembly Instructions

Page 1 of 1

Made in China

Components and Hardware List

<p>Table Top</p>  <p>(A) 1 pc.</p>	<p>Shelf</p>  <p>(B) 1 pc.</p>	<p>Post</p>  <p>(C) 4 pcs.</p>	 <p>COCKTAIL TABLE</p>
<p>Ø5/16-18 x 1-3/4" Allen Head Bolt</p>  <p>(D) 16 pcs.</p>	<p>5/16" Spring Washer</p>  <p>(E) 16 pcs.</p>	<p>5/16" Flat Washer</p>  <p>(F) 16 pcs.</p>	
<p>5mm Allen Wrench</p>  <p>(G) 1 pc.</p>	<p>Dowel M10 x 30mm</p>  <p>(H) 4 pcs.</p>	<p>Caster</p>  <p>(I) 4 pcs.</p>	
			<p>Open Wrench</p>  <p>(J) 1 pc.</p>

Be sure to check all packing material carefully for small parts, which may have come loose inside the carton during shipment. To prevent possible scratches or damage, this product should be assembled on a soft surface such as a blanket or carpet, or its own packaging material.

ASSEMBLY STEPS:

Step 1: Place the Table Top (A) upside down on a soft non-abrasive surface.

Step 2: Attach the Legs (C) to the underneath side of the Table Top with the 1-3/4" long Bolts (D), Spring Washers (E) and Flat Washers (F). Do not fully install or tighten Bolts until after Shelf is assembled.

Step 3: Attach the Shelf (B) near the bottom of the Legs with the Dowel (H), the 1-3/4" long Bolts (D) and Washers as in previous step. Adjust parts for fit to each other if necessary and tighten all Bolts with the Allen Wrench (G).

Step 4: If the Casters (I) will be used: Attach to the bottom of the Shelf and tighten with the Open Wrench (J).

Step 5: Carefully set the assembled Table upright.

To prevent possible damage to some types of flooring, never roll casters on unprotected hardwood or vinyl flooring.

STEP 1, 2

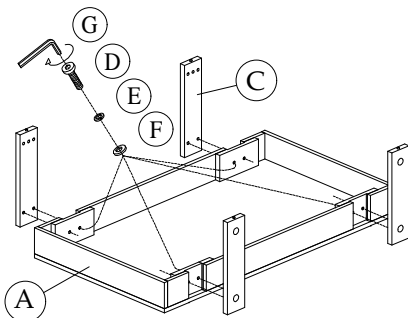

STEP 3

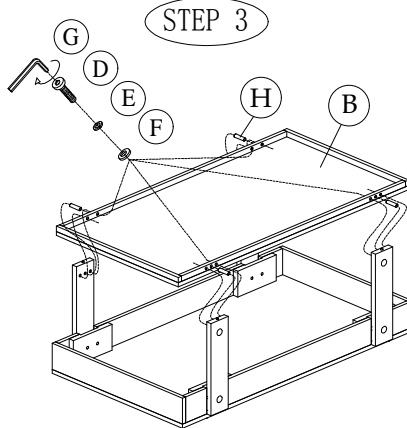

STEP 4

