

CARE AND MAINTENANCE

Store outdoor furniture indoors or cover well when not in use.

Remove wooden furniture from standing water. Dust regularly with small brush or vacuum

Spills should be taken care of immediately before they harden or stain with a slightly dampened sponge.















NOTICE

- * Please make sure that you have all parts indicated before you begin assembly of this item
- * This item should be assembled on a soft surface to prevent scratching the finish during assembly
- * This item may require periodic tightening

Weight Capacity : 275 lbs (single seat)
550 lbs (two person seat)
Warning : Do not stand on bench
Warning : Do not over torque bolts/screws





Part List and Hardware List

PIECE	DESCRIPTION	PICTURE	QUANTITY
1	Back Bench Frame		2X
2	Seat Bench Frame		2X
3	Right Frame		2X
4	Left Frame		2X
5	Table Frame		1X
6	Leg Frame		2X
7	Side FrameTable		2X
8	Seat Cushion		2X
A	Allen Bolt M6x40		4X
B	Allen Bolt M6x25		4X
C	Allen Bolt M6x20		20X
D	Flat Washer M8*18*T1		28X
E	Washer M8*18*T5		4X
F	Allen Key		1X

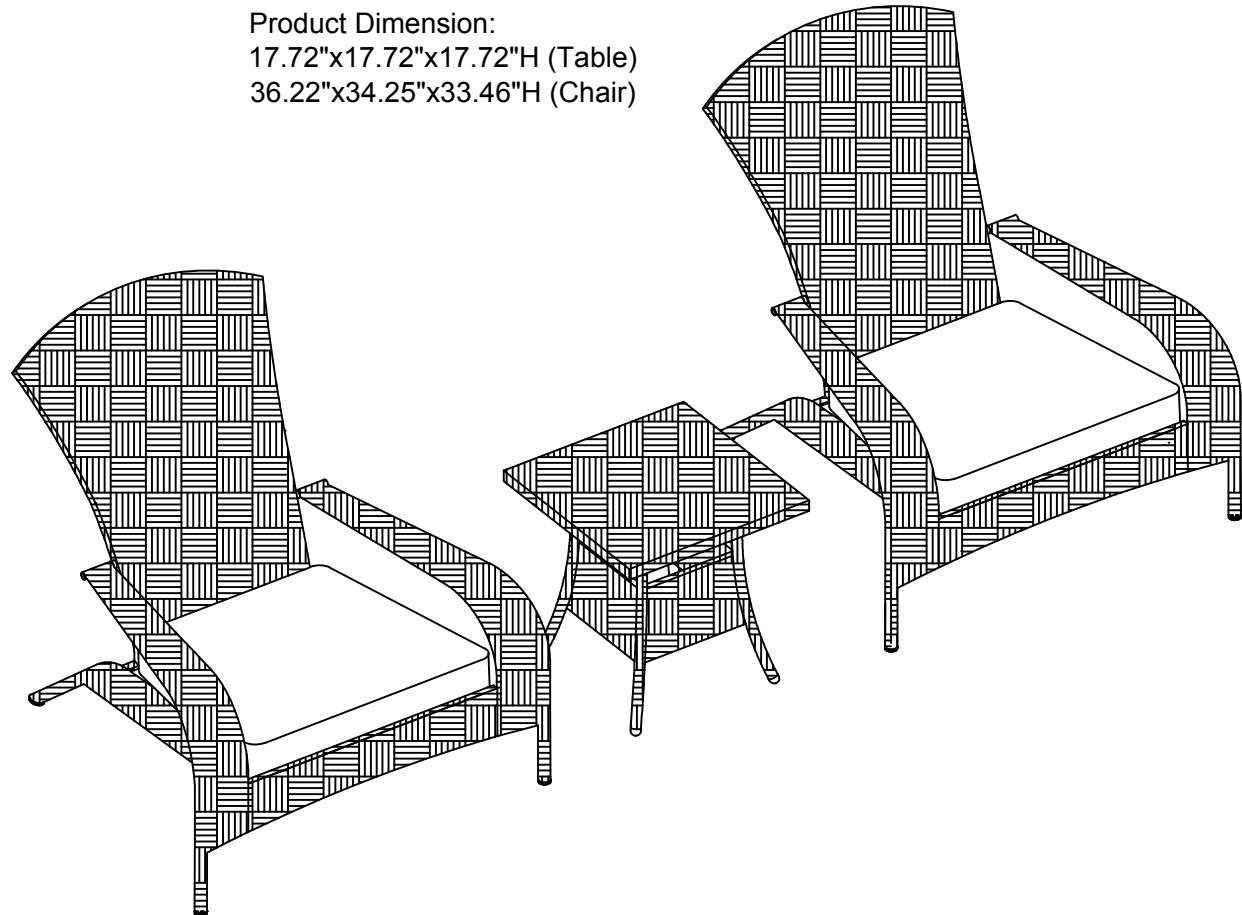
Product Dimension:
 17.72"x17.72"x17.72"H (Table)
 36.22"x34.25"x33.46"H (Chair)

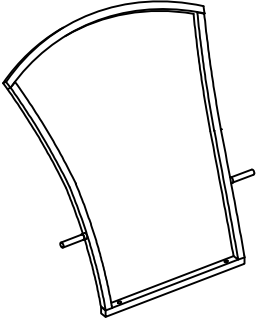
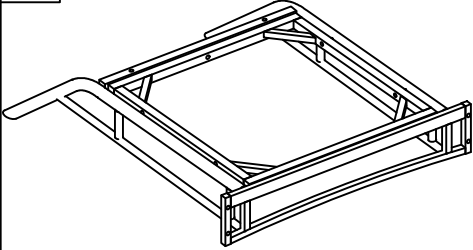
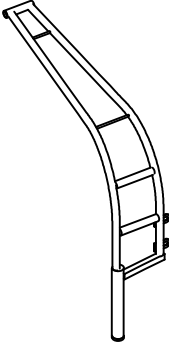
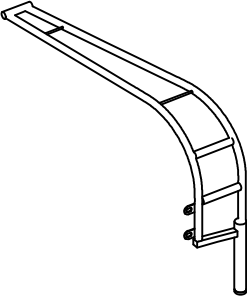
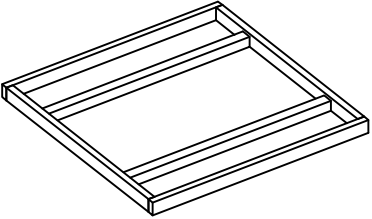
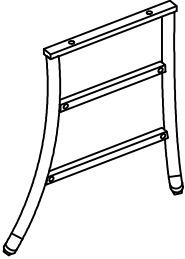
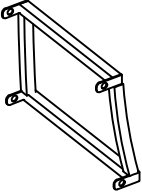
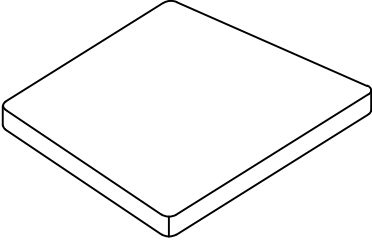
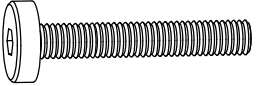
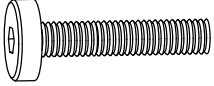
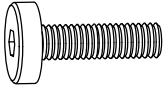
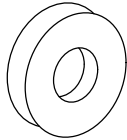
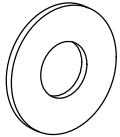

<p>1</p>  <p>Back Bench Frame (2 Pcs)</p>	<p>2</p>  <p>Seat Bench Frame (2 Pcs)</p>	<p>3</p>  <p>Right Frame (2 Pcs)</p>	<p>4</p>  <p>Left Frame (2 Pcs)</p>
<p>5</p>  <p>Table Frame (1 Pc)</p>	<p>6</p>  <p>Leg Frame (2 Pcs)</p>	<p>7</p>  <p>Side FrameTable (2 Pcs)</p>	<p>8</p>  <p>Seat Cushion (2 Pcs)</p>
<p>A</p>  <p>Allen Bolt M6x40 (04 Pcs)</p>	<p>B</p>  <p>Allen Bolt M6x25 (04 Pcs)</p>	<p>C</p>  <p>Allen Bolt M6x20 (20 Pcs)</p>	<p>E</p>  <p>Washer M8*18*5 (04 Pcs)</p>
		<p>D</p>  <p>Flat Washer M8*18*1 (28 Pcs)</p>	<p>F</p>  <p>Allen Key (1Pc)</p>

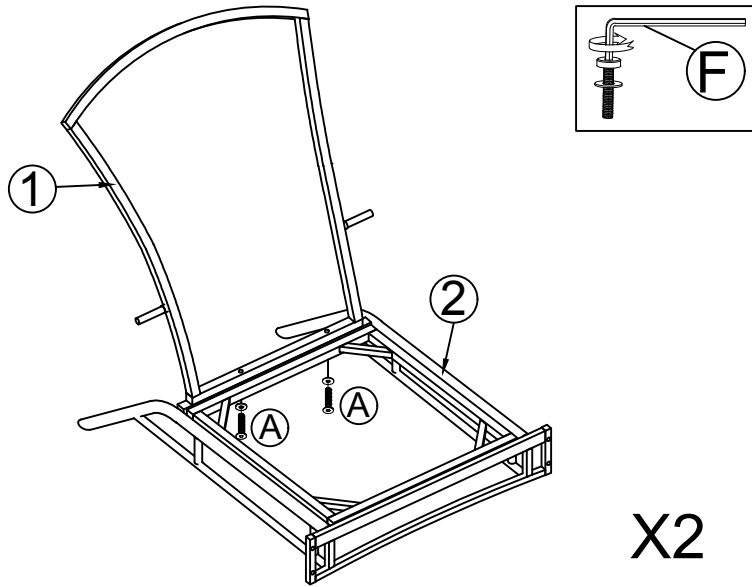

X2

STEP 1: Connect Seat Bench Frame (2) & Back Bench Frame (1), tighten Allen Bolt (A), Flat Washer (E) with Allen Key (F).

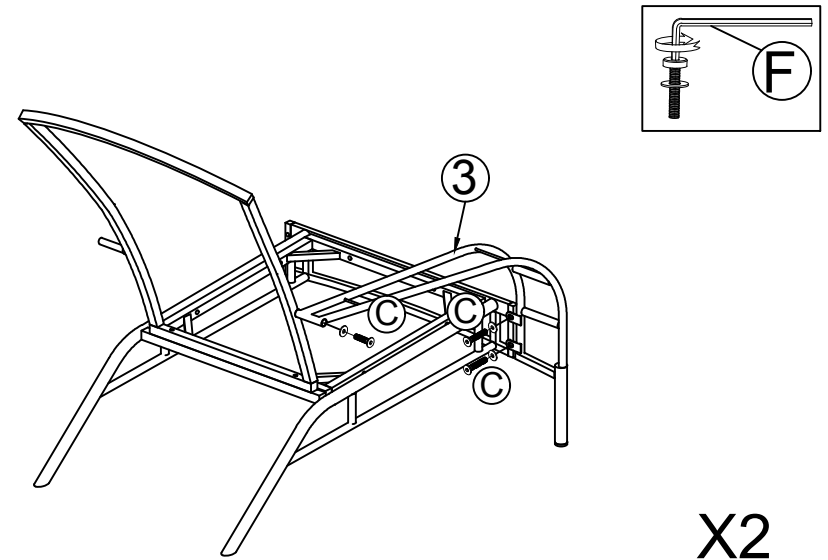

X2

STEP 2: Connect the part from Step 1 & Right Frame (3), tighten Allen Bolt (C), Flat Washer (E) with Allen Key (F).

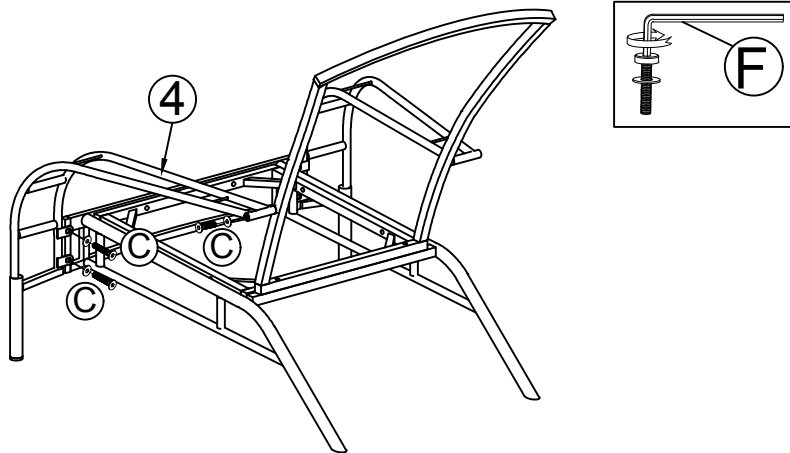

X2

STEP 3: Connect the part from Step 2 & Left Frame (4), tighten Allen Bolt (C), Flat Washer (E) with Allen Key (F).

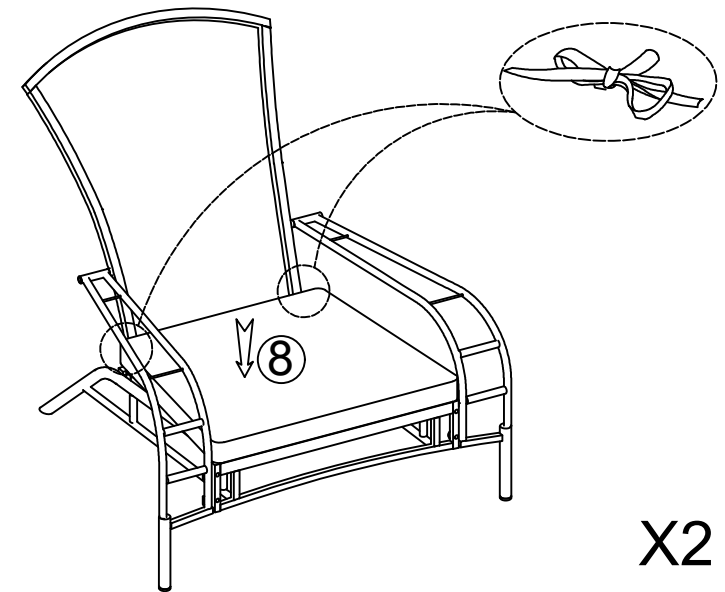

X2

STEP 4: Locate Cushion with Nut to finish.

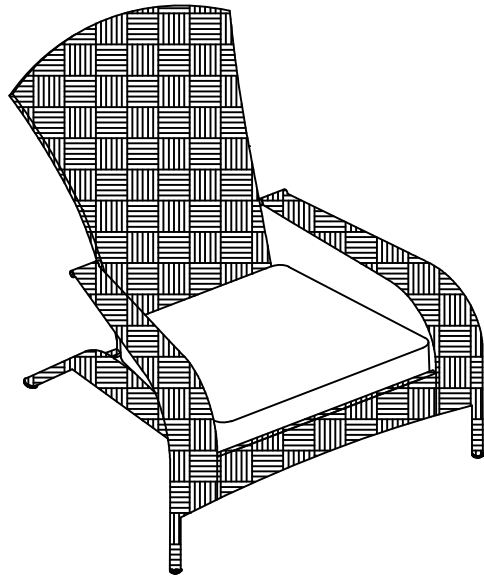

X2

STEP 5: Finish.

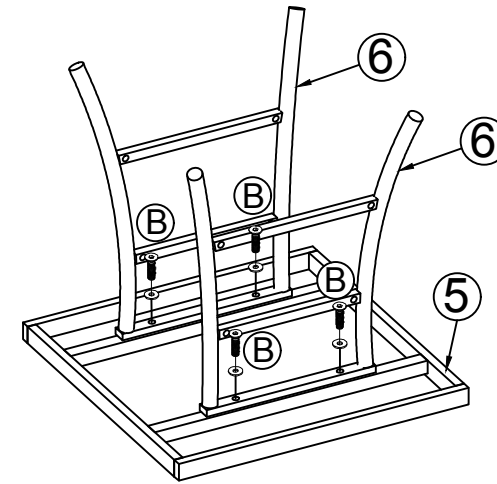

STEP 6: Connect Table Frame (5) & Leg Frame (6), tighten Allen Bolt (B), Flat Washer (E) with Allen Key (F).

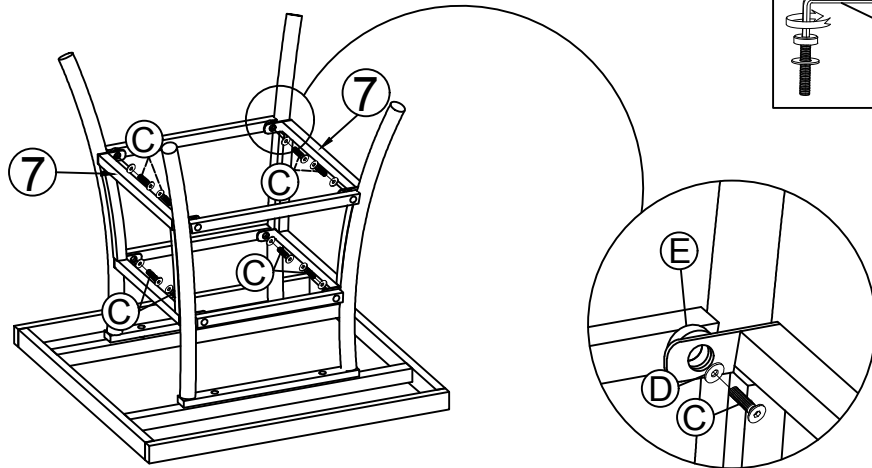

STEP 7: Connect the part from Step 6 & Side Frame Table (7), tighten Allen Bolt (C), Flat Washer (D), Washer (E) with Allen Key (F).

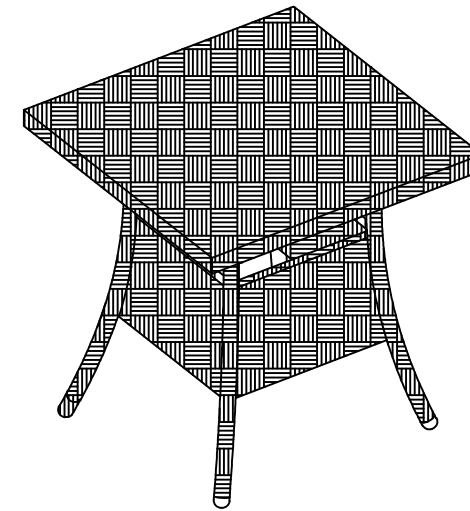

STEP 8: Finish.