

Assembly Instructions

Caution: You must read this before you proceed

Table

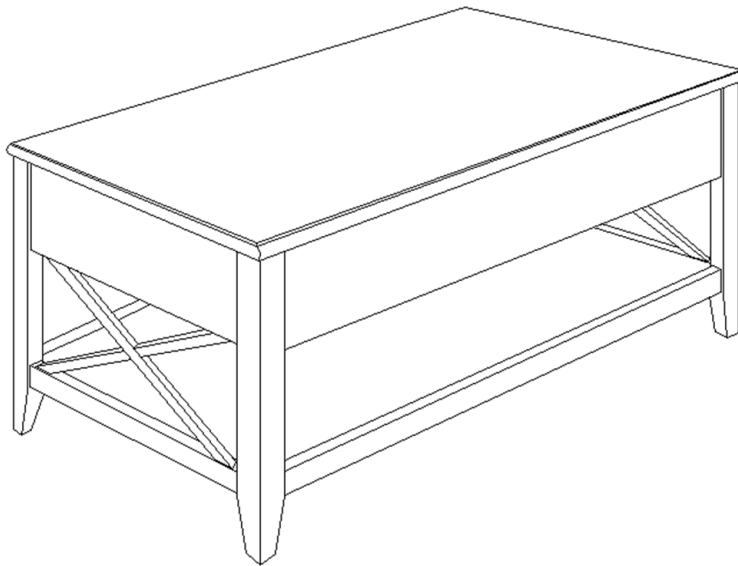



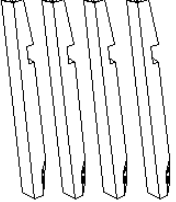
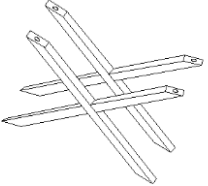

Part List

Label	Picture	Description	QTY
A	A line drawing of a rectangular table top, showing its thickness and a small notch on one side.	Table Top	1
B	A line drawing of a rectangular table base, showing its thickness and a small notch on one side.	Table Base	1

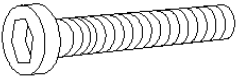
C		Table Leg	4
D		Connecting Rod	2

Hardware

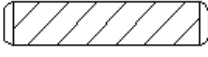
Label	Picture	Description	QTY
①		Bolt (M6*64mm)	13
②		Spring Washer (M6)	13
③		Washer (M6x16mm)	13
④		Allen Key (M4mm)	1
⑤		Dowel (Φ 8x30mm)	9

Assembly Preparation

Before Beginning Assembly:

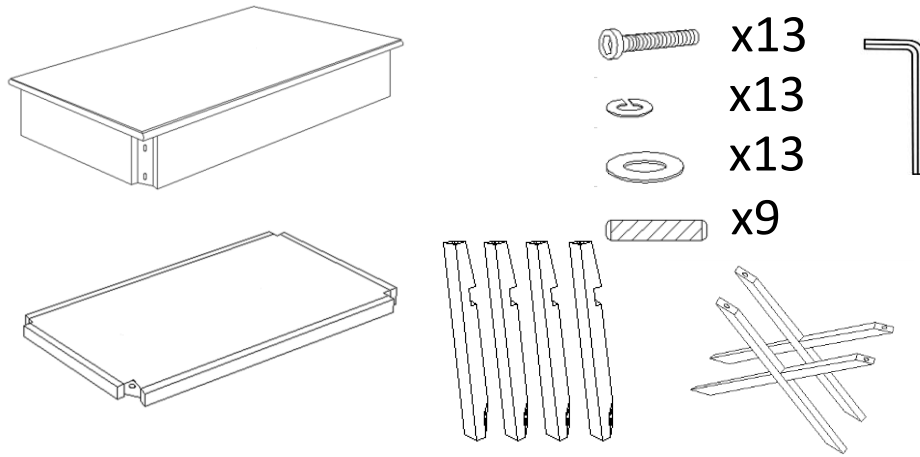

• Read instructions, cover to cover-



• Have 2 adults on hand for assembly-



• Do not assemble on flooring or carpet-



• Assemble on a clean non-marring surface (packing foam)-



• Save all packaging until finished-

Assembly Steps

Overview

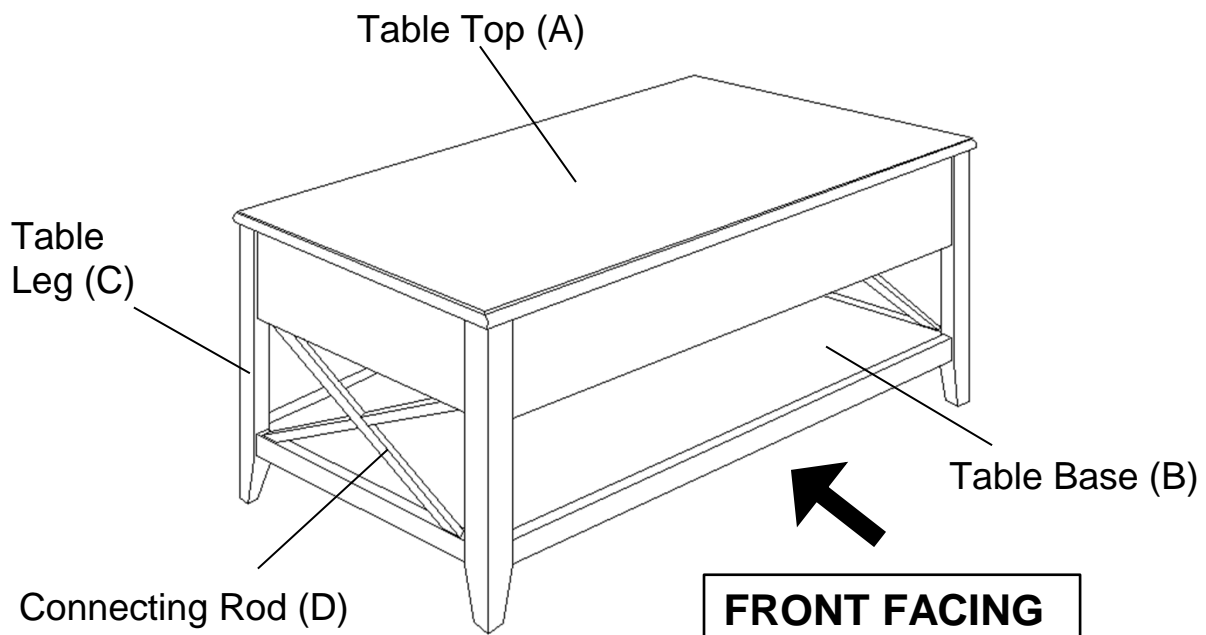

This Table has multiple parts and may require up to 30 minutes to assemble. To give you an overview of the Table parts, the above picture is to help you put the various parts into perspective. Please read through the instructions below to familiarise yourself with the parts and steps before assembly.

Step 1

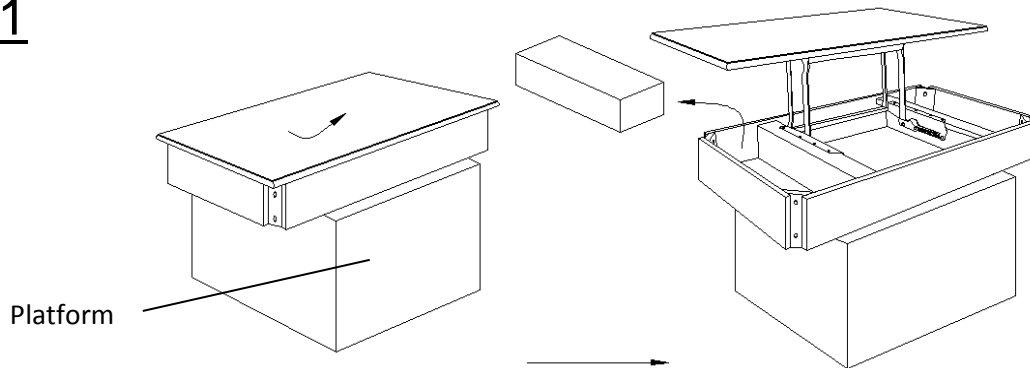

Please place the product on a platform.
Lift up on the top of the Coffee Table to open, then take out inner carton.

Step 2

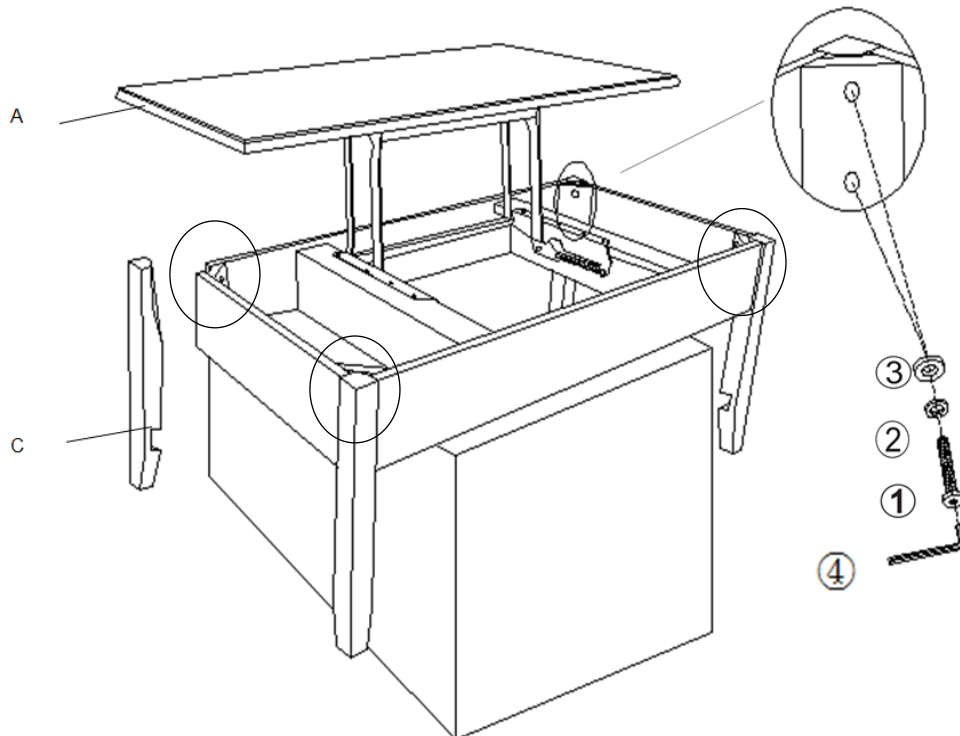

Attach Table Legs(C) to Table Top(A) using Bolts(①), Spring Washers(②), and Washers(③) with Allen Key(④).
Do not fully tighten the Bolts.

Step 3

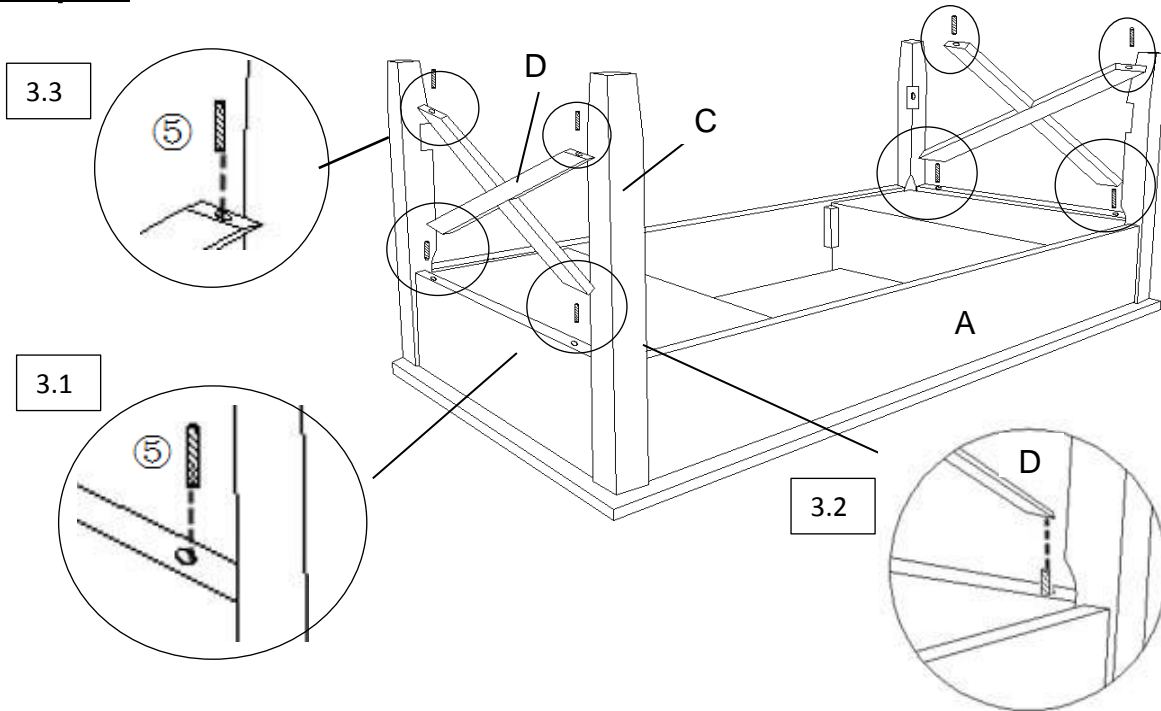

Place Table Top(A) facedown onto a clean, non-marring surface.

3.1) Insert Dowels(⑤) into mounting positions on Table Top(A).

3.2) Insert Connecting Rods(D) into the Dowels(⑤)

3.3) Insert Dowels(⑤) into mounting positions on Connecting Rods(D)

Step 4

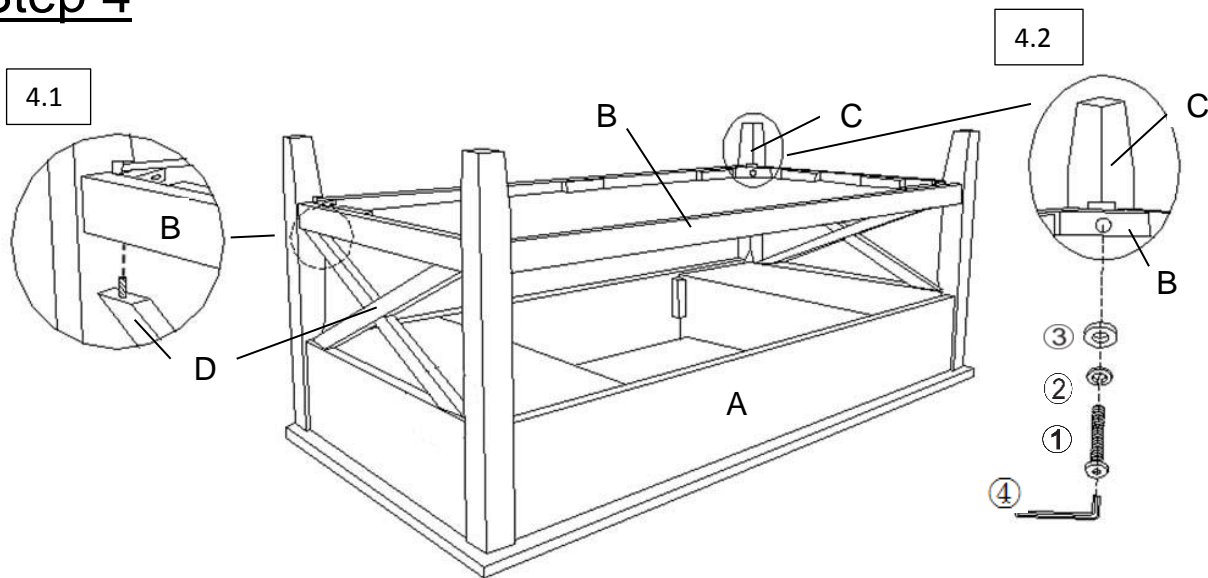

4.1) Insert Table Base(B) onto Dowels(⑤).

4.2) Insert Table Base(B) into Table Legs(C) mounting positions as shown above.

Attach Table Base(B) to Table Legs(C) using Bolts(①), Spring Washers(②), and Washers(③) with Allen Key(④).

Tighten all Bolts at all joints in a sequential manner.

Step 5

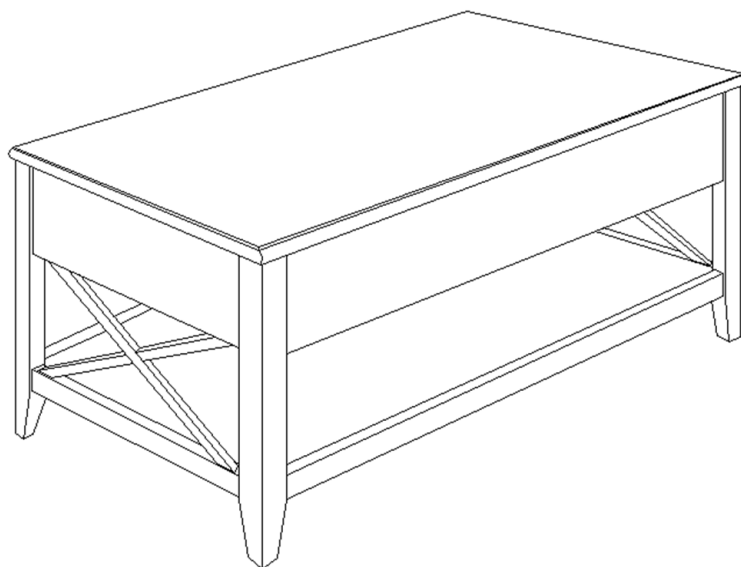

Your Table is ready for use.

This Table can only be used on a flat, level surface.

Care & Maintenance



- Do not put hot items directly on furniture surface



- Do not clean furniture with harsh cleansers or polish.



- Do not place furniture under direct sunlight.



- Do not place furniture near heating or cooling vents.



- Do not write on furniture without a padded barrier to protect the surface.



- Do not place furniture outside . For indoor use only .



- Not for commercial use. For residential use only .



- Stains may be removed with mild soap solution and damp cloth.



- Children should not climb or jump on the furniture.



- Dust and pick-up spills using a clean, non-colored, lint-free cloth .