

VEVOR

Affordable. Reliable. Home Improvement.

DAYBEDS

MODEL:YJX-BF-001

VEVOR

Affordable. Reliable. Home Improvement.

DAYBEDS

MODEL: YJX-BF-001

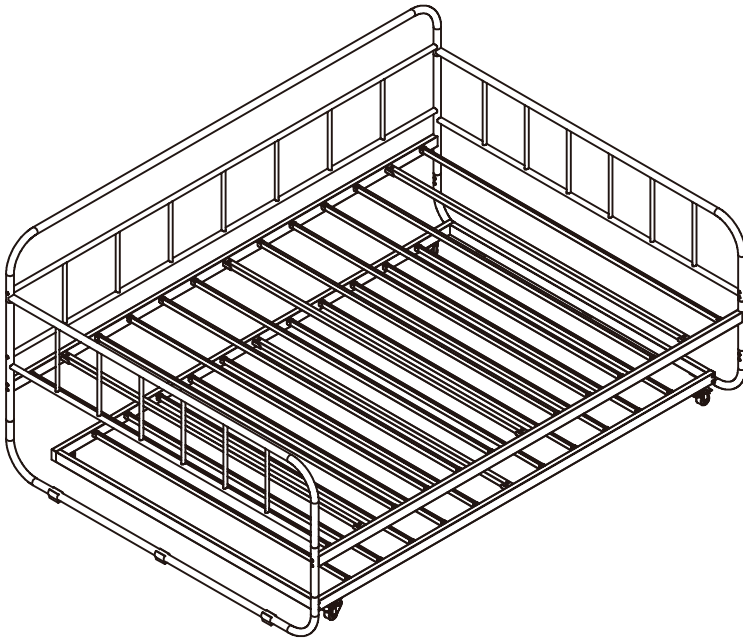

This is the original instruction, please read all manual instructions carefully before operating. VEVOR reserves a clear interpretation of our user manual. The appearance of the product shall be subject to the product you received. Please forgive us that we won't inform you again if there are any technology or software updates on our product.

SAFETY INSTRUCTIONS

WARNING:

Read this material before using this product. Failure to do so may result in serious injury.

Assembly precautions











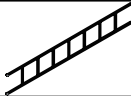







1. Assemble only according to these instructions. Improper assembly may create hazards.
2. Wear ANSI-approved safety goggles and heavy-duty work gloves during assembly.
3. Keep the assembly area clean and well-lit.
4. Keep bystanders out of the area during assembly.
5. Do not assemble if tired or when under the influence of alcohol, drugs or medication.
6. The product capabilities apply to properly and completely assembled products only.
7. Assemble on a flat, level, hard and smooth surface capable of safely supporting the Canopy Beds.
8. If possible, you can use power tools to make assembly easier.
9. For additional information regarding the parts listed in the following pages, please refer to the Assembly Diagram of this manual. Unwrap and separate all parts in a clean work area.

Use precautions

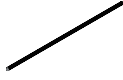
1. Do not exceed specified weight capacities.
2. Use only on a flat, level, hard, and smooth surface that can safely support a fully loaded Canopy Beds.
3. Use as intended only.
4. Inspect before every use; do not use if parts are loose or damaged.

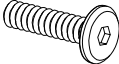
SAVE THIS MANUAL

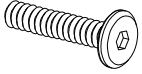
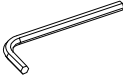
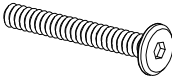
PARTS LIST

Item No.	Reference Image	Qty	Item No.	Reference Image	Qty
①		X1	⑧		X2
②		X1	⑨		X2
③		X1	⑩		X2
④		X1	⑪		X3
⑤		X2	⑫		X1
⑥		X2	⑬		X10
⑦		X2	⑭		X10
A	 M8*15	X12	F		X2
B	 M8*30	X8	G		X2
C	 M8*40	X8	H	 M5	X1
D	 M8*50	X16	O		X1
E		X16			

EXPLODED VIEW

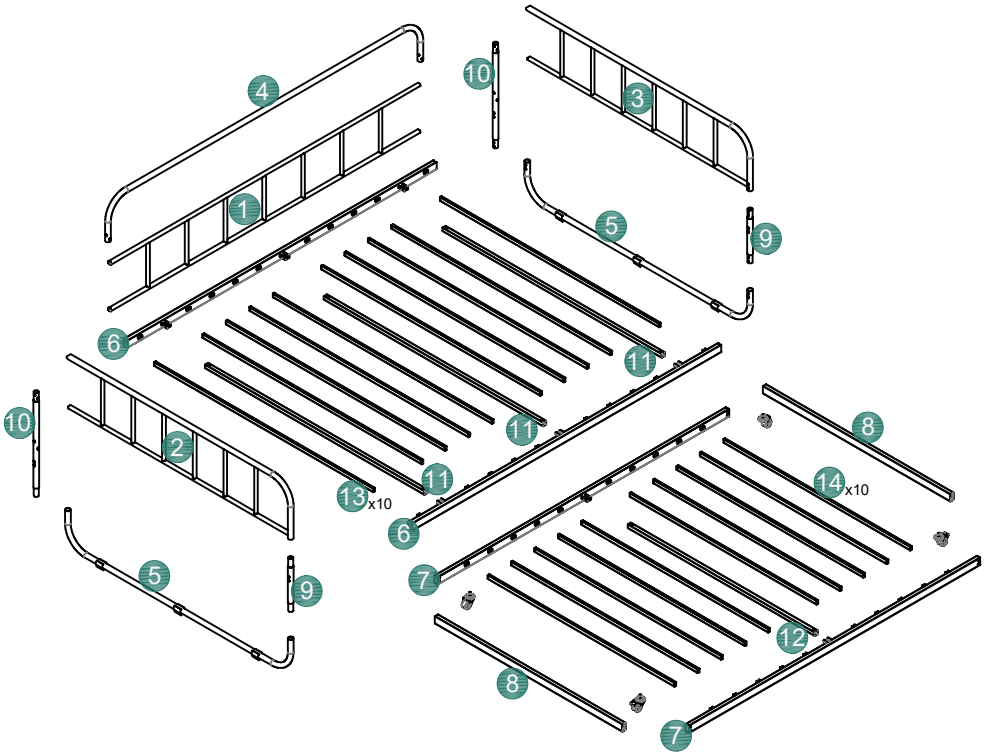

ASSEMBLY STEP

1



5 x2



9 x2



10 x2

M8*15



A x8

M5



H

Note: In order to facilitate installation, please lock the screws to 70% during installation.

Step 1

Step 2

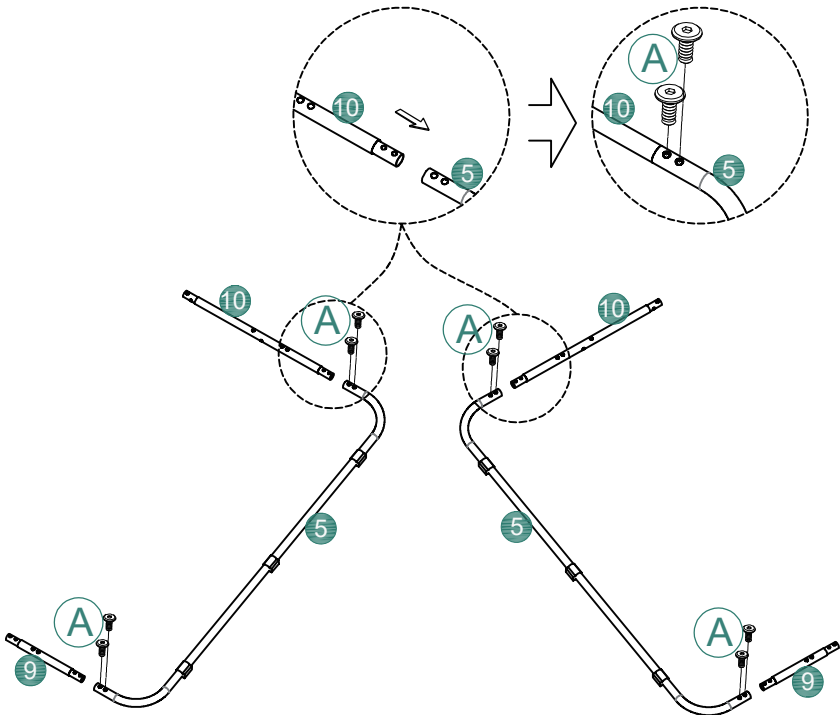

2



6 x2

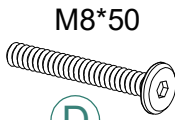

D x8



E x8

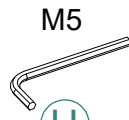

M5
H

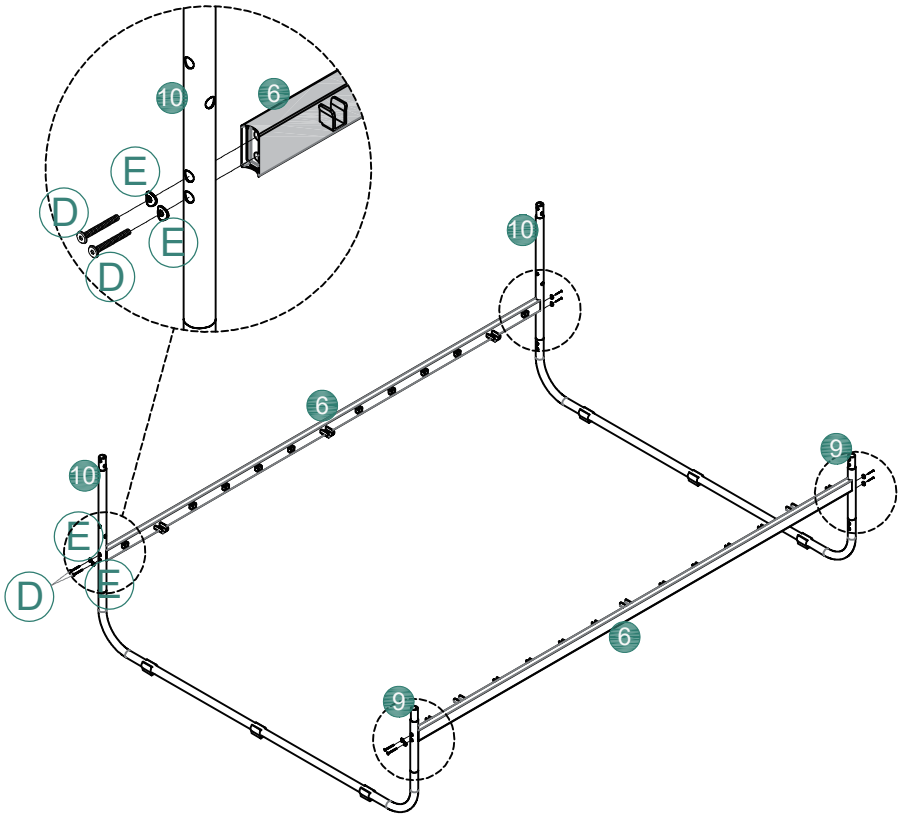

3

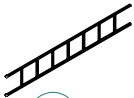

1 x1



4 x1

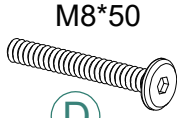

D x4



E x4

M5

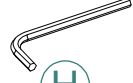

H

Step 1

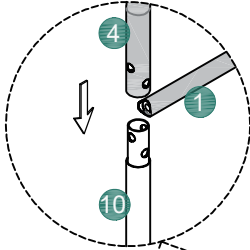

Step 2

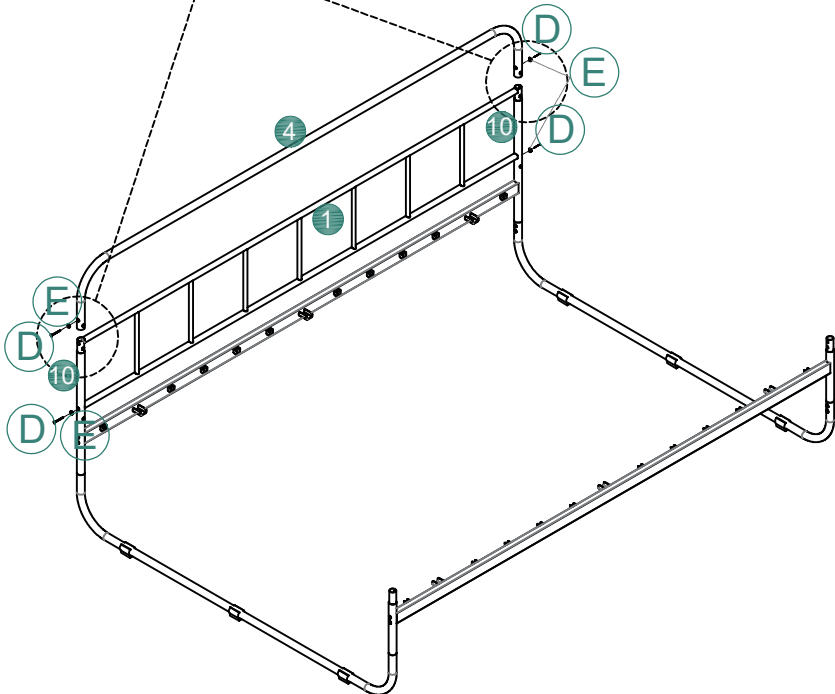
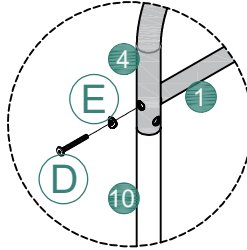

4

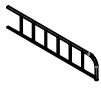

2 x1

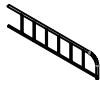

3 x1



A x4

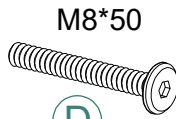

D x4



E x4

M5



H

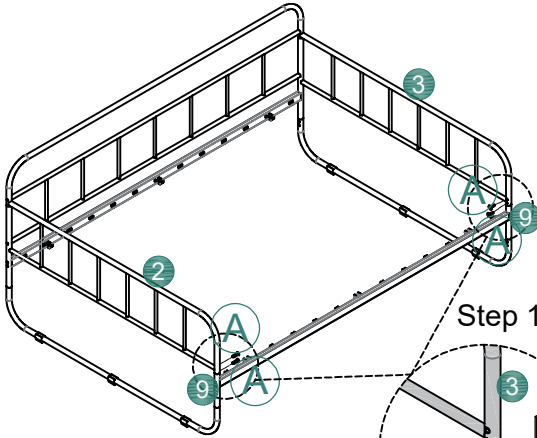

Step 1

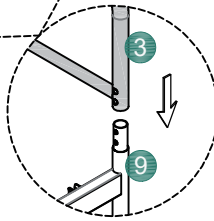

Step 2

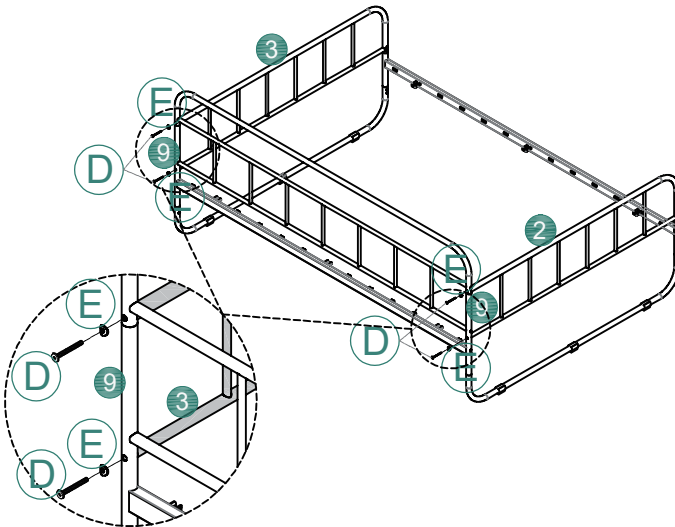
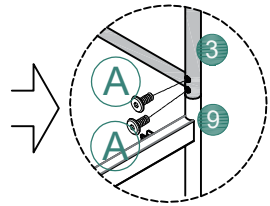

5



11 x3

M8*30



B x6

M5



H

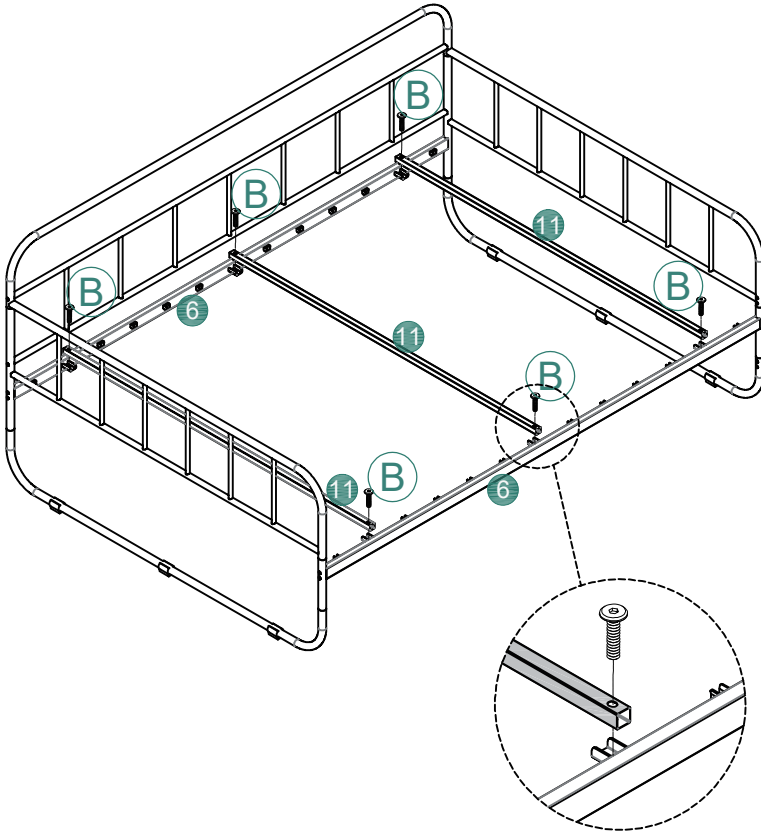

6

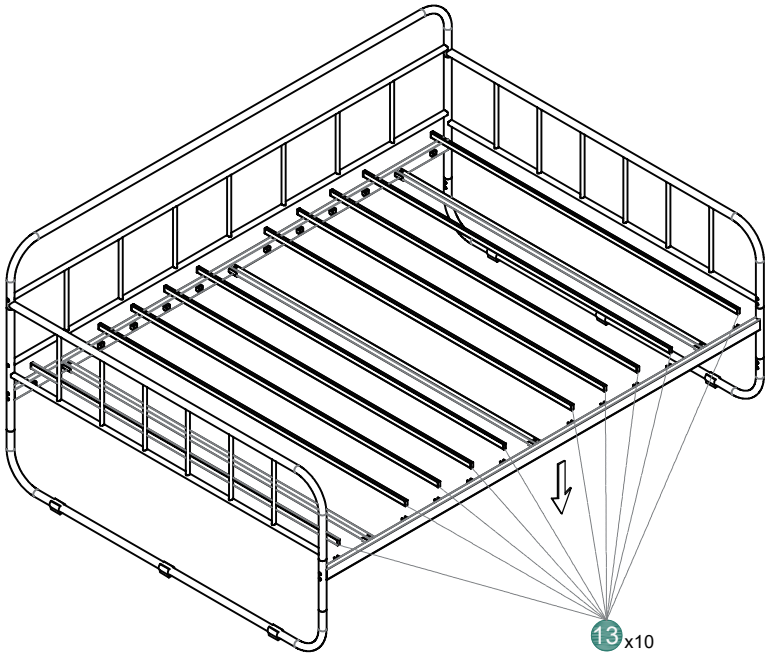
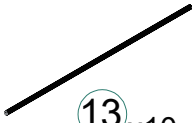

7



7 x2



8 x2



C x8

M5



H

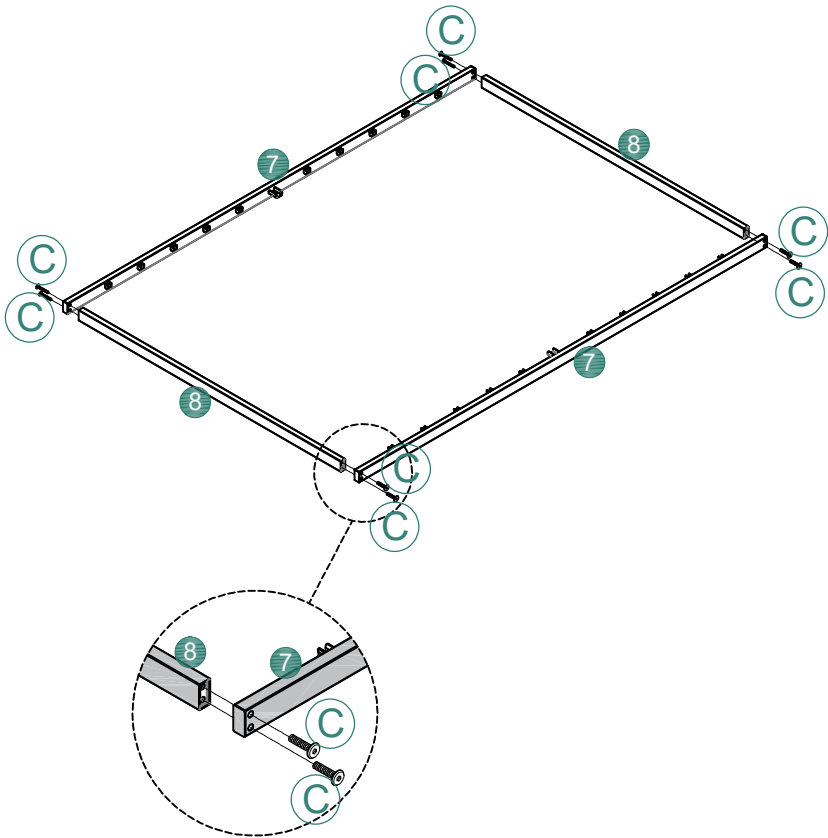

8



12 x1



14 x10



B x2

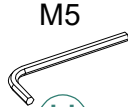

H

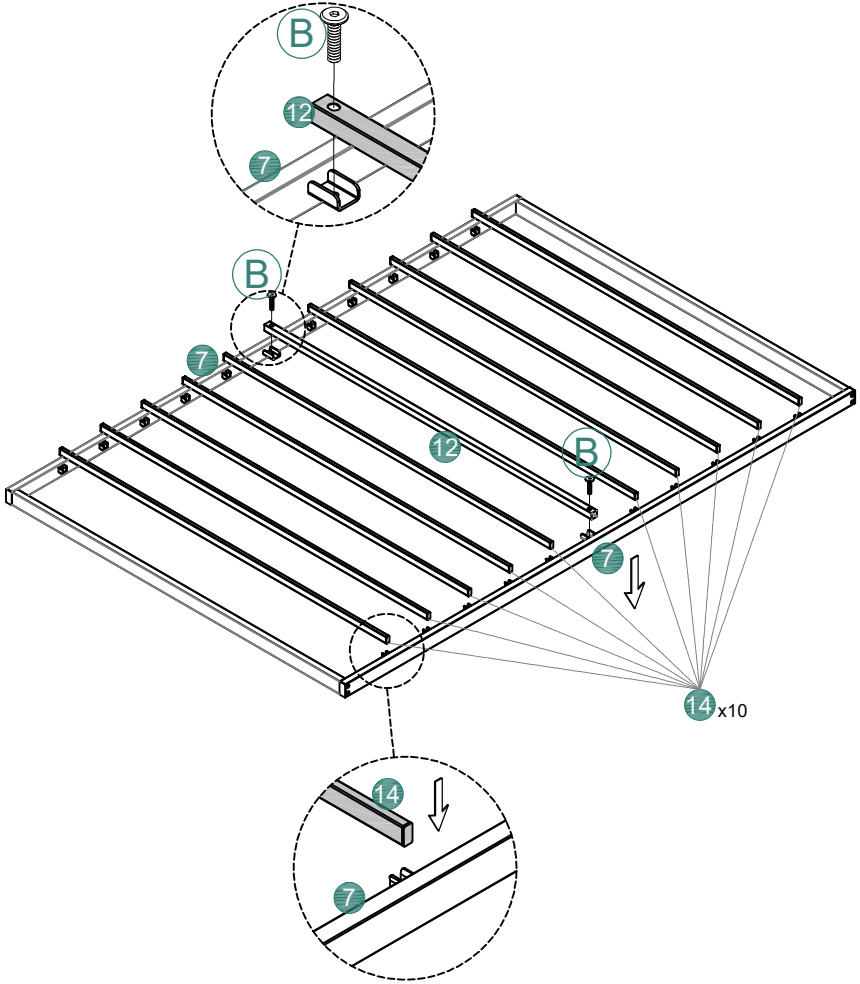

9



F x2



G x2



O

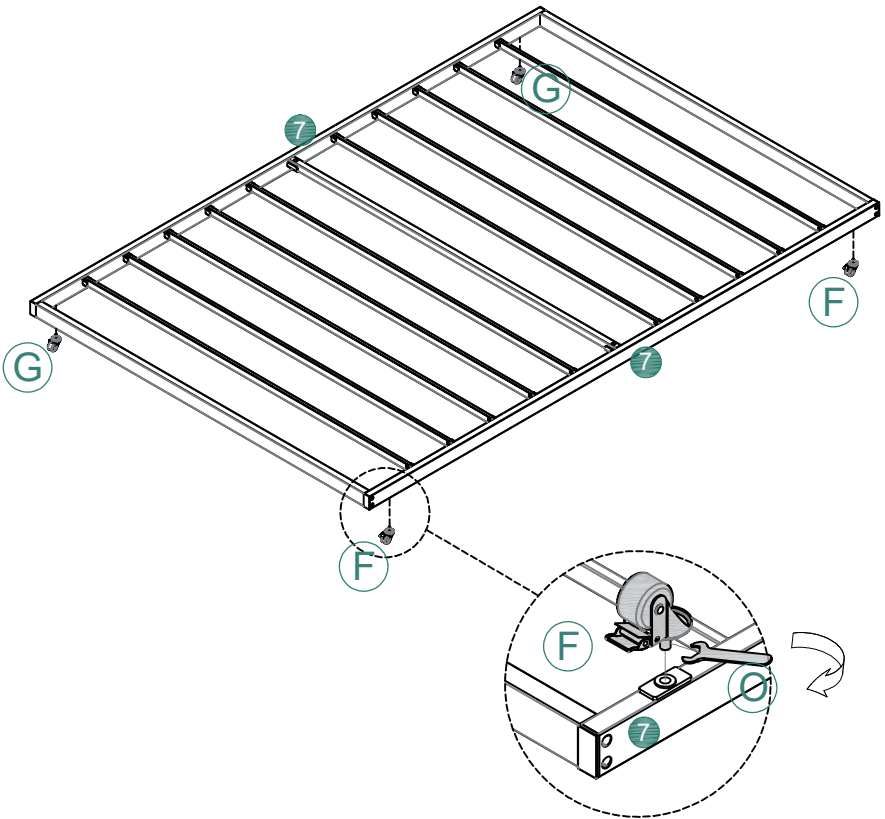

10

Assembly method A

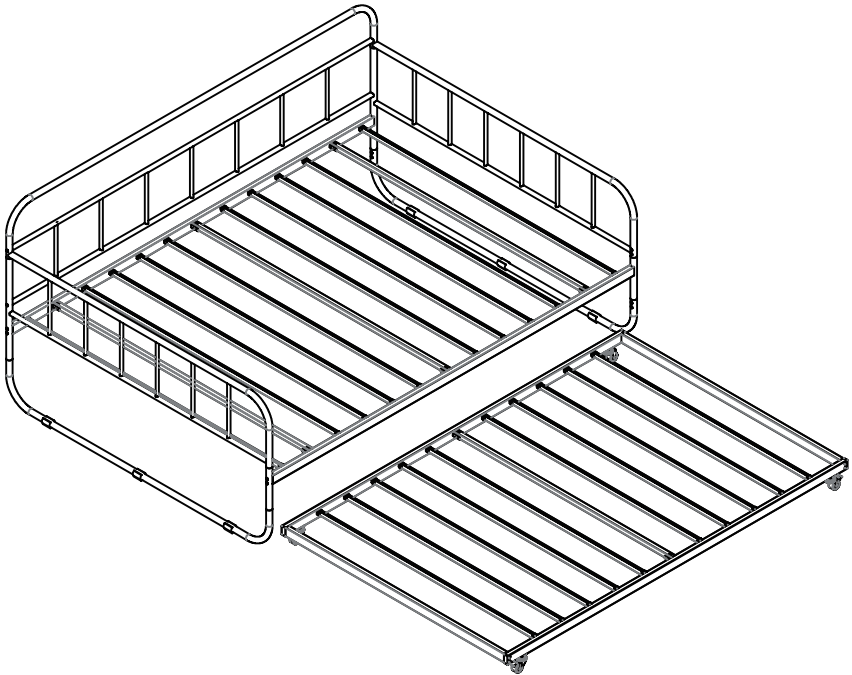

11

Check and tighten all screws

Assembly method B

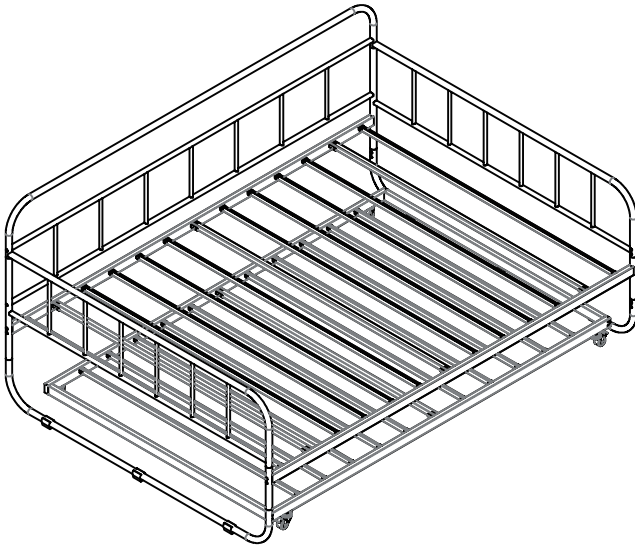

Manufacturer: Shanghaimuxinmuyeyouxiangongsi

Address: Shuangchenglu 803nong11hao1602A-1609shi, baoshanqu, shanghai 200000 CN.

Imported to AUS: SIHAO PTY LTD. 1 ROKEVASTREETEASTWOOD
NSW 2122 Australia

Imported to USA: Sanven Technology Ltd. Suite 250, 9166 Anaheim
Place, Rancho Cucamonga, CA 91730

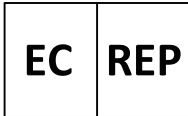

E-CrossStu GmbH
Mainzer Landstr.69, 60329 Frankfurt am Main.



YH CONSULTING LIMITED.
C/O YH Consulting Limited Office 147, Centurion
House, London Road, Staines-upon-Thames, Surrey,
TW18 4AX



VEVOR

Affordable. Reliable. Home Improvement.

TAGESBETTEN

MODELL: YJX-BF-001

MODELL: YJX-BF-001

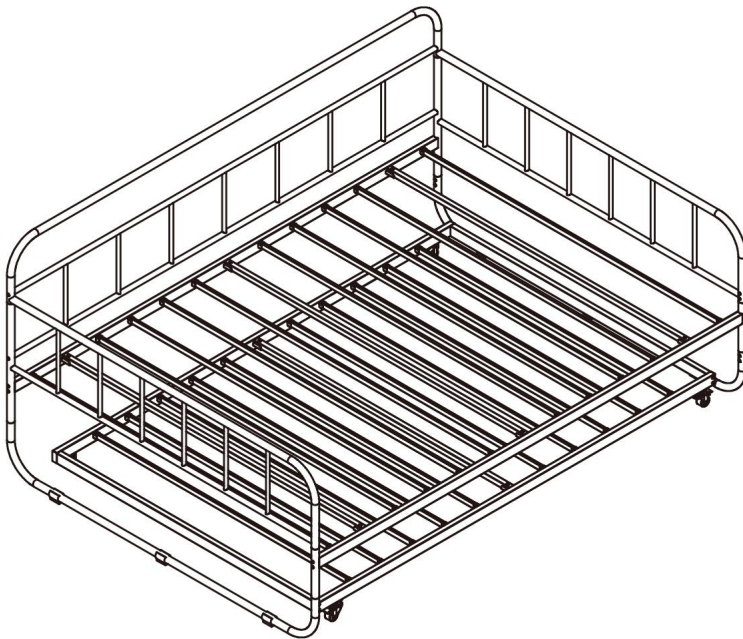

Dies ist die Originalanleitung. Bitte lesen Sie die gesamte Bedienungsanleitung vor der Inbetriebnahme sorgfältig durch. VEVOR behält sich die Auslegung der Bedienungsanleitung vor. Das Aussehen des Produkts kann von dem gelieferten Produkt abweichen. Wir bitten um Verständnis, dass wir Sie nicht erneut über etwaige Technologie- oder Software-Updates informieren werden.

SICHERHEITSHINWEISE

WARNUNG:

Lesen Sie diese Hinweise vor der Verwendung dieses Produkts. Andernfalls kann es zu schweren Verletzungen kommen.

Montagehinweise 1. Montieren

Sie die Teile nur gemäß dieser Anleitung. Unsachgemäße Montage kann Gefahren bergen.

2. Tragen Sie während der Montage eine ANSI-geprüfte Schutzbrille und robuste Arbeitshandschuhe.
3. Halten Sie den Montagebereich sauber und gut beleuchtet.
4. Halten Sie Unbeteiligte während der Versammlung vom Bereich fern.
5. Nicht montieren, wenn Sie müde sind oder unter dem Einfluss von Alkohol oder Drogen stehen. oder Medikamente.
6. Die Produkteigenschaften gelten nur für ordnungsgemäß und vollständig montierte Produkte.
7. Die Montage sollte auf einer ebenen, harten und glatten Oberfläche erfolgen, die die Baldachinbetten sicher tragen kann.
8. Falls möglich, können Sie Elektrowerkzeuge verwenden, um die Montage zu erleichtern.
9. Weitere Informationen zu den im Folgenden aufgeführten Teilen finden Sie
Siehe hierzu bitte die Montagezeichnung in diesem Handbuch. Packe alle Teile in einem sauberen Arbeitsbereich aus und trenne sie.











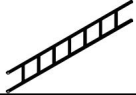









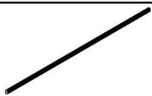

Beachten Sie die folgenden

Vorsichtsmaßnahmen: 1. Die angegebenen Gewichtskapazitäten dürfen nicht überschritten werden.

2. Nur auf einer ebenen, harten und glatten Oberfläche verwenden, die sicher haftet.
Unterstützung eines voll beladenen Baldachinbetts.
3. Nur bestimmungsgemäß verwenden.
4. Vor jedem Gebrauch prüfen; nicht verwenden, wenn Teile lose oder beschädigt sind.

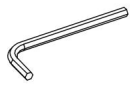
BEWAHREN SIE DIESES HANDBUCH AUF

TEILELISTE

Artikel NEIN.	Referenz Bild	Menge	Artikelnummer	Referenz Bild	Menge
①		X1	⑧		X2
②		X1	⑨		X2
③		X1	⑩		X2
④		X1	⑪		X3
⑤		X2	⑫		X1
⑥		X2	⑬		X10
⑦		X2	⑭ ○		X10
A	 M8*15	X12	F		X2
B	 M8*30	X8	G		X2
C	 M8*40	X8	H	 M5	X1
D	 M8*50	X16	O		X1
E		X16			

EXPLOSIONSZEICHNUNG

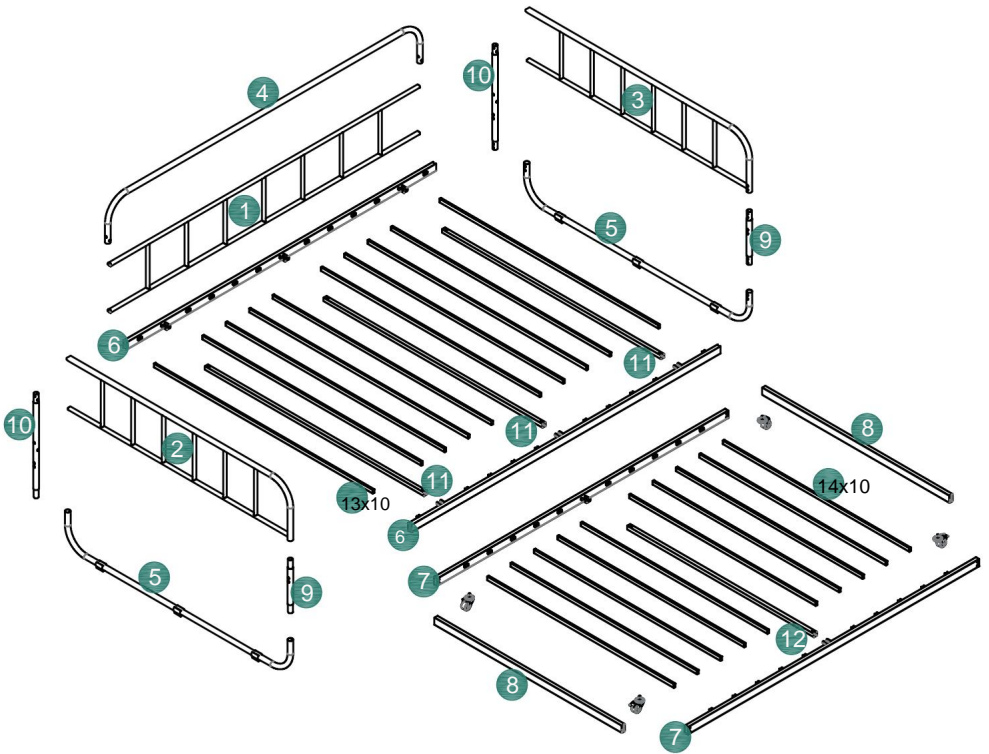

MONTAGESTRITT

1



5 x2



9 x2



10x2



M8*15
A x8

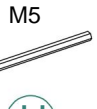

M5
H

Hinweis: Um die Bedienung zu vereinfachen

Bei der Montage die Schrauben bitte zu 70 % festziehen,
während der Installation.

Schritt 1

Schritt 2

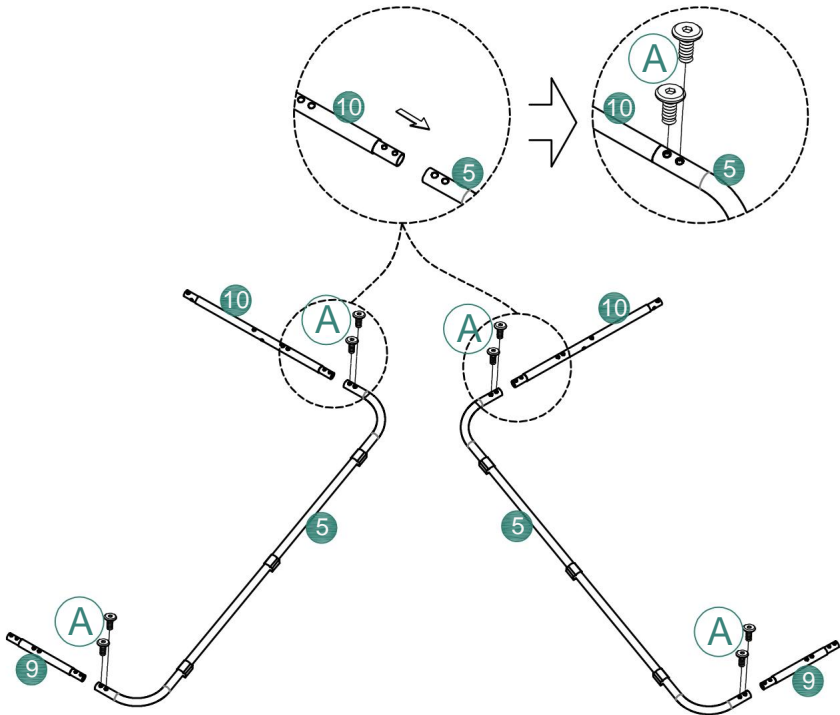

2



6
x2



D
x8



E
x8

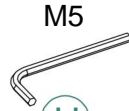

M5

H

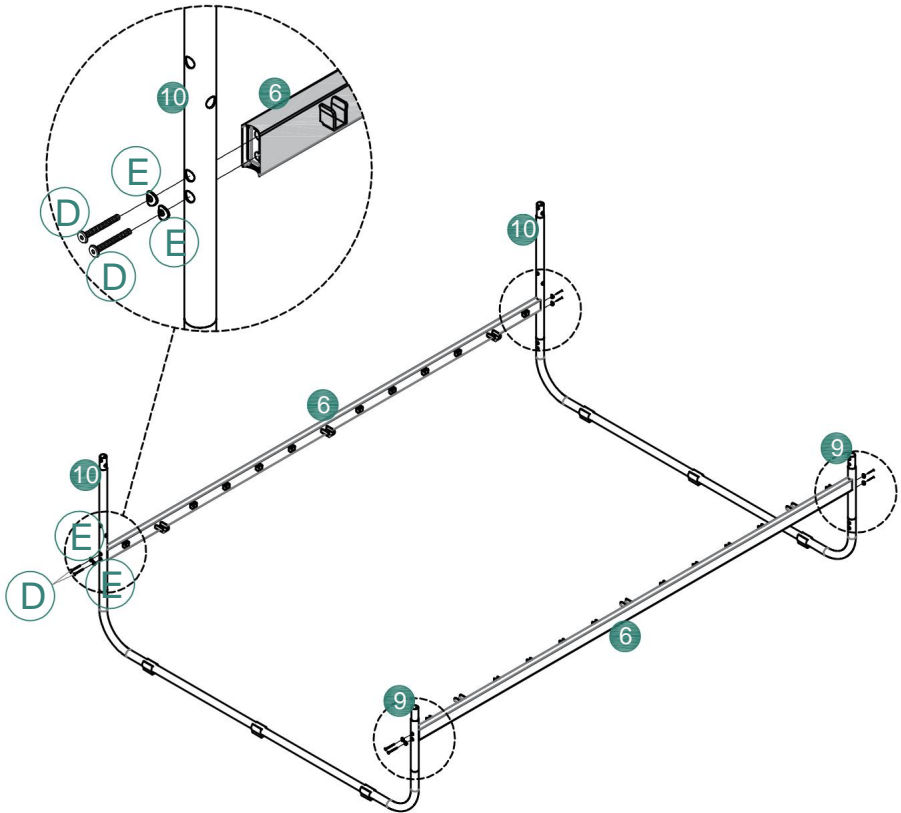

3



1 x1



4 x1



D x4



E x4

M5



H

Schritt 1

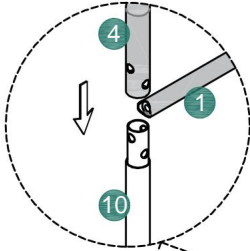

Schritt 2

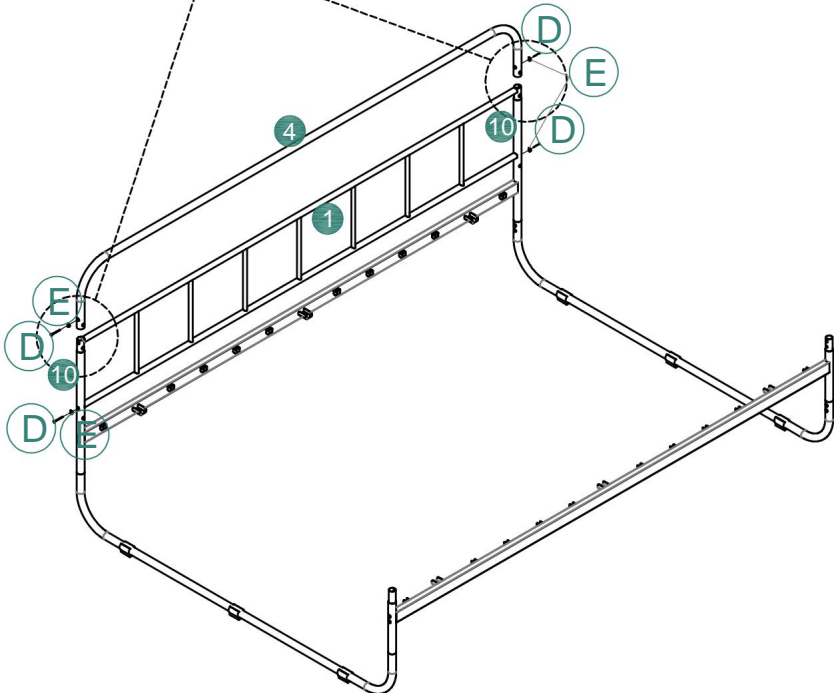
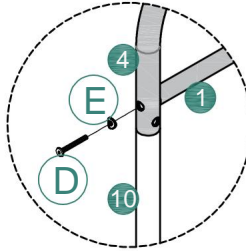

4

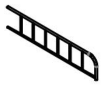

2 x1



3 x1

M8*15



A x4

M8*50



D x4



E x4

M5



H

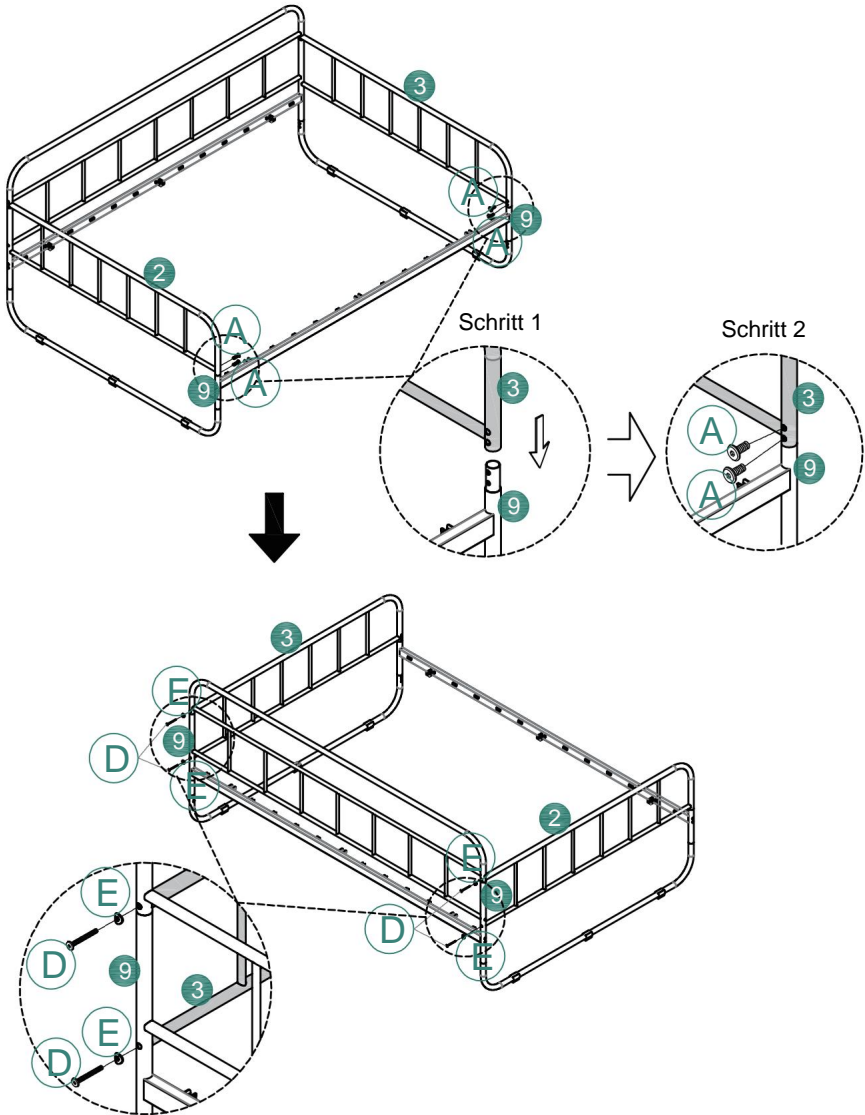

5



11x3

M8*30



B x6

M5



H

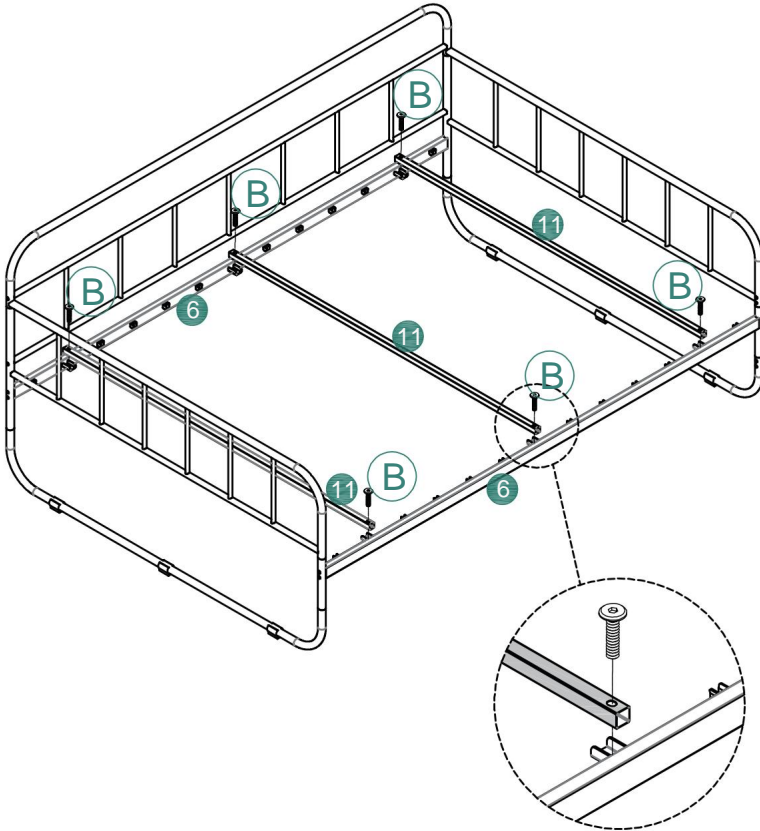

6

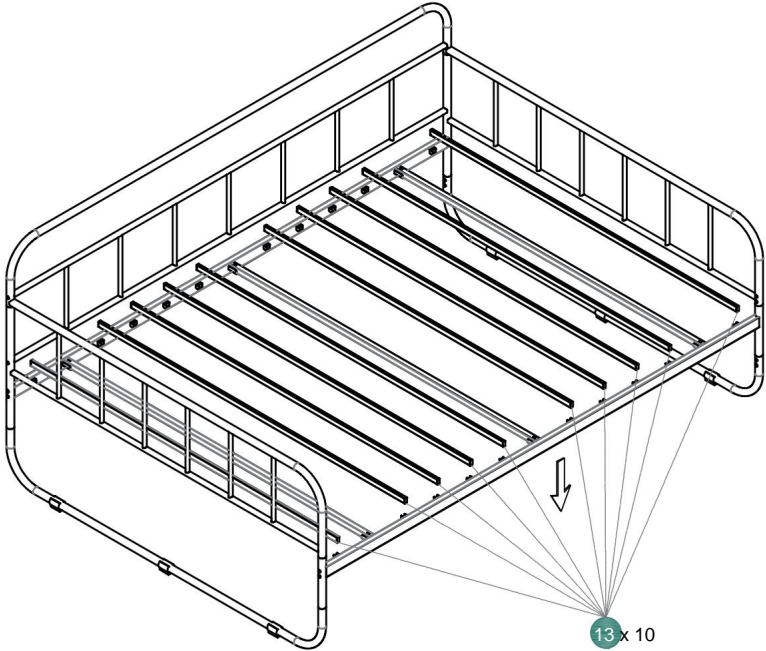
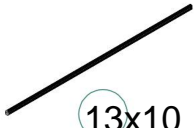

7



7 x2



8 x2



C x8

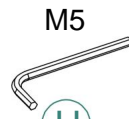

H

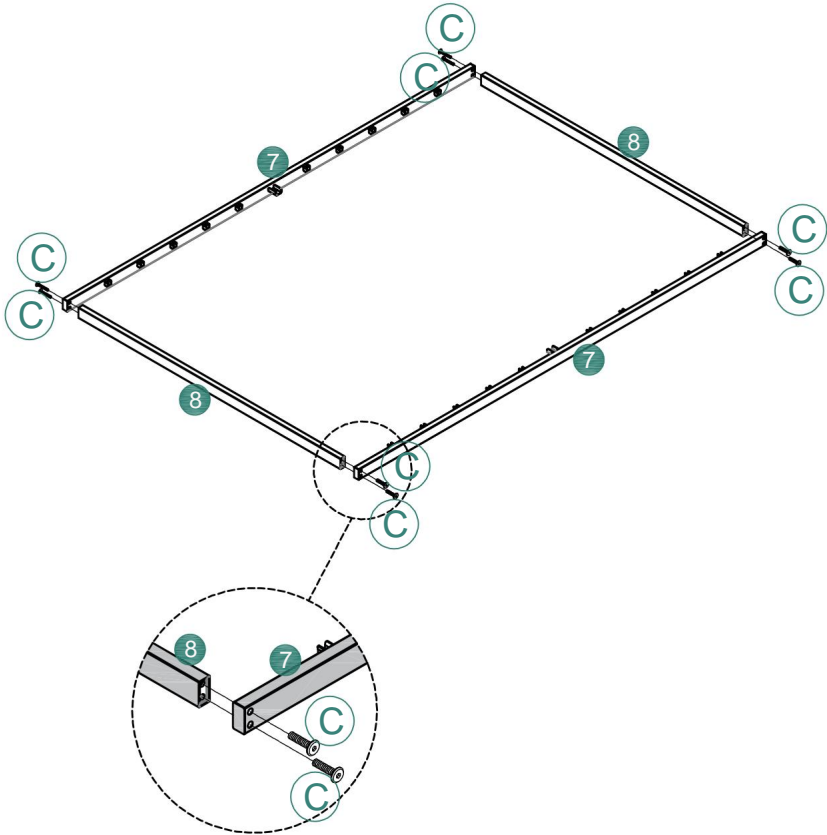

8



12x1



14x10



B
x2



H

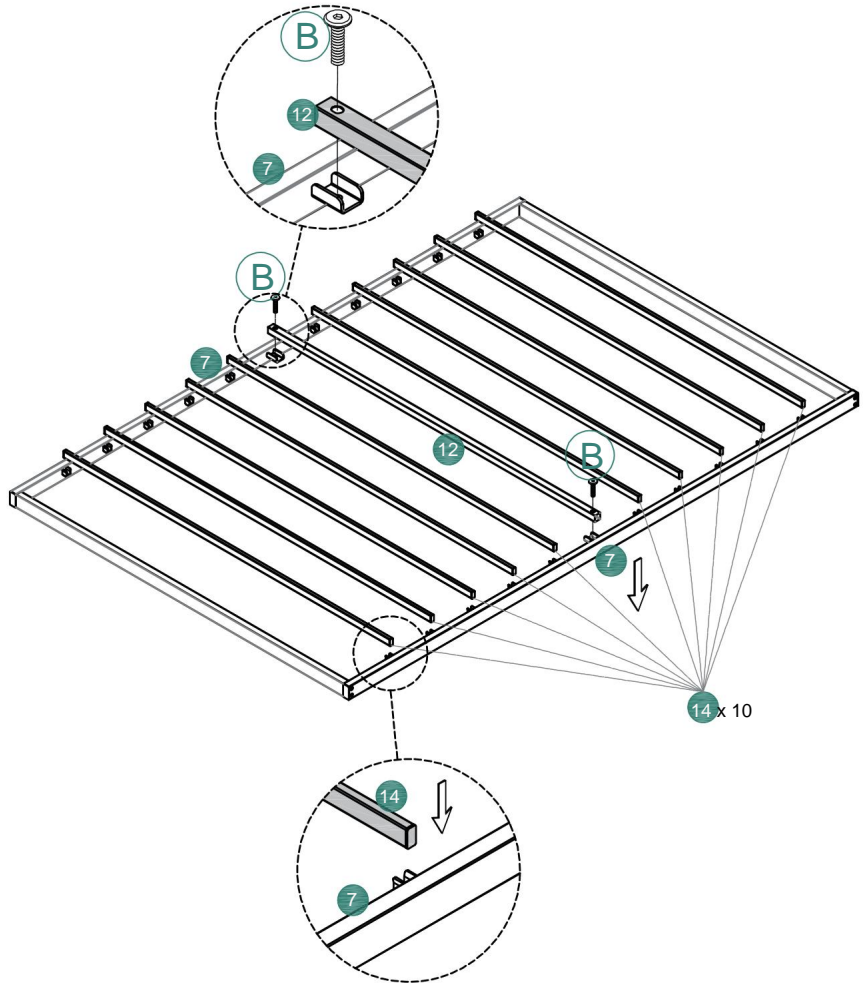

9



F x2



G x2 O O

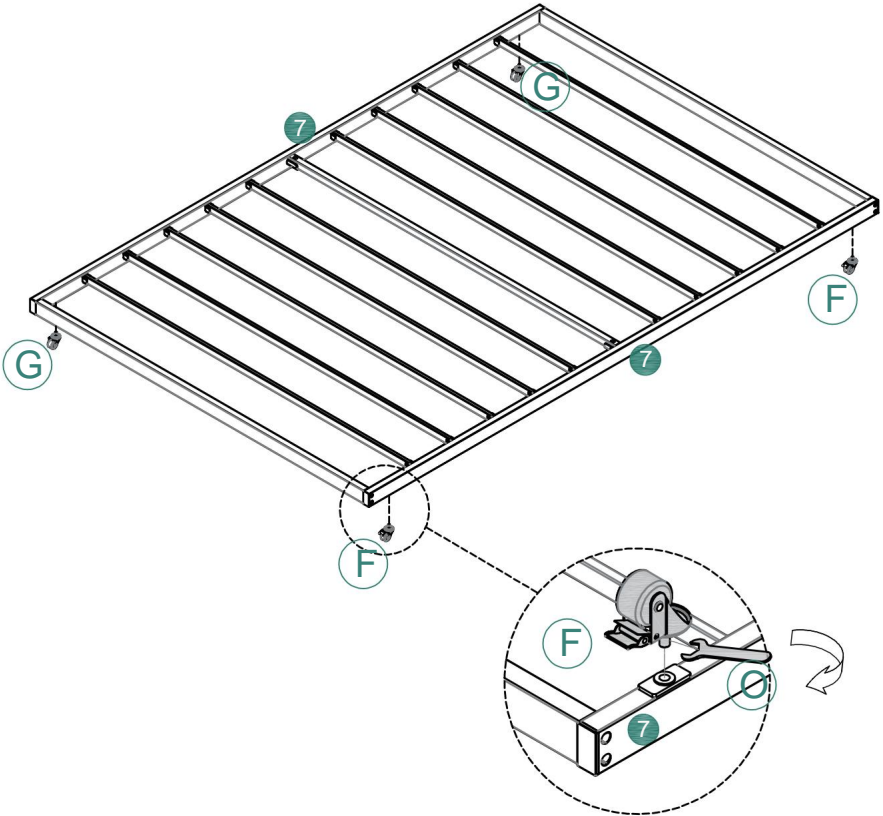

10

Montageverfahren A

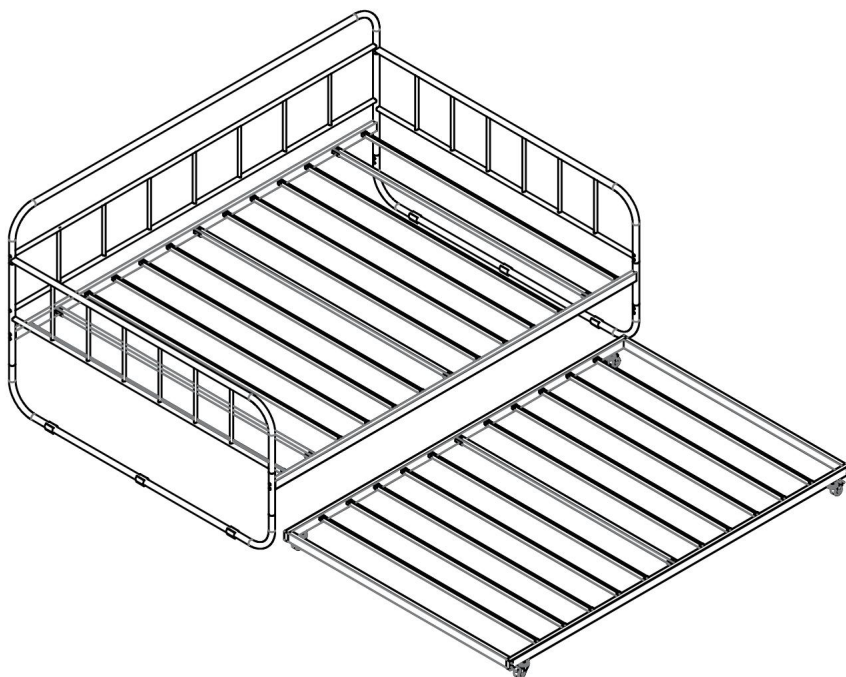

11

Prüfen und ziehen Sie alle Schrauben fest.

Montageverfahren B

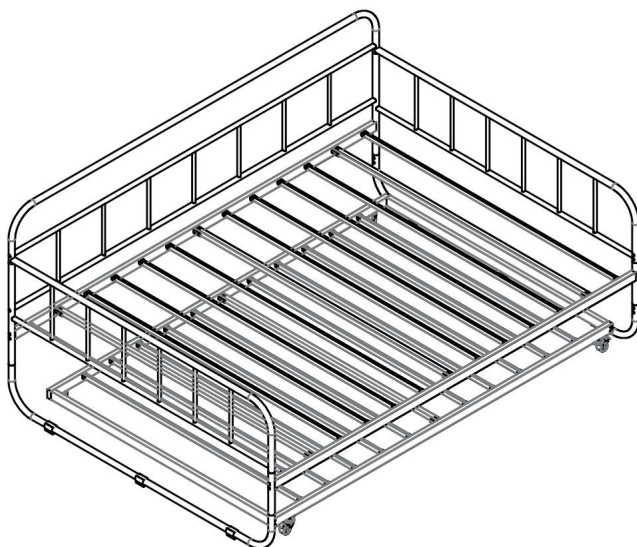

Hersteller: Shanghaimuxinmuyeyouxiangongsi Adresse:

Shuangchenglu 803nong11hao1602A-1609shi, baoshanqu, Shanghai 200000 CN.

Importiert nach Australien: SIHAO PTY LTD. 1 ROKEVASTREETEASTWOOD

NSW 2122 Australien.

Importiert in die USA: Sanven Technology Ltd. Suite 250, 9166 Anaheim Place, Rancho Cucamonga, CA 91730



E-CrossStu GmbH

Mainzer Landstr.69, 60329 Frankfurt am Main.



YH CONSULTING LIMITED.

C/O YH Consulting Limited, Büro 147, Centurion House,
London Road, Staines-upon-Thames, Surrey,
TW18 4AX



VEVOR

Affordable. Reliable. Home Improvement.

LIT DE JOUR

MODÈLE : YJX-BF-001

VEVOR

Affordable. Reliable. Home Improvement.

LIT DE JOUR

MODÈLE : YJX-BF-001

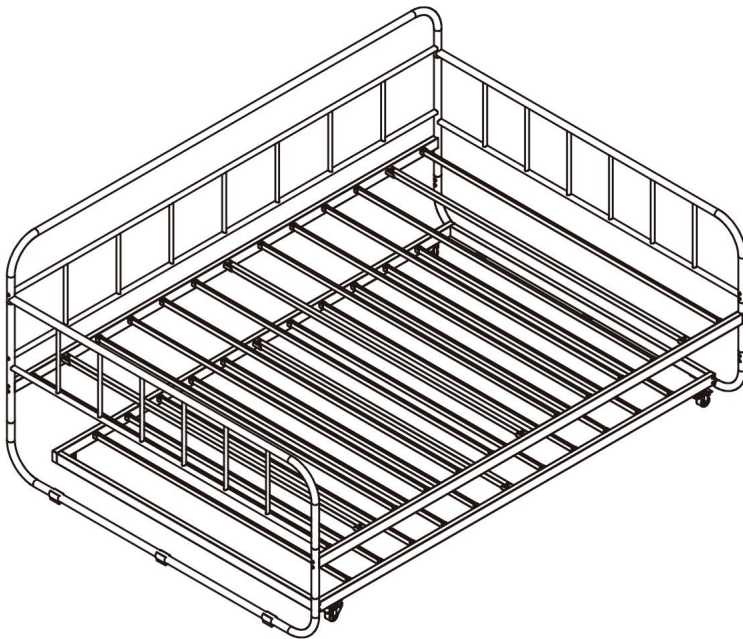

Voici le mode d'emploi original. Veuillez lire attentivement toutes les instructions du manuel avant utilisation. VEVOR se réserve le droit d'interpréter ce manuel à sa guise. L'apparence du produit que vous recevrez peut différer. Nous vous prions de nous excuser si nous ne vous informons pas des mises à jour techniques ou logicielles concernant notre produit.

CONSIGNES DE SÉCURITÉ

AVERTISSEMENT :

Veillez lire attentivement ce document avant d'utiliser ce produit. Le non-respect de cette consigne peut entraîner des blessures graves.

Précautions de montage 1.

Assemblez uniquement en suivant ces instructions. Un montage incorrect peut créer des risques.

2. Portez des lunettes de sécurité approuvées ANSI et des gants de travail robustes pendant l'assemblage.

3. Maintenez la zone de rassemblement propre et bien éclairée.

4. Tenez les curieux à l'écart de la zone pendant le rassemblement.

5. Ne vous rassemblez pas si vous êtes fatigué ou sous l'influence de l'alcool ou de drogues.
ou des médicaments.

6. Les capacités du produit s'appliquent uniquement aux produits correctement et entièrement assemblés.

7. Assembler sur une surface plane, de niveau, dure et lisse capable de supporter en toute sécurité les lits à canopée.

8. Si possible, vous pouvez utiliser des outils électriques pour faciliter l'assemblage.

9. Pour plus d'informations concernant les pièces énumérées dans la section suivante

Pour les pages, veuillez vous référer au schéma de montage de ce manuel. Déballez et séparez toutes les pièces dans un espace de travail propre.

Précautions d'emploi : 1.

Ne pas dépasser les capacités de poids spécifiées.











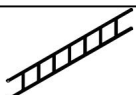











2. À utiliser uniquement sur une surface plane, de niveau, dure et lisse pouvant supporter sans danger supporter un lit à baldaquin entièrement chargé.

3. Utiliser uniquement comme prévu.

4. Inspecter avant chaque utilisation ; ne pas utiliser si des pièces sont desserrées ou endommagées.

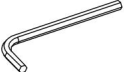
CONSERVEZ CE MANUEL

LISTE DES PIÈCES

Article Non.	Référence Image	Qté	Numéro d'article	Référence Image	Qté
①		X1	⑧		X2
②		X1	⑨		X2
③		X1	⑩		X2
④		X1	⑪		X3
⑤		X2	⑫		X1
⑥		X2	⑬		X10
⑦		X2	⑭ ○		X10
UN	 M8*15	X12	F		X2
B	 M8*30	X8	G		X2
C	 M8*40	X8	H	 M5	X1
D	 M8*50	X16	O		X1
E		X16			

VUE ÉCLATÉE

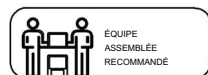
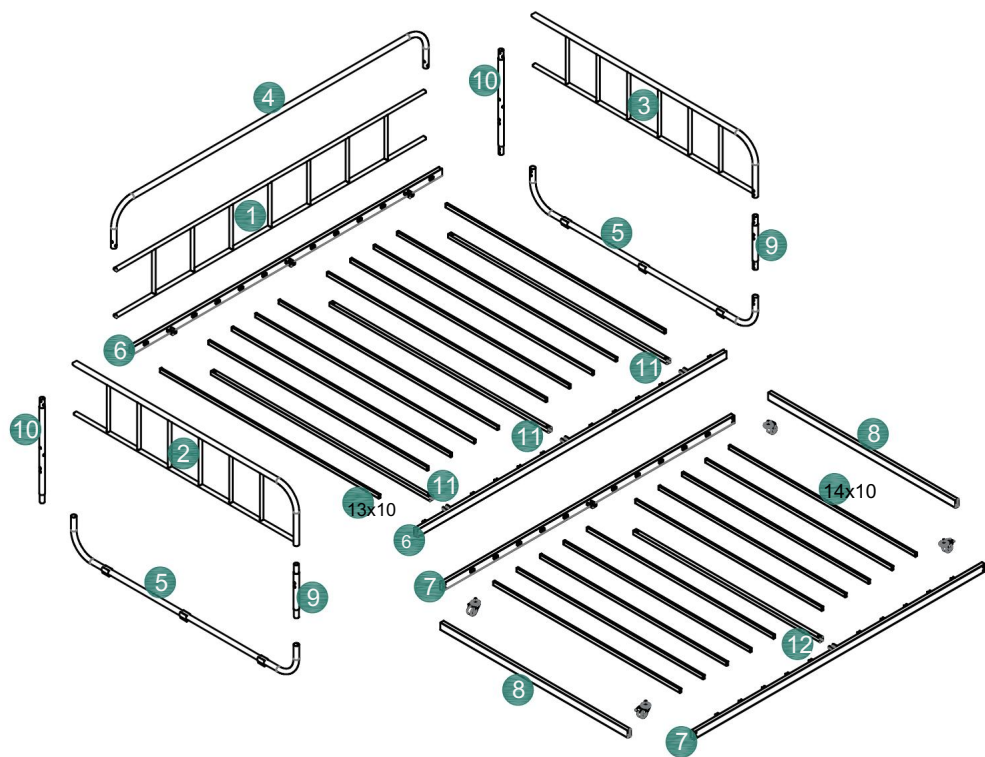

ÉTAPE D'ASSEMBLAGE

1



5 x2



9 x 2



10x2

M8*15



UN x8

M5



H

Remarque : Afin de faciliter

Lors de l'installation, veuillez serrer les vis à 70 %.

lors de l'installation.

Étape 1

Étape 2

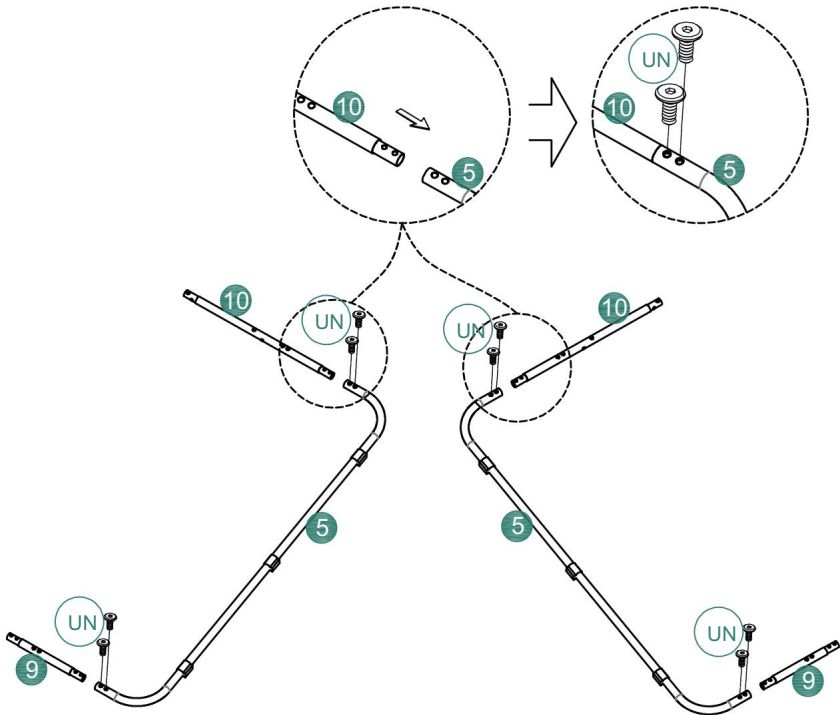

2



6 x 2

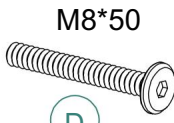

D x 8



E x 8



M5

H

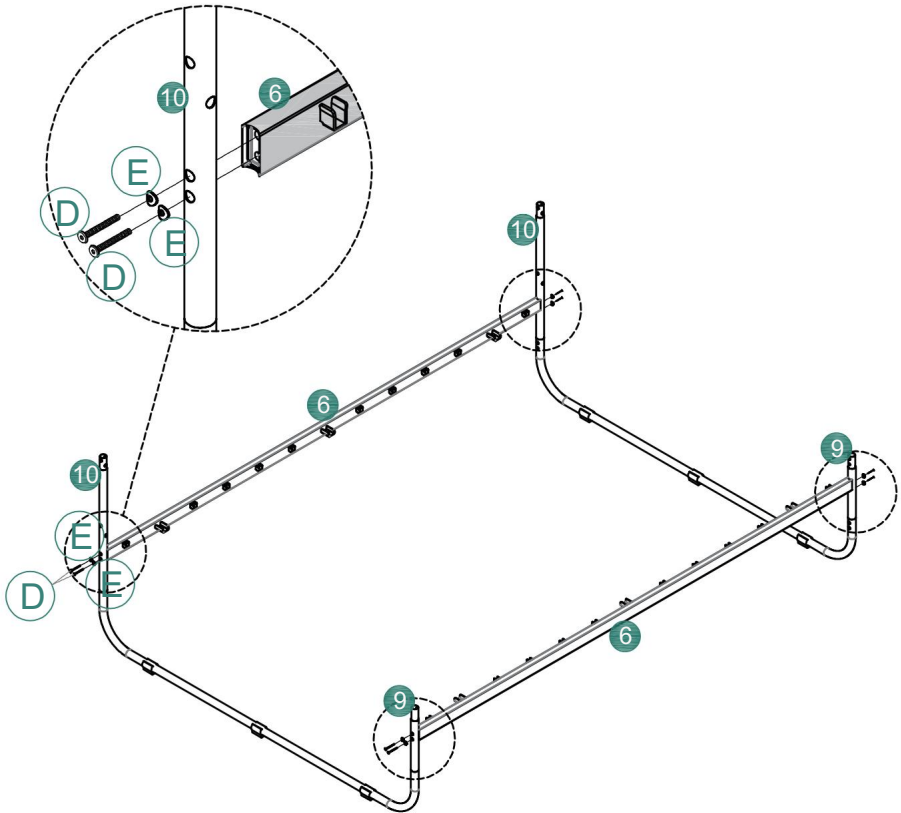

3



1 x1



4 x1

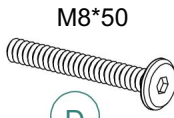

D x4



E x4

M5



H

Étape 1

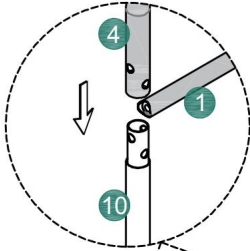

Étape 2

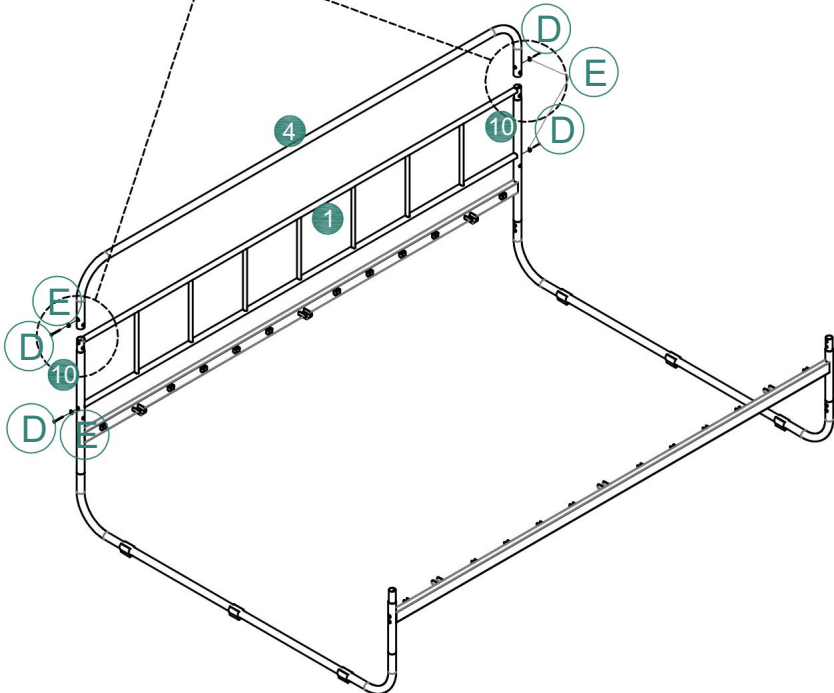
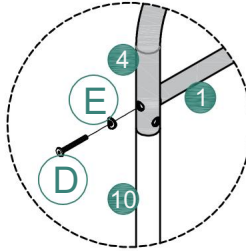

4



2 x1



3 x1

M8*15



A x4

M8*50



D x4



E x4

M5



H

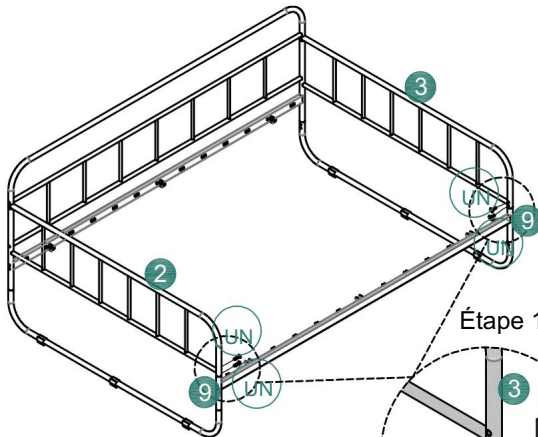

Étape 1

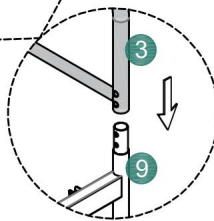

Étape 2

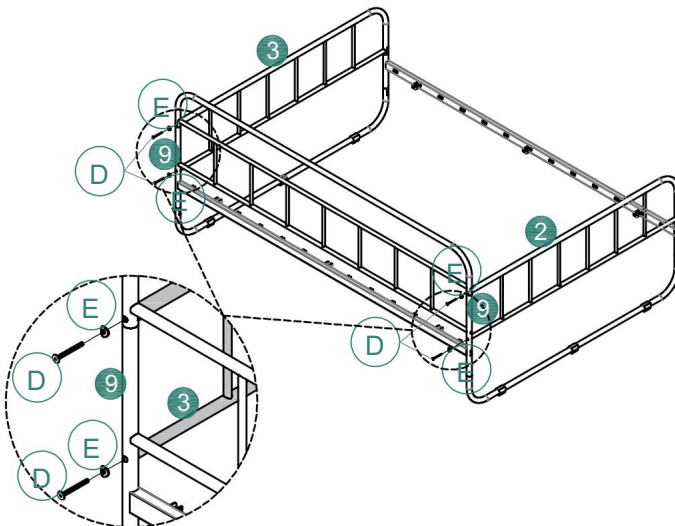
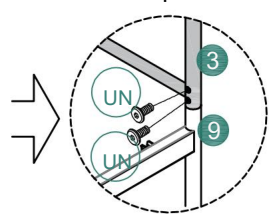

5



11x3

M8*30



B x6

M5



H

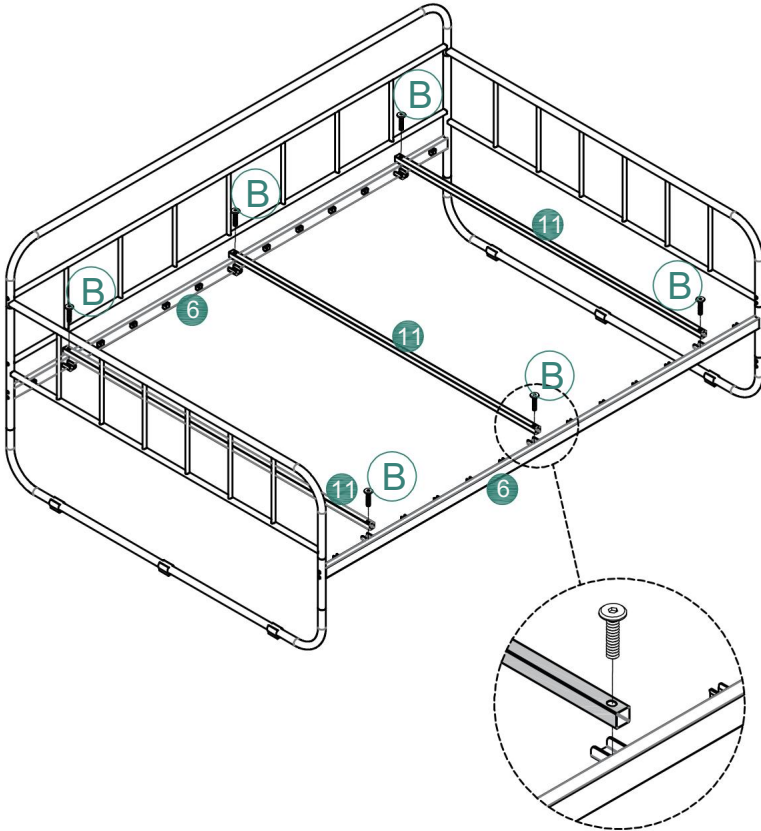

6

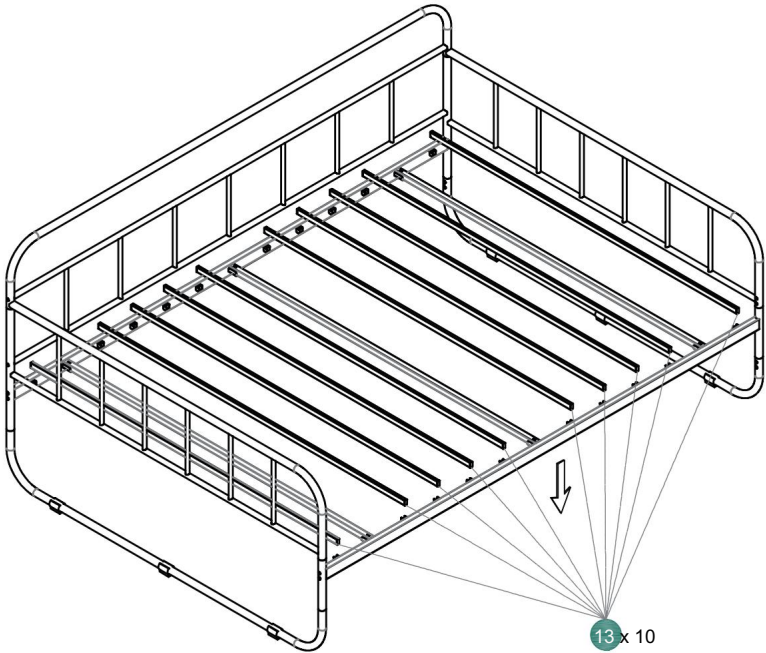
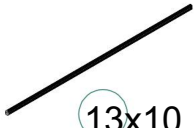

7



7 x 2



8 x 2



M8*40
C x 8

M5



H

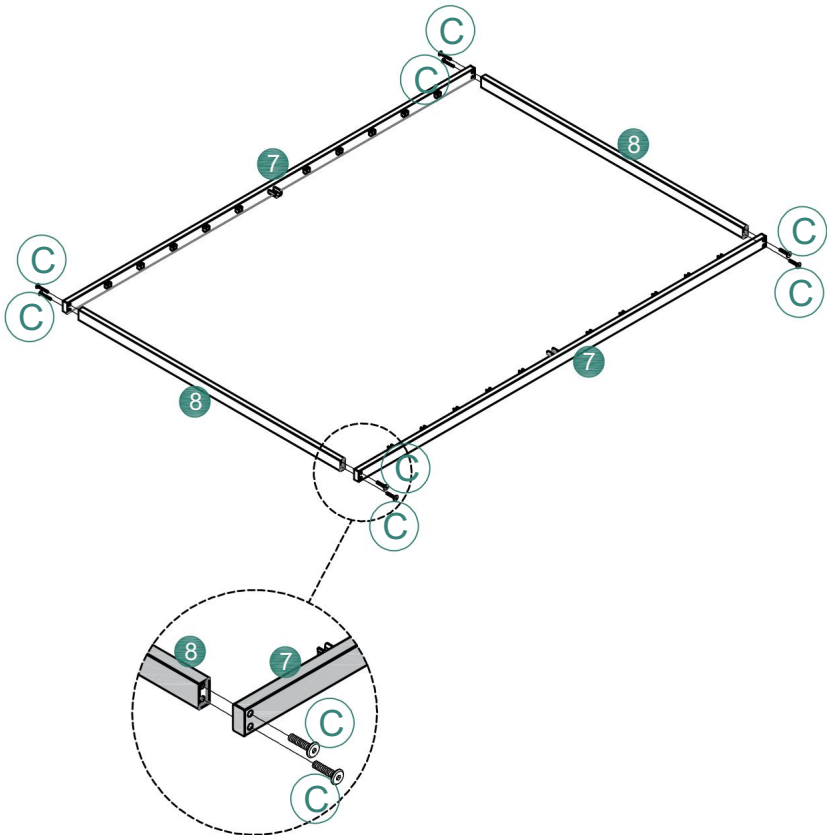

8



12x1



14x10



B x2



H

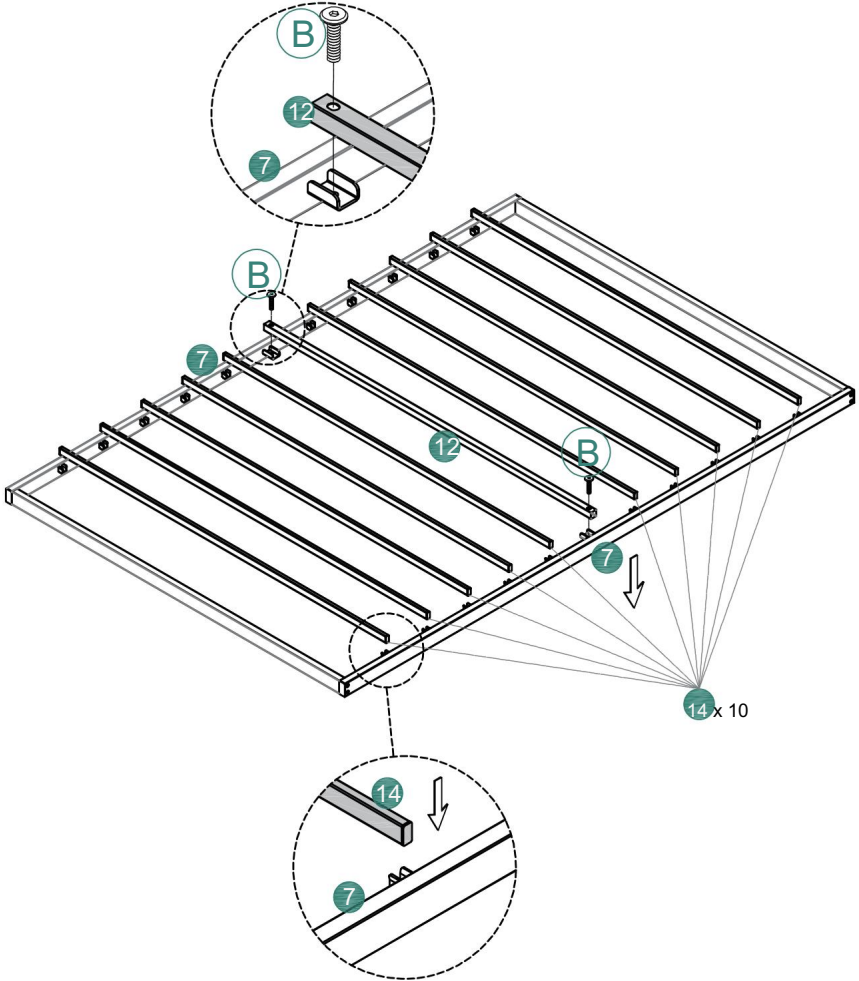

9



F x2



G x2 O O

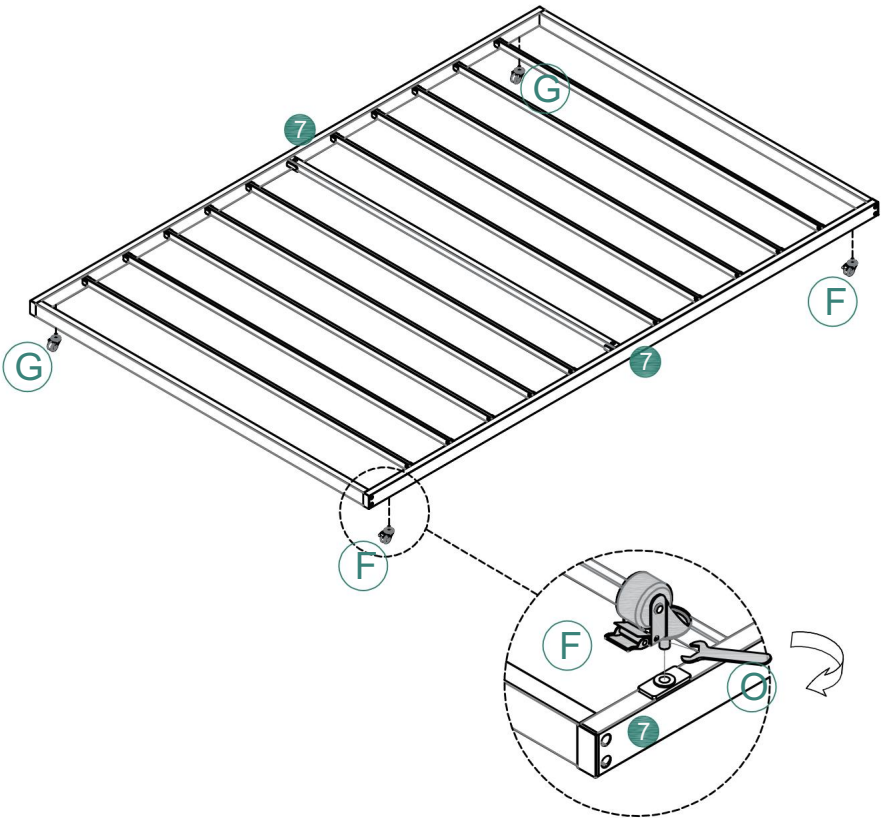

10

Méthode d'assemblage A

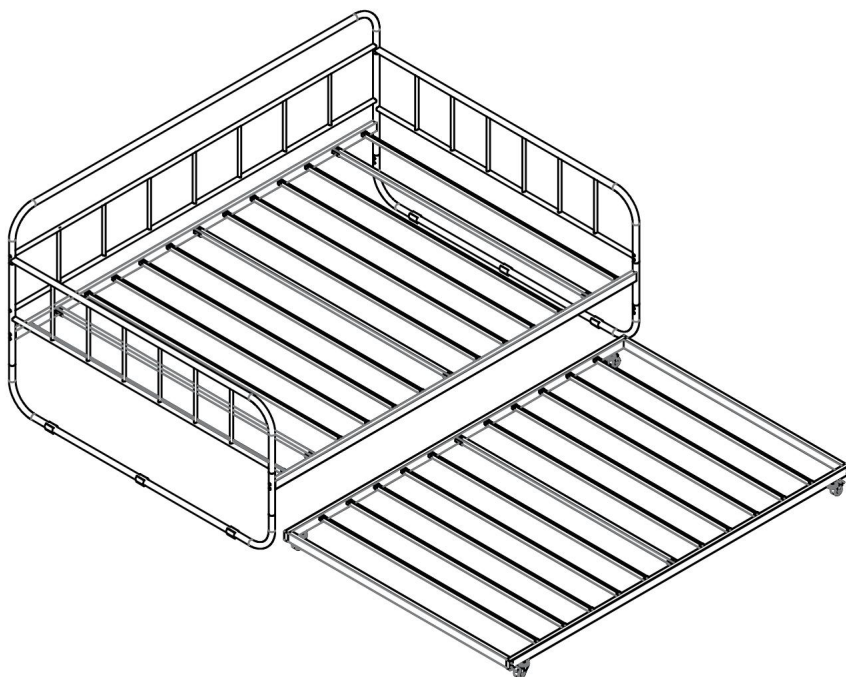

11

Vérifiez et serrez toutes les vis

Méthode d'assemblage B

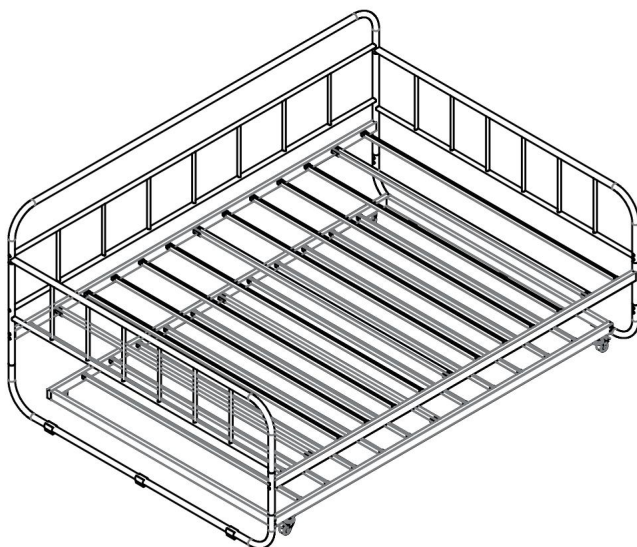

Fabricant : Shanghaimuxinmuyeyouxiangongsi Adresse :
Shuangchenglu 803nong11hao1602A-1609shi, baoshanqu, shanghai 200000 CN.

Importé en Australie : SIHAO PTY LTD. 1 ROKEVASTREEEESTWOOD

NSW 2122 Australie Importé

aux États-Unis : Sanven Technology Ltd. Suite 250, 9166 Anaheim Place, Rancho Cucamonga, CA
91730



E-CrossStu GmbH
Mainzer Landstr.69, 60329 Francfort-sur-le-Main.



YH CONSULTING LIMITÉE.
À l'attention de YH Consulting Limited, Bureau 147, Centurion
House, London Road, Staines-upon-Thames, Surrey,
TW18 4AX



VEVOR

Affordable. Reliable. Home Improvement.

Dagbedden

MODEL: YJX-BF-001

VEVOR

Affordable. Reliable. Home Improvement.

Dagbedden

MODEL: YJX-BF-001

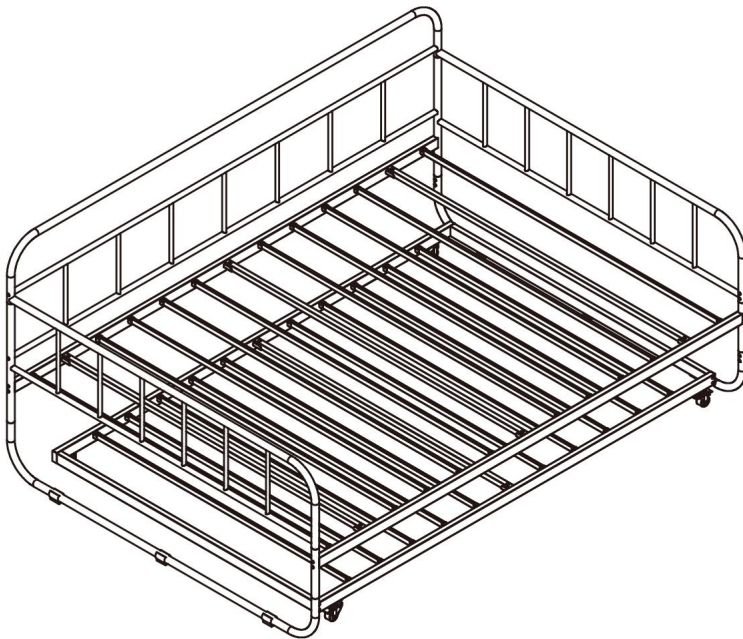

Dit is de originele handleiding. Lees alle instructies zorgvuldig door voordat u het product gebruikt. VEVOR behoudt zich het recht voor om de gebruiksaanwijzing duidelijk te interpreteren. Het uiterlijk van het product is afhankelijk van het product dat u hebt ontvangen. Neemt u het ons niet kwalijk dat we u niet meer op de hoogte stellen van eventuele technologische of software-updates voor ons product.

VEILIGHEIDSINSTRUCTIES

WAARSCHUWING:

Lees dit materiaal voordat u dit product gebruikt. Het niet naleven hiervan kan ernstig letsel tot gevolg hebben.

Vorzorgsmaatregelen bij

montage 1. Monteer uitsluitend volgens deze instructies. Onjuiste montage

kan gevaren opleveren.

2. Draag tijdens de montage een ANSI-goedgekeurde veiligheidsbril en stevige werkhandschoenen.

3. Zorg ervoor dat de verzamelplaats schoon en goed verlicht is.

4. Houd omstanders uit de buurt tijdens de montage.

5. Niet inpakken als u moe bent of onder invloed van alcohol of drugs.

of medicijnen.

6. De producteigenschappen gelden uitsluitend voor producten die volledig en naar behoren zijn gemonteerd.

7. Monteer de hemelbedden op een vlak, egaal, hard en glad oppervlak dat de hemelbedden veilig kan dragen.

8. Indien mogelijk kunt u elektrisch gereedschap gebruiken om de montage te vergemakkelijken.

9. Voor aanvullende informatie over de onderdelen die in de volgende lijst staan vermeld,

Raadpleeg voor meer informatie het montageschema in deze handleiding. Pak alle onderdelen uit en scheid ze van elkaar op een schone werkplek.

Neem

voorzorgsmaatregelen 1. Overschrijd de aangegeven gewichtscapaciteit niet.

2. Gebruik het alleen op een vlak, egaal, hard en glad oppervlak dat veilig kan worden gebruikt.











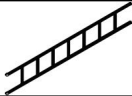











ondersteunen een volledig uitgeruste hemelbed.

3. Gebruik het product alleen zoals bedoeld.

4. Controleer het product voor elk gebruik. Niet gebruiken als er onderdelen loszitten of beschadigd zijn.

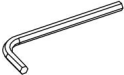
BEWAAR DEZE HANDLEIDING

ONDERDELENLIJST

Item Nee.	Referentie Afbeelding	Aantal	Artikelnr.	Referentie Afbeelding	Aantal
1		X1	8		X2
2		X1	9		X2
3		X1	10		X2
4		X1	11		X3
5		X2	12		X1
6		X2	13		X10
7		X2	14		X10
A	 M8*15	X12	F		X2
B	 M8*30	X8	G		X2
C	 M8*40	X8	H	 M5	X1
D	 M8*50	X16	O		X1
E		X16			

EXPLODED VIEW

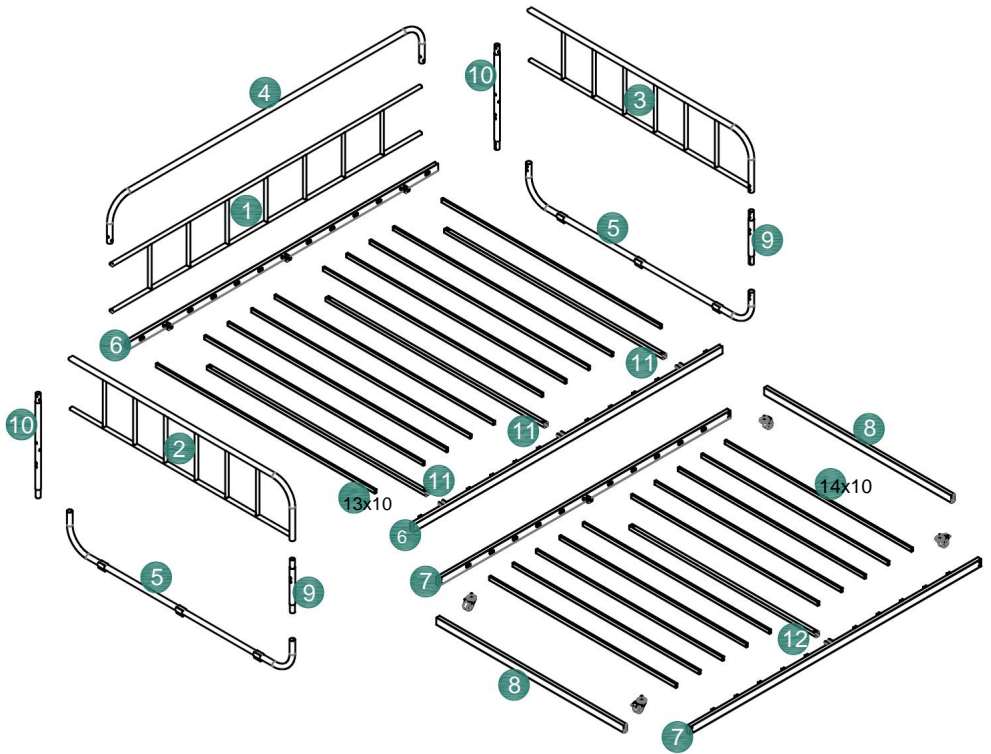

MONTAGESTAP

1



5 x2



9x2



10x2

M8*15



Fer x8

M5



H

Let op: Om het u gemakkelijker te maken

installatie, draai de schroeven vast tot 70%
tijdens de installatie.

Stap 1

Stap 2

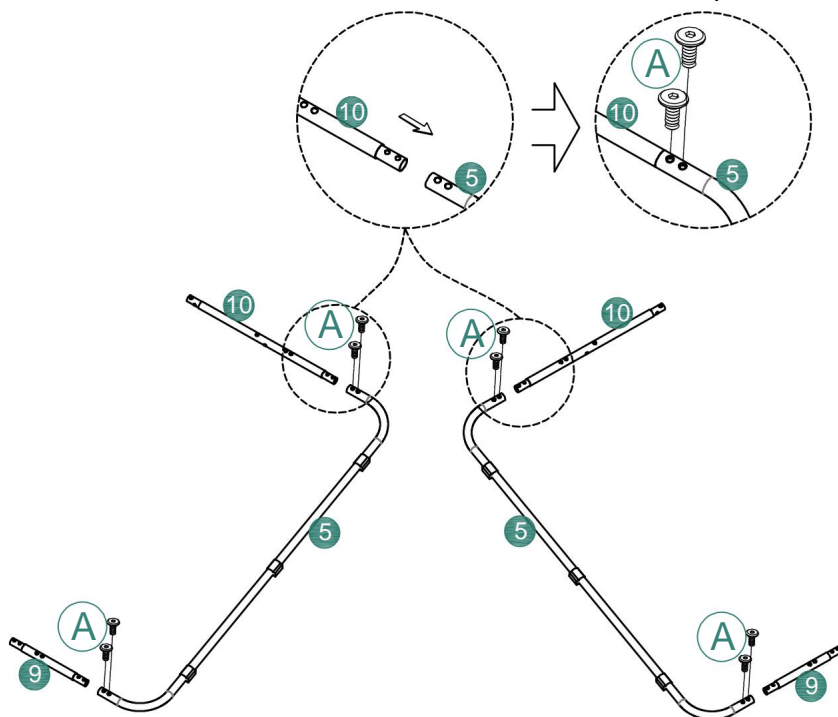

2



6x2

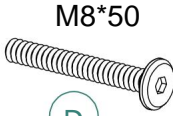

D x8



E x8

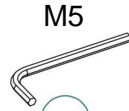

M5

H

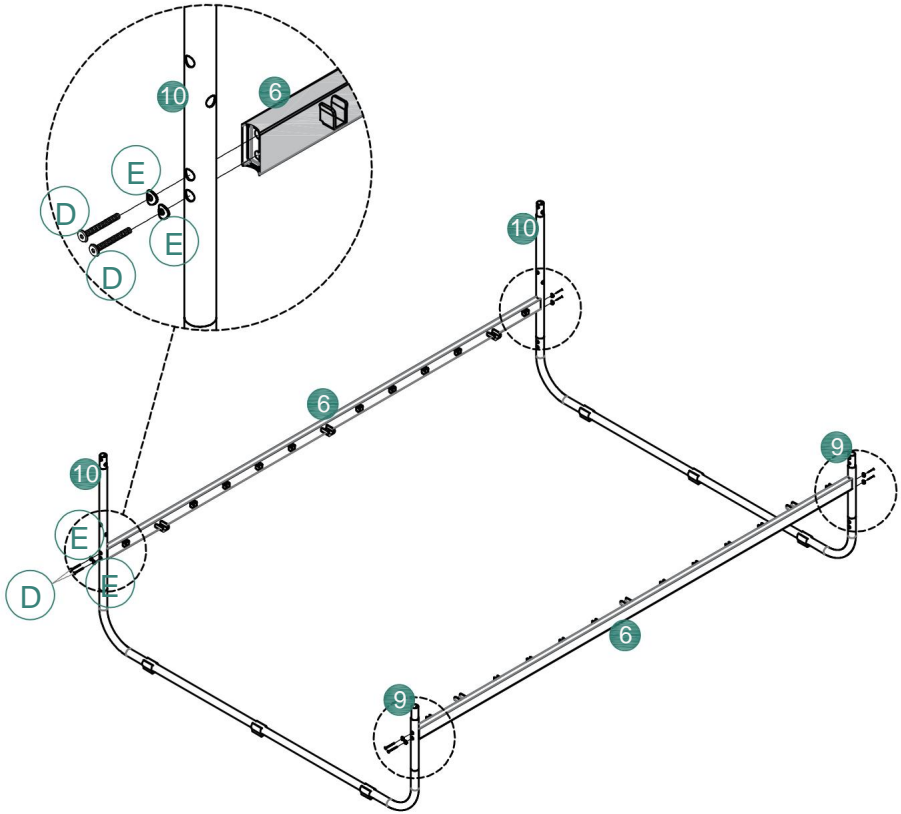

3



1 x1



4 x1



D x4



E x4

M5



H

Step 1

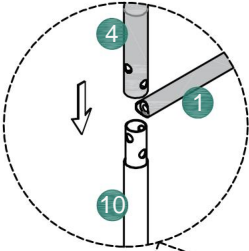

Step 2

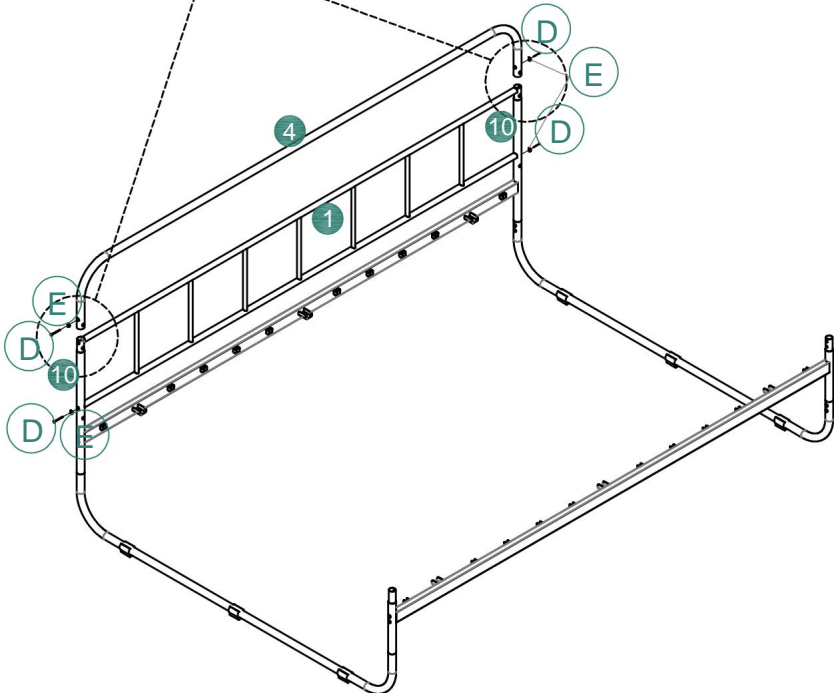
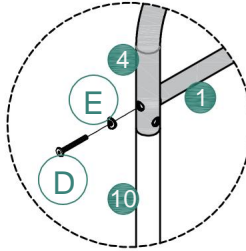

4



2x1



3x1

M8*15



Ee x4

M8*50



D x4



E x4

M5



H

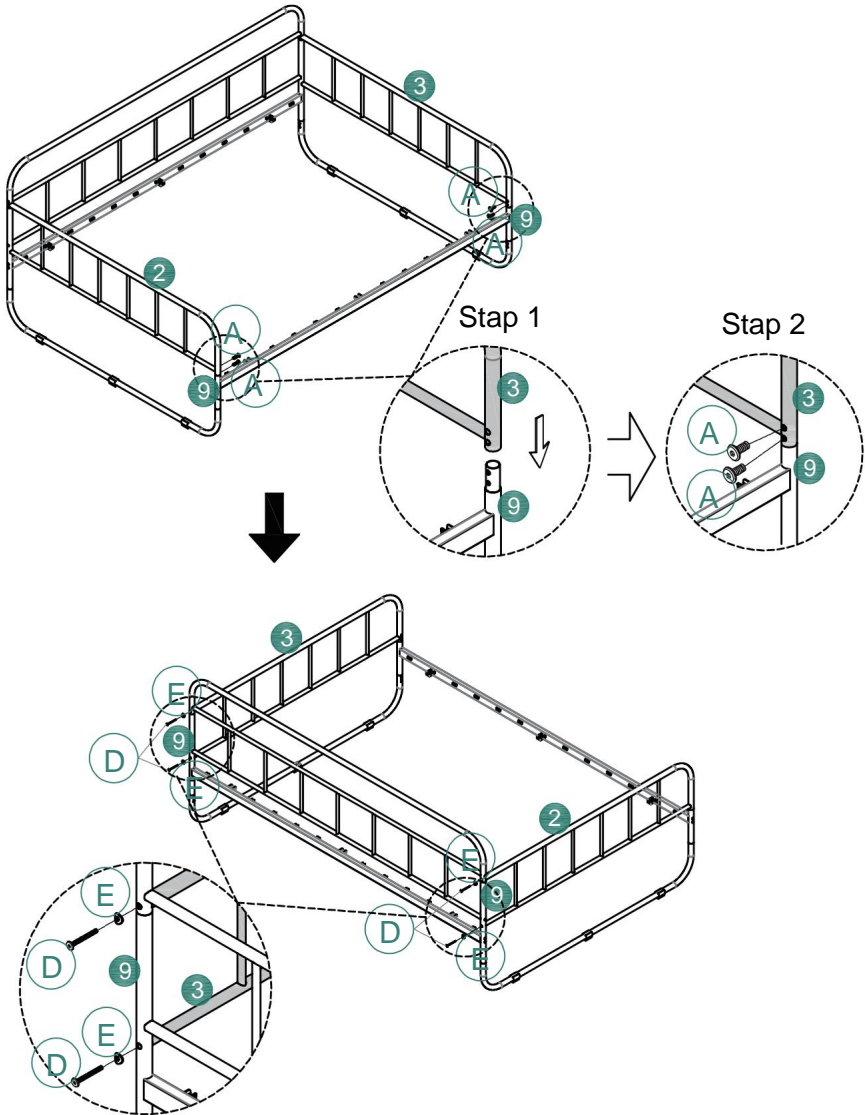

5



11x3

M8*30



B x6

M5



H

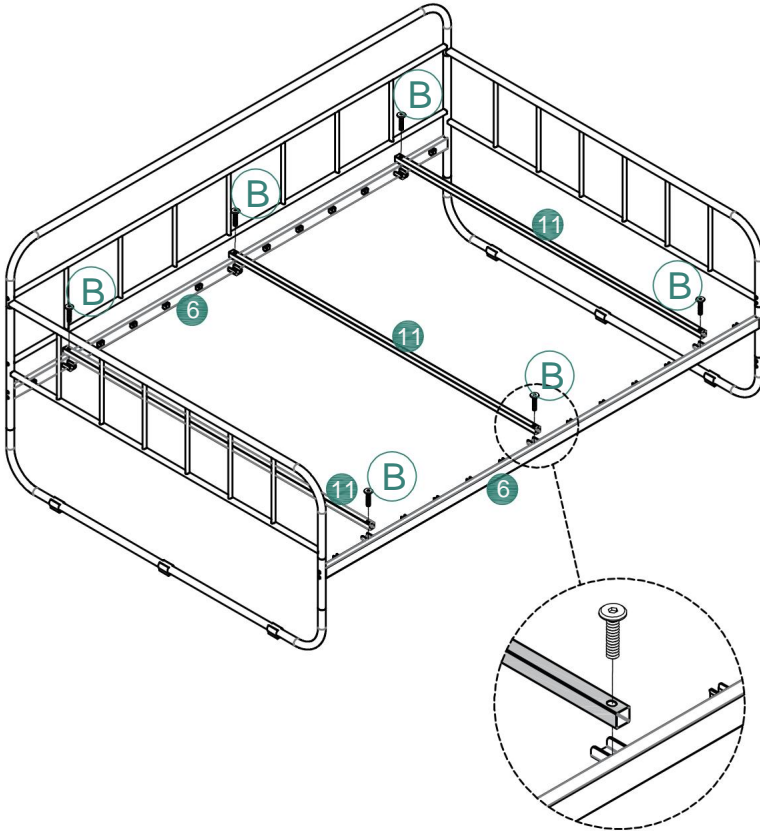

6

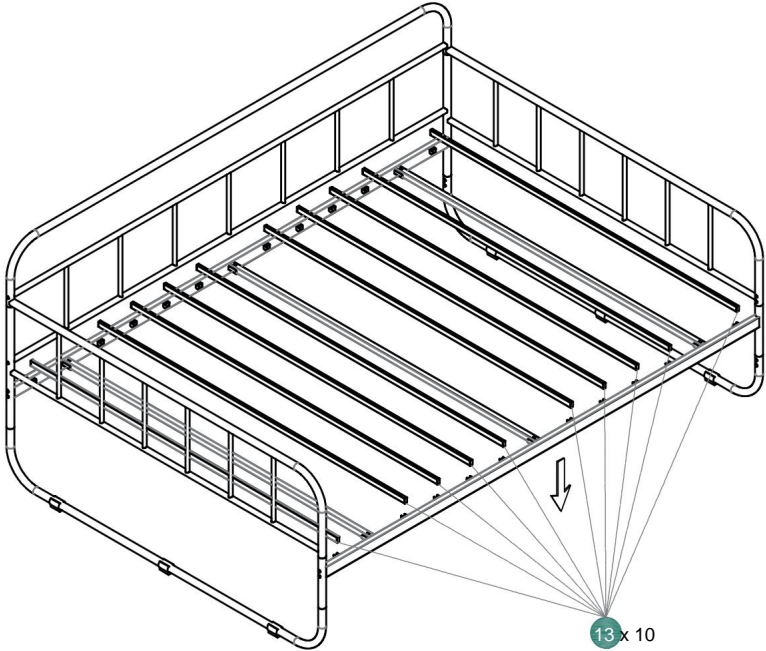
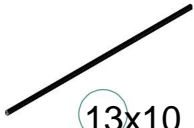

7



7x2



8x2



Cx8

M5



H

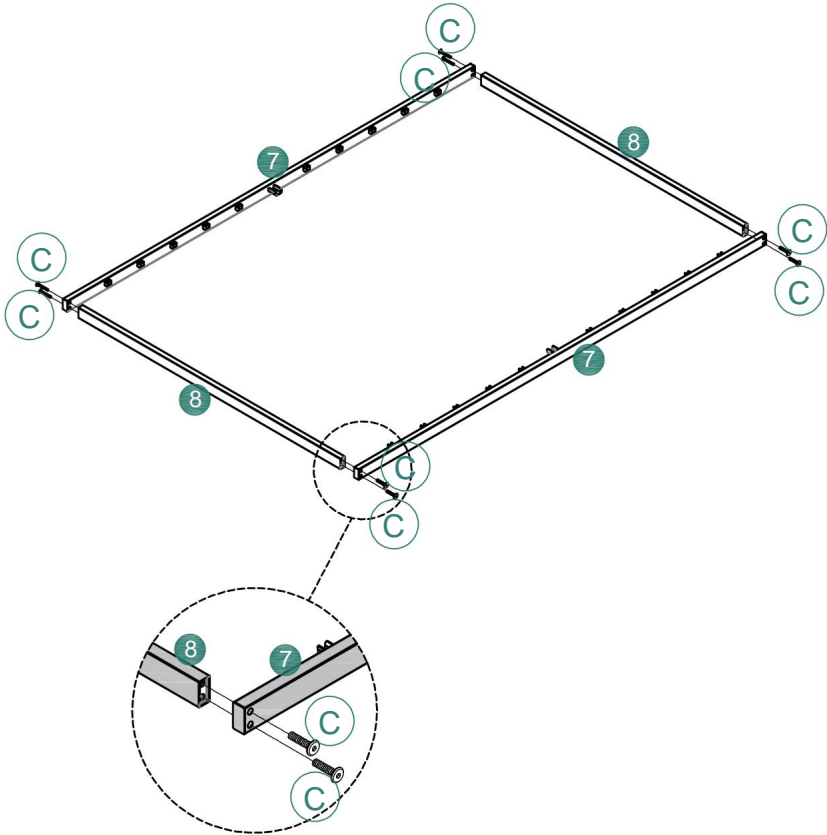

8



12x1



14x10



B_{x2}



H

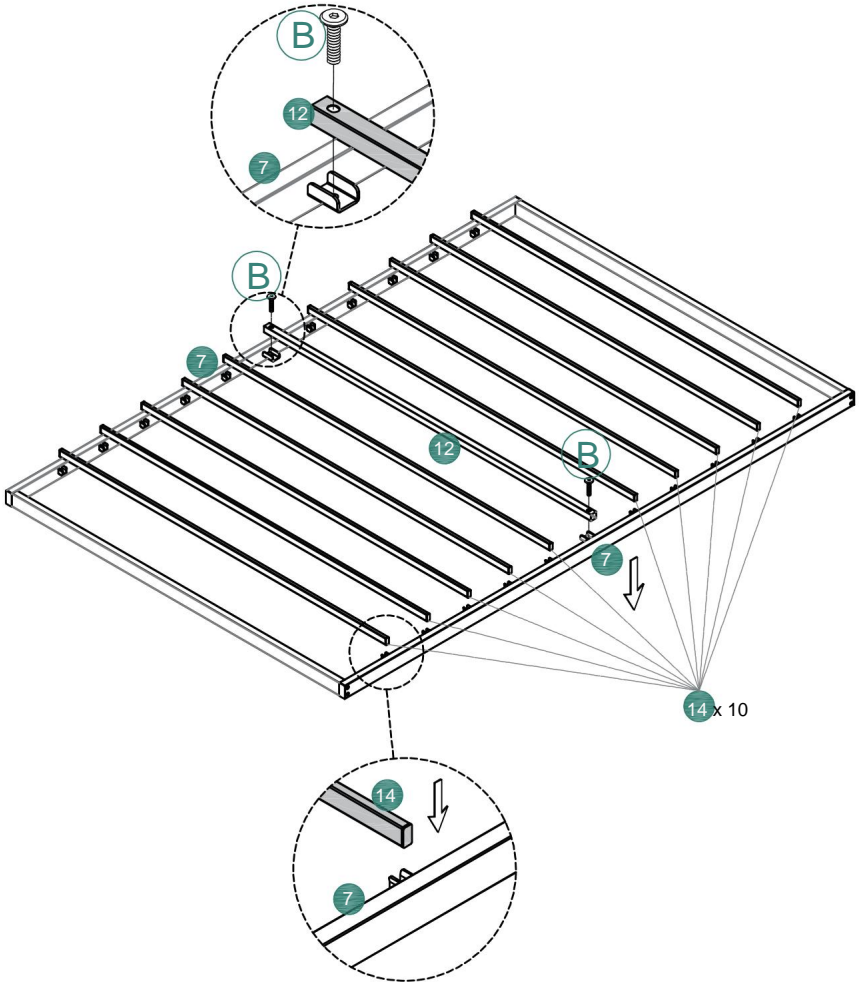

9



F x2



G x2 O O

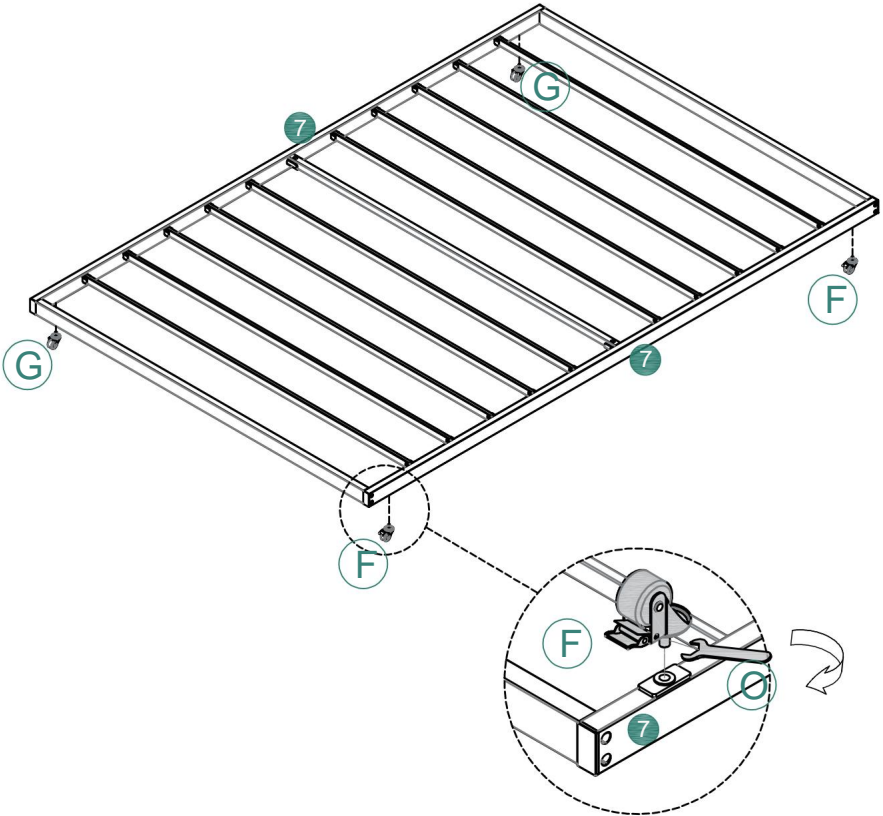

10

Montagemetode A

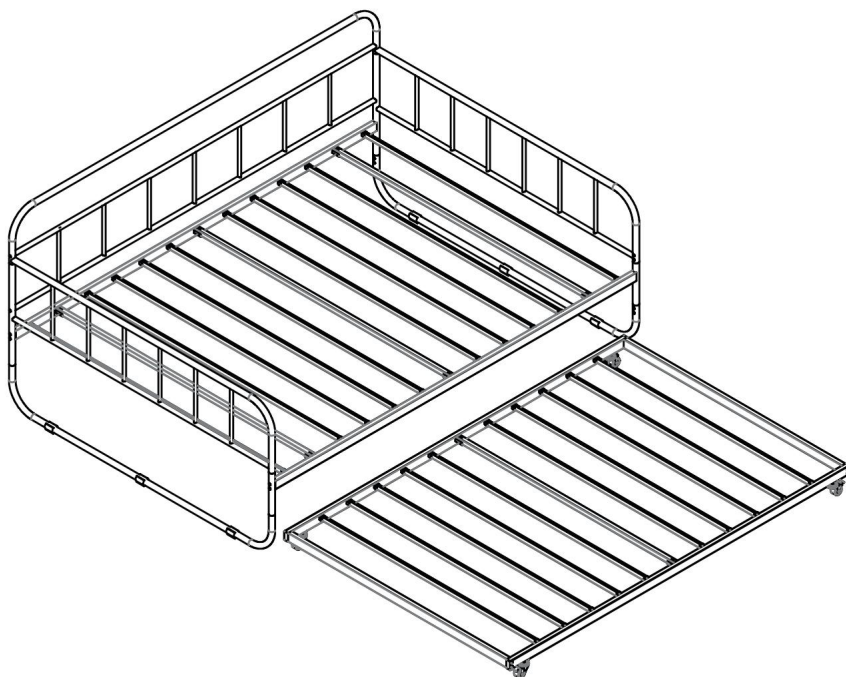

11

Controleer en draai alle schroeven vast

Montagemethode B

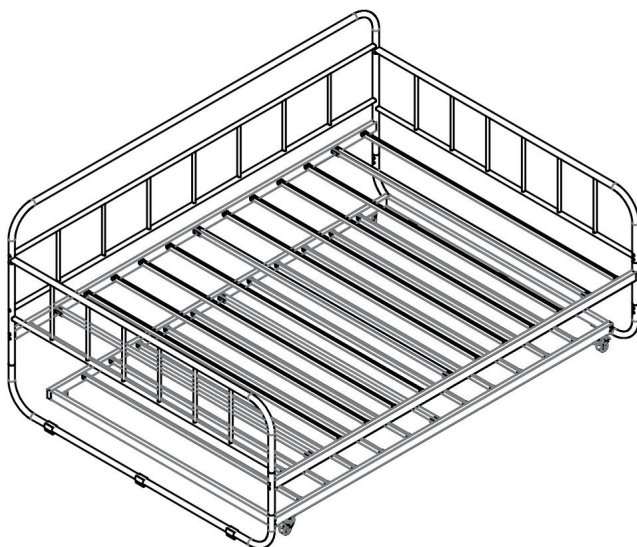

Fabrikant: Shanghaimuxinmuyeyouxiangongsi Adres:

Shuangchenglu 803nong11hao1602A-1609shi, baoshanqu, shanghai 200000 CN.

Geïmporteerd naar AUS: SIHAO PTY LTD. 1 ROKEVASTREETEASTWOOD

NSW 2122 Australië

Geïmporteerd naar de VS: Sanven Technology Ltd. Suite 250, 9166 Anaheim Place,

Rancho Cucamonga, CA 91730



E-CrossStu GmbH

Mainzer Landstr.69, 60329 Frankfurt am Main.



YH CONSULTING LIMITED.

C/O YH Consulting Limited Kantoor 147, Centurion House,

London Road, Staines-upon-Thames, Surrey,

TW18 4AX



VEVOR

Affordable. Reliable. Home Improvement.

DAGBÄDDAR

MODELL: YJX-BF-001

VEVOR

Affordable. Reliable. Home Improvement.

DAGBÄDDAR

MODELL: YJX-BF-001

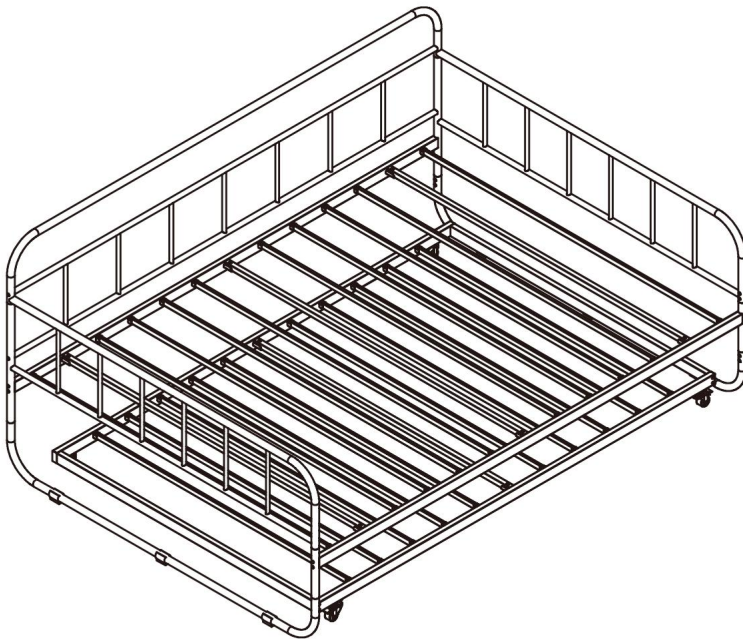

Detta är originalinstruktionerna, vänligen läs alla instruktioner noggrant innan du använder produkten. VEVOR förbehåller sig en tydlig tolkning av vår användarmanual. Produktens utseende ska vara beroende av den produkt du mottagit. Vi ber om ursäkt för att vi inte kommer att informera dig igen om det finns några teknik- eller programuppdateringar för vår produkt.

SÄKERHETSINSTRUKTIONER

VARNING: Läs

detta material innan du använder produkten. Underlåtenhet att göra det kan leda till allvarliga skador.

Monteringsföreskrifter 1.

Montera endast enligt dessa instruktioner. Felaktig montering kan skapa faror.

2. Använd ANSI-godkända skyddsglasögon och kraftiga arbetshandskar under monteringen.
3. Håll samlingsområdet rent och väl upplyst.
4. Håll åskådare borta från området under monteringen.
5. Montera inte om du är trött eller påverkad av alkohol eller droger eller medicinering.
6. Produktens egenskaper gäller endast korrekt och fullständigt monterade produkter.
7. Montera på en plan, jämn, hård och slät yta som säkert kan bära upp baldakinerna.
8. Om möjligt kan du använda elverktyg för att underlätta monteringen.
9. För ytterligare information om de delar som listas i följande sidorna, se monterings schemat i denna manual. Packa upp och separera alla delar på en ren arbetsyta.











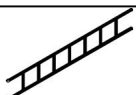











Använd

försiktighetsåtgärder 1. Överskrid inte angivna viktkapaciteter.

2. Använd endast på en plan, jämn, hård och slät yta som säkert kan stödja en fullt lastad baldakinsäng.
3. Använd endast enligt avsikten.
4. Kontrollera före varje användning; använd inte om delar är lösa eller skadade.

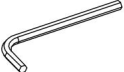
SPARA DENNA HANDBOK

DELLISTA

Punkt Inga.	Hänvisning Bild	Antal	Artikelnummer	Hänvisning Bild	Antal
①		X1	⑧		X2
②		X1	⑨		X2
③		X1	⑩		X2
④		X1	⑪		X3
⑤		X2	⑫		X1
⑥		X2	⑬		X10
⑦		X2	⑭ ○		X10
En	 M8*15	X12	F		X2
B	 M8*30	X8	G		X2
C	 M8*40	X8	H	 M5	X1
D	 M8*50	X16	O		X1
E		X16			

SPRÄNGSKISS

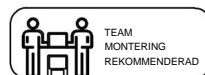
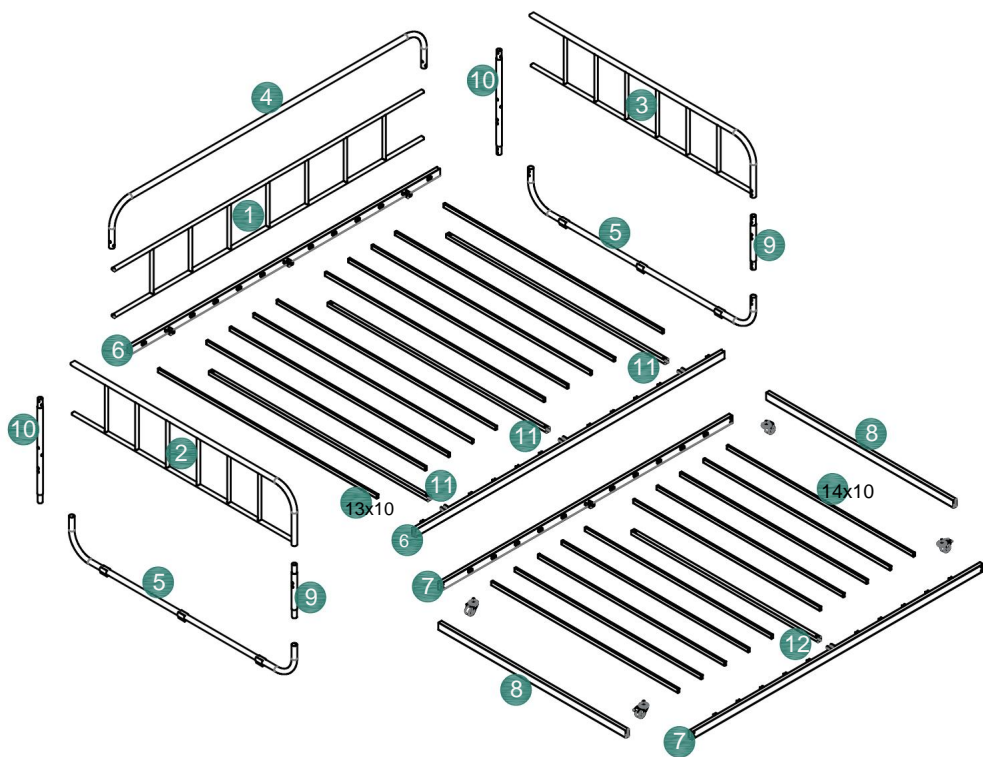

MONTERINGSSTEG

1



5 x2



9x2



10x2

M8*15



En x8

M5



H

Obs: För att underlätta installation, var vänlig och lås skruvarna till 70 % under installationen.

Steg 1

Steg 2

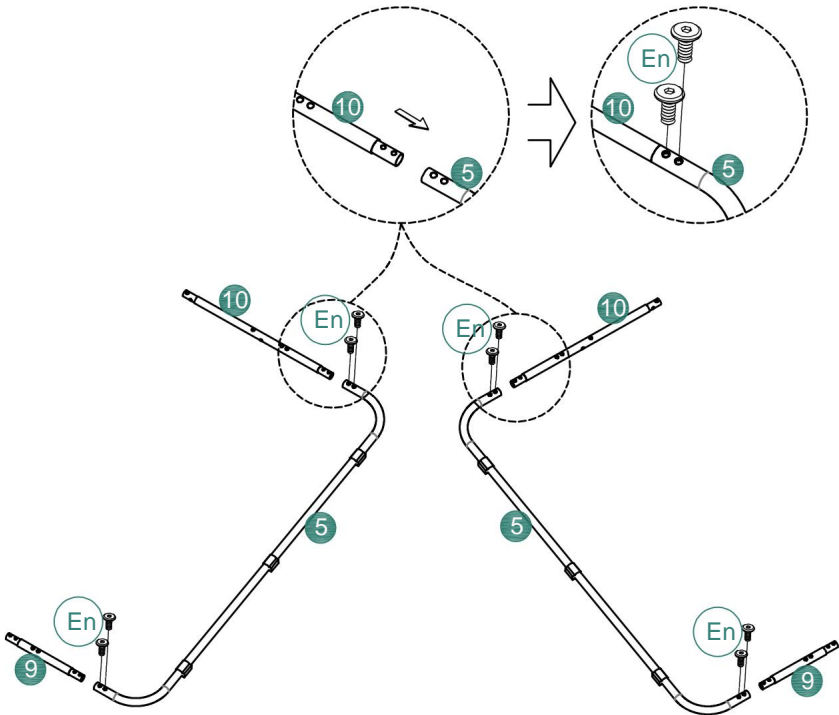

2



6x2

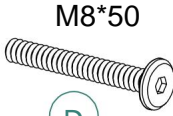

D x8



E x8

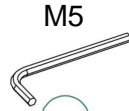

M5

H

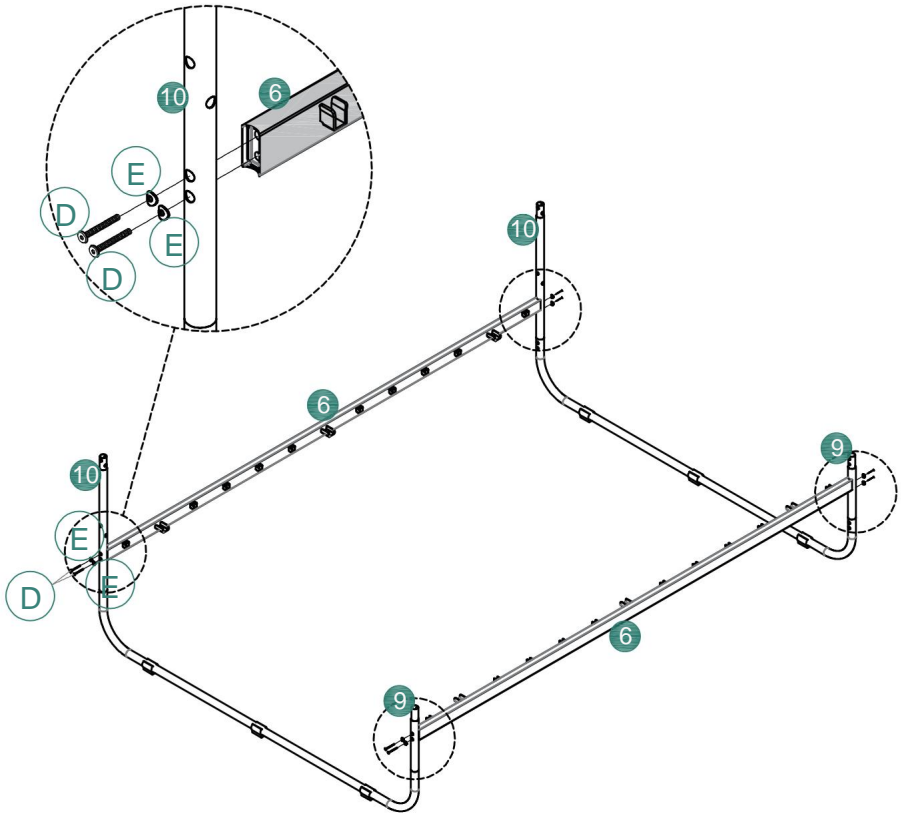

3



1 x1



4x1



D x4



E x4

M5



H

Step 1

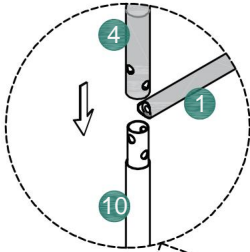

Step 2

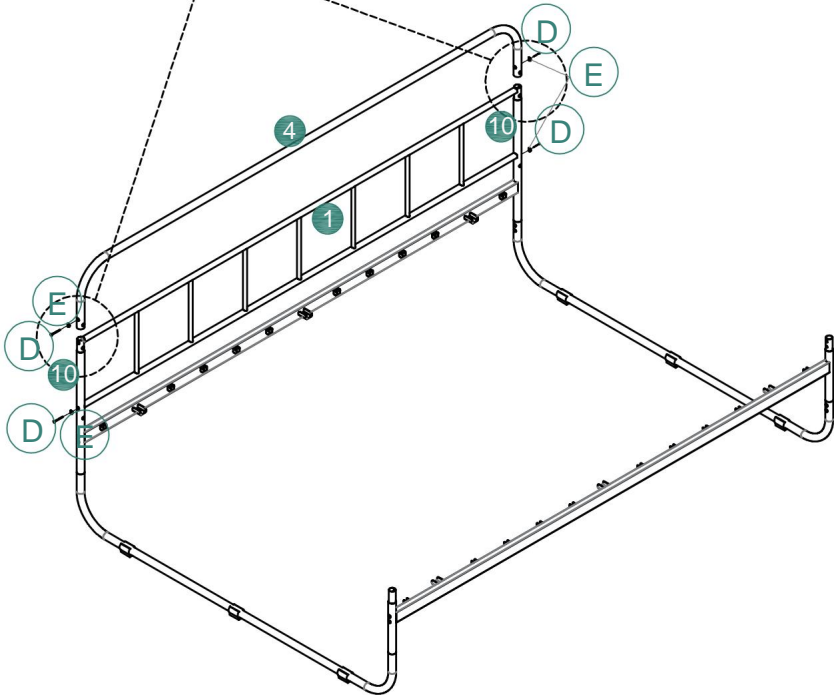
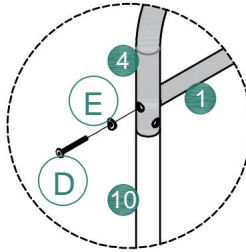

4

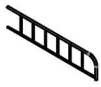

2x1

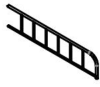

3x1

M8*15



Enx4

M8*50



Dx4



Ex4

M5



H

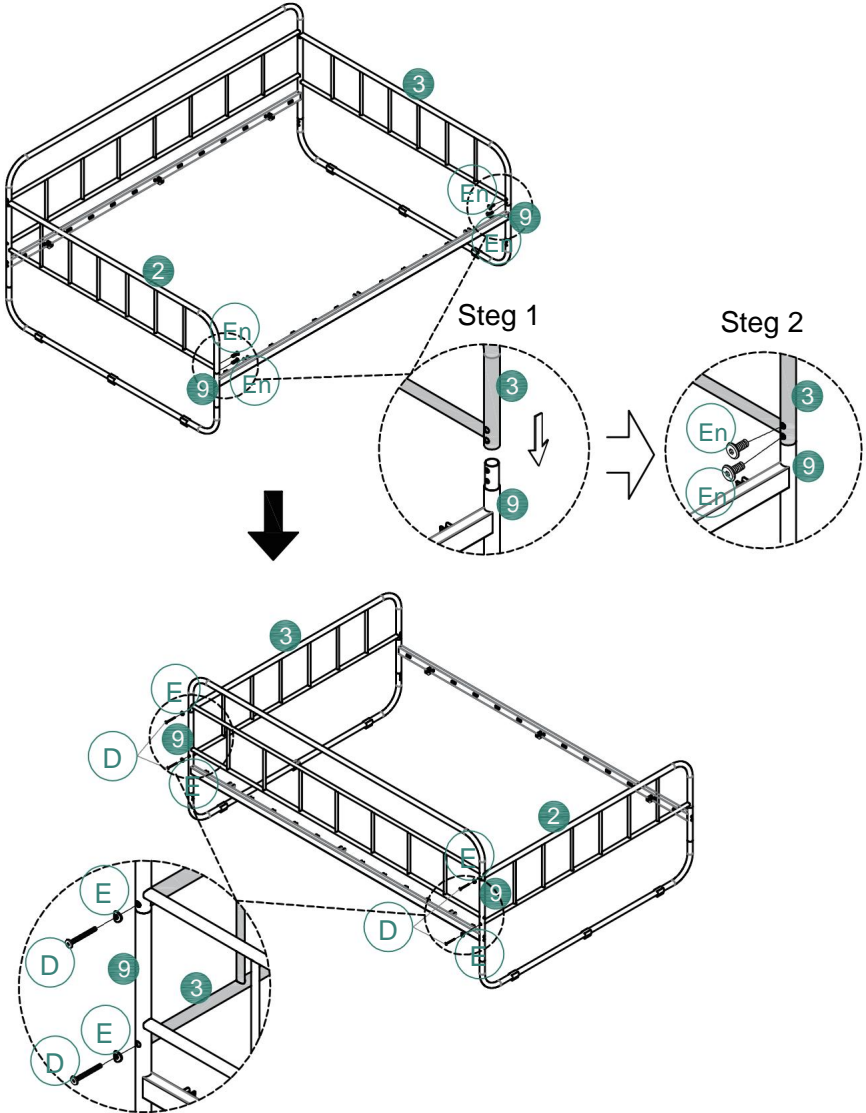

5



11x3

M8*30



B x6

M5



H

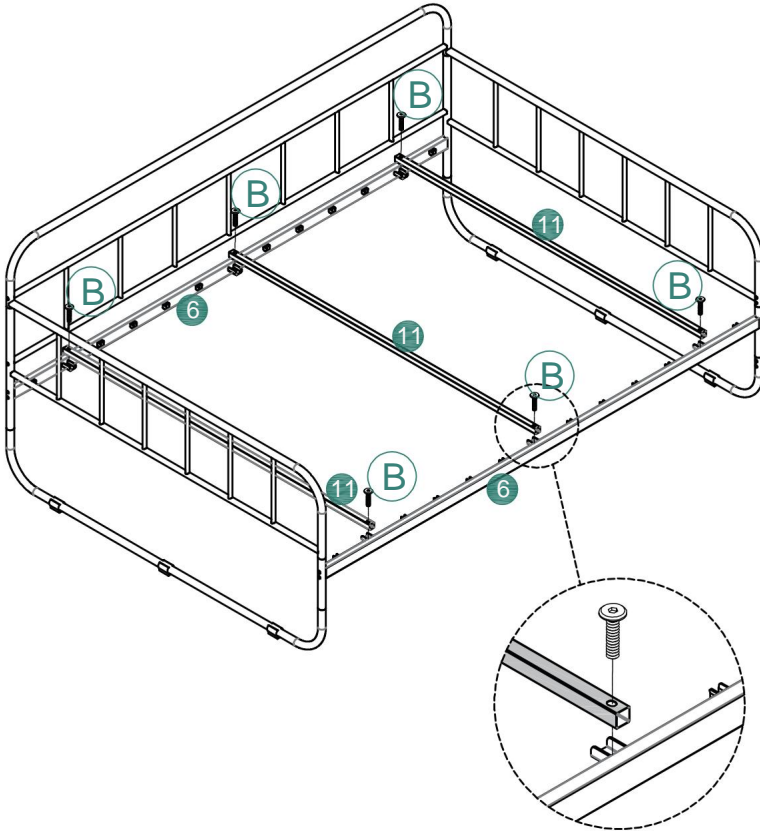

6

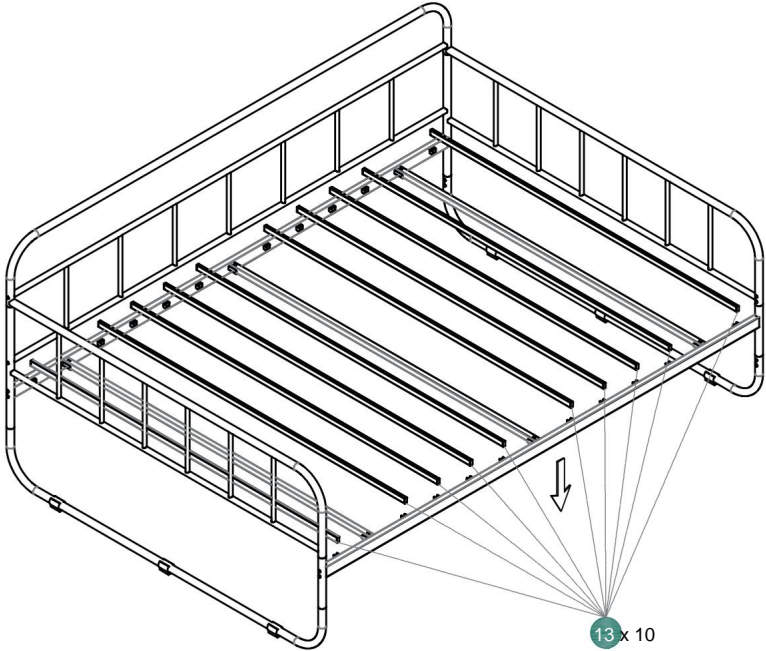
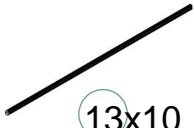

7



7x2



8x2



C x8

M5



H

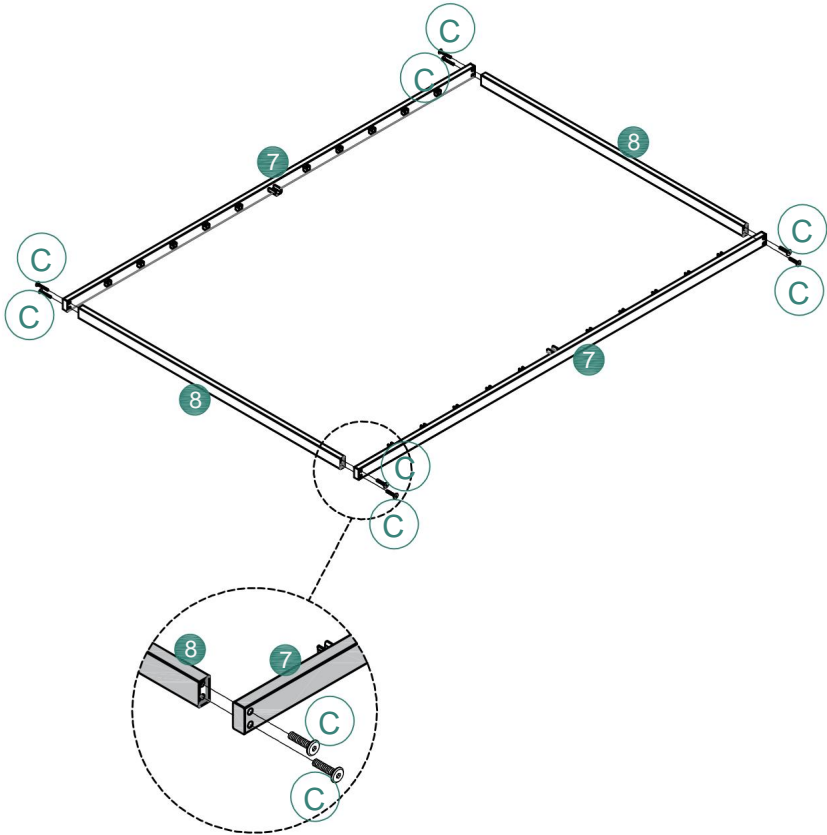

8



12x1



14x10



B x2



H

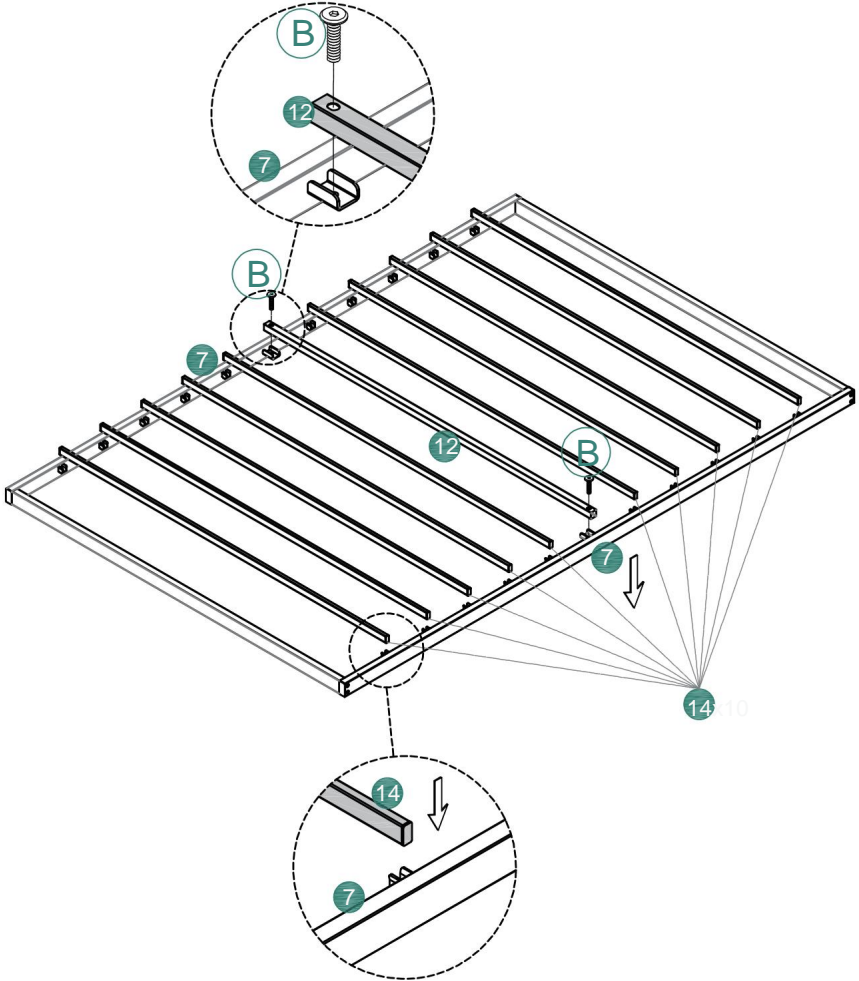

9



F x2



G x2 O O

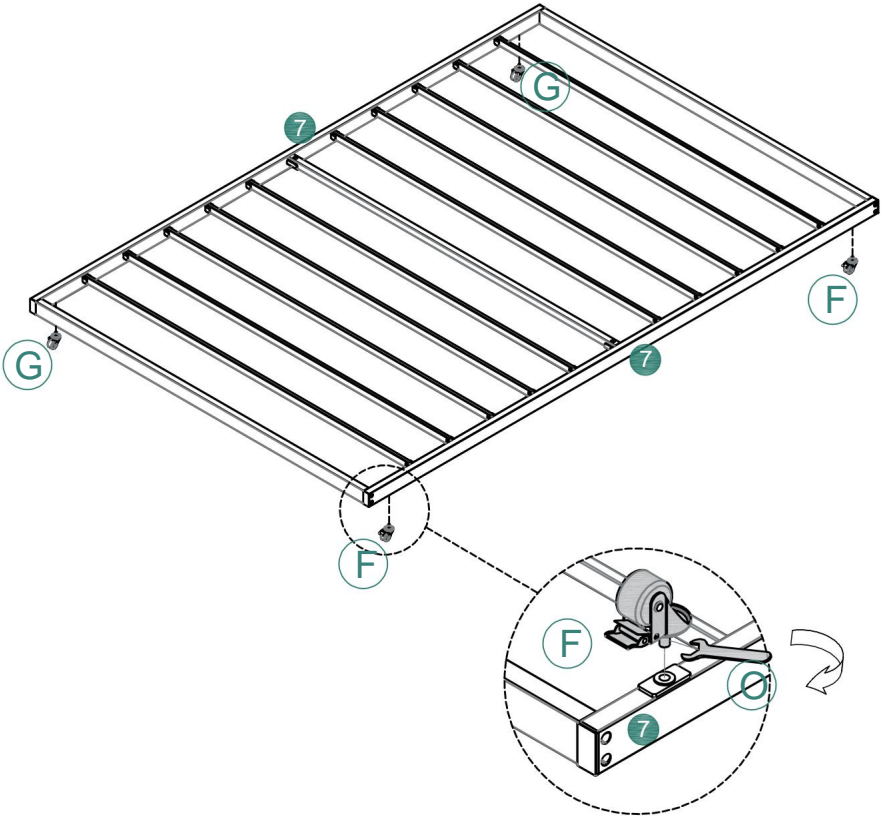

10

Monteringsmetod A

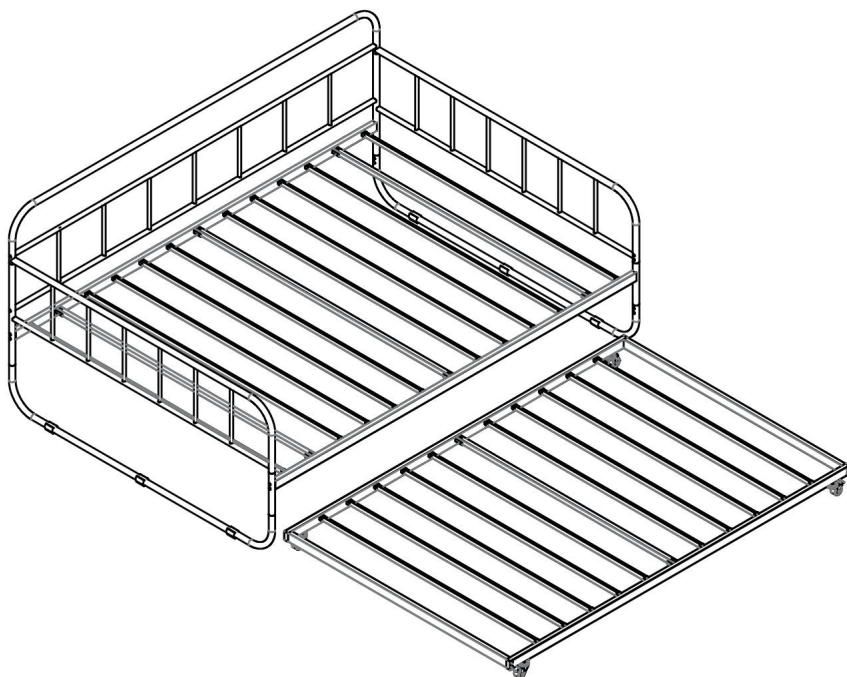

11

Kontrollera och dra åt alla skruvar

Monteringsmetod B

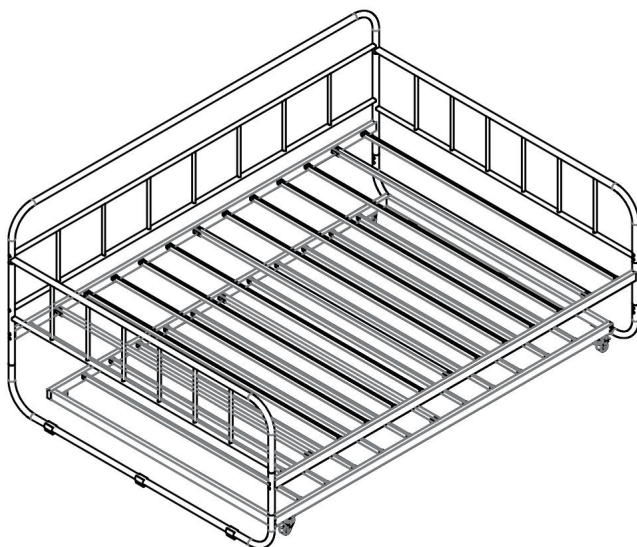

Tillverkare: Shanghaimuxinmuyeyouxiangongsi Adress:

Shuangchenglu 803nong11hao1602A-1609shi, baoshanqu, shanghai 200000 CN.

Importerad till Australien: SIHAO PTY LTD. 1 ROKEVASTREETEASTWOOD

NSW 2122 Australien

Importerad till USA: Sanven Technology Ltd. Suite 250, 9166 Anaheim Place, Rancho

Cucamonga, CA 91730



E-CrossStu GmbH

Mainzer Landstr.69, 60329 Frankfurt am Main.



YH CONSULTING LIMITED.

C/O YH Consulting Limited Kontor 147, Centurion House,

London Road, Staines-upon-Thames, Surrey

TW18 4AX



VEVOR

Affordable. Reliable. Home Improvement.

CAMAS DE DÍA

MODELO: YJX-BF-001

VEVOR

Affordable. Reliable. Home Improvement.

CAMAS DE DÍA

MODELO: YJX-BF-001

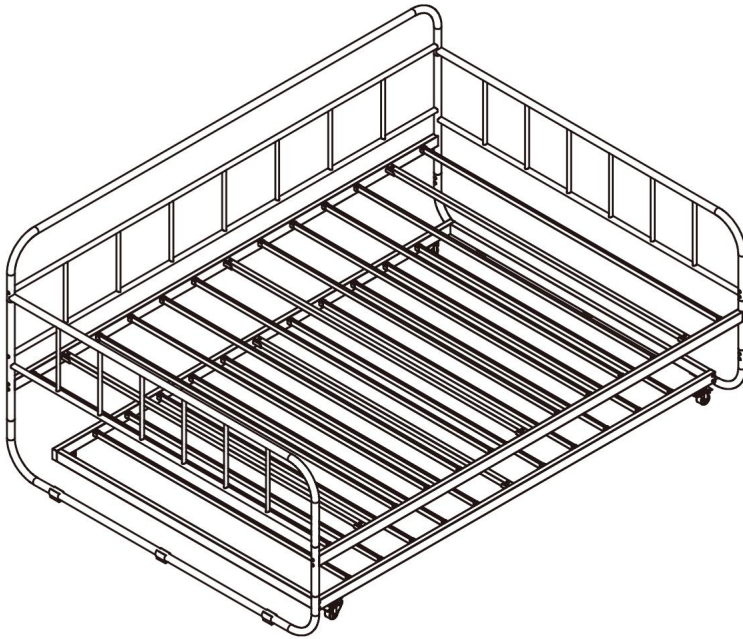

Estas son las instrucciones originales; lea atentamente todas las instrucciones del manual antes de utilizarlo. VEVOR se reserva el derecho de interpretar este manual de usuario. La apariencia del producto dependerá del producto que haya recibido. Le rogamos que nos disculpe si no le informamos de nuevo si hay actualizaciones tecnológicas o de software en nuestro producto.

INSTRUCCIONES DE SEGURIDAD

ADVERTENCIA:

Lea este material antes de usar este producto. De lo contrario, podría sufrir lesiones graves.

Precauciones de montaje 1.

Ensamble únicamente de acuerdo con estas instrucciones. Montaje incorrecto

Puede crear peligros.











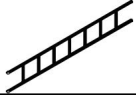









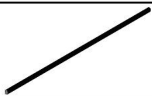

2. Use gafas de seguridad aprobadas por ANSI y guantes de trabajo resistentes durante el montaje.
3. Mantenga el área de reunión limpia y bien iluminada.
4. Mantenga a los transeúntes fuera del área durante el montaje.
5. No se reúna si está cansado o bajo la influencia del alcohol o drogas.
o medicación.
6. Las capacidades del producto se aplican únicamente a productos ensamblados correcta y completamente.
7. Ensamble sobre una superficie plana, nivelada, dura y lisa capaz de soportar de manera segura las camas con dosel.
8. Si es posible, puedes utilizar herramientas eléctricas para facilitar el montaje.
9. Para obtener información adicional sobre las piezas enumeradas a continuación,
Para obtener más información sobre las páginas, consulte el diagrama de montaje de este manual.
Desembale y separe todas las piezas en un área de trabajo limpia.

Precauciones de uso

1. No exceda las capacidades de peso especificadas.
2. Úselo solo sobre una superficie plana, nivelada, dura y lisa que pueda
Admite camas con dosel completamente cargadas.
3. Úselo únicamente según lo previsto.
4. Inspeccione antes de cada uso; no lo utilice si las piezas están sueltas o dañadas.

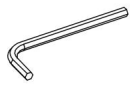
GUARDE ESTE MANUAL

LISTA DE PIEZAS

Artículo No.	Referencia Imagen	Cantidad	Artículo No.	Referencia Imagen	Cantidad
1		X1	8		X2
2		X1	9		X2
3		X1	10		X2
4		X1	11		X3
5		X2	12		X1
6		X2	13		X10
7		X2	14		X10
A	 M8*15	X12	F		X2
B	 M8*30	X8	GRAMO		X2
do	 M8*40	X8	H	 M5	X1
D	 M8*50	X16	Oh		X1
mi		X16			

VISTA DESPIECE

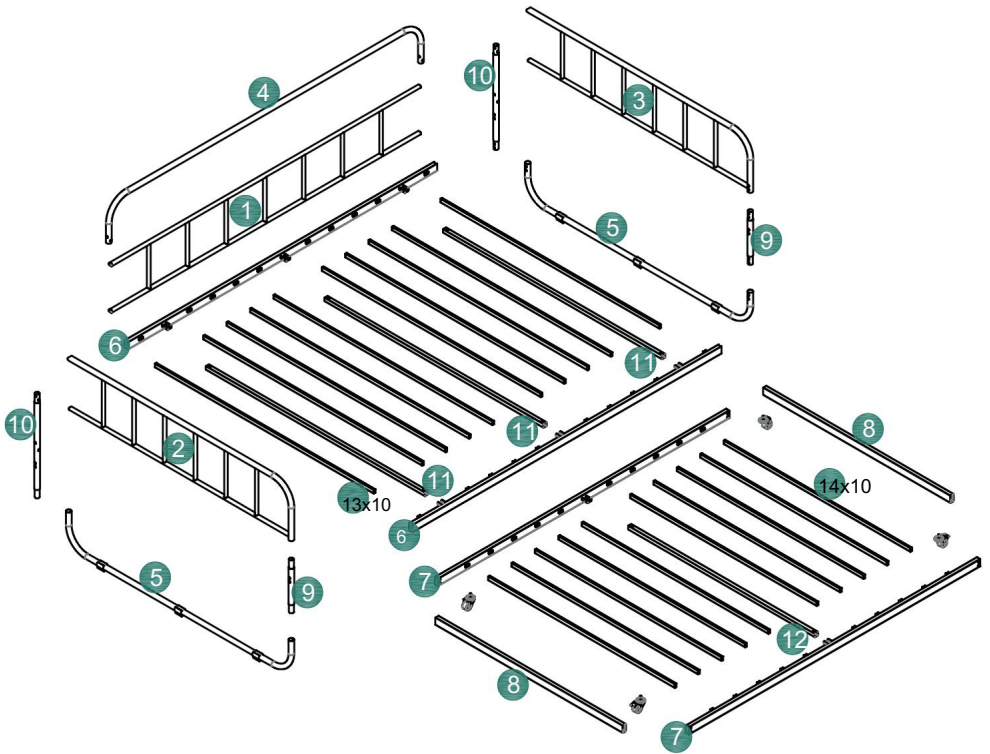

PASO DE MONTAJE

1



5 x2



9 x2



10x2



M8*15
Un x8

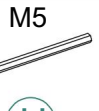

M5
H

Nota: Para facilitar
Instalación, bloquee los tornillos al 70%.
Durante la instalación.

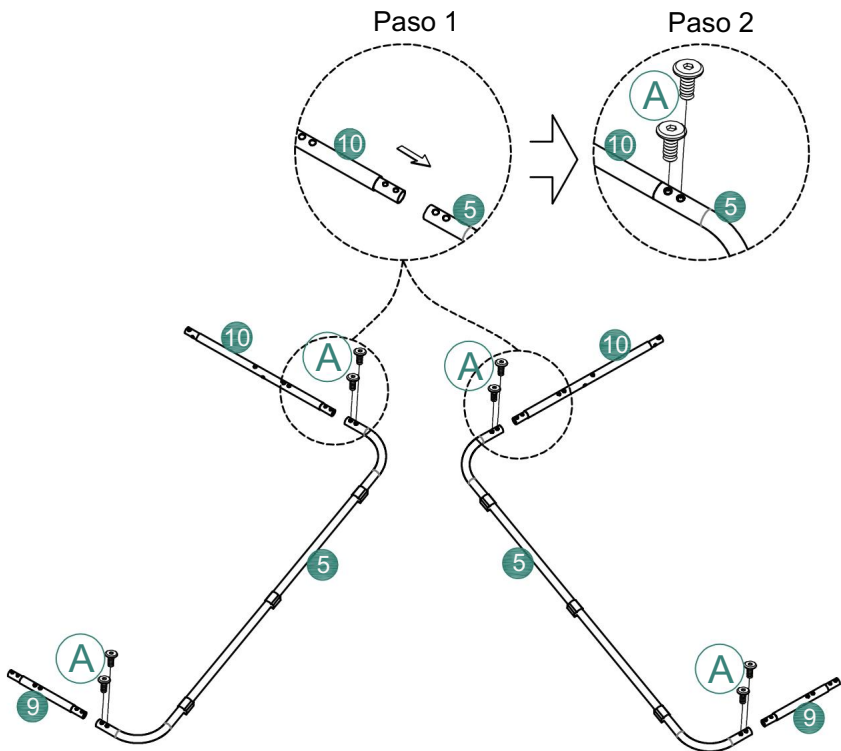

2



6 x 2

M8*50



D x 8



E x 8

M5



H

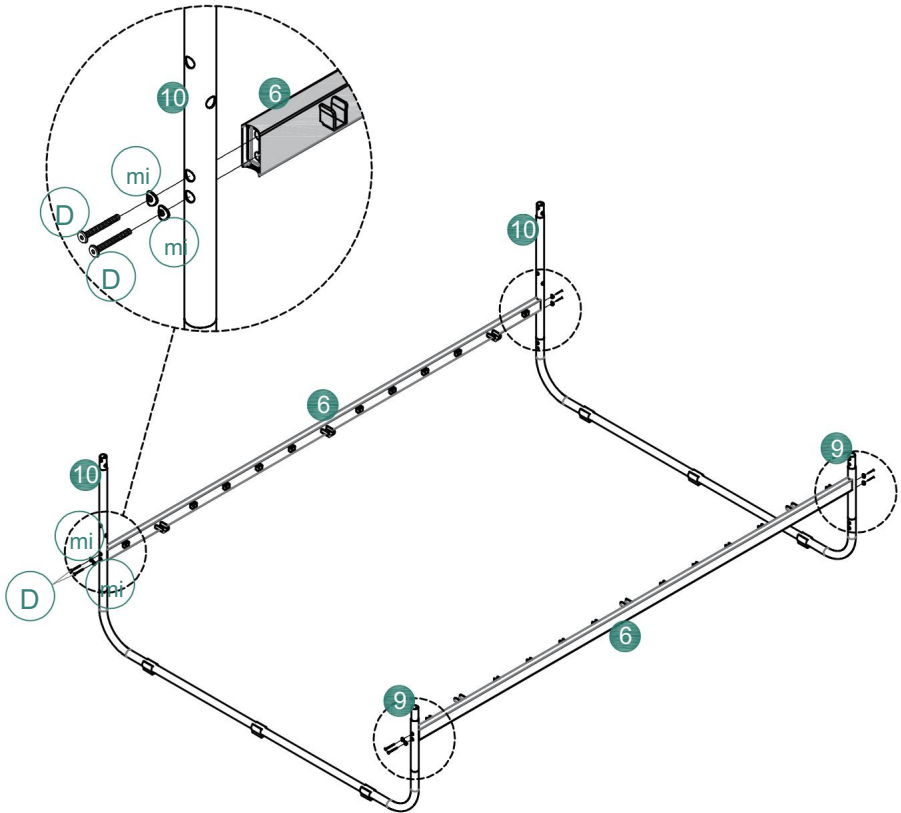

3



1 x1



4x1

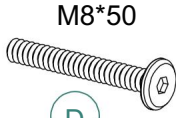

M8*50

D x4



E x4

M5



H

Paso 1

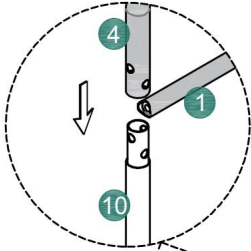

Paso 2

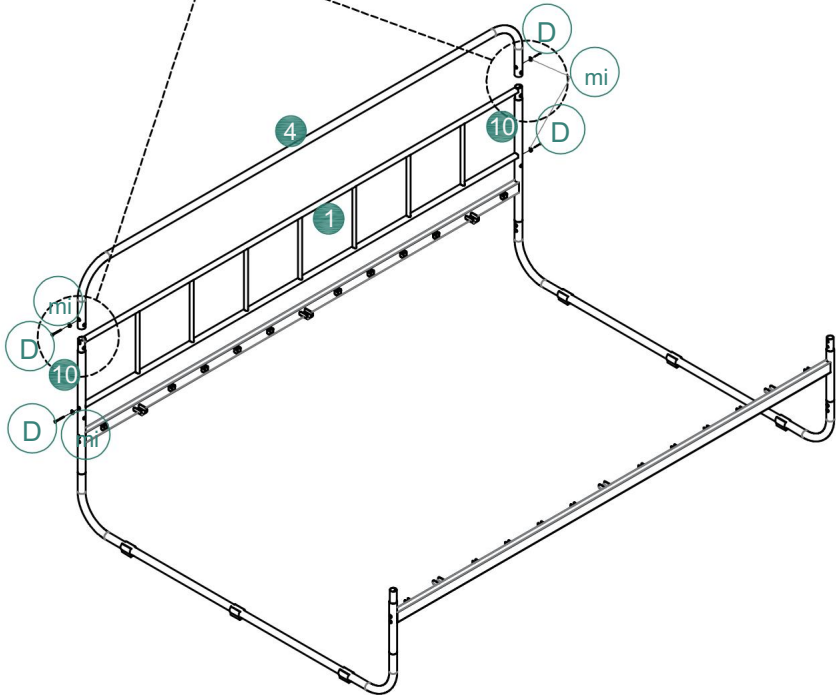
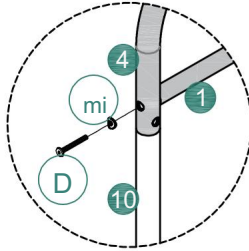

4



2x1



3x1

M8*15



Ux4

M8*50



Dx4



E x4

M5



H

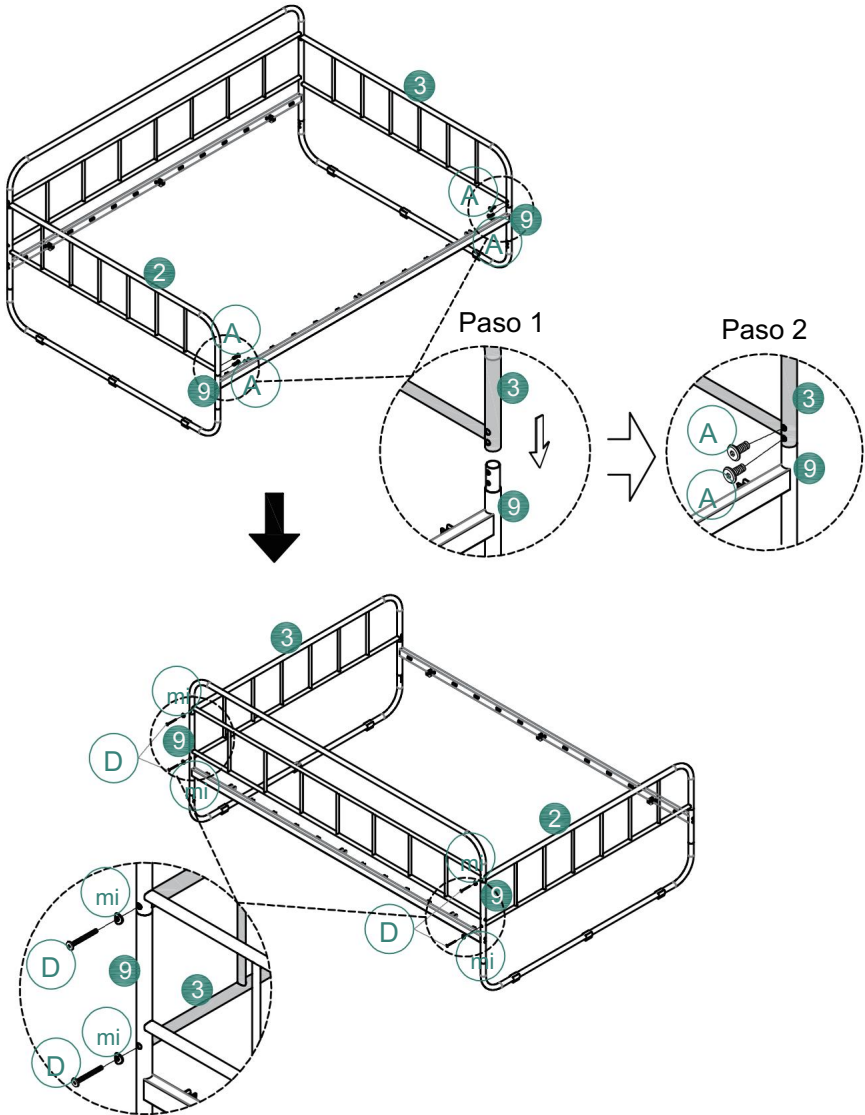

5



11x3

M8*30



B x6

M5



H

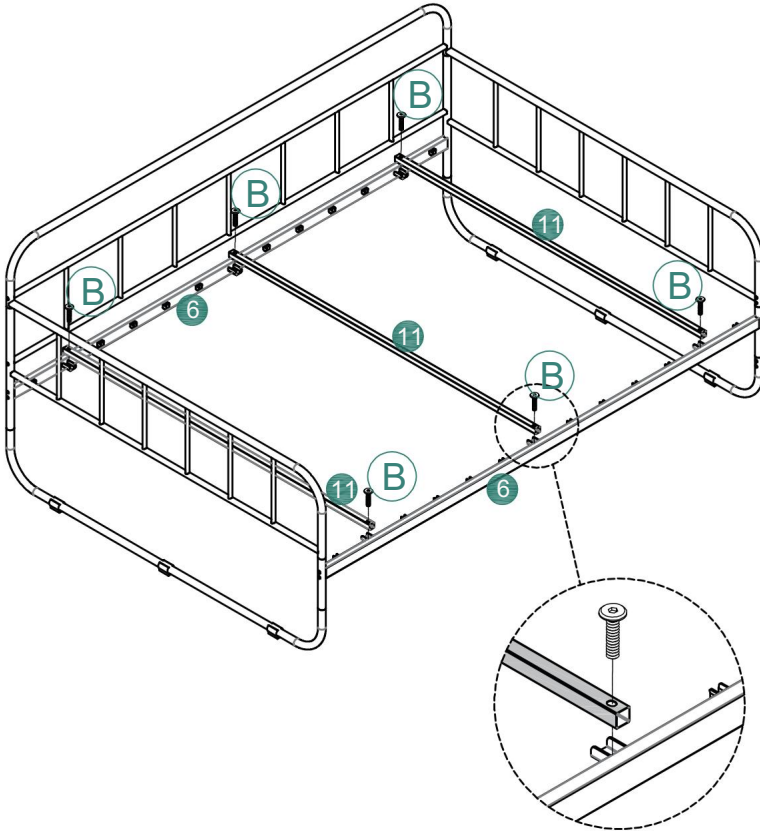

6

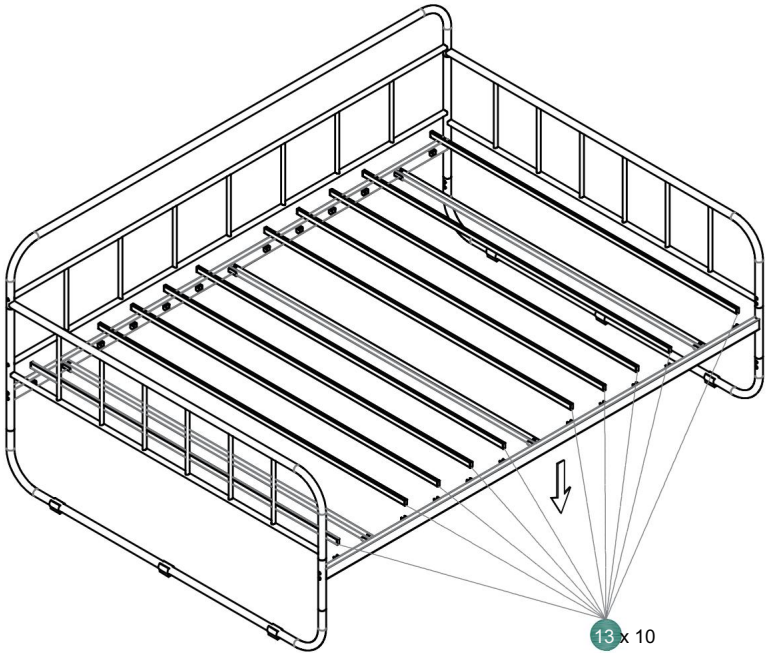
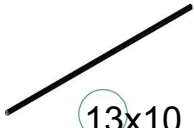

7



7
x2



8
x2



C
x8

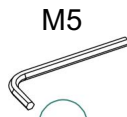

H

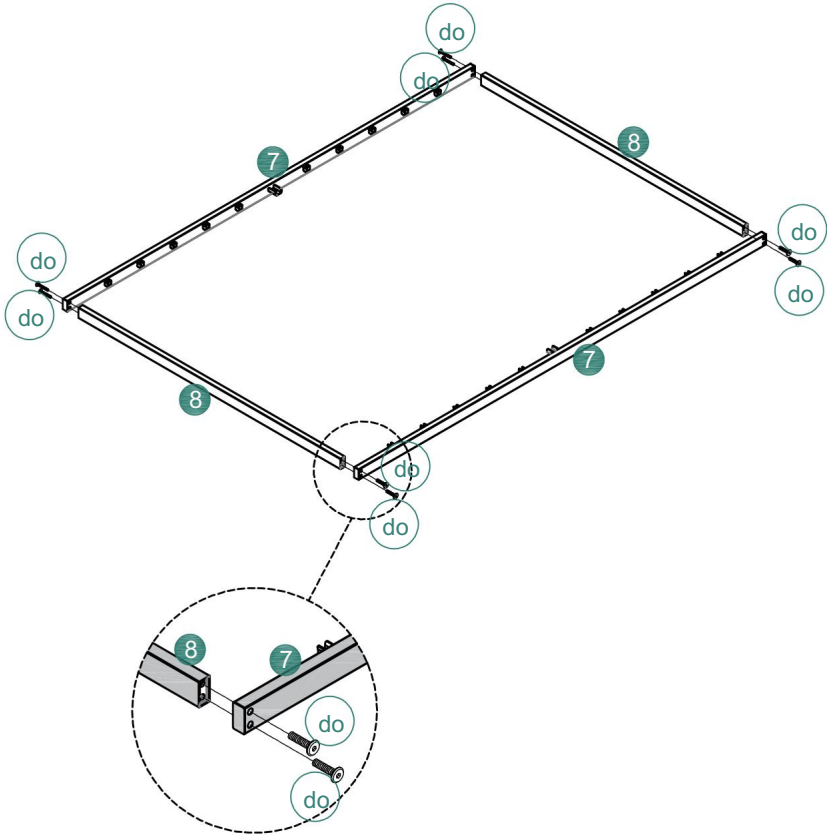

8



12x1



14x10



B x2



H

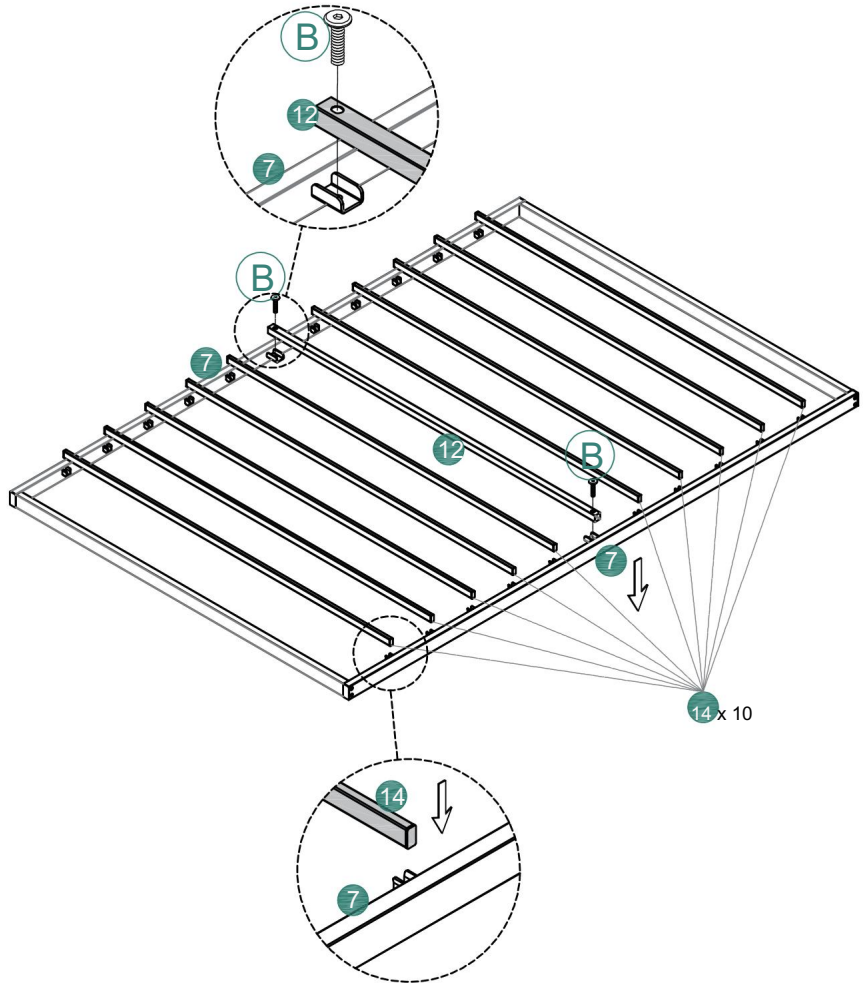

9



F x2



G x2 O

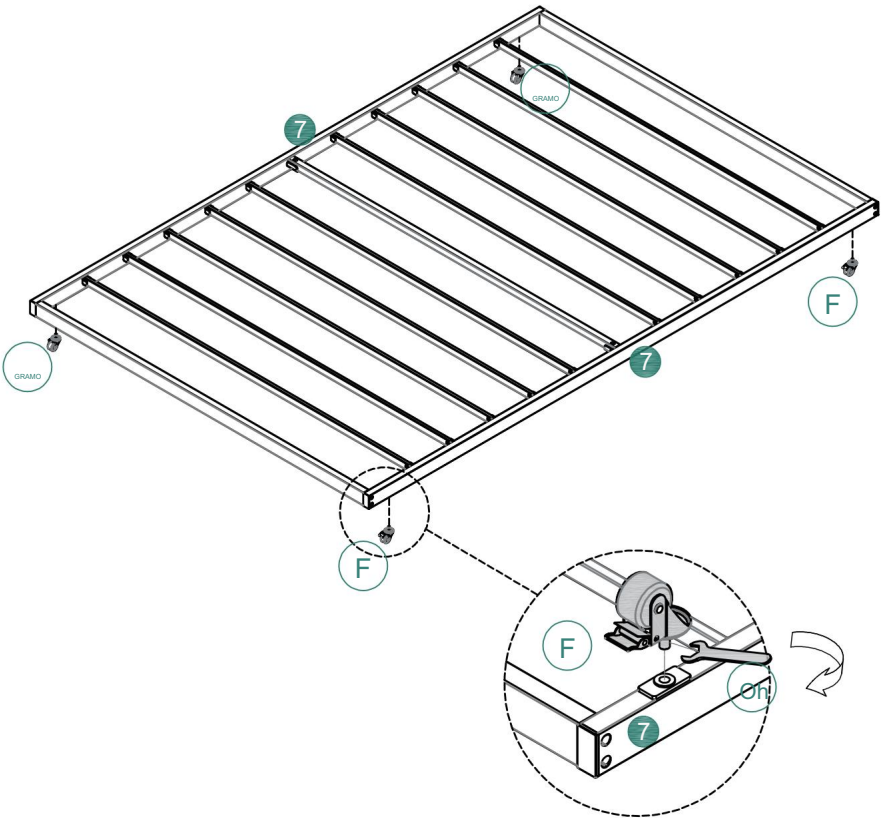

10

Método de montaje A

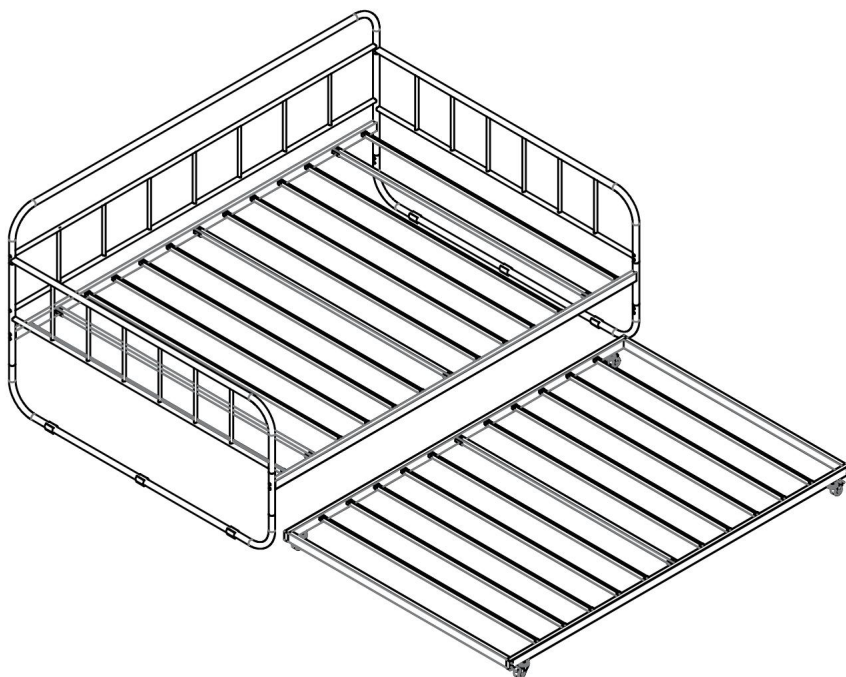

11

Compruebe y apriete todos los tornillos

Método de montaje B

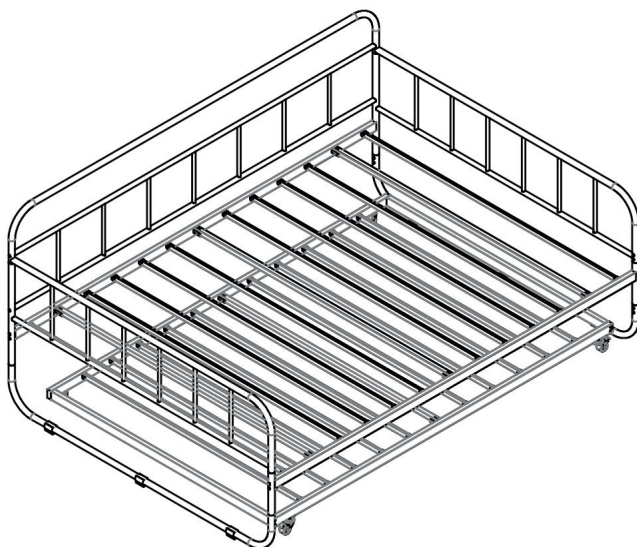

Fabricante: Shanghai muxin muyeyouxiangongsi Dirección:

Shuangchenglu 803nong11hao1602A-1609shi, baoshanqu, shanghai 200000 CN.

Importado a AUS: SIHAO PTY LTD. 1 ROKEVASTREETEASTWOOD

NSW 2122 Australia

Importado a EE. UU.: Sanven Technology Ltd. Suite 250, 9166 Anaheim Place, Rancho

Cucamonga, CA 91730



E-CrossStu GmbH

Mainzer Landstr.69, 60329 Fráncfort del Meno.



YH CONSULTING LIMITADA.

C/O YH Consulting Limited Oficina 147, Centurion House,

London Road, Staines-upon-Thames, Surrey,

TW18 4AX



VEVOR

Affordable. Reliable. Home Improvement.

GIORNALIERI

MODELLO:YJX-BF-001

VEVOR

Affordable. Reliable. Home Improvement.

DIVANI LETTI

MODELLO: YJX-BF-001

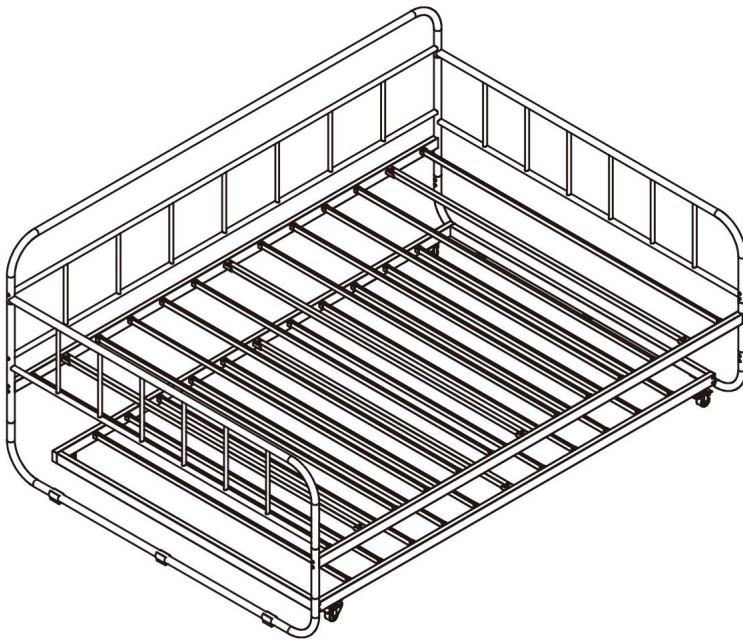

Queste sono le istruzioni originali, si prega di leggere attentamente tutte le istruzioni del manuale prima dell'uso. VEVOR si riserva la piena interpretazione del proprio manuale utente. L'aspetto del prodotto dipenderà dal prodotto ricevuto. Vi preghiamo di scusarci se non vi informeremo più in caso di aggiornamenti tecnologici o software sul nostro prodotto.

ISTRUZIONI DI SICUREZZA

AVVERTENZA:

leggere attentamente il presente documento prima di utilizzare il prodotto. La mancata osservanza di questa indicazione può causare gravi lesioni.

Precauzioni di montaggio 1.

Montare solo secondo queste istruzioni. Un montaggio improprio può creare pericoli.

2. Durante il montaggio, indossare occhiali di sicurezza approvati ANSI e guanti da lavoro resistenti.
3. Mantenere l'area di assemblaggio pulita e ben illuminata.
4. Tenere gli astanti fuori dall'area durante l'assemblea.
5. Non riunirsi se stanchi o sotto l'effetto di alcol, droghe o farmaci.
6. Le capacità del prodotto si applicano solo ai prodotti correttamente e completamente assemblati.
7. Montare su una superficie piana, livellata, dura e liscia, in grado di sostenere in modo sicuro i letti a baldacchino.
8. Se possibile, è possibile utilizzare utensili elettrici per facilitare il montaggio.
9. Per ulteriori informazioni riguardanti le parti elencate di seguito pagine, fare riferimento allo schema di montaggio di questo manuale. Disimballare e separare tutti i componenti in un'area di lavoro pulita.











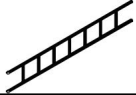









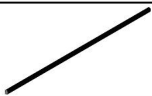

Precauzioni d'uso 1.

Non superare le capacità di peso specificate.

2. Utilizzare solo su una superficie piana, livellata, dura e liscia che possa essere utilizzata in sicurezza supportare letti a baldacchino completamente carichi.
3. Utilizzare solo come previsto.
4. Ispezionare prima di ogni utilizzo; non utilizzare se alcune parti sono allentate o danneggiate.

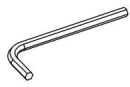
CONSERVARE QUESTO MANUALE

ELENCO DEI PEZZI

Articolo NO.	Riferimento Immagine	Quantità	Articolo n.	Riferimento Immagine	Quantità
①		X1	⑧		X2
②		X1	⑨		X2
③		X1	⑩		X2
④		X1	⑪		X3
⑤		X2	⑫		X1
⑥		X2	⑬		X10
⑦		X2	⑭ ○		X10
UN	 M8*15	X12	F		X2
B	 M8*30	X8	G		X2
C	 M8*40	X8	H	 M5	X1
D	 M8*50	X16	O		X1
E		X16			

VISTA ESPLOSA

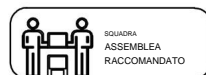
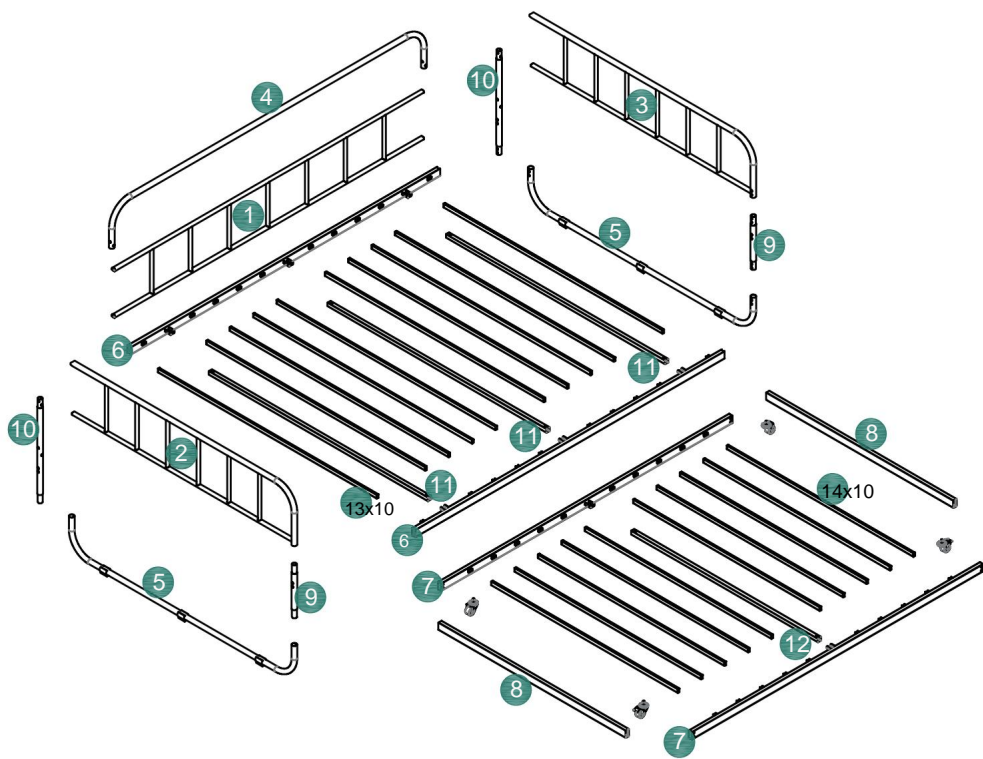

FASE DI MONTAGGIO

1



5 x2



9 x2



10x2



M8*15
UN x8

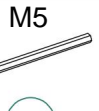

M5
H

Nota: Per facilitare installazione, si prega di bloccare le viti al 70% durante l'installazione.

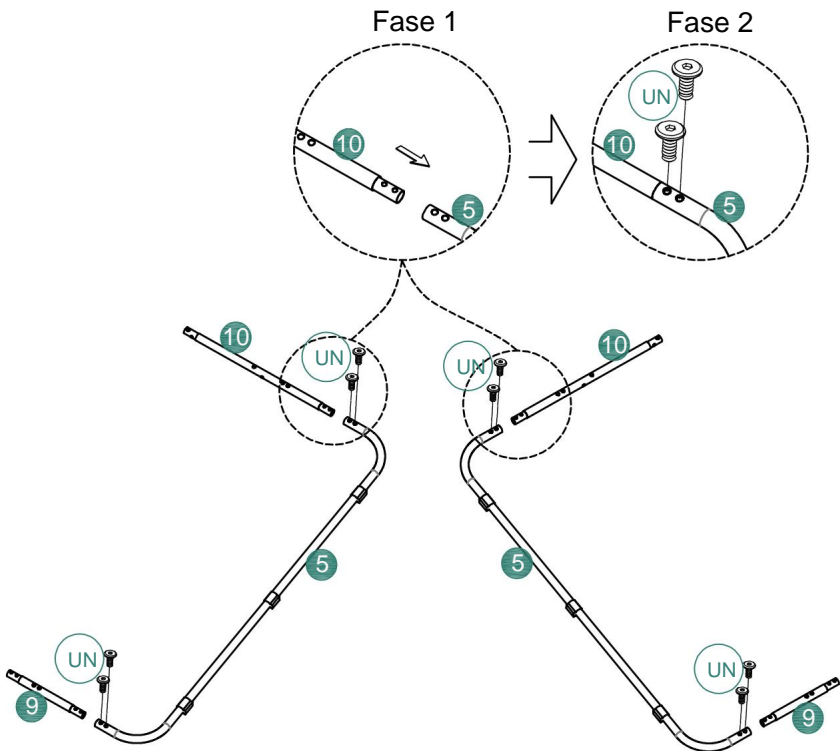

2



6 x 2

M8*50



D x 8



E x 8

M5



H

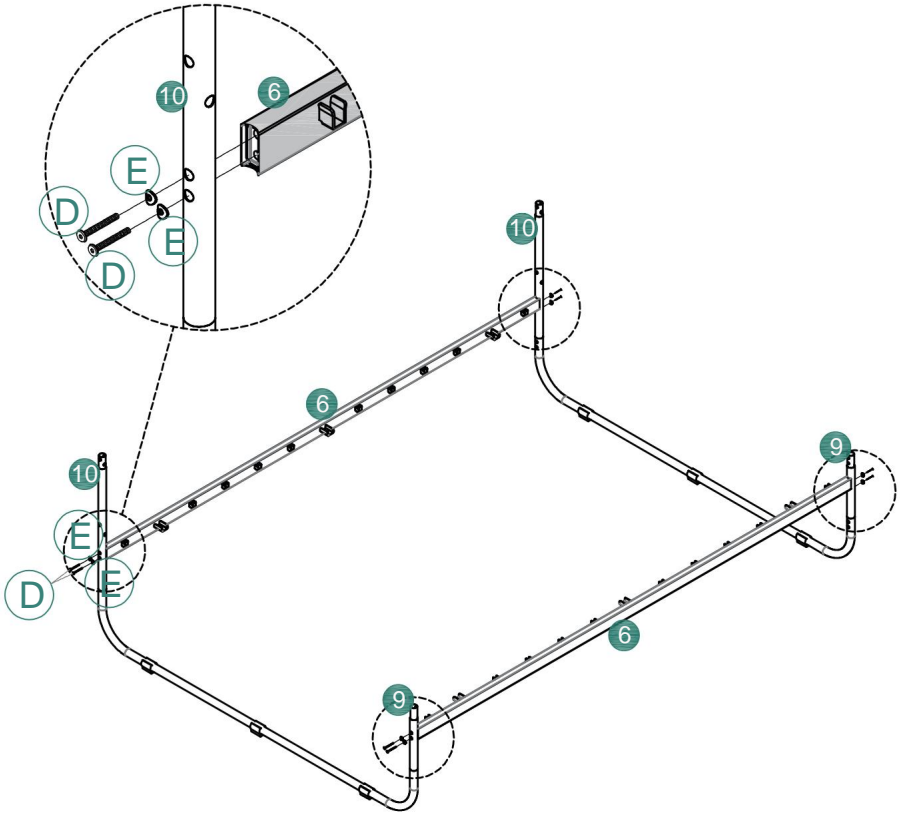

3



1 x1



4 x1



D x4



E x4

M5



H

Fase 1

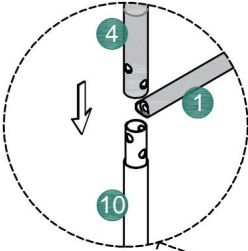

Fase 2

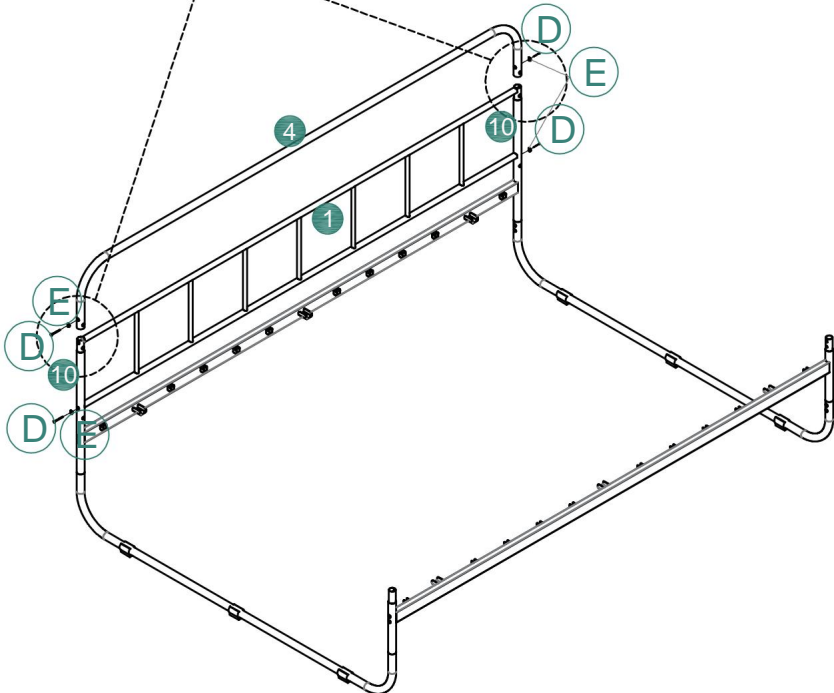
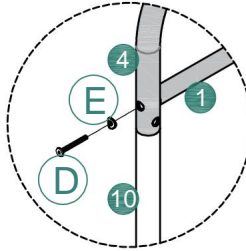

5



11x3

M8*30



B x6

M5



H

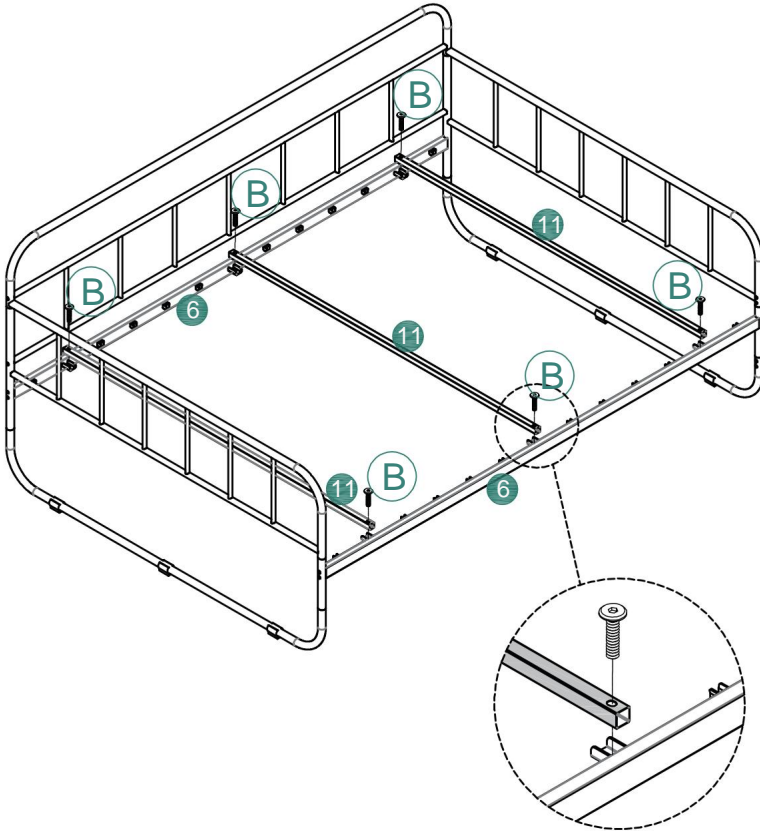

6

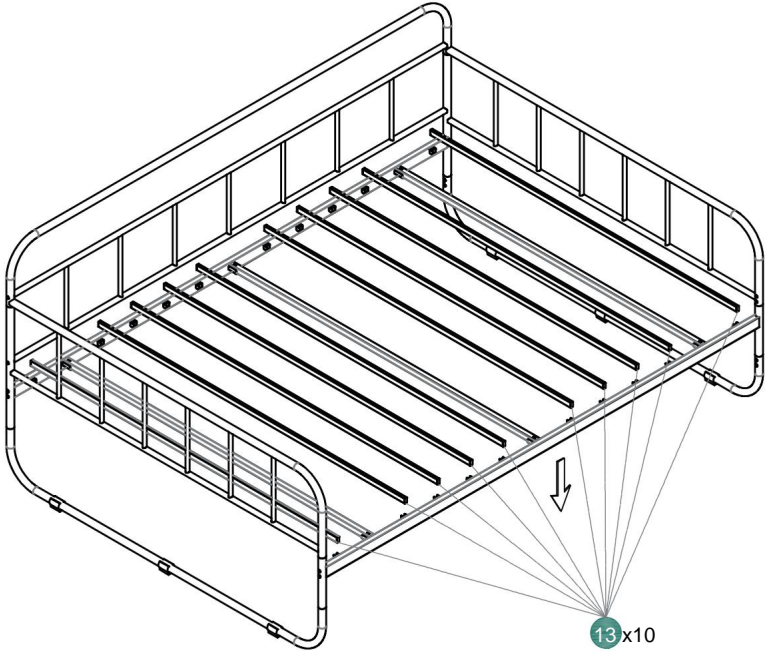
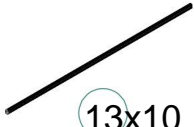

7



7 x2



8 x2

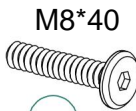

C x8

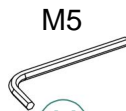

H

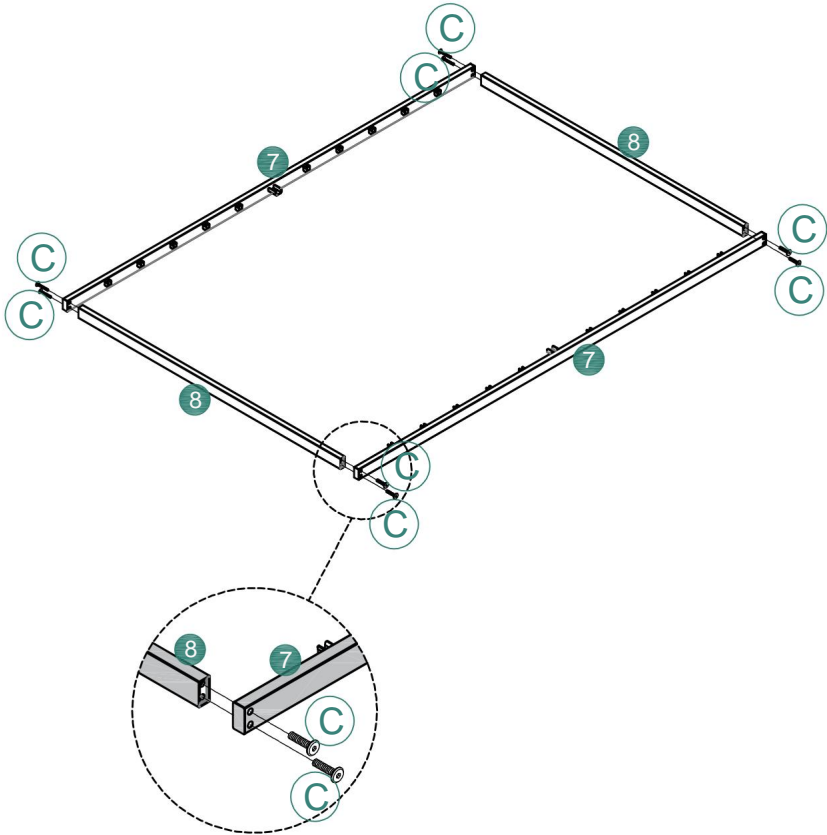

8



12x1



14x10



B
x2



H

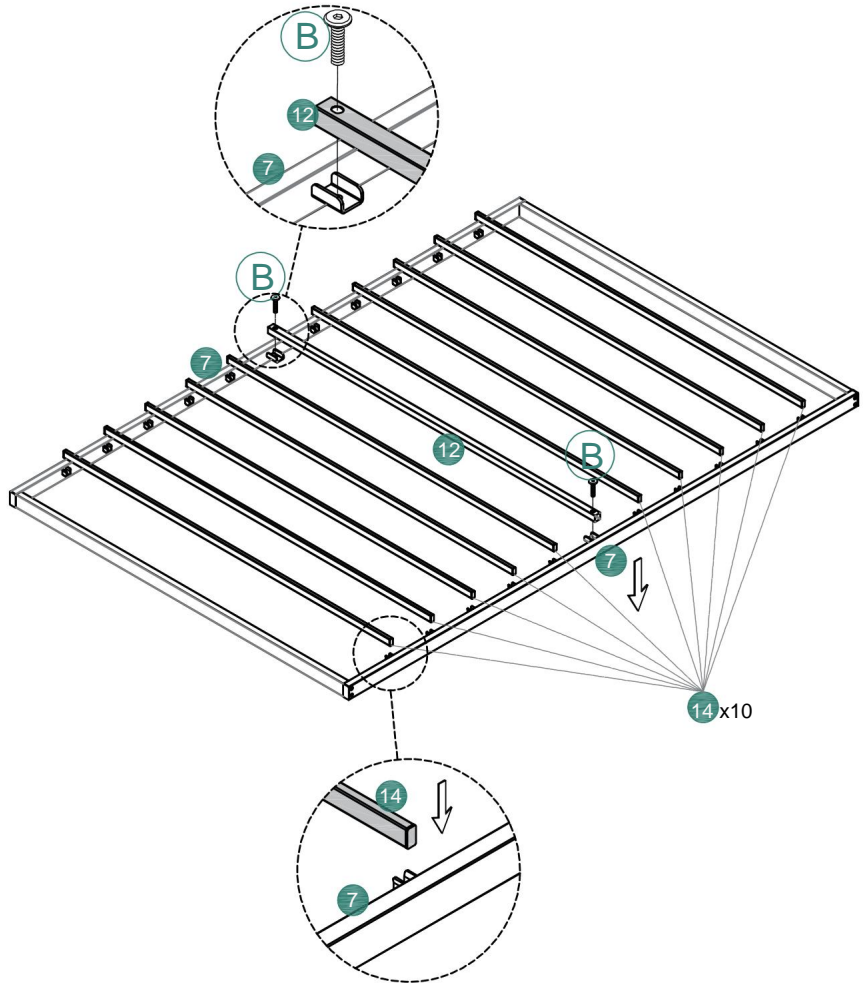

9



F x2



SØl x2



O

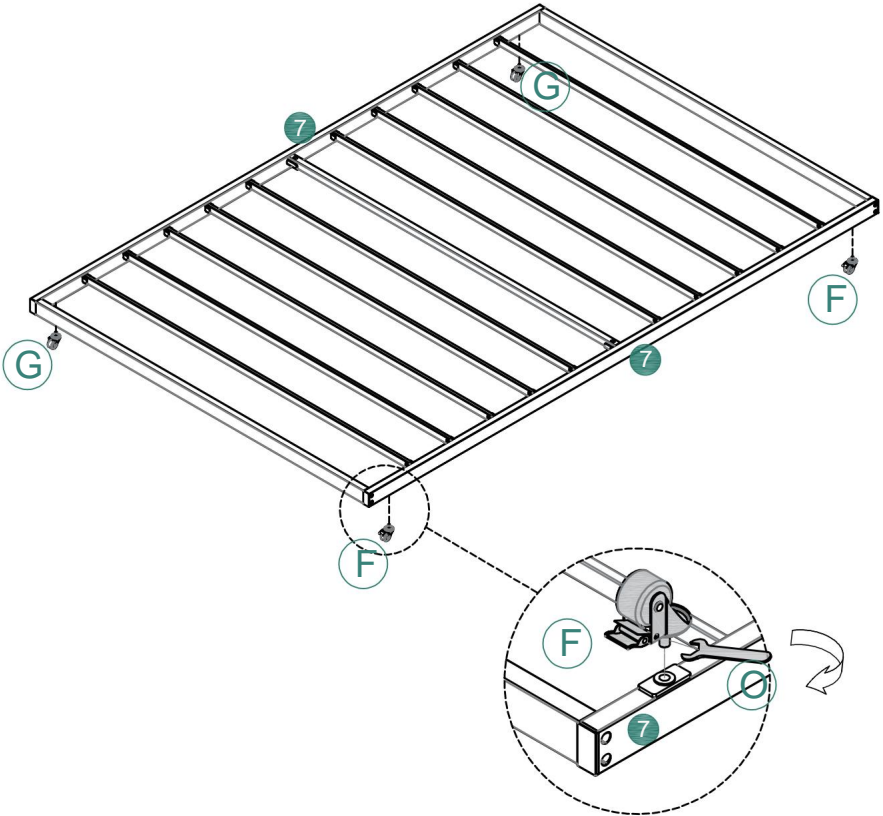

10

Metodo di assemblaggio A

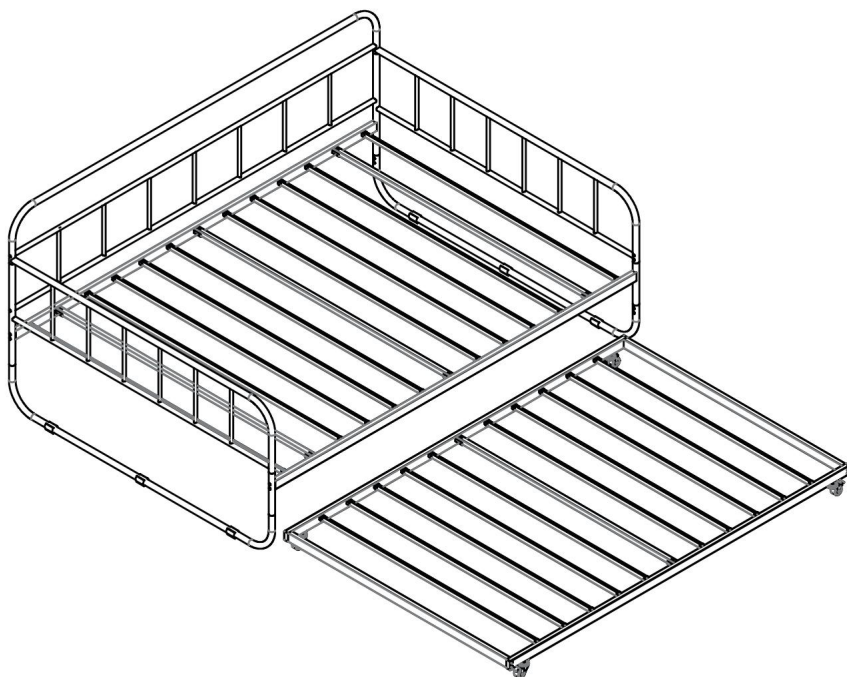

11

Controllare e serrare tutte le viti

Metodo di assemblaggio B

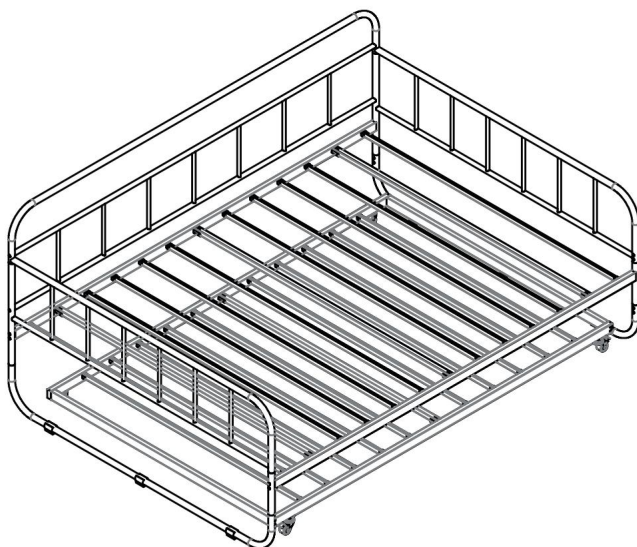

Produttore: Shanghaimuxinmuyeyouxiangongsi Indirizzo:

Shuangchenglu 803nong11hao1602A-1609shi, baoshanqu, shanghai 200000 CN.

Importato in AUS: SIHAO PTY LTD. 1 ROKEVASTREETEASWOOD

NSW 2122 Australia

Importato negli USA: Sanven Technology Ltd. Suite 250, 9166 Anaheim Place, Rancho

Cucamonga, CA 91730



E-CrossStu GmbH

Mainzer Landstr.69, 60329 Francoforte sul Meno.



YH CONSULTING LIMITED.

C/O YH Consulting Limited Ufficio 147, Centurion House,

London Road, Staines-upon-Thames, Surrey,

TW18 4AX



VEVOR

Affordable. Reliable. Home Improvement.

ŁÓŻKA DZIENNE

MODEL:YJX-BF-001

VEVOR

Affordable. Reliable. Home Improvement.

ŁÓŻKA DZIENNE

MODEL: YJX-BF-001

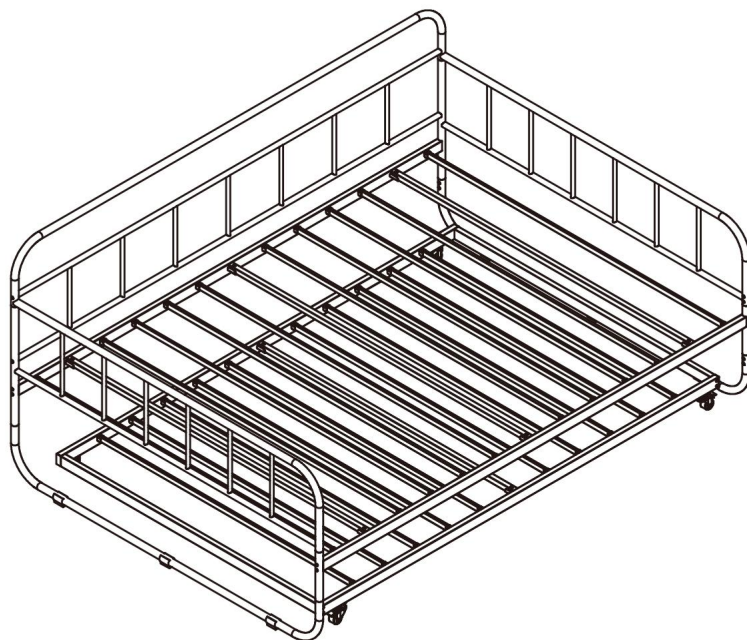

To jest oryginalna instrukcja obsługi. Przed użyciem prosimy o dokładne zapoznanie się z treścią instrukcji. Firma VEVOR zastrzega sobie prawo do jednoznacznej interpretacji niniejszej instrukcji obsługi. Wygląd produktu zależy od stanu, w jakim go otrzymali Państwo. Prosimy o wyrozumiałość, ale nie będziemy Państwa ponownie informować o aktualizacjach technologicznych lub oprogramowania naszego produktu.

INSTRUKCJE BEZPIECZEŃSTWA

OSTRZEŻENIE:

Przed użyciem produktu należy zapoznać się z niniejszym dokumentem. Nieprzestrzeżenie tego zalecenia może spowodować poważne obrażenia.

Środki ostrożności podczas

montażu 1. Montaż należy wykonywać wyłącznie zgodnie z niniejszą instrukcją. Nieprawidłowy montaż może stwarzać zagrożenie.

2. Podczas montażu należy nosić okulary ochronne zatwierdzone przez ANSI oraz wytrzymałe rękawice robocze.

3. Utrzymuj miejsce zgromadzenia w czystości i dobrym oświetleniu.

4. Podczas montażu nie dopuść, aby osoby postronne znajdowały się w pobliżu miejsca montażu.

5. Nie należy gromadzić się, jeśli jest się zmęczonym lub pod wpływem alkoholu, narkotyków lub narkotyków lub leków.

6. Możliwości produktu odnoszą się wyłącznie do produktów prawidłowo i całkowicie zmontowanych.

7. Zmontuj na płaskiej, równej, twardej i gładkiej powierzchni, która będzie w stanie bezpiecznie utrzymać łóżko z baldachimem.

8. Jeżeli to możliwe, możesz użyć elektronarzędzi, aby ułatwić montaż.

9. Aby uzyskać dodatkowe informacje dotyczące części wymienionych poniżej,

Proszę zapoznać się ze schematem montażu w niniejszej instrukcji. Rozpakuj i oddziel wszystkie części w czystym miejscu pracy.

Zachowaj środki

ostrożności 1. Nie przekraczaj dopuszczalnego obciążenia.











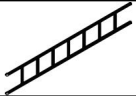











2. Używaj wyłącznie na płaskiej, równej, twardej i gładkiej powierzchni, która może być bezpiecznie używana. obsługuje w pełni załadowane łóżka z baldachimem.

3. Używać wyłącznie zgodnie z przeznaczeniem.

4. Przed każdym użyciem należy przeprowadzić kontrolę. Nie używać produktu, jeśli części są luźne lub uszkodzone.

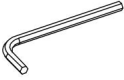
ZAPISZ TĘ INSTRUKCJĘ

LISTA CZĘŚCI

Przedmiot NIE.	Odniesienie Obraz	Ilość Nr artykułu	Odniesienie Obraz	Ilość
①		X1	⑧ 	X2
②		X1	⑨ 	X2
③		X1	⑩ 	X2
④		X1	⑪ 	X3
⑤		X2	⑫ 	X1
⑥		X2	⑬ 	X10
⑦		X2 14	○ 	X10
A	 M8*15	X12	F 	X2
B	 M8*30	X8	G 	X2
C	 M8*40	X8	H  M5	X1
D	 M8*50	X16	O 	X1
mi		X16		

WIDOK ROZBITY

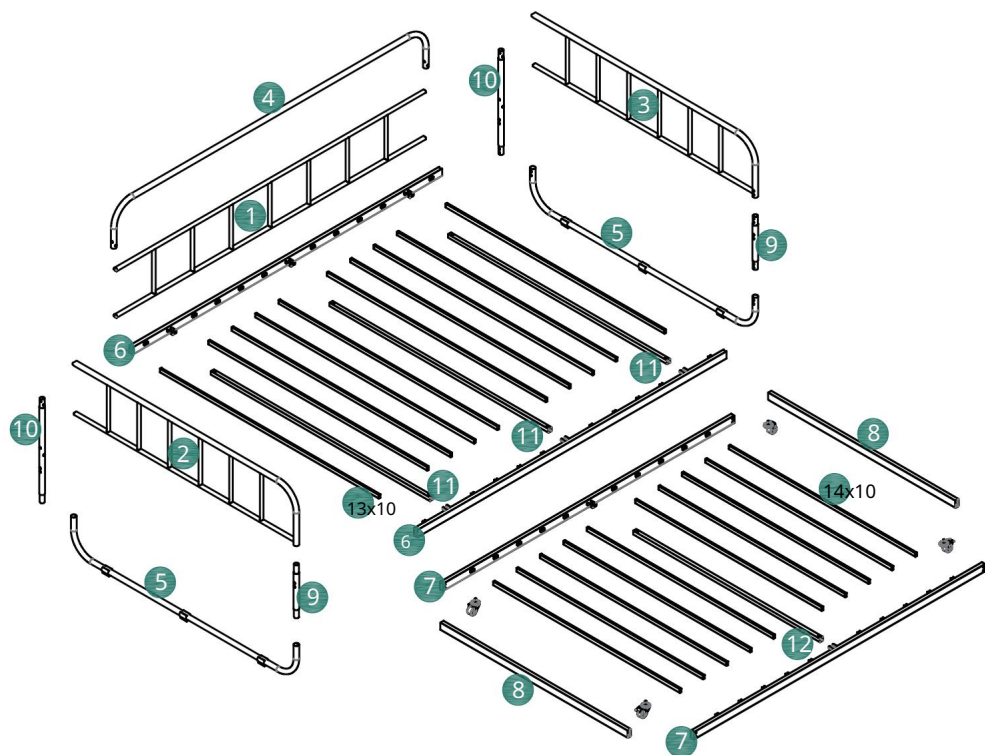

KROK MONTAŻU

1



5 x2



9 x2

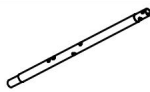

10 x2

M8*15



x8

M5



H

Uwaga: Aby ułatwić podczas montażu proszę zablokować śruby na 70% podczas instalacji.

Krok 1

Krok 2

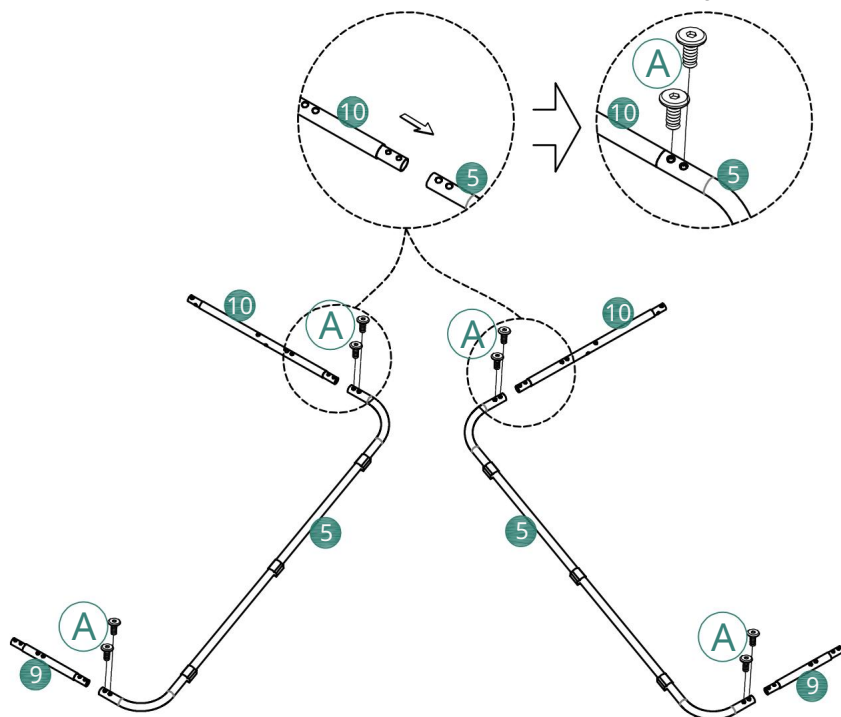

2



6 x 2



D x 8



E x 8

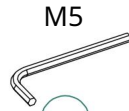

M5

H

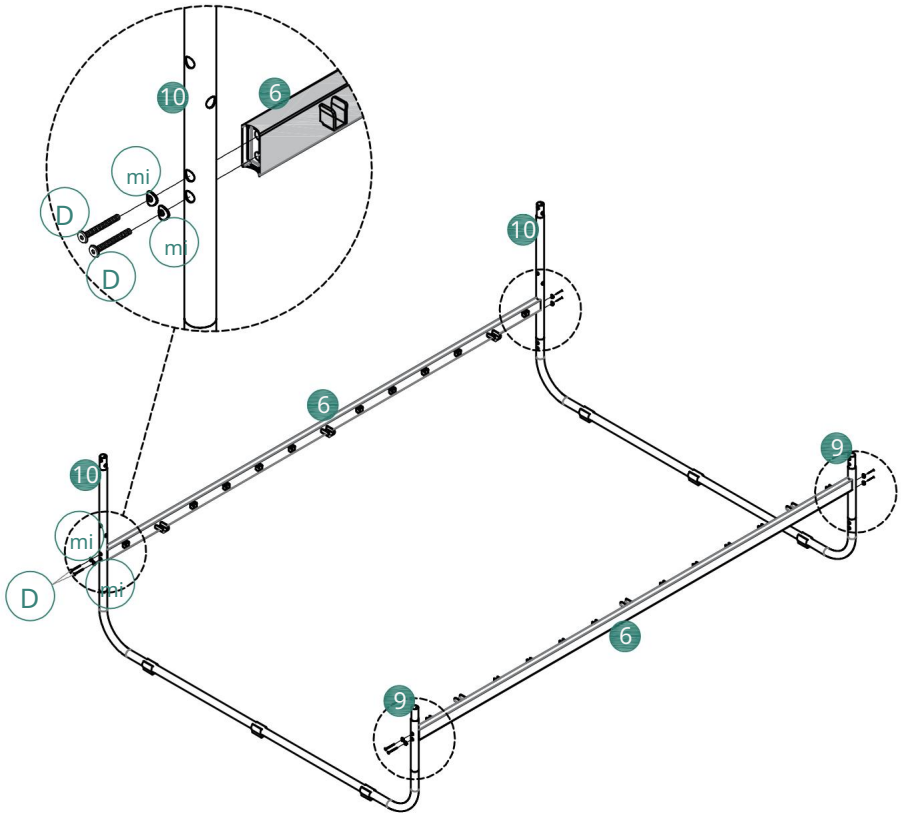

3



1 x1



4 x1

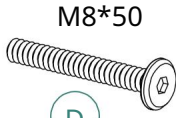

D x4



E x4

M5



H

Krok 1

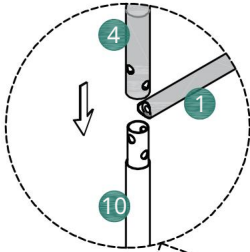

Krok 2

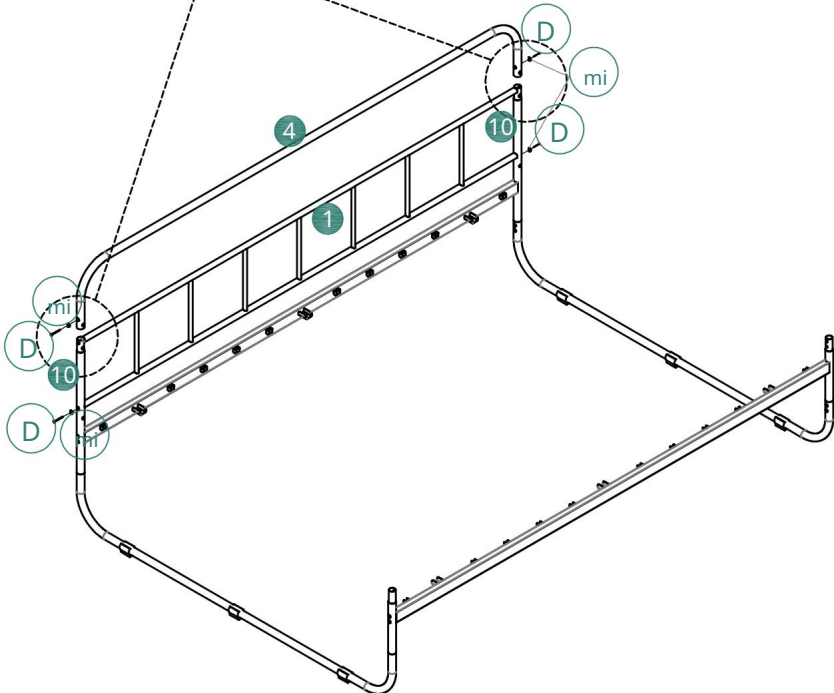
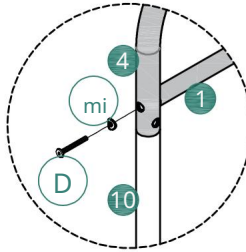

4

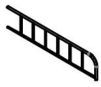

2 x1

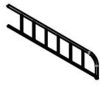

3 x1



x4

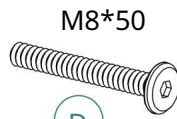

D x4



E x4

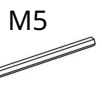

H

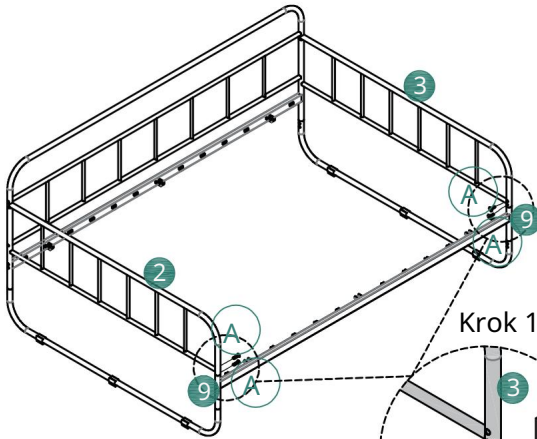

Krok 1

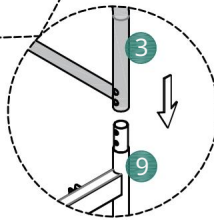

Krok 2

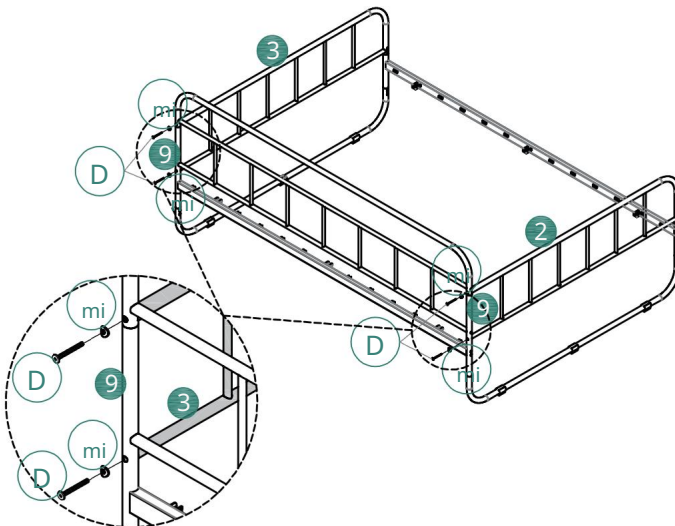
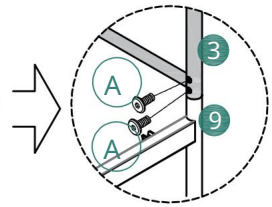

5



11x3

M8*30



B x6

M5



H

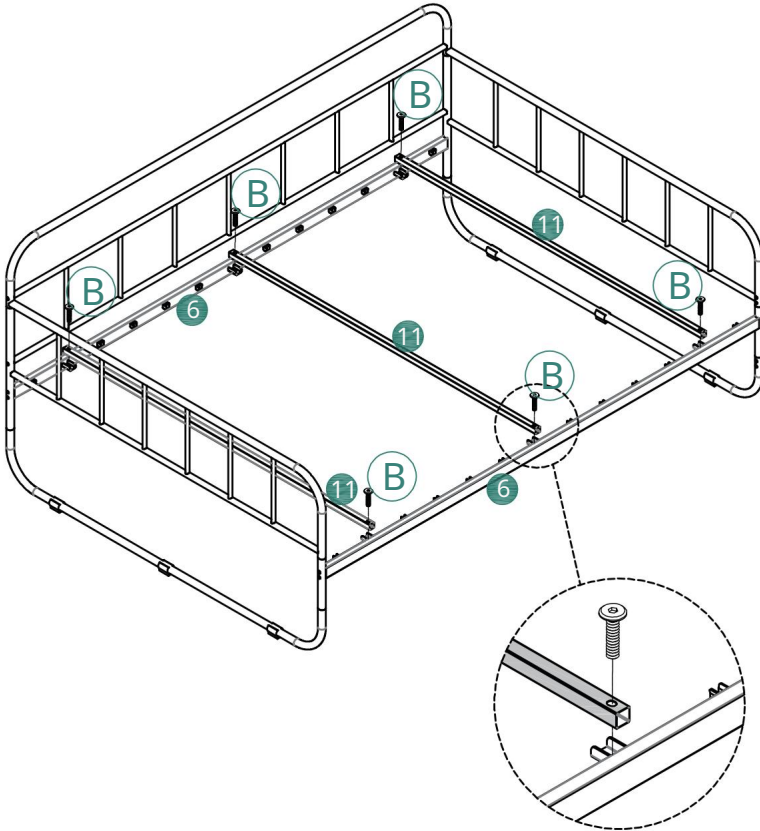

6

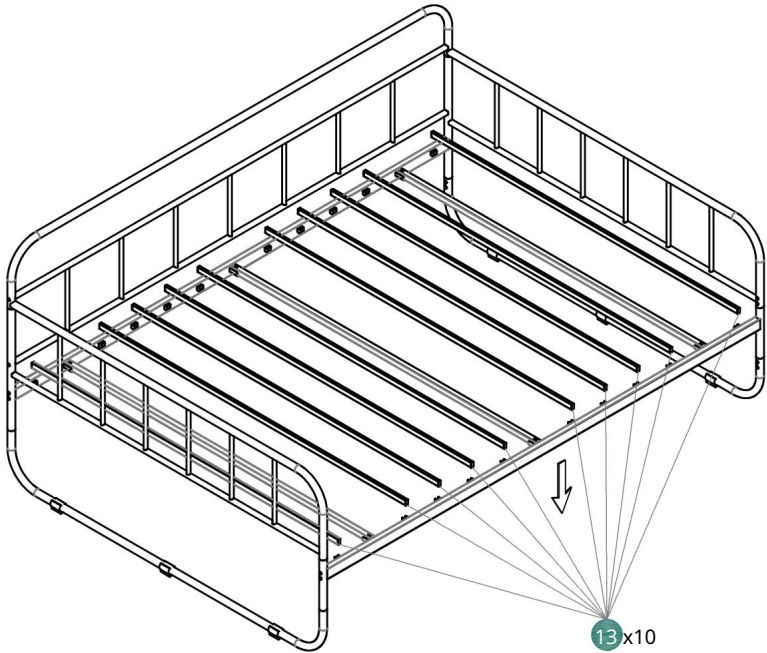
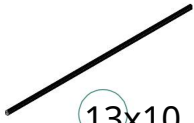

7



7
x2



8
x2



C
x8



H

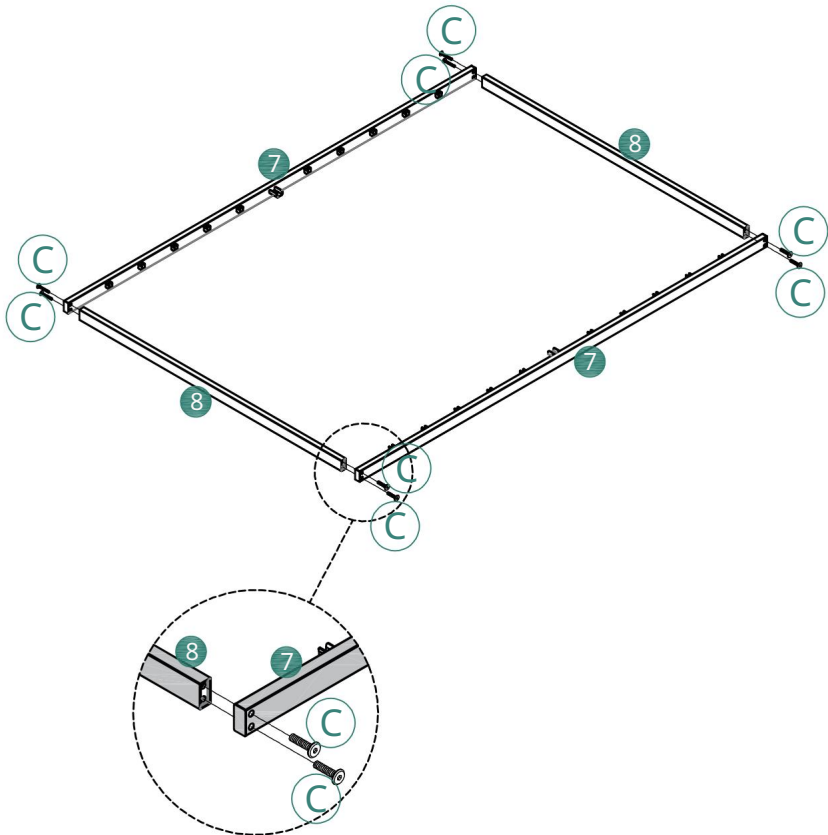

8



12x1



14x10



M8*30

B x2



M5

H

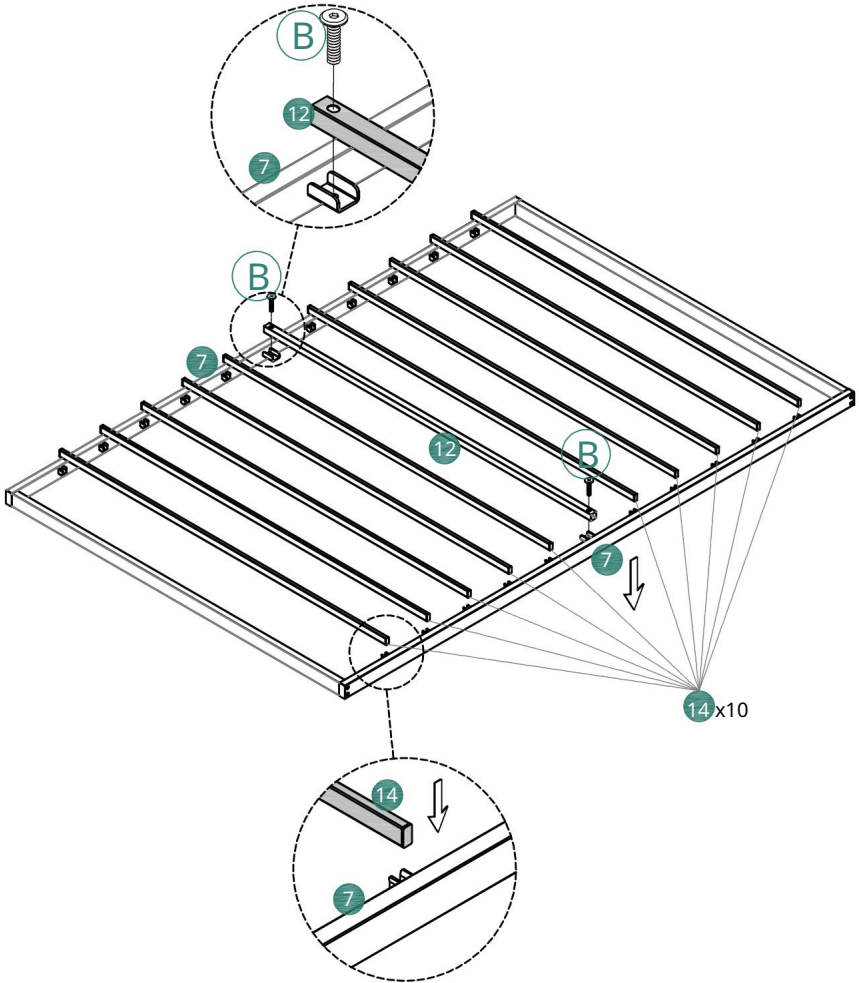

9



F x2



G x2 O

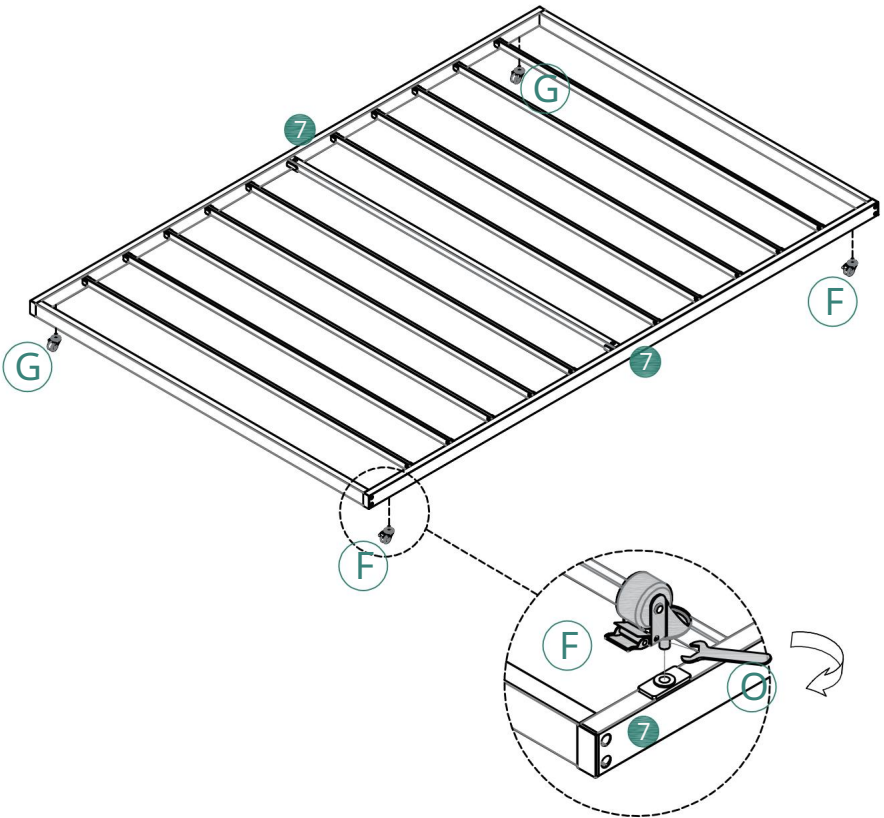

10

Metoda montażu A

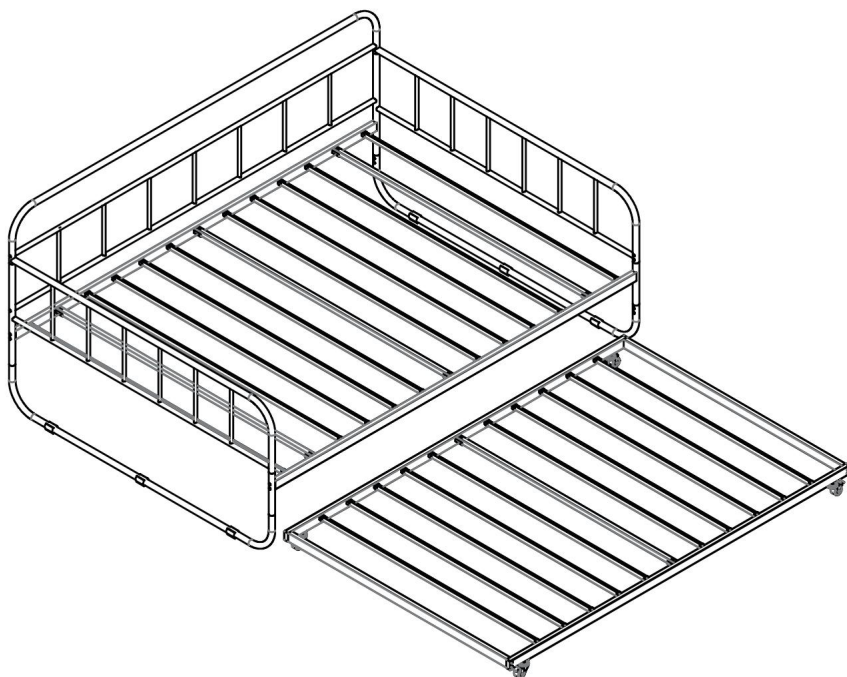

11

Sprawdź i dokręć wszystkie śruby

Metoda montażu B

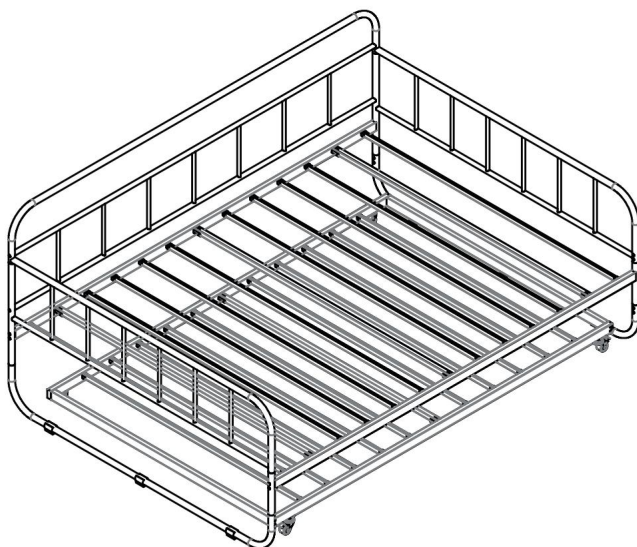

Producent: Shanghaimuxinmuyeyouxiangongsi Adres:

Shuangchenglu 803nong11hao1602A-1609shi, baoshanqu, szanghaj 200000 CN.

Importowane do AUS: SIHAO PTY LTD. 1 ROKEVASTREETEASTWOOD

NSW 2122 Australia

Importowane do USA: Sanven Technology Ltd. Suite 250, 9166 Anaheim Place, Rancho Cucamonga, CA 91730



E-CrossStu GmbH

Mainzer Landstr.69, 60329 Frankfurt nad Menem.



YH CONSULTING LIMITED.

C/O YH Consulting Limited Biuro 147, Centurion House, London Road, Staines-upon-Thames, Surrey, TW18 4AX

