

ASSEMBLY INSTRUCTIONS

Desk

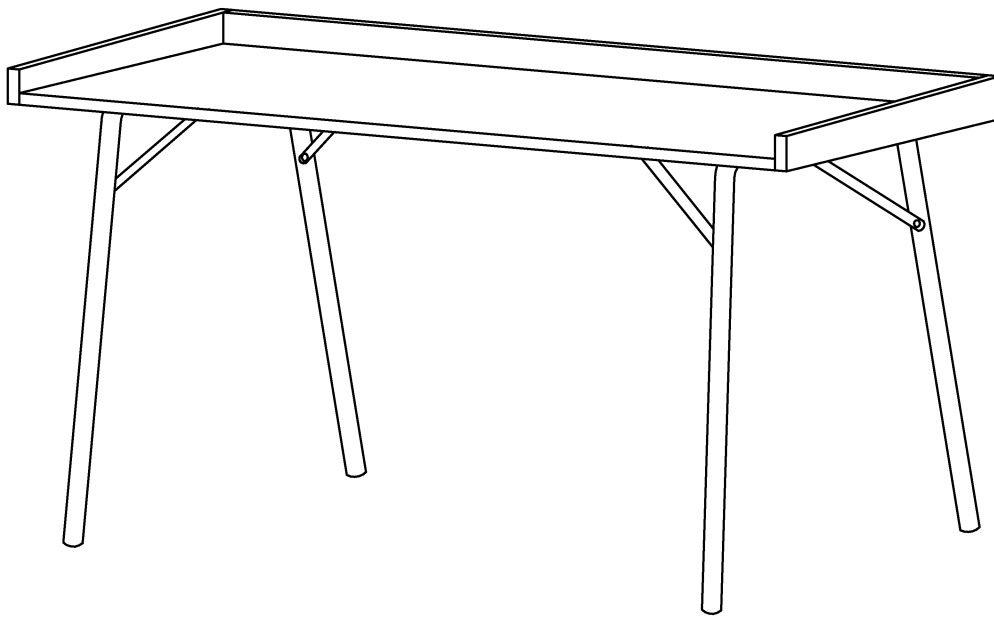

NOTE TO CUSTOMERS:

- For ease and speed of assembly we recommend that before you commence each step of the assembly that you identify all the parts required to complete that step.
- We recommend that where possible you allow sufficient space to assemble the item as close as possible to the place where it will be once assembled.
- For the protection of your furniture we recommend that the product is placed on protected surfaces during assembly to prevent any damage.
- During assembly do not over tighten, as this may damage the product.
- Please ensure you retain all the product packaging until the item completely assembled.
- Please periodically check all fittings and re-tighten as necessary.
- Please never allow any liquids to remain on your furniture as absorption can cause the wood to warp or finish to de-laminate.
- It is recommended that this item should be assembled by two adults.

To use a cam lock: (Please read below instructions before assembling)







		<p>1. Insert cam screw into hole as shown in diagram A .</p>
		<p>Make sure not to insert the cam screw: Too deep as shown in figure B as this will cause the cam screw to be misaligned and unable to interlock properly.</p>
		<p>Also avoid inserting the cam screw too close to the surface of the hole as shown in figure C, as this will cause the cam lock to be too loose, and not interlock properly.</p>

	<p>2. Connect the panels together.</p>
	<p>3. When inserting the cam lock make sure the arrow of the cam lock faces the cam screw.</p>
	<p>4. To tighten the cam lock turn the cam lock clockwise 90-180 degree or until the arrow is facing opposite the place cam lock was inserted.</p>
<p>NOTE: DO NOT USE AN AUTOMATIC SCREWDRIVER TO TIGHTEN CAM LOCKS.</p>	



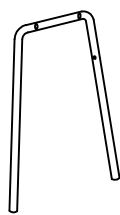

Note:

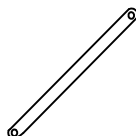
- Read these instructions carefully before assembling.
- Tools required : Phillips screwdriver, flat screwdriver.
- Find a clean, smooth area on which to work , such as a carpet, in order to avoid scratching the wood surfaces.
- Wait to dispose of the packing material until assembly is complete and all parts and hardware are accounted for.
- Two or more people might be required for assembly.

Part List

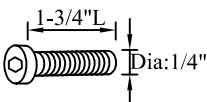
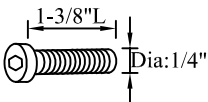
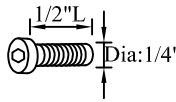
A1. Quantity of 1  Top Panel	A2. Quantity of 1  Apron	A3. Quantity of 1  Left Apron	A4. Quantity of 1  Right Apron
A5. Quantity of 2  Leg	A6. Quantity of 2  Connect Bar	A7. Quantity of 4  Connect Bar	

Hardware List

B1. Quantity of 4  Bolt	B2. Quantity of 4  Bolt	B3. Quantity of 8  Bolt	B4. Quantity of 6  Camlock
B5. Quantity of 3  Bolt	 Allen Wrench		

STEP 1

B5  3pcs

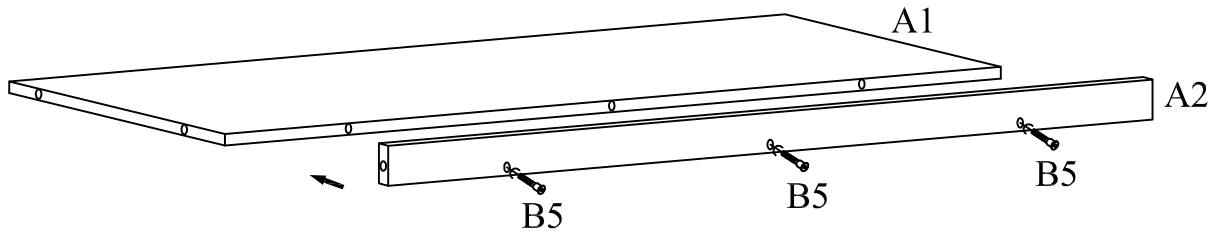

Assemble Apron A2 to Top Panel A1 using Bolts B5.

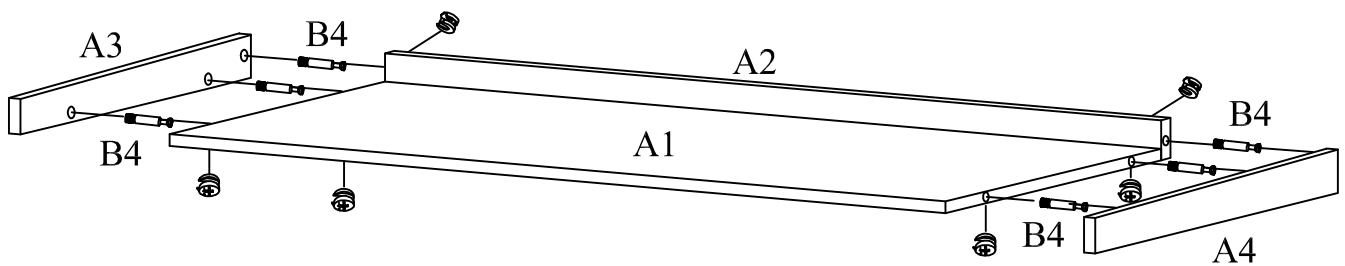

STEP 2

B4  6sets



Assemble Aprons A3&A4 to Apron A2 and Top Panel A1 using Camlocks B4.

STEP 3

B1		4pcs
B3		8pcs

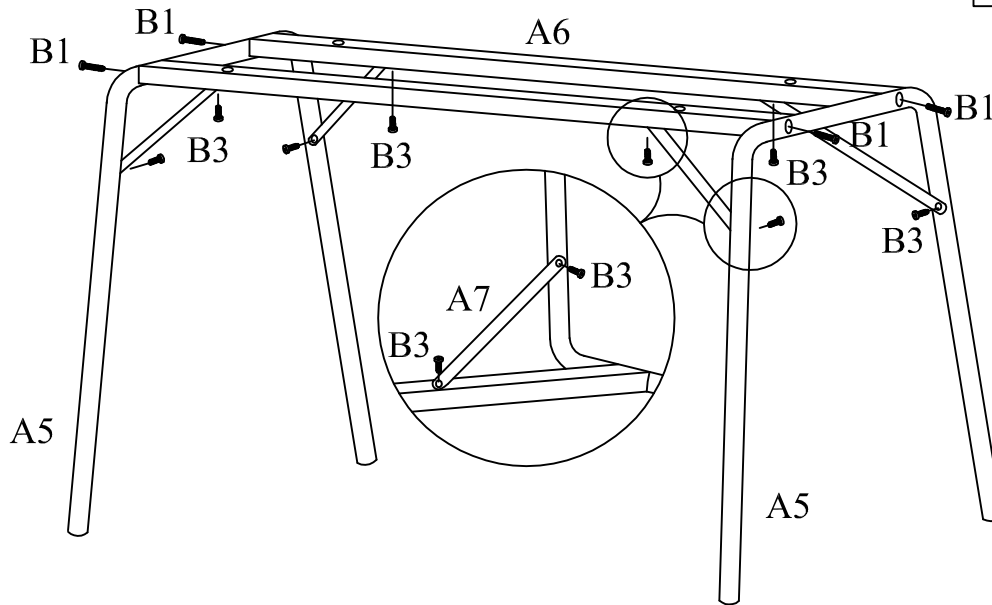

- 1). Assemble Legs A5 to Connect Bars A6 using Bolts B1.
 - 2). Assemble Connect Bars A7 to Legs A5 and Connect Bars A6 using Bolts B3.
- Noted: Please do not tighten Bolts B1 & B3 until Step 4.

STEP 4

B2		4pcs
----	---	------

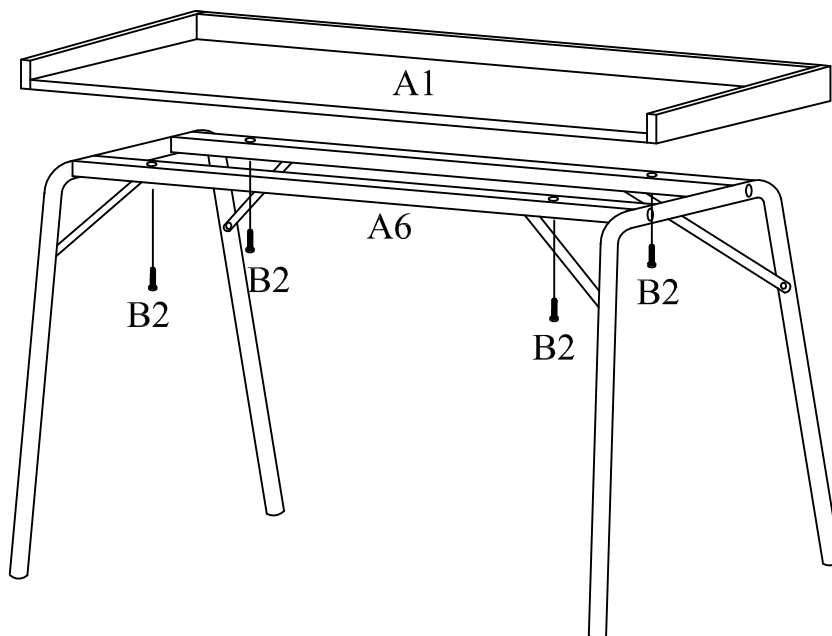

- Assemble Top Panel A1 to Connect Bars A6 using Bolts B2.
- Noted: Place unit on the floor and check if it is stable before tightening all bolts.