







ASSEMBLY INSTRUCTIONS & PARTS IDENTIFICATION END TABLE

Thank you for purchasing this quality product. Be sure to check all packing material carefully for small parts that may have come loose inside the carton during shipment.

Key Parts			
No	Code	Q'Ty	Description
1	A	1 pc	Table Top
2	B	2 pcs	Side Leg Assembly
3	C	2 pcs	Front Stretchers
4	D	4 pcs	Floor Glide
5	E	1 pc	Drawer Complete
6	F	1 pc	Drawer Glide
7	G	1 Set	Drawer Pull w/ Screw
8	H	1 Pc	Drawer Stop
9	I	1 Set	Electric Outlet

Hardware kit			
No		Description	Q'Ty
A		Long Bolt Ø7.8 x 50mm	4 pcs
B		Lock Washer Ø8.5	12 pcs
C		Flat Washer Ø8.5	8 pcs
D		Allen Key	1 pc
E		Dowel Ø10 x 40mm	4 pcs
F		Short Bolt Ø6.3 x 35mm	8 pcs
G		Curved Washer	4 pcs

- Carefully lay the Storage box upside down on a smooth flat surface to prevent scratches.
- Insert a Dowel (E) to Front Facing Side Stretchers. Detail A
- Attach Side Leg Assembly to Table Top and Front Stretchers by the following two steps:
- Insert a Bolt (A) with Flat washer (C), Lock washer (B) through holes of Table Top corner. Detail C
- Remove drawer for access. Do not fully tighten.
- Insert a Bolt (F) with Curved washer (G), and a Lock washer (B) through holes in the Stretchers. Detail B
- Securely tighten all bolts once all pieces are in place. Replace drawer.
- Carefully turn Side Table upright.

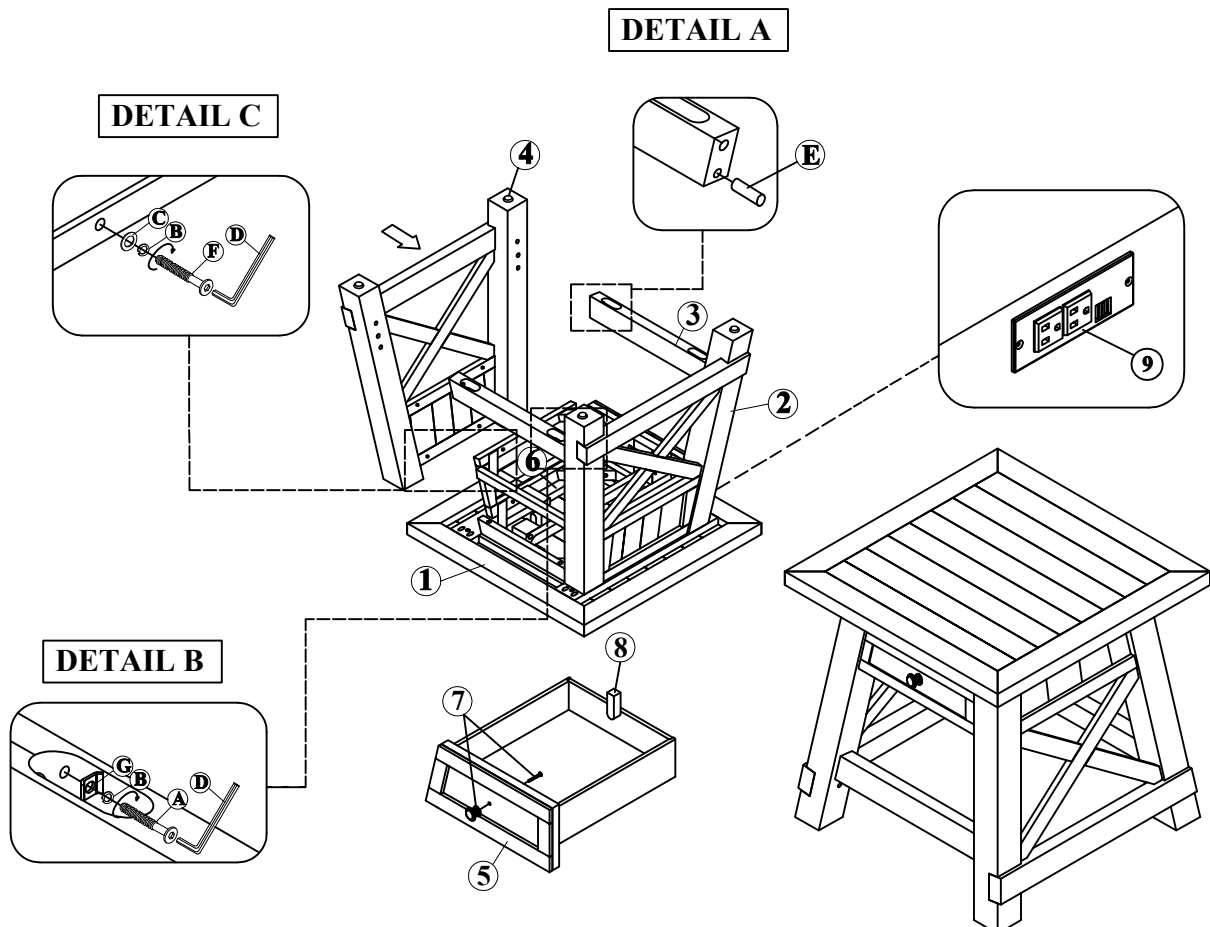

MADE IN VIETNAM