

**Important - Please read these instructions fully before starting assembly**



**SAFETY AND  
CARE ADVICE**



**NO POWER TOOLS**

**SAFETY AND CARE ADVICE**

- Check you have all the components and tools listed.
- Remove all fittings from the plastic bags and separate them into their groups.
- We do not recommend the use of power drills/drivers for inserting screws, as this could damage the unit. Only use hand screwdrivers and Allen keys.
- Keep children and animals away from the work area, small parts could cause choking if swallowed.
- Make sure you have enough space to lay out the parts before starting.
- Assemble the item as close to its final position (in the same room) as possible.
- Do not overtighten the nuts to avoid causing damage to the threads.
- Only clean using a damp cloth and mild detergent, do not use bleach or abrasive cleaners.
- From time to time check that there are no loose screws on this unit
- This product should not be discarded with household waste. Take to your local authority waste disposal centre

## IMPORTANT INFORMATION



30 MINUTE  
BUILD



ONE  
PERSON



MAXIMUM  
CAPACITY 30Kg

PLEASE CHECK CAREFULLY AND MAKE SURE YOU HAVE ALL FITTINGS AND TOOLS LISTED BELOW BEFORE YOU START.

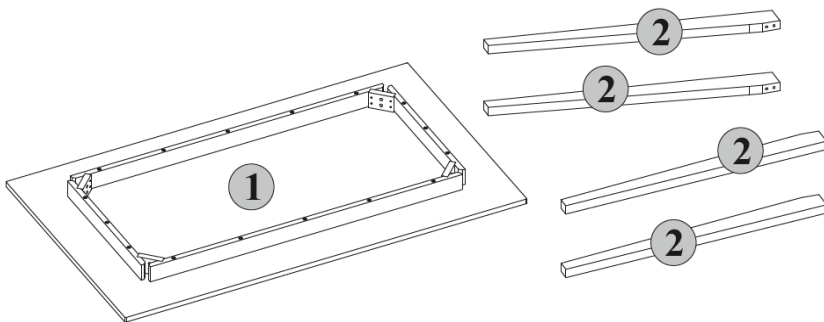
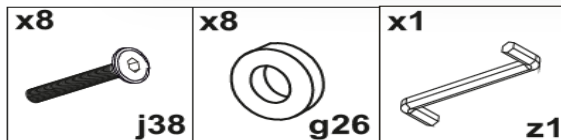

**NOTE:** The quantities above are the correct amount to complete the assembly. In some cases more fittings may be supplied than are required.

# STEP 1

Use a clean, flat, soft surface to avoid any bumps or scratches. Place your table top face-down.

Attach each of the 4x legs [2] to the table top. Position the leg against the table top frame and align the pre-drilled holes. Secure with 2x washers [g26] + bolts [j56] on each leg (8 in total). Tighten with Allen key [z1].

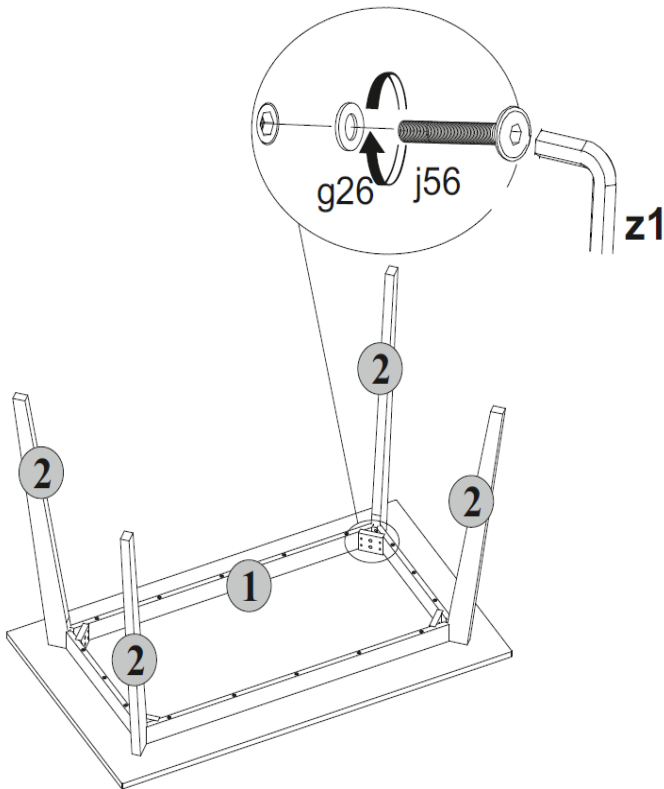

## STEP 2

Carefully, and with help, flip your table over so it rests on its legs. Check stability. Your table is now ready to use.

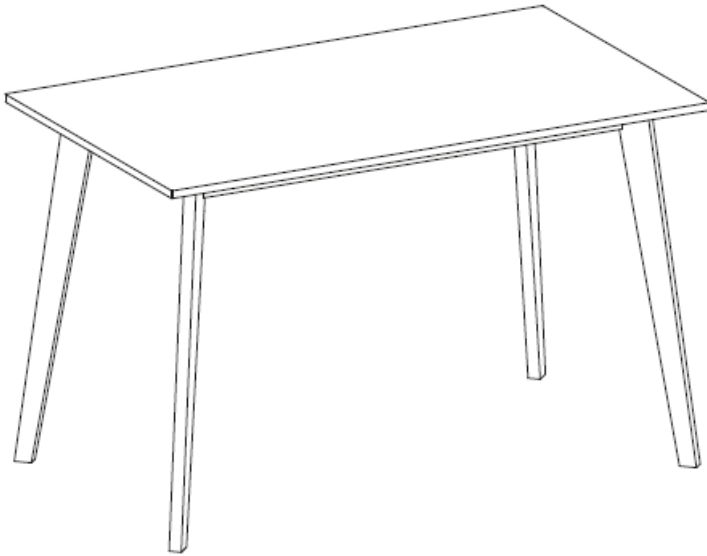



## OUR 2 YEAR GUARANTEE

our products come with a 1 year guarantee to give you peace of mind shopping at Furniturebox



## WHAT THE GUARANTEE COVERS

---



**PRE-INSERTED FIXINGS**  
e.g. loose metal threads



**FAULTY JOINTS**  
e.g. legs bending



**EXTERNAL FIXING FAULTS**  
e.g. metal discs removing from table top



**STRUCTURAL INTEGRITY**  
e.g. the frame of the product