

ASSEMBLY

Instructions

HBLJ-V1

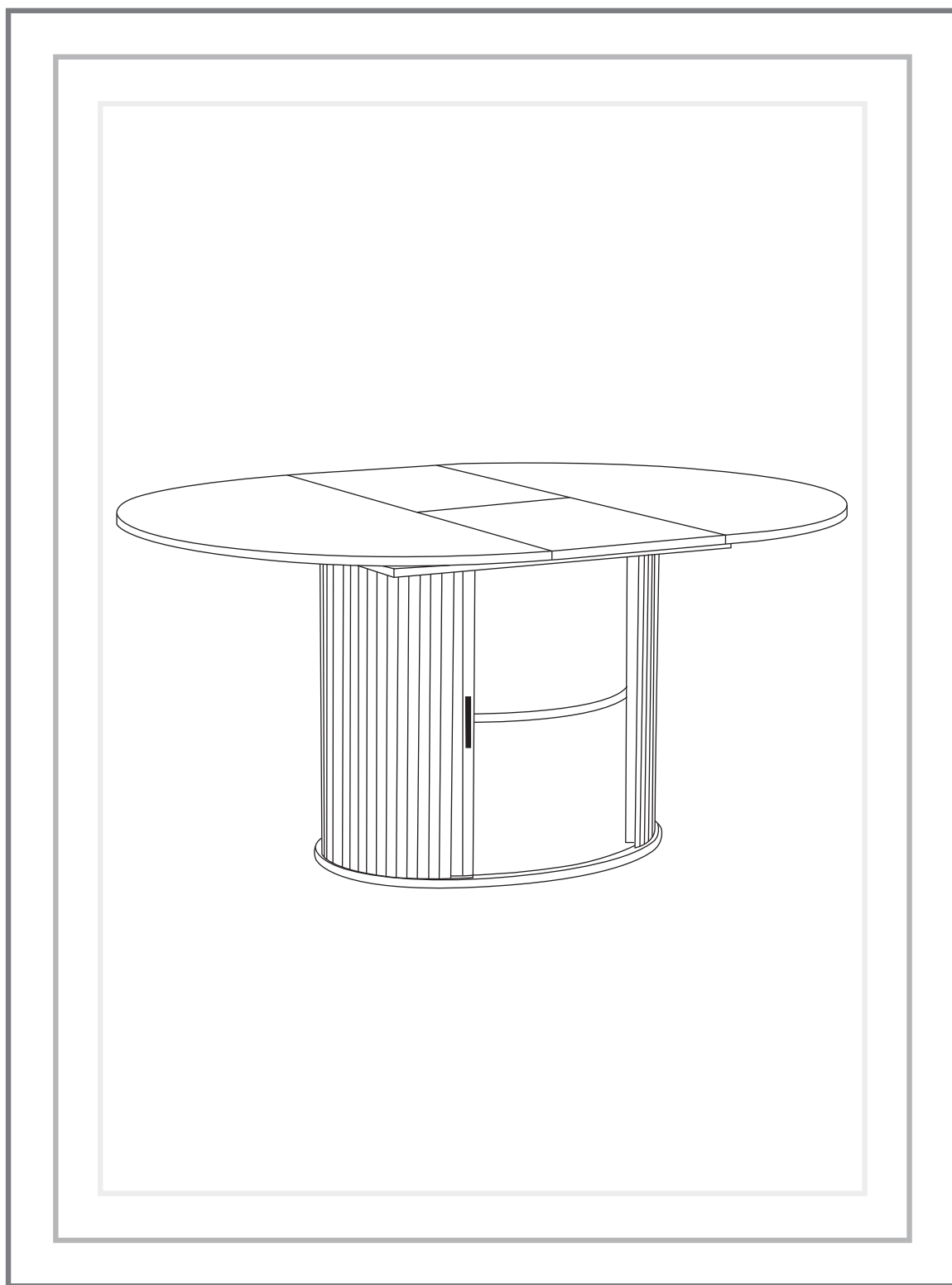





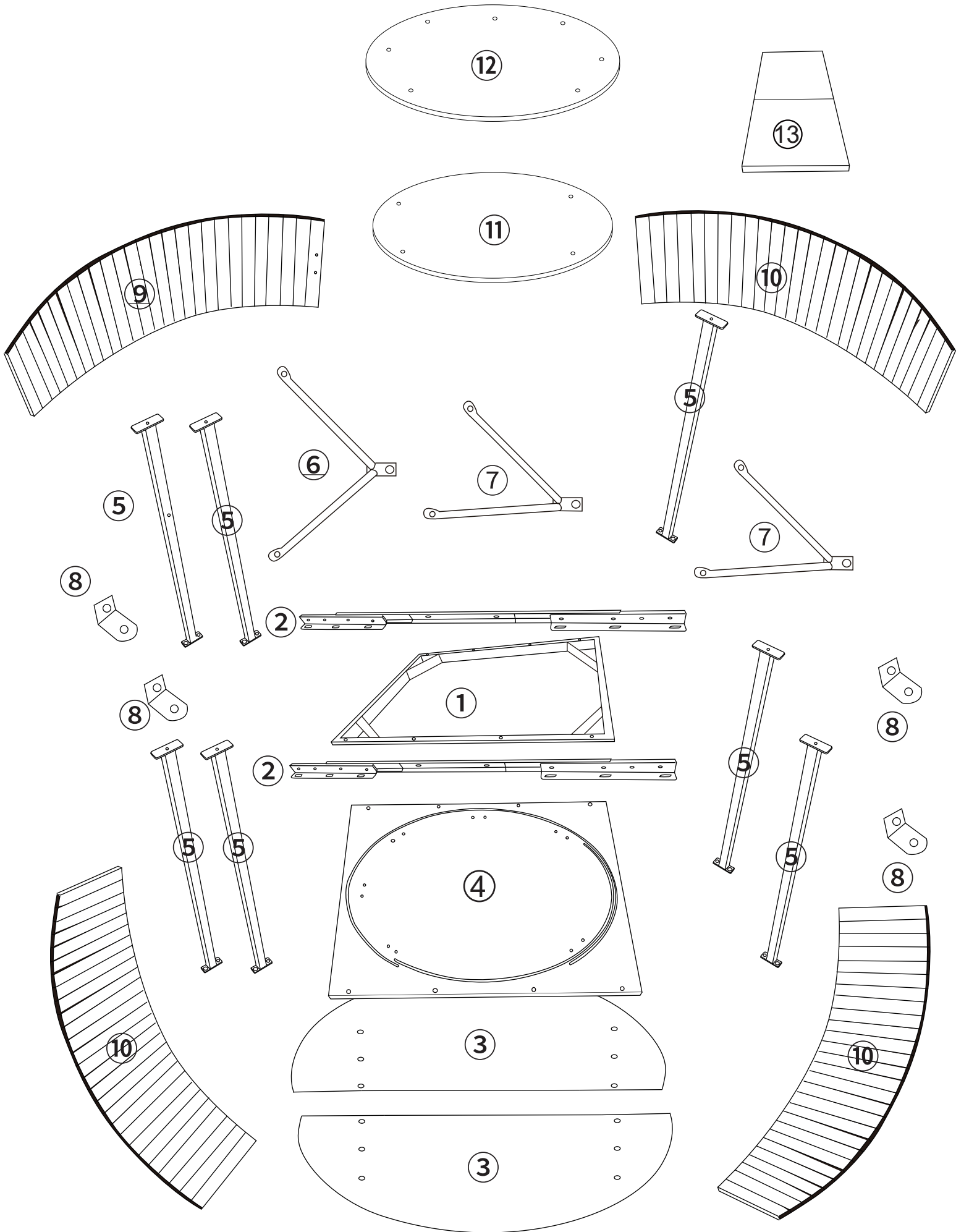

If you have any questions, please contact customer service email:

AfterSales9527@outlook.com

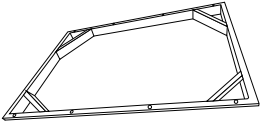

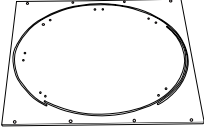
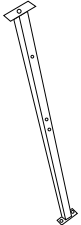
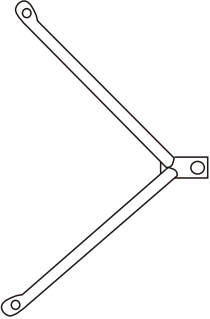
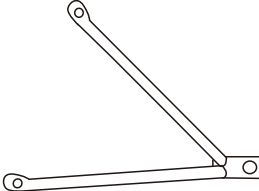

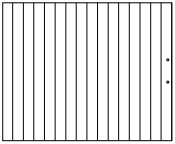
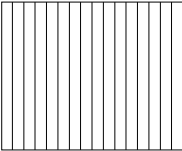

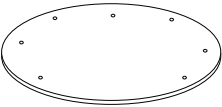
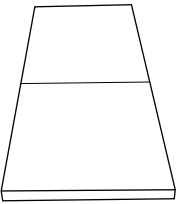

Disassembly Diagram

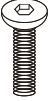

Accessories

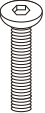
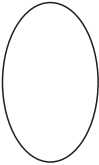
<p>①</p> <p>x1</p> 	<p>②</p> <p>x2</p> 	<p>③</p> <p>x2</p> 	<p>④</p> <p>x1</p> 
<p>⑤</p> <p>x7</p> 	<p>⑥</p> <p>x1</p> 	<p>⑦</p> <p>x2</p> 	<p>⑧</p> <p>x4</p> 
<p>⑨</p> <p>x1</p> 	<p>⑩</p> <p>x3</p> 	<p>⑪</p> <p>x1</p> 	<p>⑫</p> <p>x1</p> 
<p>⑬</p> <p>x1</p> 			

Accessories

<p>A</p> <p>x8</p>  <p>M5x10mm</p> <p>1 Spare</p>	<p>B</p> <p>x1</p> 	<p>C</p> <p>x37</p>  <p>M6x16mm</p> <p>4 Spare</p>	<p>D</p> <p>x45</p>  <p>M6x16x1.5mm</p> <p>5 Spare</p>
<p>E</p> <p>x15</p>  <p>M6x35mm</p> <p>2 Spare</p>	<p>F</p> <p>x1</p>  <p>WAX</p>	<p>G</p> <p>x2</p>  <p>M4x8mm</p>	<p>H</p> <p>x4</p>  <p>M3x14mm</p>
<p>J</p> <p>x8</p>  <p>1 Spare</p>	<p>K</p> <p>x1</p> 		

Assembly Instructions

Step1

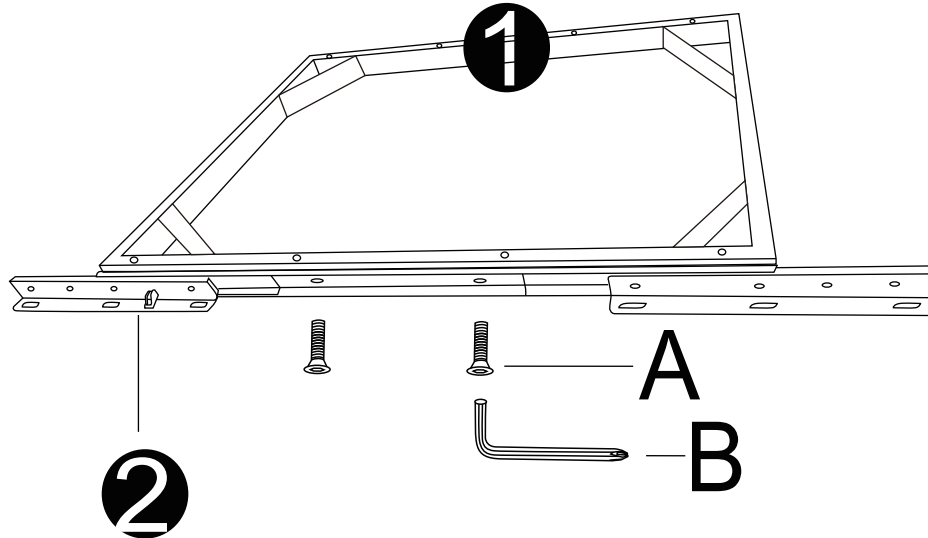
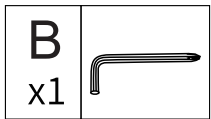
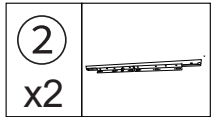
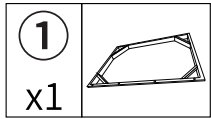

The sliding rails are assembled on both sides respectively.
Assembly screws when the slide rail is open

x2

Step2

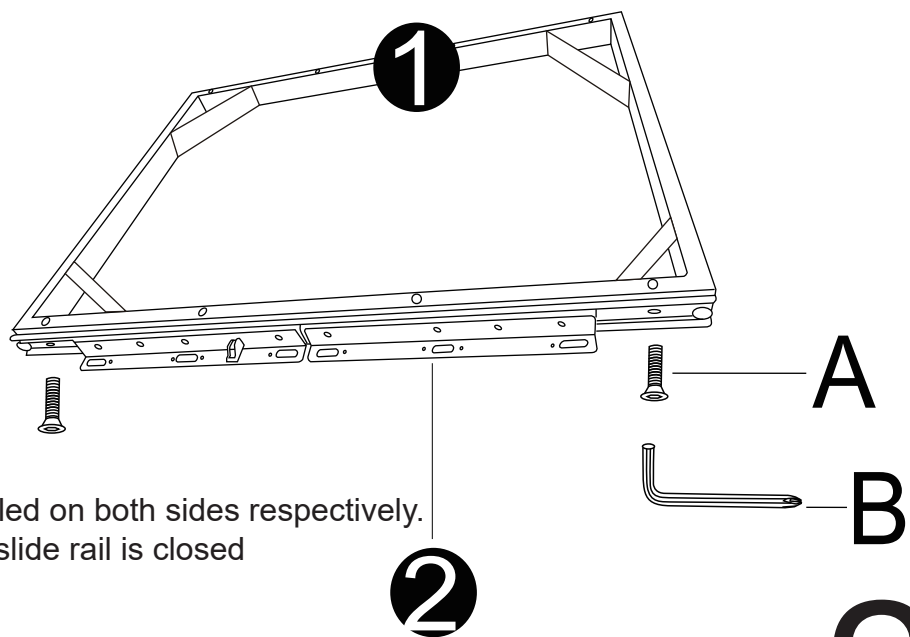
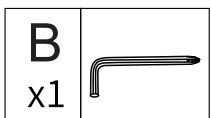
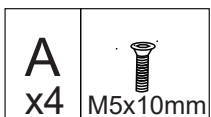
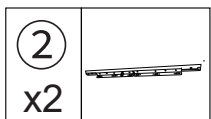
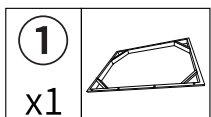



The sliding rails are assembled on both sides respectively.
Assembly screws when the slide rail is closed

x2

Assembly Instructions

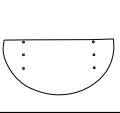
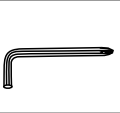

Step3

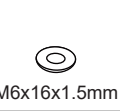
Before screwing in the screws, ensure that the center of the control slide is aligned with the gap between the panel.

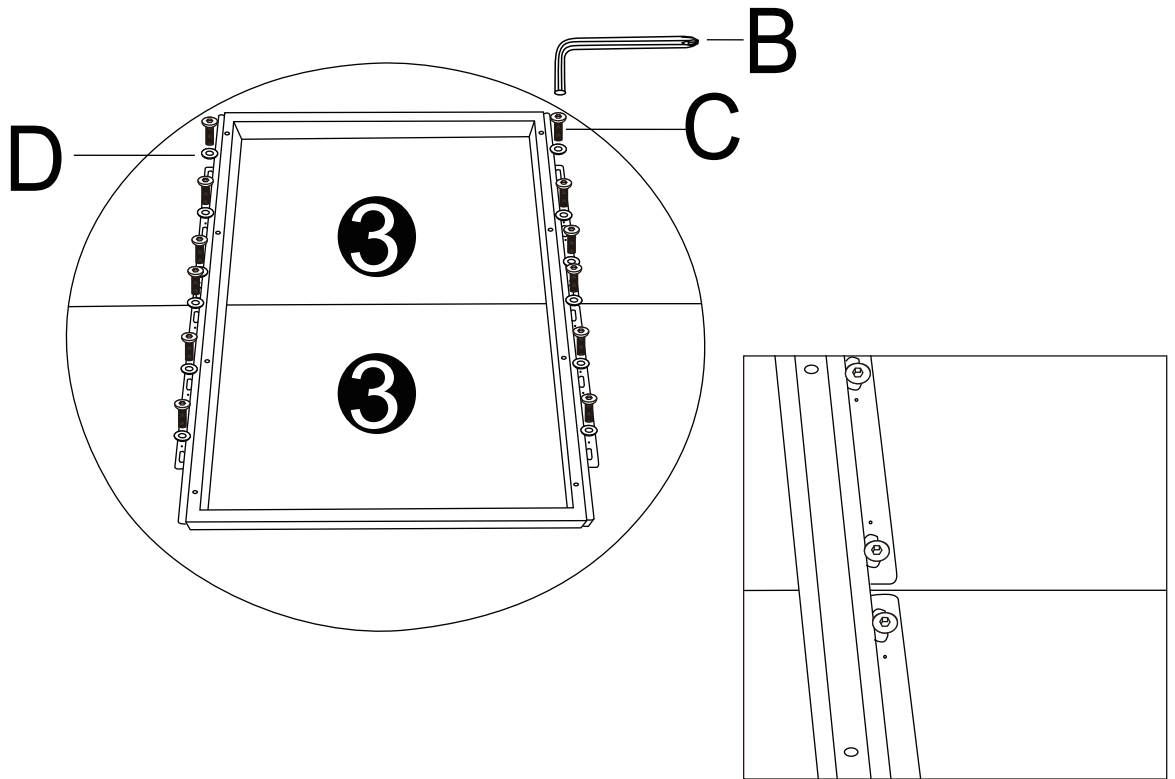
3 x2	
B x1	
C x12 M6x16mm	
D x12 M6x16x1.5mm	

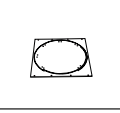
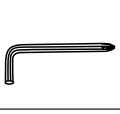
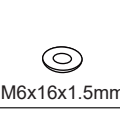

Step4

4 x1	
B x1	
D x8 M6x16x1.5mm	
E x8 M6x35mm	

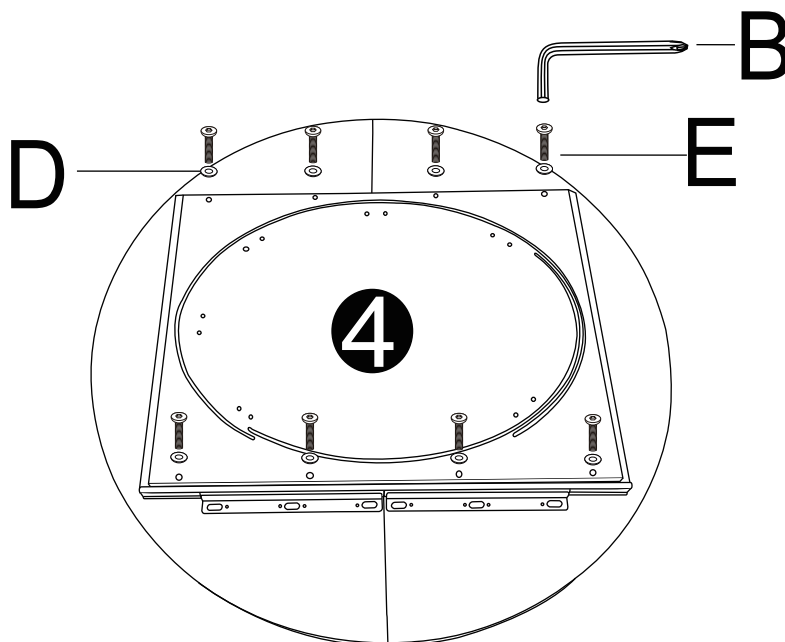

Assembly Instructions

Step 5

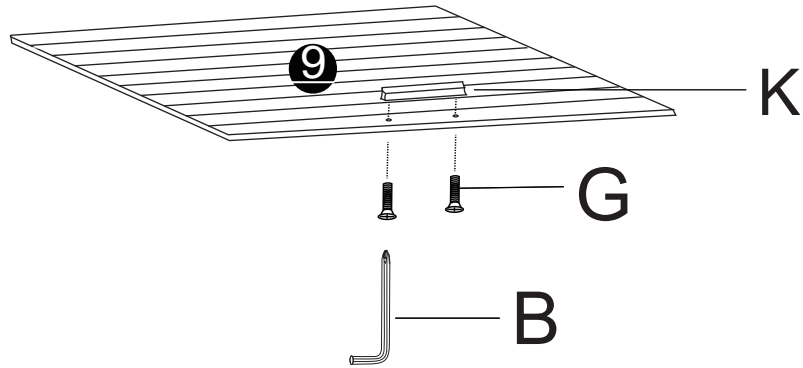
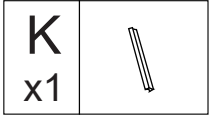
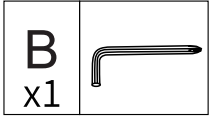
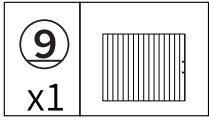

Step 6

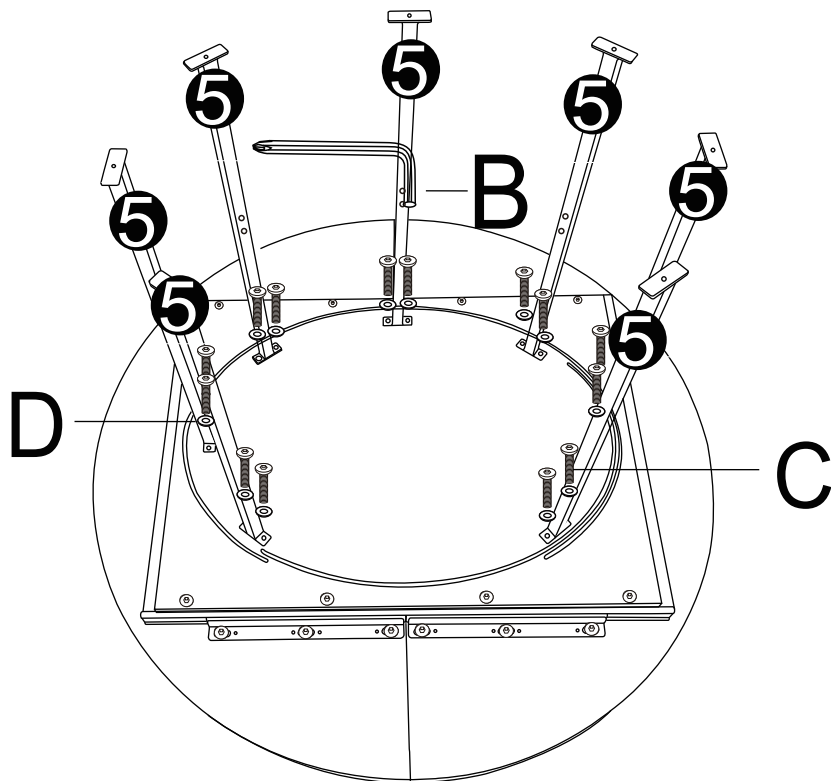
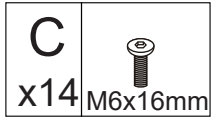
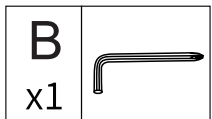
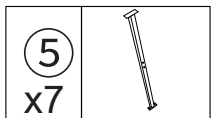

Assembly Instructions

Step 7

⑥ x1	
⑦ x2	
B x1	
C x7 M6x16mm	
D x7 M6x16x1.5mm	

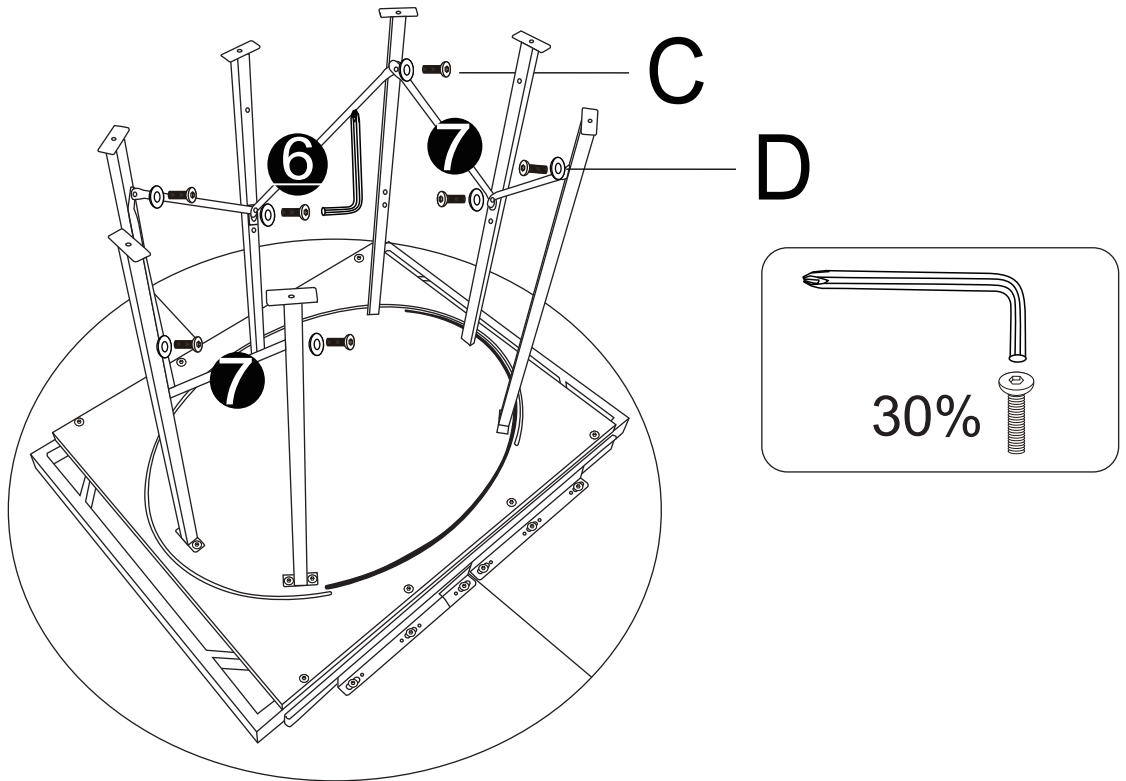

Step 8

⑧ x4	
B x1	
C x4 M6x16mm	
D x4 M6x16x1.5mm	
F x1	

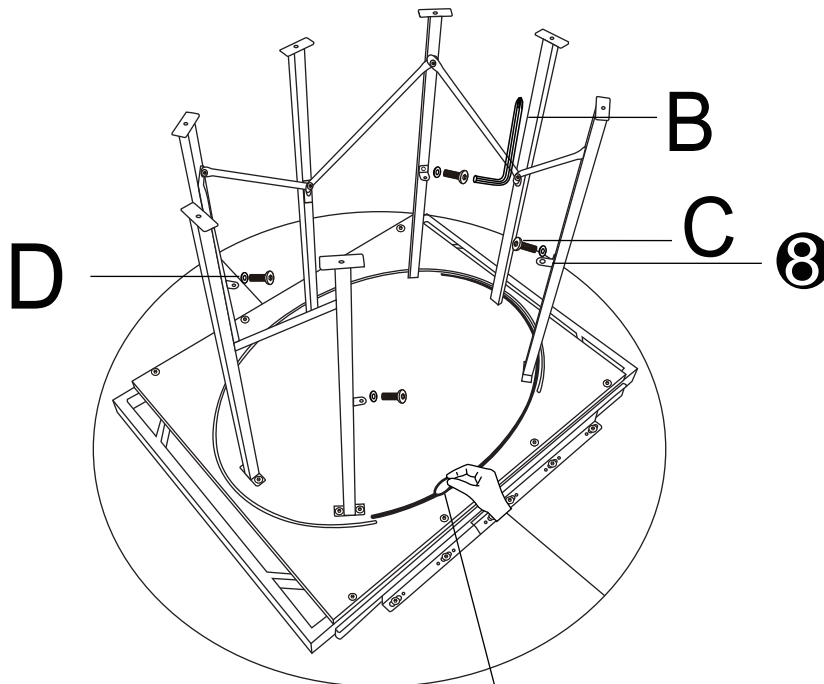

F After aligning the holes, lower it and lock it with C. Then, apply a circle of G wax blocks to the groove of the track

Assembly Instructions

Step9

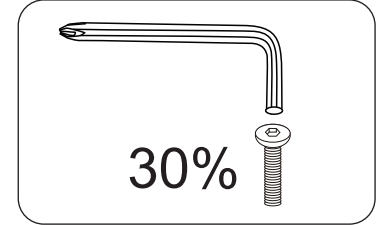
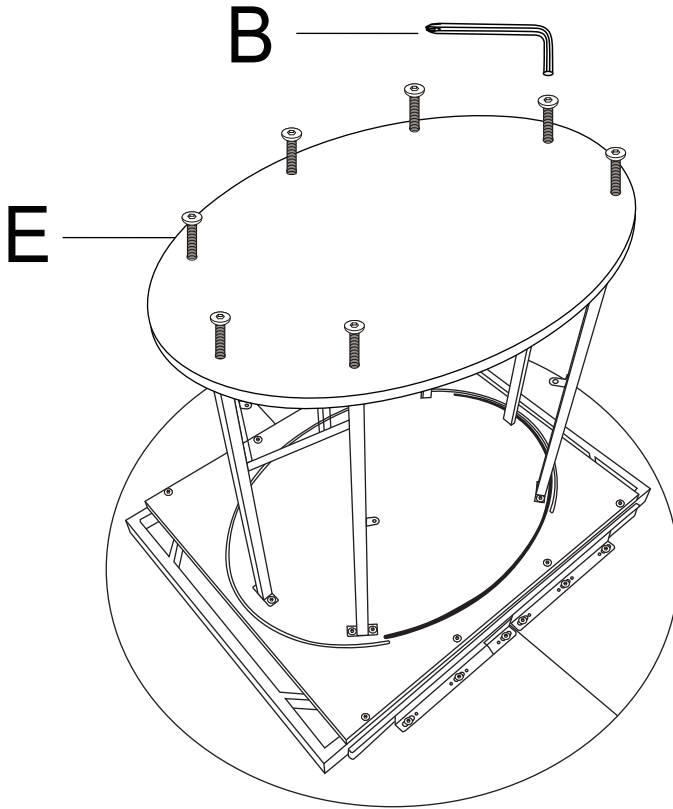
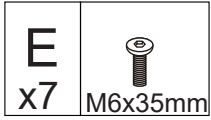
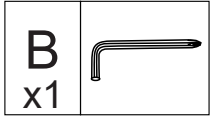

Tighten the screw only 30% and do not over-tighten.

Step10

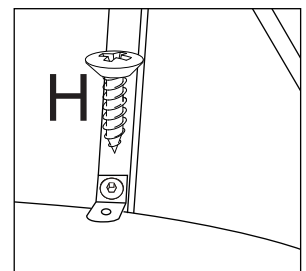
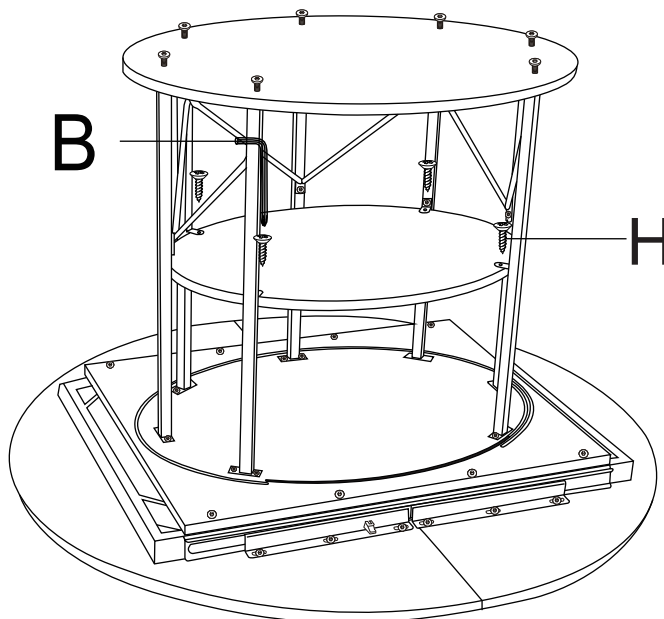
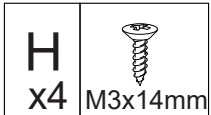
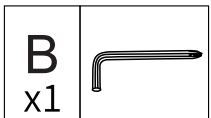
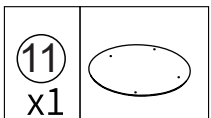

Assembly Instructions

Step11

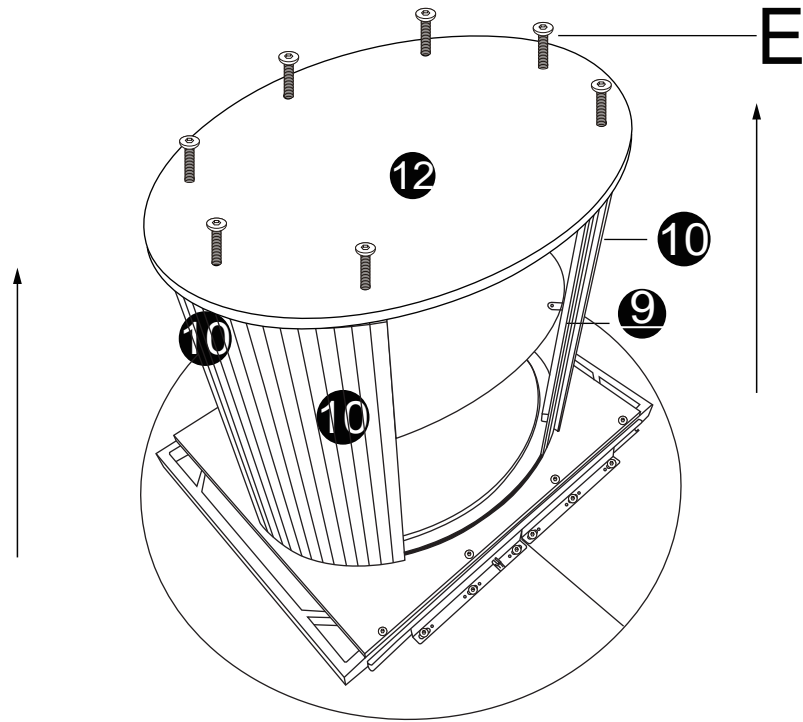
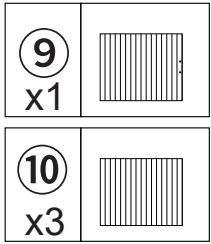

Step12

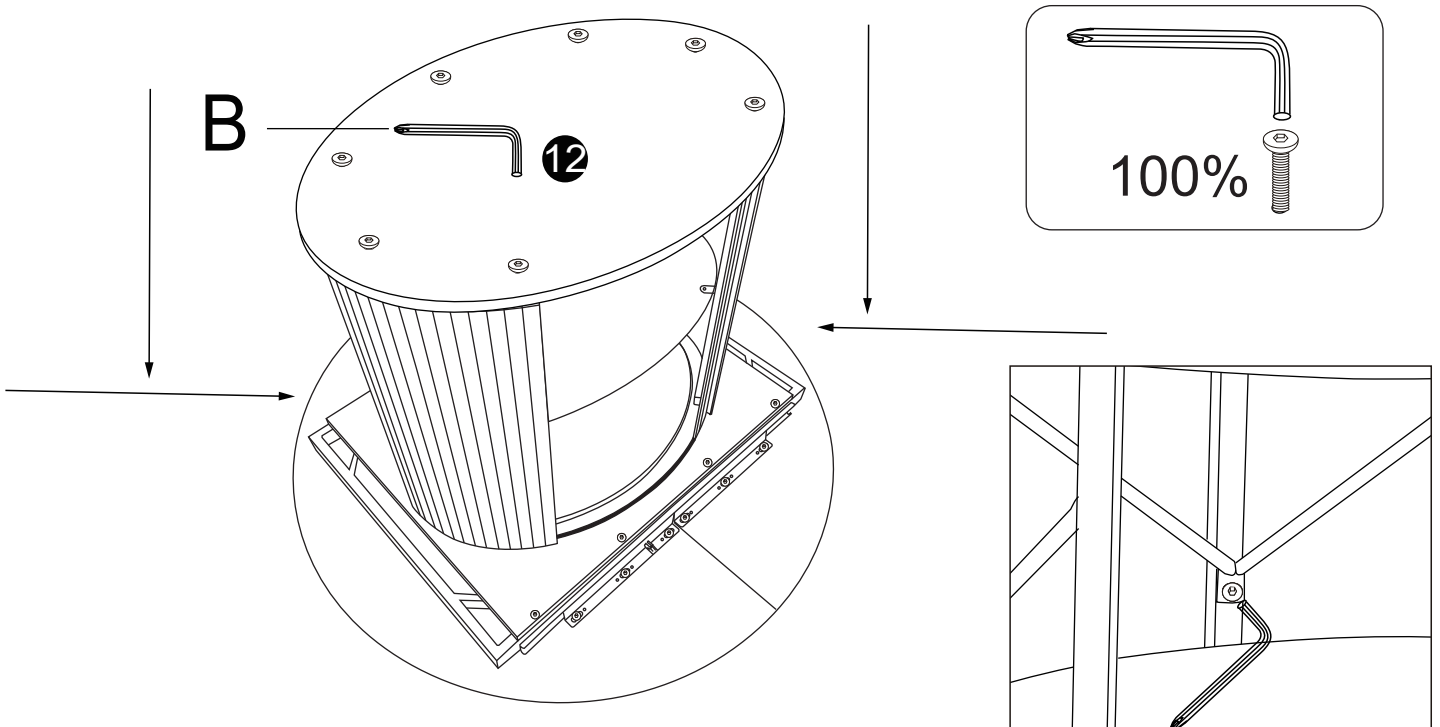

After adjusting the upright boards and inserting them into the slots, tighten the screws.

Assembly Instructions

Step13

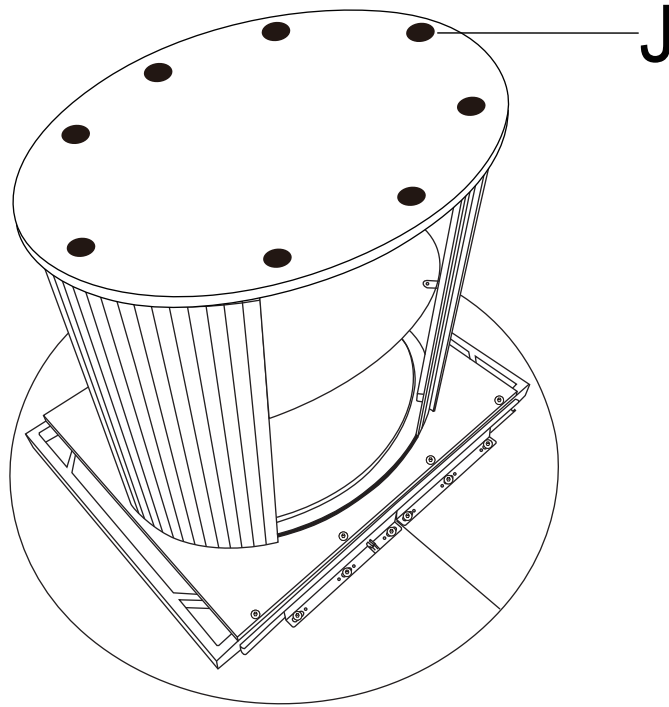
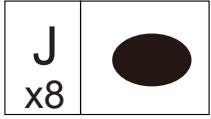

Step14

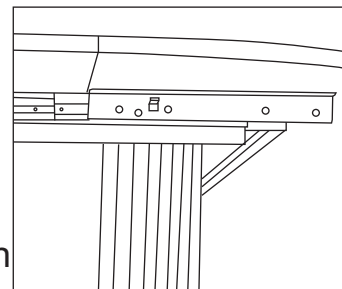
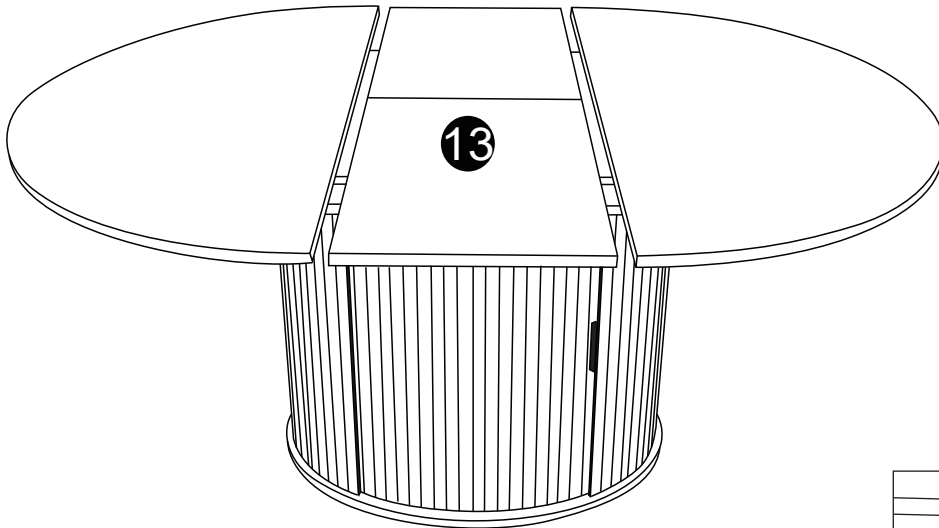
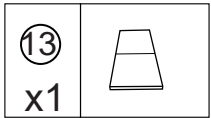

Slide rail lock, lock after pressing downward, unlock by raise the button

Assembly Instructions

Step15

The middle panel can be folded and stored

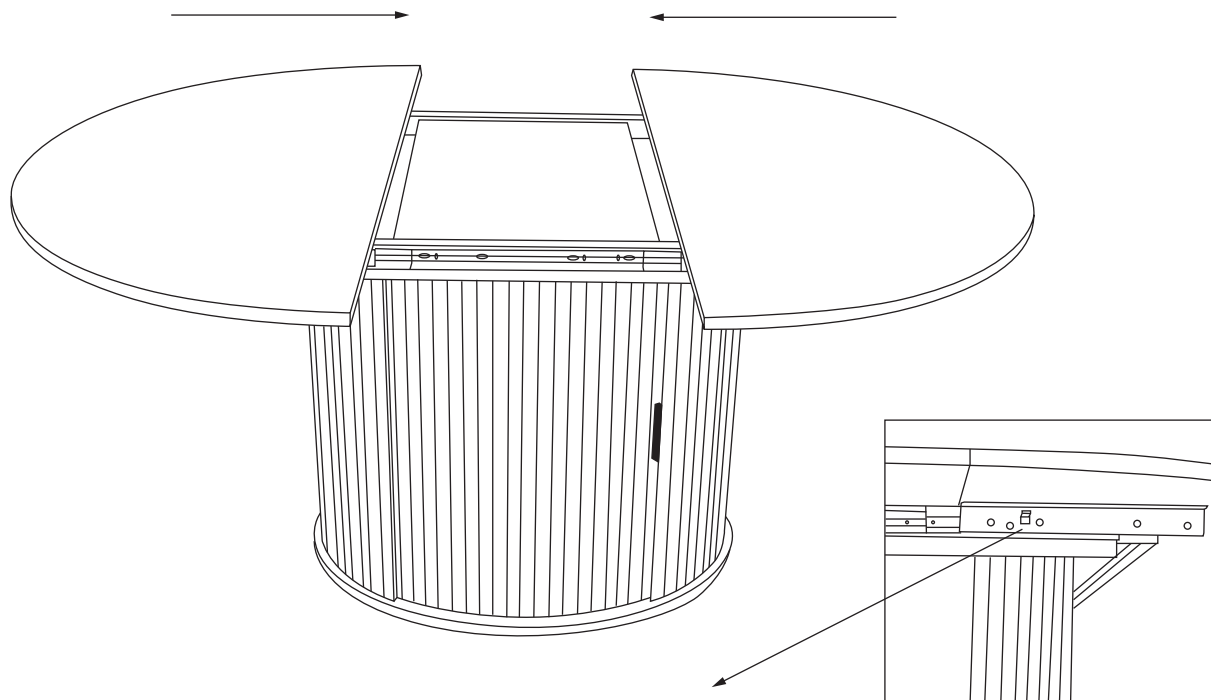

Slide rail lock, lock after pressing downward, unlock by raise the button