

# Assembly Instructions

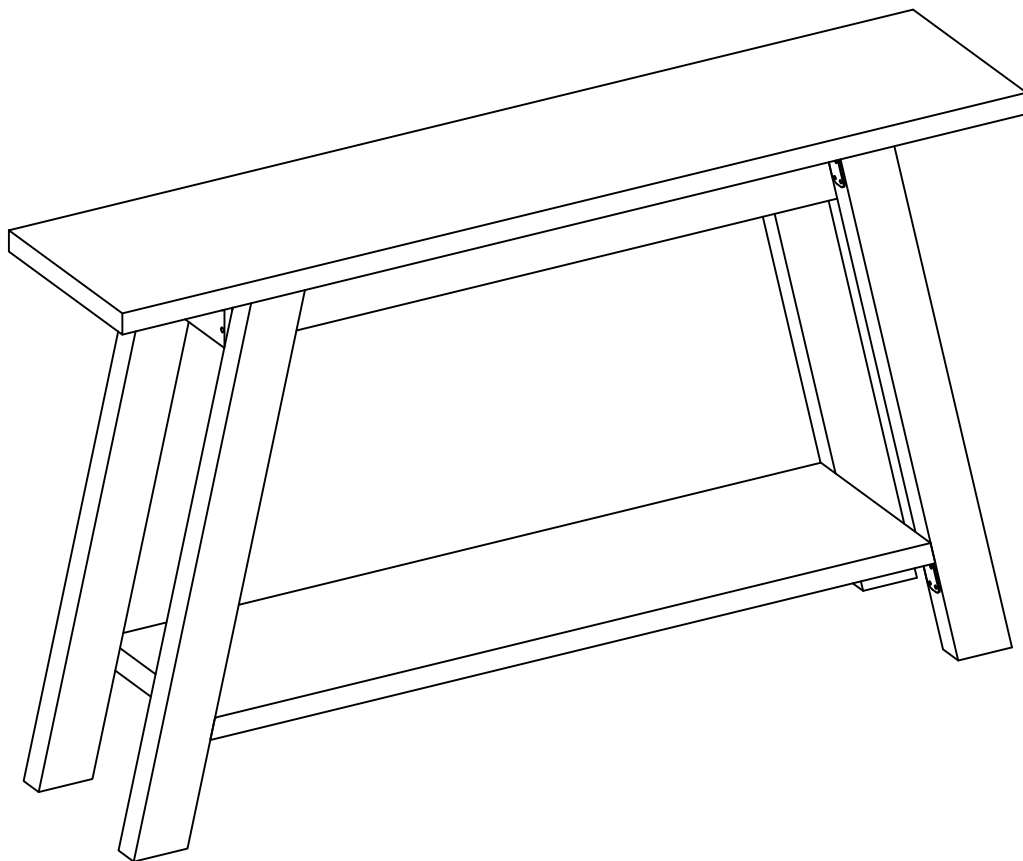

**Attention:** Please ensure you have all parts before commencing assembly.  
Please read all the instructions before commencing.

PART LIST

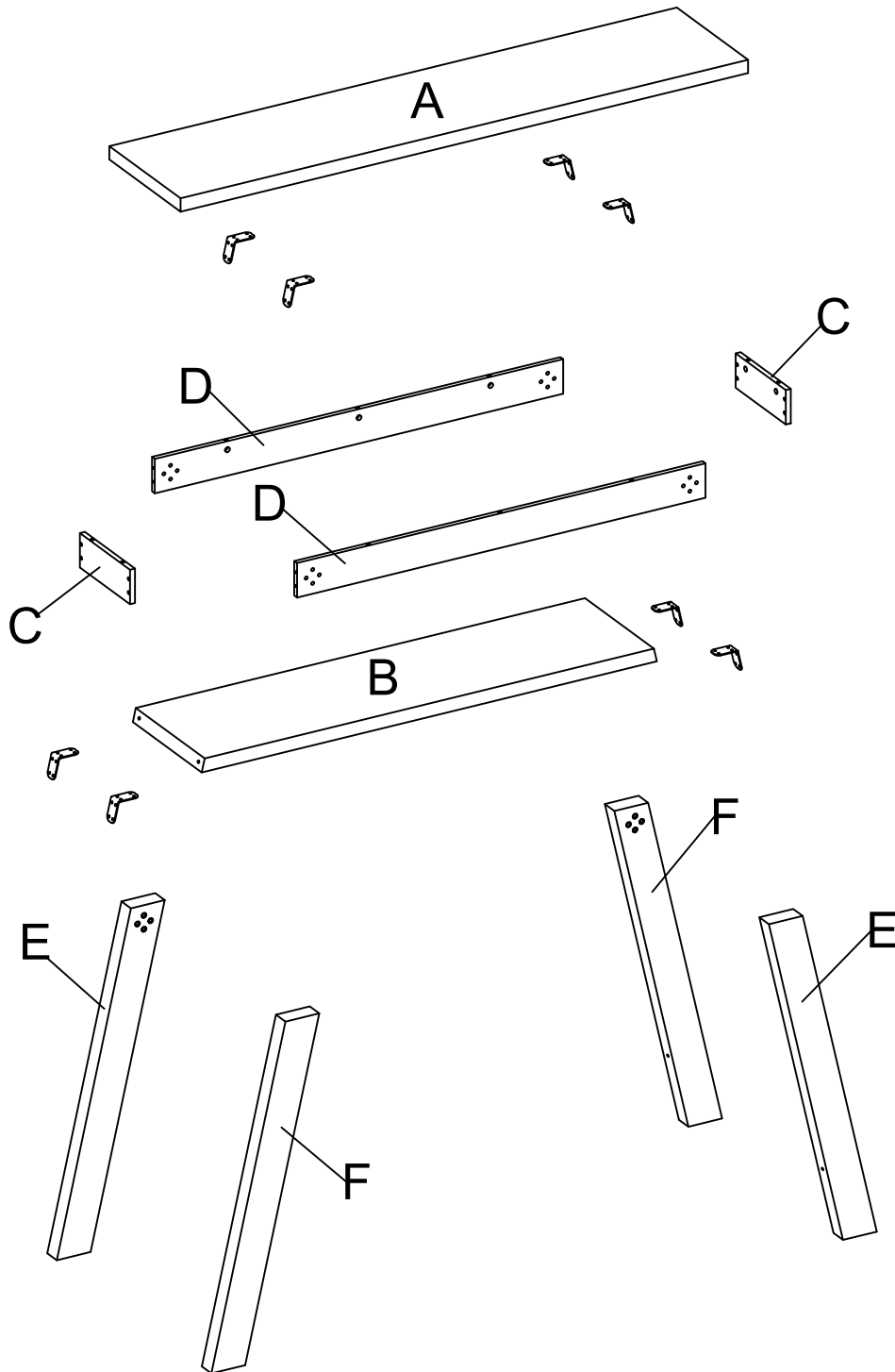

PART LIST

A x 1pc

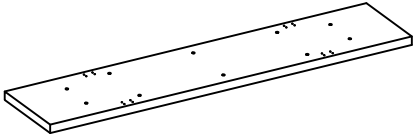

B x 1pc

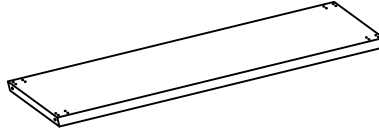

C x 2pcs

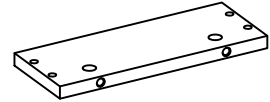

D x 2pcs

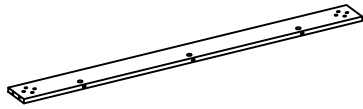



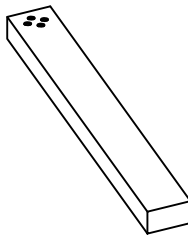

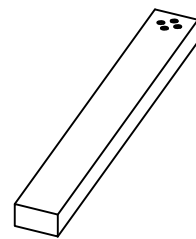

E x 2pcs

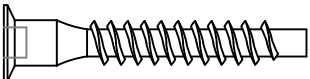
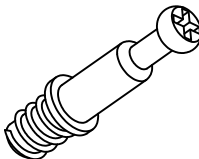

F x 2pcs

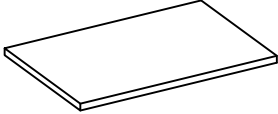
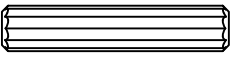
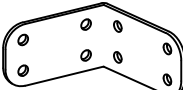
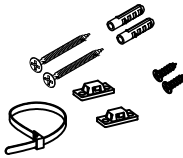
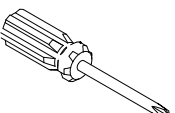

## HARDWARE LIST

<p>①</p>  <p>M6x40</p> <p style="text-align: right;">8 pcs</p>	<p>②</p>  <p>M6x28</p> <p style="text-align: right;">10 pcs</p>	<p>③</p>  <p>Ø12</p> <p style="text-align: right;">10 pcs</p>
<p>④</p>  <p>M6x20</p> <p style="text-align: right;">16 pcs</p>	<p>⑤</p>  <p>M4x12</p> <p style="text-align: right;">64 pcs</p>	<p>⑥</p>  <p>20*30</p> <p style="text-align: right;">4 pcs</p>
<p>⑦</p>  <p>M6x30</p> <p style="text-align: right;">4 pcs</p>	<p>⑧</p>  <p style="text-align: right;">8 pcs</p>	<p>⑨</p>  <p>M4x40*2 M4x14*2</p> <p style="text-align: right;">1 pc</p>
<p>⑩</p>  <p style="text-align: right;">1 pc</p>	<p>⑪</p>  <p>M4</p> <p style="text-align: right;">1 pc</p>	

\*Please count and verify all parts before assembly.\*

# How to install Camlocks

Connect the male camlock as directed in the assembly instructions with a screwdriver.

**1** DO NOT OVER TIGHTEN

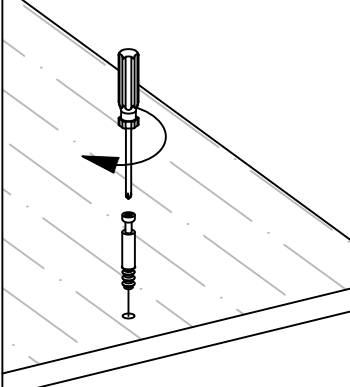

Put the male camlock into the entry hole.

**2**

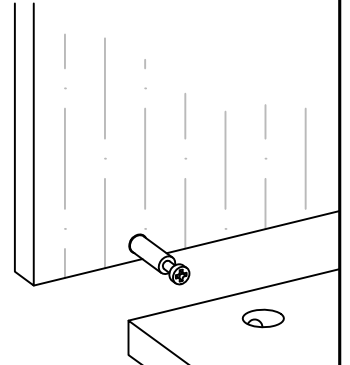

Insert the female camlock as shown in the instruction.

Note: ensure that the arrow on the top of the camlock points toward the entry hole for the male camlock.

**3**

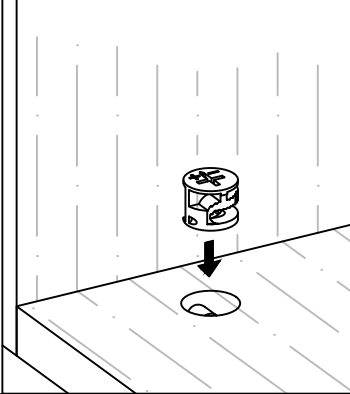

Screw the female camlock clockwise with a screwdriver.

You will feel a click when the camlock is locked in place.

The camlock is now completed.

**4**

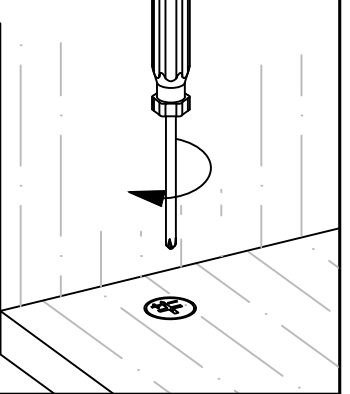

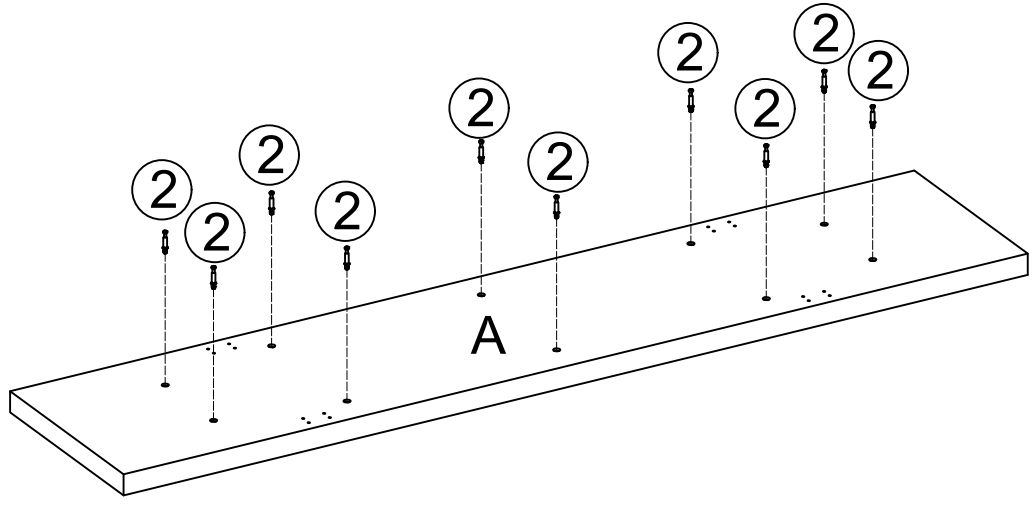

# STEP 1

2  x10



# STEP 2

5  x16  
8  x4

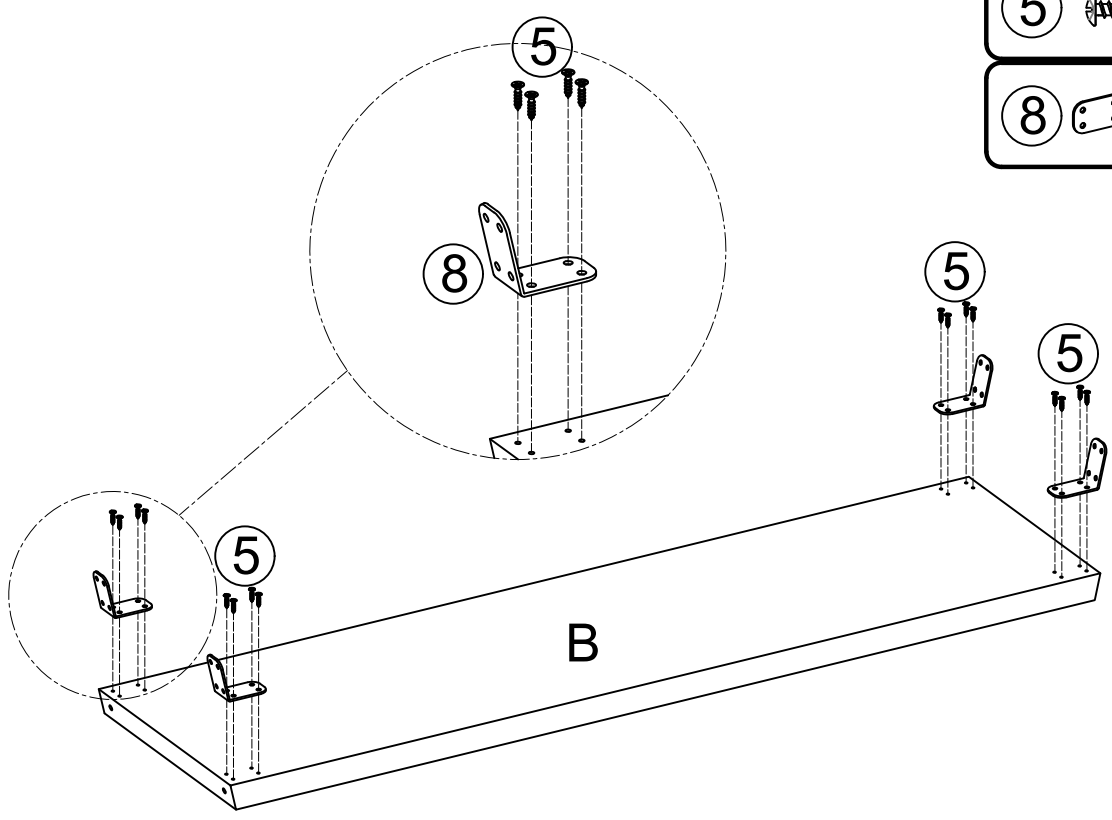

### STEP 3

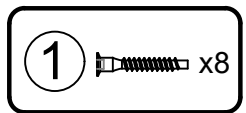

Keep the holes of the Part D and Part C toward this direction as shown

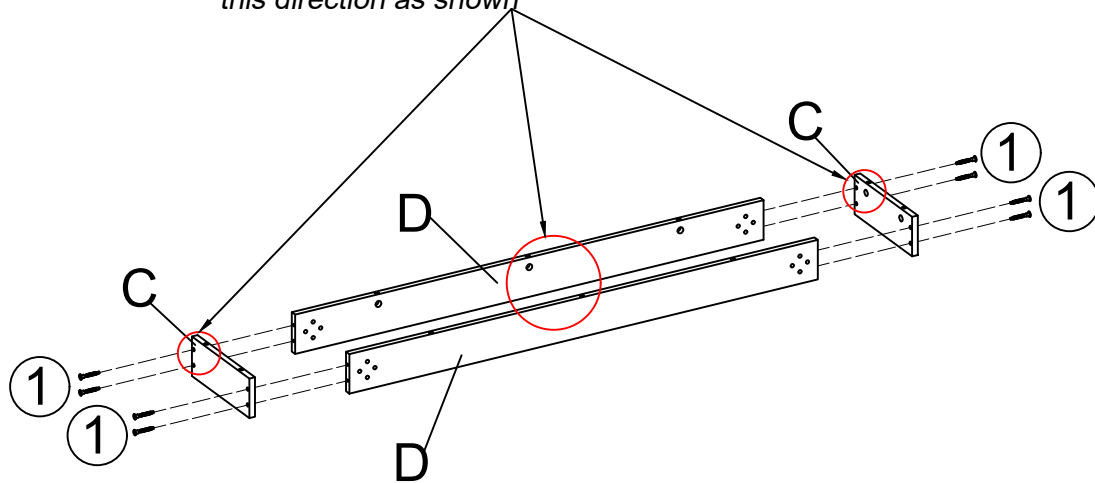

### STEP 4

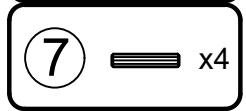
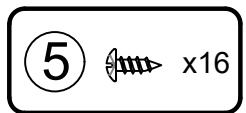

Note: Before tightening the screws, push the wood boards tightly to make closer, otherwise it may cause large gaps.

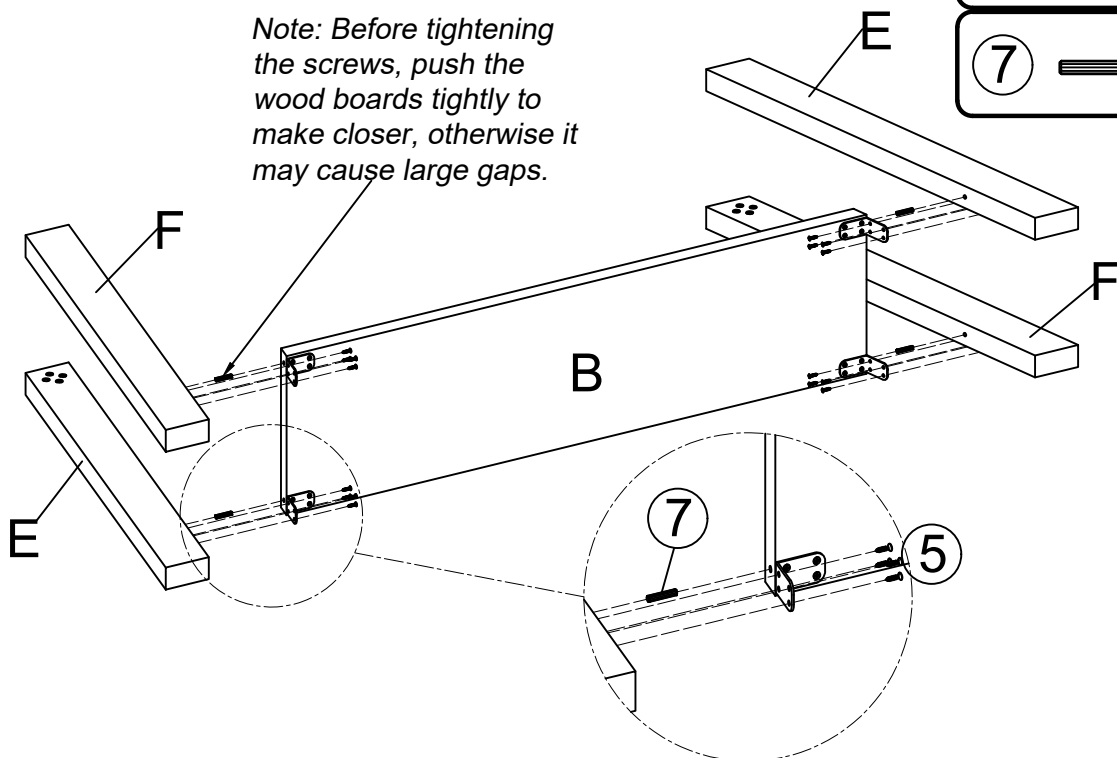

### STEP 5

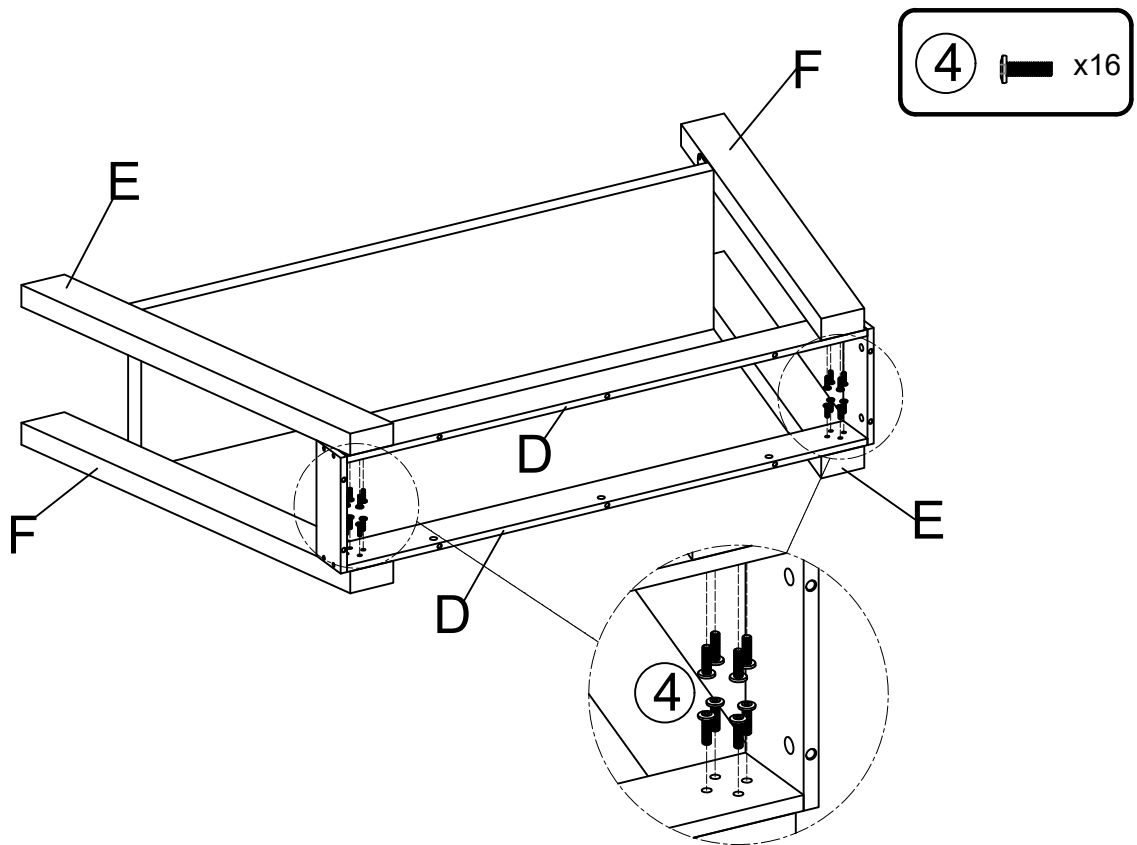

### STEP 6

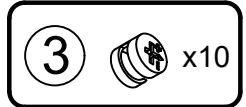
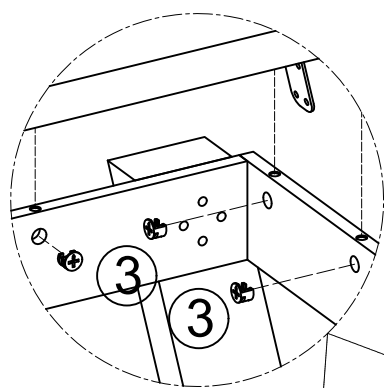

*Note: Before tightening the screws, push the wood boards tightly to make closer, otherwise it may cause large gaps.*

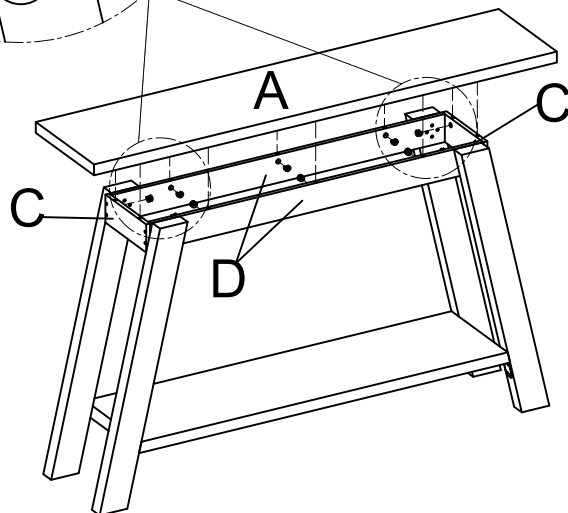

## STEP 7

NOTE: After the panel is installed, align the reserved holes on the top and tighten the screws.

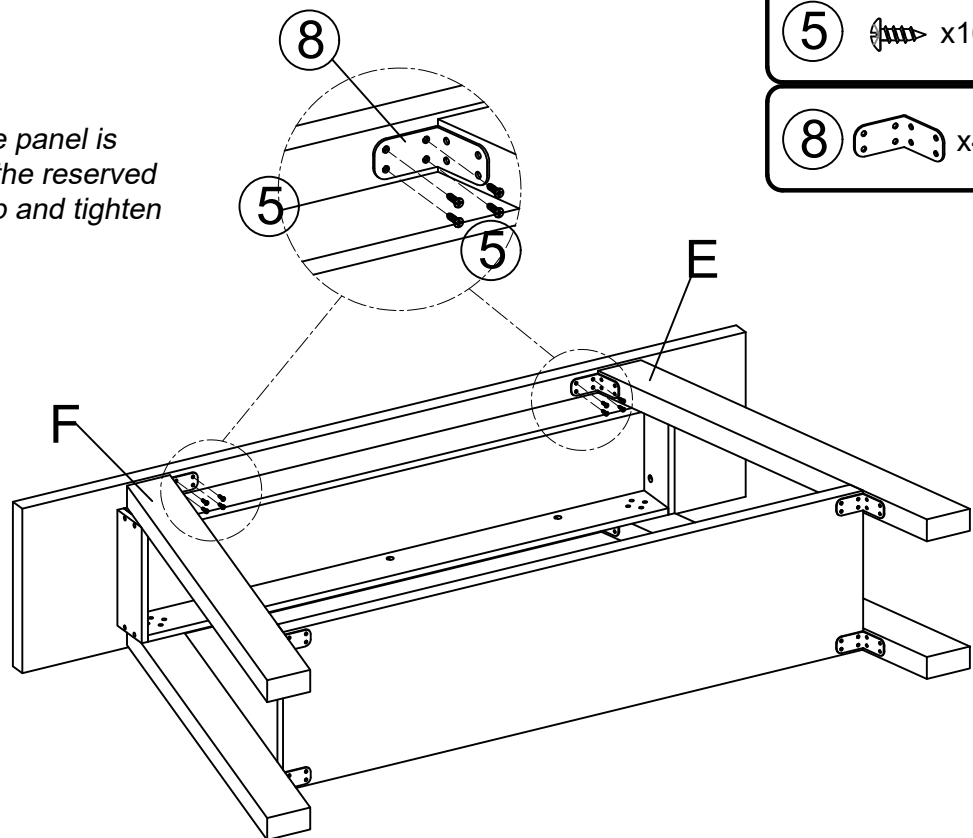

## STEP 8

NOTE: There are no reserved holes on the table legs (panel E and F). After fixing the top screws, tighten the screws directly at the actual position where the angle code corresponds to the table legs.

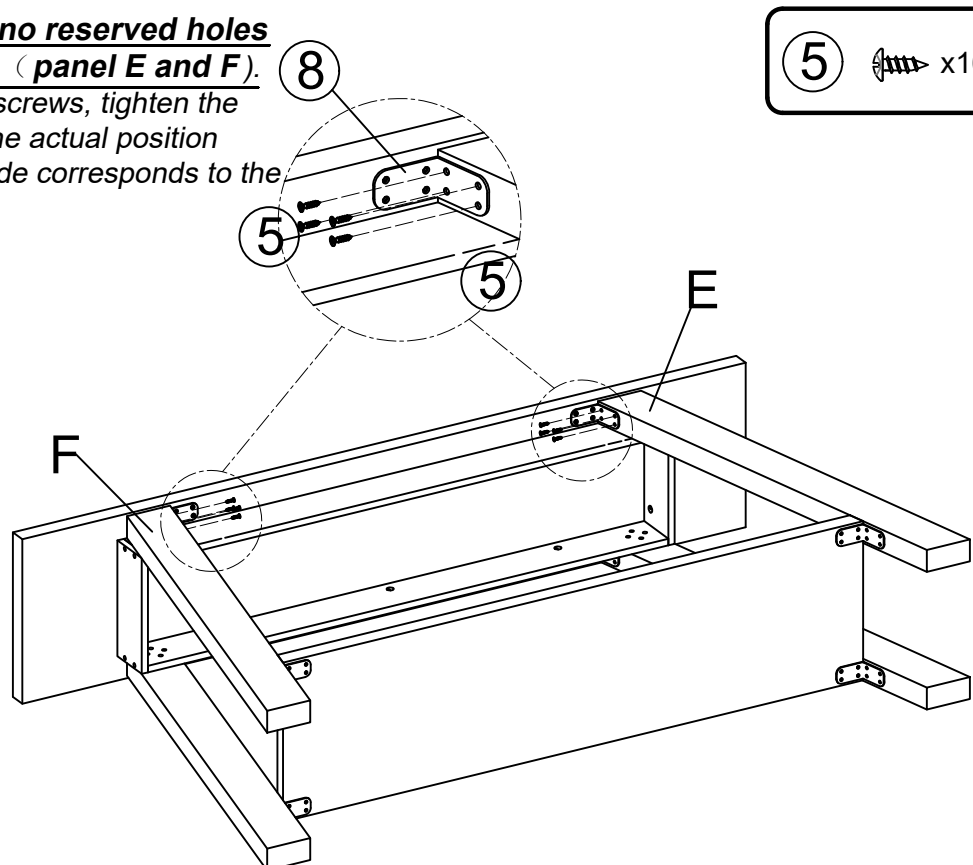

**STEP 9**

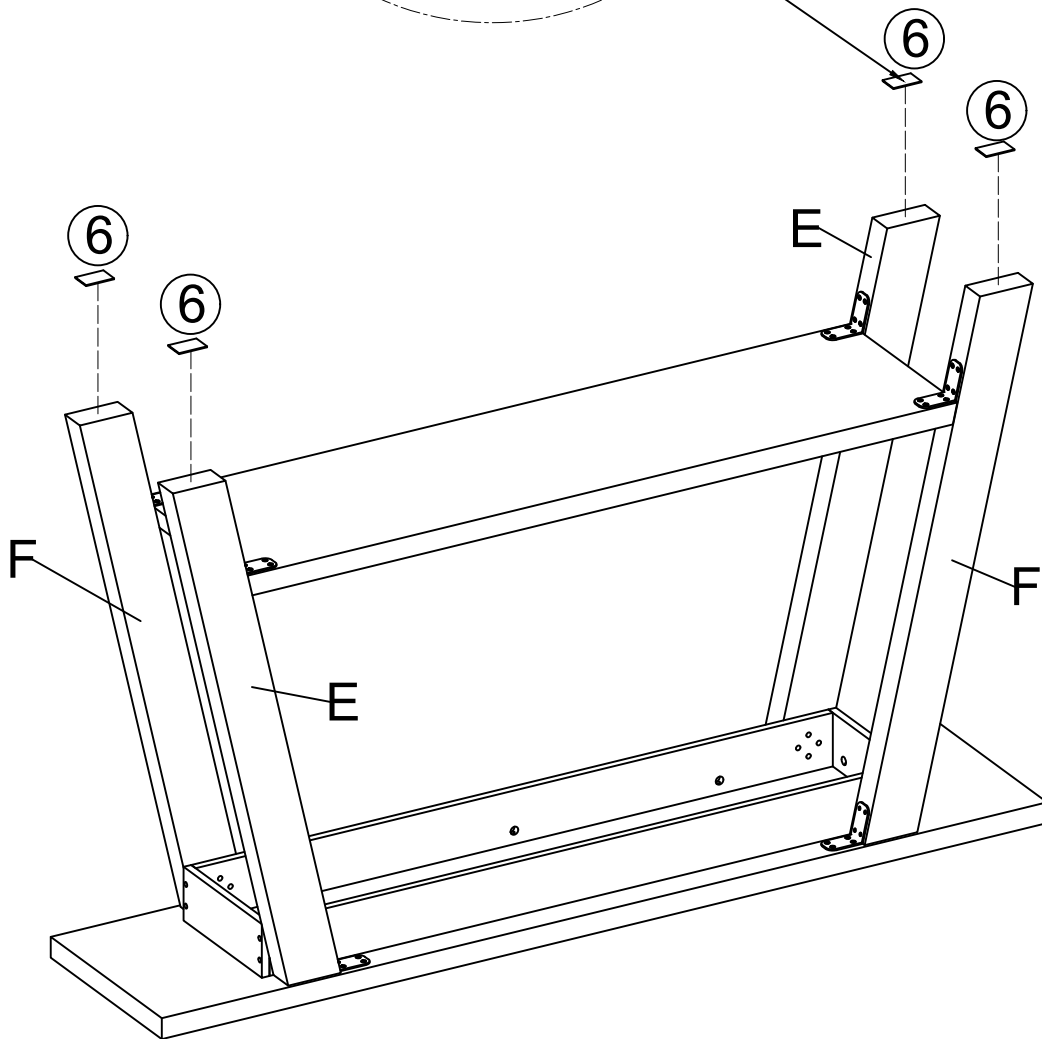
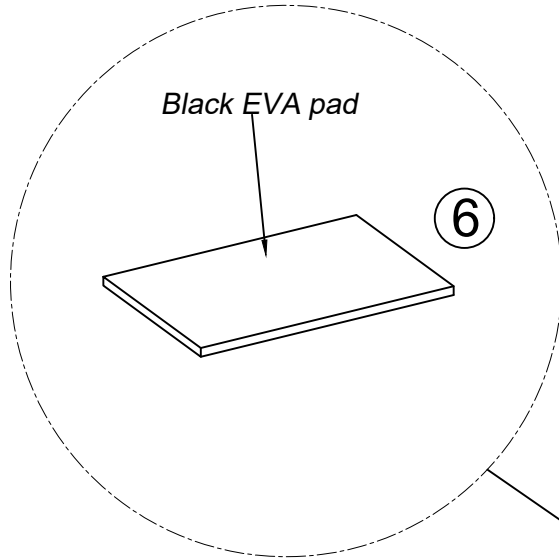
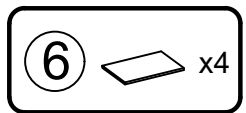

## STEP 11

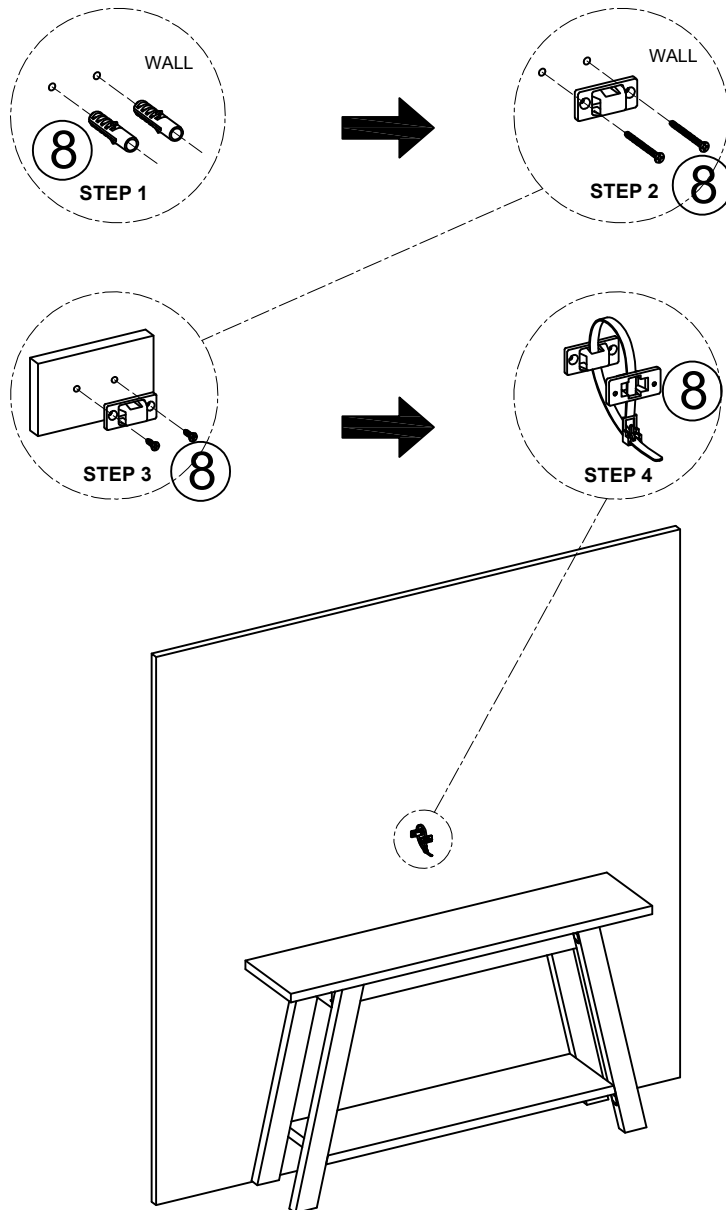
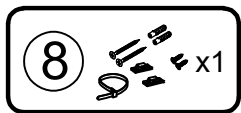

### **Installation Steps:**

1. Drill a hole on the wall, insert the expansion bolt into the hole.

**Installation Steps:**

2. Secure one bracket into the expansion bolt using the screw.

3. Position the furniture in place. Attach another bracket (aligns with the bracket on the wall) to the back edge of unit top using the screw

4. Thread the male end of the steel cable through both brackets. Securely join the ends by turning the female connector clockwise.

### **Note:**

Before installing the anti-tip kit, please determine where the furniture is to be placed and locate the center line of a wooden stud using a stud finder.

For a concrete wall, ensure no steel b

(Anti-tipping accessories are not mandatory. You can consider whether to install them according to your home decoration )