

Assembly Instructions

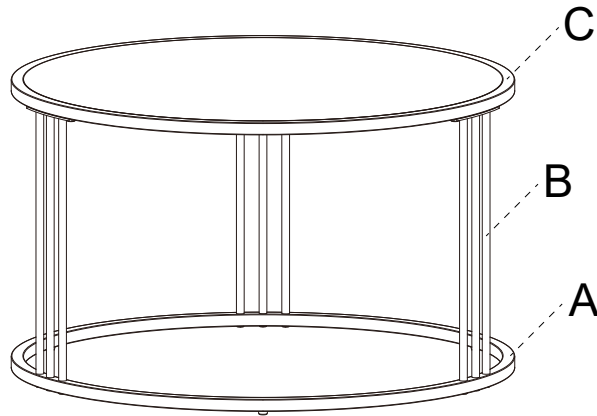

Assemble on the pad to prevent scratching the product.
Do not tighten all screws before instructions prompt.



Parts List

Open the hardware check all parts QTY, thanks

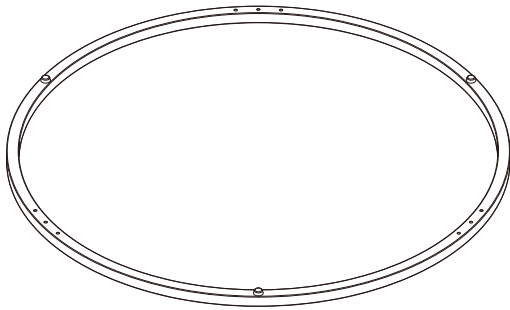

A x 1
(Bottom frame)

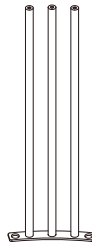

B x 3
(Mid frame)

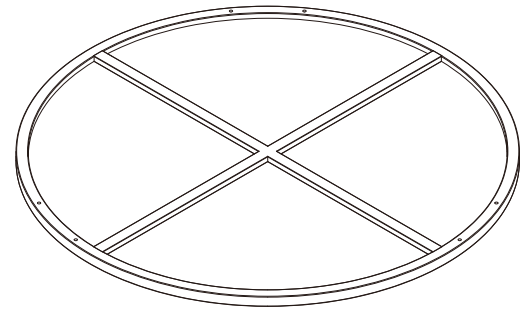

C x 1
(Top frame)



D x 15
(Short screws)

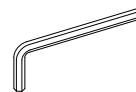

E x 1
(Wrench, tighten clockwise)

Step 1

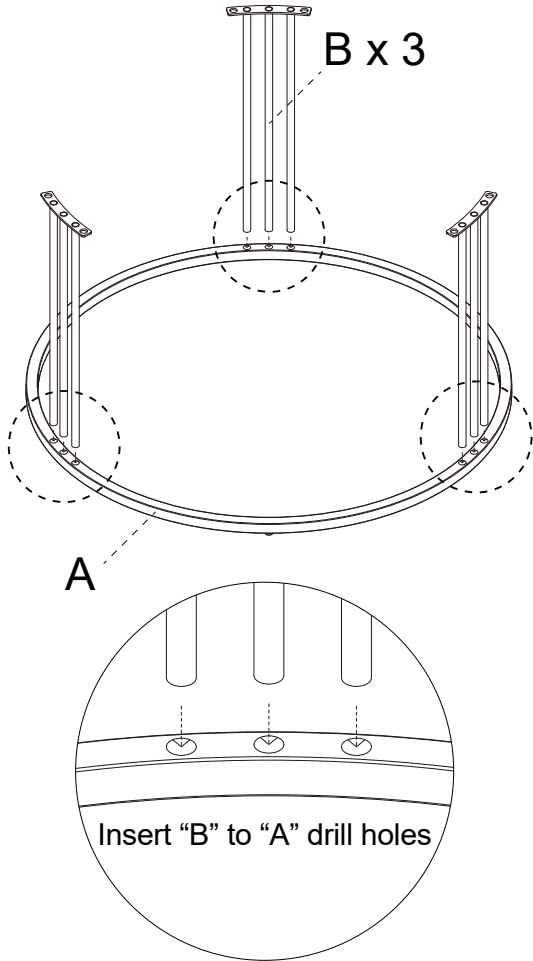

Step 2

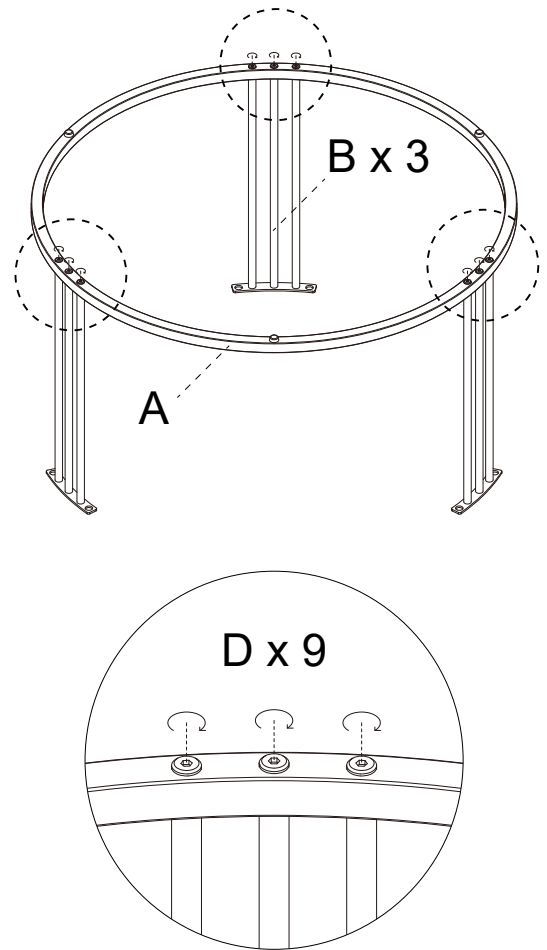

Step 3

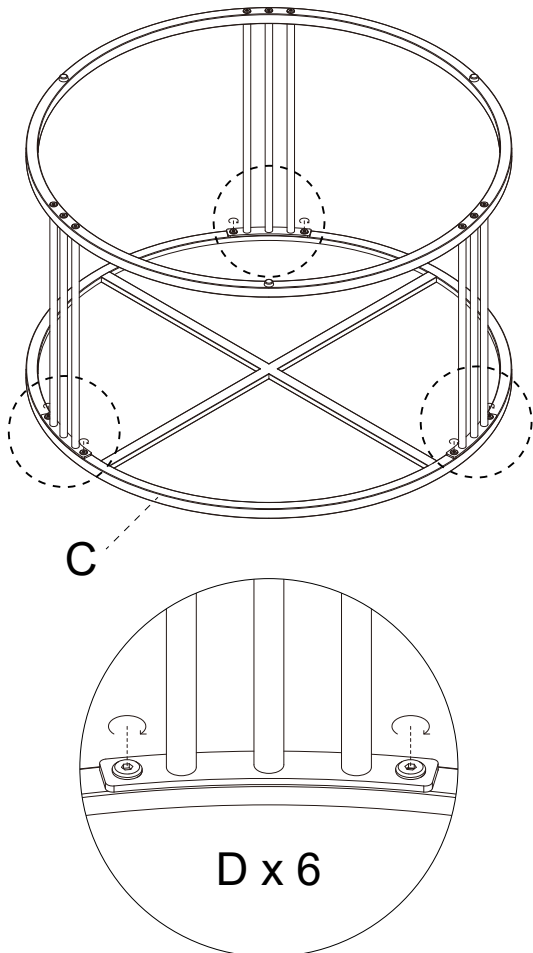

Step 4

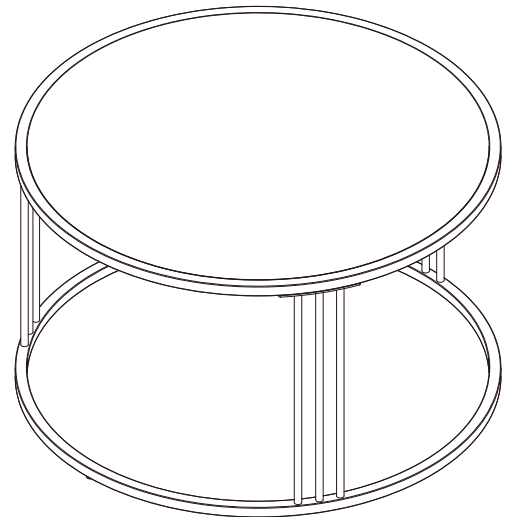

Tighten all screws and turn it over to finish.